

COMPREHENSIVE SERVICES

We offer competitive repair and calibration services, as well as easily accessible documentation and free downloadable resources.

SELL YOUR SURPLUS

We buy new, used, decommissioned, and surplus parts from every NI series. We work out the best solution to suit your individual needs.

 Sell For Cash  Get Credit  Receive a Trade-In Deal

OBSOLETE NI HARDWARE IN STOCK & READY TO SHIP

We stock **New**, **New Surplus**, **Refurbished**, and **Reconditioned** NI Hardware.



Bridging the gap between the manufacturer and your legacy test system.

 1-800-915-6216

 www.apexwaves.com

 sales@apexwaves.com

All trademarks, brands, and brand names are the property of their respective owners.

Request a Quote

 **CLICK HERE**

PXIe-8820

PXI Express

NI PXIe-8820 User Manual

Worldwide Technical Support and Product Information

ni.com

Worldwide Offices

Visit ni.com/niglobal to access the branch office Web sites, which provide up-to-date contact information, support phone numbers, email addresses, and current events.

National Instruments Corporate Headquarters

11500 North Mopac Expressway Austin, Texas 78759-3504 USA Tel: 512 683 0100

For further support information, refer to the *Technical Support and Professional Services* appendix. To comment on National Instruments documentation, refer to the National Instruments Web site at ni.com/info and enter the Info Code `feedback`.

Important Information

Warranty

The NI PXIe-8220 is warranted against defects in materials and workmanship for a period of one year from the date of shipment, as evidenced by receipts or other documentation. National Instruments will, at its option, repair or replace equipment that proves to be defective during the warranty period. This warranty includes parts and labor.

The media on which you receive National Instruments software are warranted not to fail to execute programming instructions, due to defects in materials and workmanship, for a period of 90 days from date of shipment, as evidenced by receipts or other documentation. National Instruments will, at its option, repair or replace software media that do not execute programming instructions if National Instruments receives notice of such defects during the warranty period. National Instruments does not warrant that the operation of the software shall be uninterrupted or error free.

A Return Material Authorization (RMA) number must be obtained from the factory and clearly marked on the outside of the package before any equipment will be accepted for warranty work. National Instruments will pay the shipping costs of returning to the owner parts which are covered by warranty.

National Instruments believes that the information in this document is accurate. The document has been carefully reviewed for technical accuracy. In the event that technical or typographical errors exist, National Instruments reserves the right to make changes to subsequent editions of this document without prior notice to holders of this edition. The reader should consult National Instruments if errors are suspected. In no event shall National Instruments be liable for any damages arising out of or related to this document or the information contained in it.

EXCEPT AS SPECIFIED HEREIN, NATIONAL INSTRUMENTS MAKES NO WARRANTIES, EXPRESS OR IMPLIED, AND SPECIFICALLY DISCLAIMS ANY WARRANTY OF MERCHANTABILITY OR FITNESS FOR A PARTICULAR PURPOSE. CUSTOMER'S RIGHT TO RECOVER DAMAGES CAUSED BY FAULT OR NEGLIGENCE ON THE PART OF NATIONAL INSTRUMENTS SHALL BE LIMITED TO THE AMOUNT THEREOF PAID BY THE CUSTOMER. NATIONAL INSTRUMENTS WILL NOT BE LIABLE FOR DAMAGES RESULTING FROM LOSS OF DATA, PROFITS, USE OF PRODUCTS, OR INCIDENTAL OR CONSEQUENTIAL DAMAGES, EVEN IF ADVISED OF THE POSSIBILITY THEREOF. This limitation of the liability of National Instruments will apply regardless of the form of action, whether in contract or tort, including negligence. Any action against National Instruments must be brought within one year after the cause of action accrues. National Instruments shall not be liable for any delay in performance due to causes beyond its reasonable control. The warranty provided herein does not cover damages, defects, malfunctions, or service failures caused by owner's failure to follow the National Instruments installation, operation, or maintenance instructions; owner's modification of the product; owner's abuse, misuse, or negligent acts; and power failure or surges, fire, flood, accident, actions of third parties, or other events outside reasonable control.

Copyright

Under the copyright laws, this publication may not be reproduced or transmitted in any form, electronic or mechanical, including photocopying, recording, storing in an information retrieval system, or translating, in whole or in part, without the prior written consent of National Instruments Corporation.

National Instruments respects the intellectual property of others, and we ask our users to do the same. NI software is protected by copyright and other intellectual property laws. Where NI software may be used to reproduce software or other materials belonging to others, you may use NI software only to reproduce materials that you may reproduce in accordance with the terms of any applicable license or other legal restriction.

End-User License Agreements and Third-Party Legal Notices

You can find end-user license agreements (EULAs) and third-party legal notices in the following locations:

- Notices are located in the <National Instruments>_Legal Information and <National Instruments> directories.
- EULAs are located in the <National Instruments>\Shared\MDF\Legal\license directory.
- Review <National Instruments>_Legal Information.txt for more information on including legal information in installers built with NI products.

Trademarks

Refer to the *NI Trademarks and Logo Guidelines* at ni.com/trademarks for more information on National Instruments trademarks.

ARM, Keil, and μ Vision are trademarks or registered of ARM Ltd or its subsidiaries.

LEGO, the LEGO logo, WEDO, and MINDSTORMS are trademarks of the LEGO Group. ©2013 The LEGO Group.

TETRIX by Pitsco is a trademark of Pitsco, Inc.©2013

FIELDBUS FOUNDATION™ and FOUNDATION™ are trademarks of the Fieldbus Foundation.

EtherCAT® is a registered trademark of and licensed by Beckhoff Automation GmbH.

CANopen® is a registered Community Trademark of CAN in Automation e.V.

DeviceNet™ and EtherNet/IP™ are trademarks of ODVA.

Go!, SensorDAQ, and Vernier are registered trademarks of Vernier Software & Technology. Vernier Software & Technology and vernier.com are trademarks or trade dress.

Xilinx is the registered trademark of Xilinx, Inc.

Taptite and Trilobular are registered trademarks of Research Engineering & Manufacturing Inc.

FireWire® is the registered trademark of Apple Inc.

Linux® is the registered trademark of Linus Torvalds in the U.S. and other countries.

Handle Graphics®, MATLAB®, Real-Time Workshop®, Simulink®, Stateflow®, and xPC TargetBox® are registered trademarks, and TargetBox™ and Target Language Compiler™ are trademarks of The MathWorks, Inc.

Tektronix®, Tek, and Tektronix, Enabling Technology are registered trademarks of Tektronix, Inc.

The Bluetooth® word mark is a registered trademark owned by the Bluetooth SIG, Inc.

The ExpressCard™ word mark and logos are owned by PCMCIA and any use of such marks by National Instruments is under license.

The mark LabWindows is used under a license from Microsoft Corporation. Windows is a registered trademark of Microsoft Corporation in the United States and other countries.

Other product and company names mentioned herein are trademarks or trade names of their respective companies.

Members of the National Instruments Alliance Partner Program are business entities independent from National Instruments and have no agency, partnership, or joint-venture relationship with National Instruments.

Patents

For patents covering National Instruments products/technology, refer to the appropriate location: **Help»Patents** in your software, the `patents.txt` file on your media, or the *National Instruments Patent Notice* at `ni.com/patents`.

Export Compliance Information

Refer to the *Export Compliance Information* at `ni.com/legal/export-compliance` for the National Instruments global trade compliance policy and how to obtain relevant HTS codes, ECCNs, and other import/export data.

WARNING REGARDING USE OF NATIONAL INSTRUMENTS PRODUCTS

(1) NATIONAL INSTRUMENTS PRODUCTS ARE NOT DESIGNED WITH COMPONENTS AND TESTING FOR A LEVEL OF RELIABILITY SUITABLE FOR USE IN OR IN CONNECTION WITH SURGICAL IMPLANTS OR AS CRITICAL COMPONENTS IN ANY LIFE SUPPORT SYSTEMS WHOSE FAILURE TO PERFORM CAN REASONABLY BE EXPECTED TO CAUSE SIGNIFICANT INJURY TO A HUMAN.

(2) IN ANY APPLICATION, INCLUDING THE ABOVE, RELIABILITY OF OPERATION OF THE SOFTWARE PRODUCTS CAN BE IMPAIRED BY ADVERSE FACTORS, INCLUDING BUT NOT LIMITED TO FLUCTUATIONS IN ELECTRICAL POWER SUPPLY, COMPUTER HARDWARE MALFUNCTIONS, COMPUTER OPERATING SYSTEM SOFTWARE FITNESS, FITNESS OF COMPILERS AND DEVELOPMENT SOFTWARE USED TO DEVELOP AN APPLICATION, INSTALLATION ERRORS, SOFTWARE AND HARDWARE COMPATIBILITY PROBLEMS, MALFUNCTIONS OR FAILURES OF ELECTRONIC MONITORING OR CONTROL DEVICES, TRANSIENT FAILURES OF ELECTRONIC SYSTEMS (HARDWARE AND/OR SOFTWARE), UNANTICIPATED USES OR MISUSES, OR ERRORS ON THE PART OF THE USER OR APPLICATIONS DESIGNER (ADVERSE FACTORS SUCH AS THESE ARE HEREAFTER COLLECTIVELY TERMED "SYSTEM FAILURES"). ANY APPLICATION WHERE A SYSTEM FAILURE WOULD CREATE A RISK OF HARM TO PROPERTY OR PERSONS (INCLUDING THE RISK OF BODILY INJURY AND DEATH) SHOULD NOT BE RELIANT SOLELY UPON ONE FORM OF ELECTRONIC SYSTEM DUE TO THE RISK OF SYSTEM FAILURE. TO AVOID DAMAGE, INJURY, OR DEATH, THE USER OR APPLICATION DESIGNER MUST TAKE REASONABLY PRUDENT STEPS TO PROTECT AGAINST SYSTEM FAILURES, INCLUDING BUT NOT LIMITED TO BACK-UP OR SHUT DOWN MECHANISMS. BECAUSE EACH END-USER SYSTEM IS CUSTOMIZED AND DIFFERS FROM NATIONAL INSTRUMENTS' TESTING PLATFORMS AND BECAUSE A USER OR APPLICATION DESIGNER MAY USE NATIONAL INSTRUMENTS PRODUCTS IN COMBINATION WITH OTHER PRODUCTS IN A MANNER NOT EVALUATED OR CONTEMPLATED BY NATIONAL INSTRUMENTS, THE USER OR APPLICATION DESIGNER IS ULTIMATELY RESPONSIBLE FOR VERIFYING AND VALIDATING THE SUITABILITY OF NATIONAL INSTRUMENTS PRODUCTS WHENEVER NATIONAL INSTRUMENTS PRODUCTS ARE INCORPORATED IN A SYSTEM OR APPLICATION. INCLUDING, WITHOUT LIMITATION, THE APPROPRIATE DESIGN, PROCESS AND SAFETY LEVEL OF SUCH SYSTEM OR APPLICATION.

Compliance

Electromagnetic Compatibility Information

This product was tested and complies with the regulatory requirements and limits for electromagnetic compatibility (EMC) as stated in the product specifications. These requirements and limits are designed to provide reasonable protection against harmful interference when the product is operated in its intended operational electromagnetic environment. This product is intended for use in industrial locations. There is no guarantee that harmful interference will not occur in a particular installation, when the product is connected to a test object, or if the product is used in residential areas. To minimize the potential for the product to cause interference to radio and television reception or to experience unacceptable performance degradation, install and use this product in strict accordance with the instructions in the product documentation. Furthermore, any changes or modifications to the product not expressly approved by National Instruments could void your authority to operate it under your local regulatory rules.



Caution To ensure the specified EMC performance, product installation requires either special considerations or user-installed, add-on devices. See the product installation instructions for further information.



Caution To ensure the specified EMC performance, operate this product only with shielded cables and accessories.

Contents

About This Manual

How to Use the Documentation Set.....	xi
Conventions	xi
Related Documentation.....	xii

Chapter 1

Introduction

Benefits of PXI Express.....	1-1
NI PXIe-8820.....	1-2
Description	1-2
Functional Overview	1-2
NI PXIe-8820 Functional Description	1-2
National Instruments Software	1-4

Chapter 2

Installation and Configuration

Installing the NI PXIe-8820.....	2-1
How to Remove the Controller from the PXI Express Chassis.....	2-4
BIOS Setup Utility.....	2-4
Accessing BIOS Setup Utility.....	2-4
Main Setup Menu	2-5
Advanced Setup Menu	2-6
SATA Configuration Submenu.....	2-7
CPU Configuration Submenu	2-7
Video Configuration Submenu	2-8
Power/Wake Configuration Submenu	2-8
USB Configuration Submenu	2-9
Serial/Parallel Port Configuration Submenu.....	2-10
Serial Port Configuration Submenu.....	2-10
Parallel Port Configuration Submenu.....	2-10
Memory Configuration Submenu	2-11
LabVIEW RT Setup Menu.....	2-11
LabVIEW RT Configuration Overrides Submenu.....	2-12
Boot Setup Menu.....	2-12
Boot Settings Configuration Submenu	2-13
Hard Drive BBS Priorities Submenu	2-14
CD/DVD ROM Drive BBS Priorities Submenu.....	2-14

Floppy Drive BBS Priorities Submenu	2-14
Network Device BBS Priorities Submenu.....	2-14
Security Menu	2-14
Save & Exit Menu.....	2-15
BIOS Diagnostic Utilities.....	2-16
Accessing BIOS Diagnostic Utilities.....	2-16
Hard Drive Diagnostic Utility.....	2-16
Memory Diagnostic Utility	2-16
System CMOS.....	2-17
LabVIEW RT Installation	2-18
LabVIEW RT Software Installation	2-18
LabVIEW RT Configuration Switches	2-19
Drivers and Software.....	2-22
PXI Express Features	2-22
PXI Express Trigger Connectivity.....	2-22
PXI Express Chassis Configuration	2-22
PXI Express System Configuration	2-23
Upgrading RAM.....	2-24
Hard Drive Recovery.....	2-25
Installing an OS.....	2-25
Installing from a USB CD/DVD-ROM	2-25

Chapter 3

I/O Information

Front Panel Connectors	3-1
Front Panel.....	3-2
DisplayPort.....	3-3
COM1.....	3-5
Ethernet	3-6
Parallel Port.....	3-7
Universal Serial Bus.....	3-9
Trigger.....	3-11
Front Panel Features	3-12
Data Storage	3-12

Chapter 4

Common Configuration Questions

General Questions	4-1
Boot Options.....	4-2
Cables and Connections	4-3
Software Driver Installation	4-4
Upgrade Information	4-4
PXI Express Configuration.....	4-6

**Chapter 5
Troubleshooting**

**Appendix A
Specifications**

**Appendix B
Technical Support and Professional Services**

Glossary

Index

About This Manual

This manual contains detailed instructions for installing and configuring the National Instruments PXIe-8820 embedded computer kit.

How to Use the Documentation Set

Begin by reading the *NI PXIe-8820 Installation Guide*, a brief quick-start guide that describes how to install and get started with your controller.

This manual, the *NI PXIe-8820 User Manual*, contains more details about changing the installation or configuration from the defaults and using the hardware.

Conventions

The following conventions appear in this manual:

»

The » symbol leads you through nested menu items and dialog box options to a final action. The sequence **Options»Settings»General** directs you to pull down the **Options** menu, select the **Settings** item, and select **General** from the last dialog box.



This icon denotes a tip, which alerts you to advisory information.



This icon denotes a note, which alerts you to important information.



This icon denotes a caution, which advises you of precautions to take to avoid injury, data loss, or a system crash.

bold

Bold text denotes items that you must select or click in the software, such as menu items and dialog box options. Bold text also denotes parameter names.

italic

Italic text denotes variables, emphasis, a cross-reference, or an introduction to a key concept. Italic text also denotes text that is a placeholder for a word or value that you must supply.

monospace

Text in this font denotes text or characters that you should enter from the keyboard, sections of code, programming examples, and syntax examples. This font is also used for the proper names of disk drives, paths, directories, programs, subprograms, subroutines, device names, functions, operations, variables, filenames, and extensions.

monospace bold

Bold text in this font denotes the messages and responses that the computer automatically prints to the screen. This font also emphasizes lines of code that are different from the other examples.

Related Documentation

The following documents contain information you may find helpful as you read this manual:

- *PICMG EXP.0 R1.0 CompactPCI Express Specification*, PCI Industrial Computers Manufacturers Group
- IEEE Standard P1284.1-1997 (*C/MM*) *Standard for Information Technology for Transport Independent Printer/System Interface*
- *PCI Express Base Specification*, Revision 2.0, PCI Special Interest Group
- *PXI-5 PXI Express Hardware Specification*, Revision 1.0, PXI Systems Alliance
- *PXI-6 PXI Express Software Specification*, Revision 1.0, PXI Systems Alliance
- *Serialized IRQ Support for PCI Systems Specification*, Revision 6.0, Compaq Computer et al.
- *ExpressCard Standard*, Release 1.0, PCMCIA

Introduction

This chapter provides overview information for PXI Express and the NI PXIe-8820 embedded controller.

Benefits of PXI Express

The PXI (PCI eXtensions for Instrumentation) industry standard, an open specification governed by the PXI Systems Alliance (PXISA), has quickly gained adoption and grown in prevalence in test, measurement, and control systems since its release in 1998. One of the key elements driving the rapid adoption of PXI is its use of PCI in the communication backplane. As the commercial PC industry has improved the available bus bandwidth by evolving PCI to PCI Express, PXI is now able to meet even more application needs by integrating PCI Express into the PXI standard. By taking advantage of PCI Express technology in the backplane, PXI Express increases the maximum PXI bandwidth from up to 132 MB/s to up to 2 GB/s for a more than 45x improvement in bandwidth.

PXI Express maximizes both hardware and software compatibility with PXI modules. PXI Express hybrid slots deliver both PCI and PCI Express signaling to accept devices that use PXI communication and triggering or the newer PXI Express standard. Software compatibility is maintained because PCI Express uses the same OS and driver model as PCI, resulting in complete software compatibility among PCI-based systems, for example PXI, and PCI Express-based systems such as PXI Express.

PXI Express, like PXI, leverages from the CompactPCI specification to define a rugged, modular form factor that offers superior mechanical integrity and easy installation and removal of hardware components. PXI Express products offer higher and more carefully defined levels of environmental performance required by the shock, vibration, temperature, and humidity extremes of industrial environments. Mandatory environmental testing and active cooling is added to the CompactPCI mechanical specification to ease system integration and ensure multivendor interoperability.

The demanding timing and synchronization requirements of instrumentation systems are met by the integrated features of PXI Express. Not only are the trigger bus, 10 MHz system reference clock, and star trigger bus available in PXI retained by PXI Express, but new timing and synchronization features that include a 100 MHz differential system reference clock for the synchronization of multiple modules and three differential star trigger buses for the distribution of precise clock and trigger signals have been added. Differential timing and synchronization signals provide PXI Express systems with increased noise immunity and the ability to transmit clock signals at higher frequencies.

NI PXIe-8820

Description

The NI PXIe-8820 PXI Express/CompactPCI Express embedded computer is a high performance PXI Express/CompactPCI Express-compatible system controller. The NI PXIe-8820 controller integrates standard I/O features in a single unit by using state-of-the-art packaging. Combining an NI PXIe-8820 embedded controller with a PXI Express-compatible chassis, such as the NI PXIe-1082, results in a fully PC-compatible computer in a compact, rugged package.

The NI PXIe-8820 has an Intel® Celeron® 1020E processor (2.2 GHz dual core processor), all the standard I/O, and a 250 GB (or larger) hard drive.

The standard I/O on each module includes one DisplayPort video, one RS-232 serial port, a parallel port, four Hi-Speed USB ports, one Gigabit Ethernet, a reset button, and a PXI trigger.

Functional Overview

This section contains functional descriptions of each major logic block on the NI PXIe-8820 embedded computer.

NI PXIe-8820 Functional Description

The NI PXIe-8820 is a modular PC in a PXI Express 3U-size form factor. Figure 1-1 is a functional block diagram of the NI PXIe-8820. Following the diagram is a description of each logic block shown.

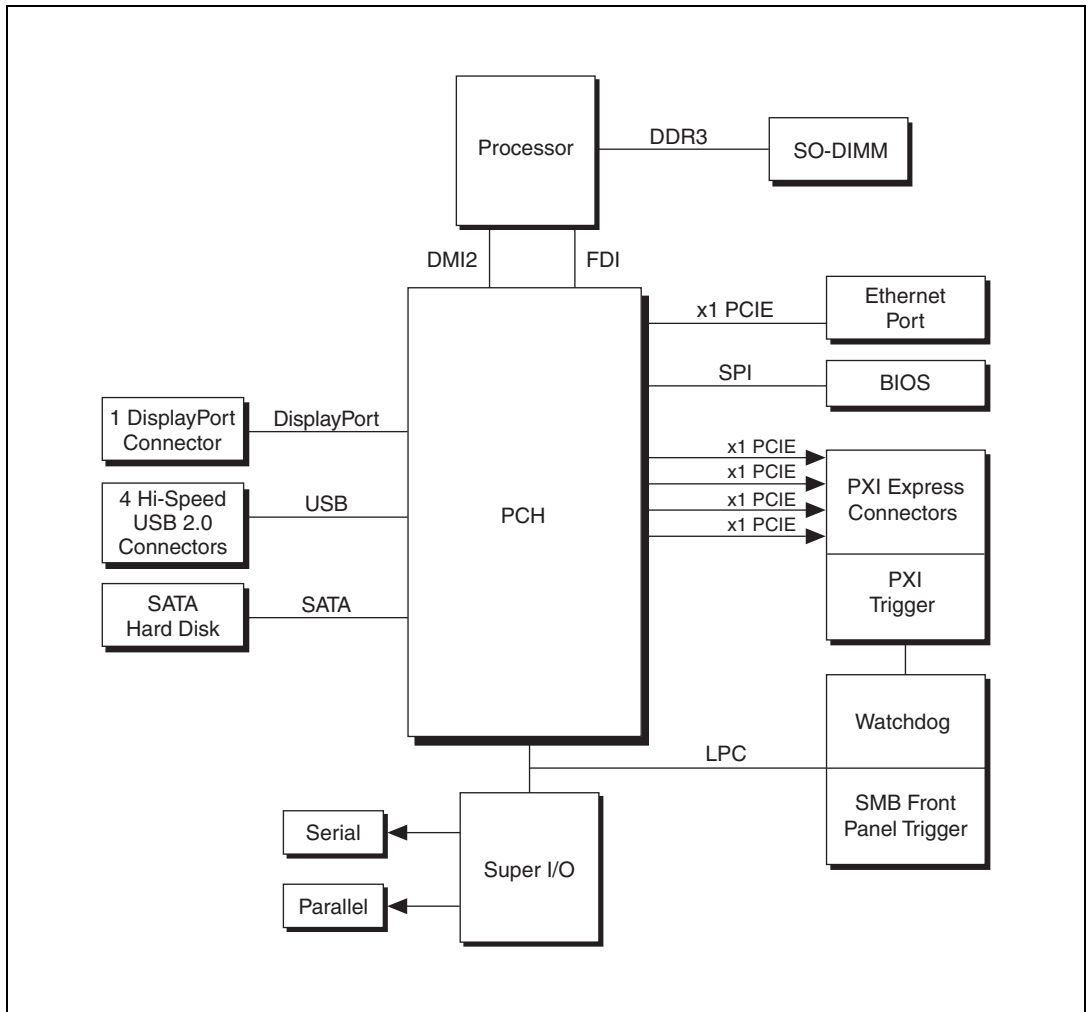

Figure 1-1. NI PXIe-8820 Block Diagram

The NI PXIe-8820 consists of the following logic blocks on the CPU module and the I/O (daughter card) module. The CPU module has the following logic blocks:

- The *processor* is an Intel® Celeron® 1020E processor (2M Cache, 2.2 GHz). The processor connects to the SO-DIMM block through the DDR3 interface supporting up to 1333MHz SO-DIMMs, the PCH through a x4 DMI2 (Direct Media Interface) interface supporting up to 5 GT/s per lane and through x4 FDI (Flexible Display Interface) supporting up to 2.7 GT/s per lane.

- The *SO-DIMM* block consists of one 64-bit DDR3 SDRAM socket that can hold up to 8 GB of memory.
- The *PCH* (Platform Controller Hub) provides the DisplayPort, USB, PCI Express, LPC and SPI interfaces that connect to the peripherals on the NI PXIe-8820.
- The *DisplayPort* block consists of 1 DisplayPort connector.
- The *USB* block consists of 4 Hi-Speed USB 2.0 connectors.
- The *Ethernet Port* block consists of an Intel® 82579LM Gigabit Network Connection.
- The *Super I/O* block connects to 1 serial port and 1 ECP/EPP parallel port.
- The *SMB Front Panel Trigger* provides a routable connection of the PXI triggers to/from the SMB on the front panel.
- The *Watchdog* block consists of a watchdog timer that can reset the controller or generate triggers.
- The *PXI Express Connectors* connect the NI PXIe-8820 to the PXI Express/CompactPCI Express backplane.

National Instruments Software

National Instruments has developed several software tools you can use with the NI PXIe-8820.

National Instruments' hardware and software work together to help you make the most of your PXI Express system. The LabVIEW, Measurement Studio, and LabWindows™/CVI™ application development environments combine with leading hardware drivers such as NI-DAQmx to provide exceptional control of NI hardware. Instrument drivers are available at ni.com/idnet to simplify communication with instruments over a variety of buses.

LabVIEW is a powerful and easy-to-use graphical programming environment you can use to acquire data from thousands of different instruments including USB, IEEE 488.2, VXI, serial, PLCs, and plug-in boards. LabVIEW helps you convert acquired data into meaningful results using powerful data analysis routines. Add-on tools provide additional specialized functionality. For more information visit ni.com/labview and ni.com/toolkits.

If you prefer to use Microsoft's Visual Basic, Visual C++, and Visual Studio .NET for the core of your application, Measurement Studio

adds tools for Measurement and Automation to each language. For more information visit ni.com/mstudio.

LabWindows/CVI is an interactive ANSI C programming environment designed for building virtual instrument applications. LabWindows/CVI delivers a drag-and-drop editor for building user interfaces, a complete ANSI C environment for building your test program logic, and a collection of automated code generation tools, as well as utilities for building automated test systems, monitoring applications, or laboratory experiments. For more information visit ni.com/lwcvl.

NI-DAQmx provides an extensive library of functions that you can call from your application development environment or interactive environment such as NI Signal Express. These functions provide an intuitive API for National Instruments' multifunction DAQ products. Features available include analog input (A/D conversion), buffered data acquisition (high-speed A/D conversion), analog output (D/A conversion), waveform generation, digital I/O, counter/timer operations, SCXI signal conditioning, RTSI or PXI synchronization, self-calibration, messaging, and acquiring data to extended memory. For more information visit ni.com/daq.

National Instruments' Modular Instruments use specialized drivers suited to each product's specialization. Express VIs provide customized, interactive programming of instruments in a single interface and soft front panels provide an interface for testing the functionality of each instrument with no programming required. NI Switches, DMMs, High-Speed DIO, High-Speed Digitizers, and Sources each have customized drivers for high-end modular instrumentation systems. RF applications leverage two drivers, NI-RFSG and NI-RFSA and Dynamic Signal Acquisition is available through NI-DAQmx. For more information visit ni.com/modularinstruments.

You can expand the timing and triggering functionality of your PXI system with PXI Timing and Synchronization products. These products provide precision clock sources, custom routing of triggers for multi-chassis synchronization, clock sharing, and more and are programmed with NI-Sync. For more information visit ni.com/pxi.

NI-VISA is the National Instruments implementation of the VISA specification. VISA is a uniform API for communicating and controlling USB, Serial, GPIB, PXI, VXI, and various other types of instruments. This API aids in the creation of portable applications and instrument drivers. For

information on writing your own PXI instrument driver with NI-VISA, refer to the *NI-VISA Getting Started Manual* and the `readme.txt` file in the NI-VISA directory. For more information visit ni.com/visa.

With LabVIEW for Linux and support for over two hundred devices on Linux with the NI-DAQmx driver, you can now create Virtual Instruments based on the Linux OS. Instrument control in Linux has been improved by the NI-VISA driver for Linux and NI Modular Instruments are partially supported. For more information visit ni.com/linux.

Installation and Configuration

This chapter contains information about installing and configuring your NI PXIe-8820 controller.

Installing the NI PXIe-8820

This section contains general installation instructions for the NI PXIe-8820. Consult your PXI Express chassis user manual for specific instructions and warnings.

1. Plug in your chassis before installing the NI PXIe-8820. The power cord grounds the chassis and protects it from electrical damage while you install the module.



Caution To protect both yourself and the chassis from electrical hazards, leave the chassis powered off until you finish installing the NI PXIe-8820 module.

2. Remove any filler panels blocking access to the system controller slot (Slot 1) in the chassis.
3. Touch the metal part of the case to discharge any static electricity that might be on your clothes or body.

4. Remove the protective plastic covers from the four bracket-retaining screws as shown in Figure 2-1.

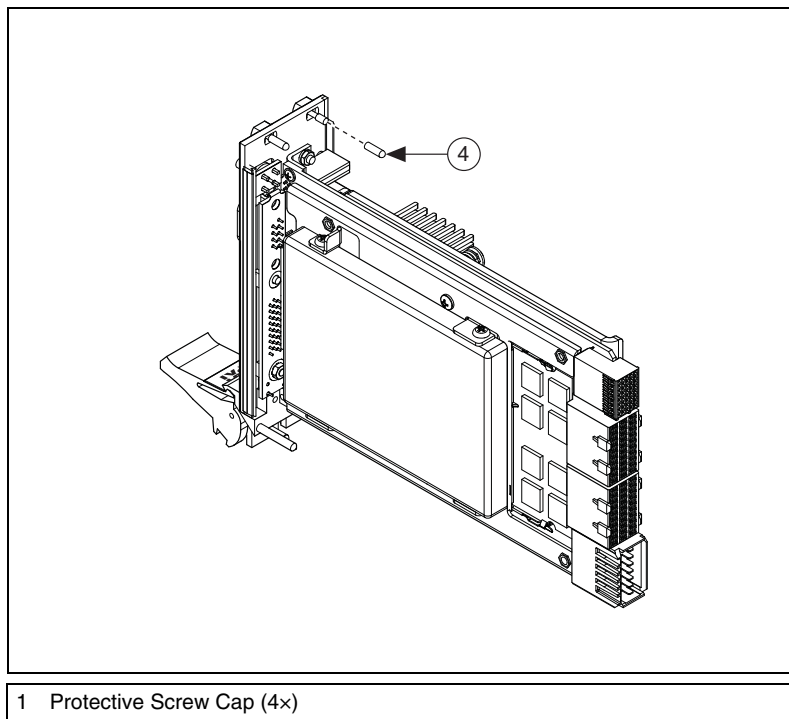

Figure 2-1. Removing Protective Screw Caps

5. Make sure the injector/ejector handle is in its downward position. Align the NI PXIe-8820 with the card guides on the top and bottom of the system controller slot.



Caution Do *not* raise the injector/ejector handle as you insert the NI PXIe-8820. The module will not insert properly unless the handle is in its downward position so that it does not interfere with the injector rail on the chassis.

6. Hold the handle as you slowly slide the module into the chassis until the handle catches on the injector/ejector rail.
7. Raise the injector/ejector handle until the module firmly seats into the backplane receptacle connectors. The front panel of the NI PXIe-8820 should be even with the front panel of the chassis.
8. Tighten the four bracket-retaining screws on the top and bottom of the front panel to secure the NI PXIe-8820 to the chassis.

9. Check the installation.
10. Connect the keyboard and mouse to the appropriate connectors. If you are using a PS/2 keyboard and a PS/2 mouse, a Y-splitter adapter is available to connect both to a single USB connector. Refer to Figure 4-1, *Y-Splitter Cable*.
11. Connect the DisplayPort monitor video cable to the DisplayPort connector, or use the DisplayPort-to-VGA adapter included with your controller to connect a VGA monitor to the DisplayPort connector.
12. Connect devices to ports as required by your system configuration.
13. Power on the chassis.
14. Verify that the controller boots. If the controller does not boot, refer to the *What if the NI PXIe-8820 does not boot?* section of Chapter 5, *Troubleshooting*.

Figure 2-2 shows an NI PXIe-8820 installed in the system controller slot of a National Instruments NI PXIe-1082 chassis.

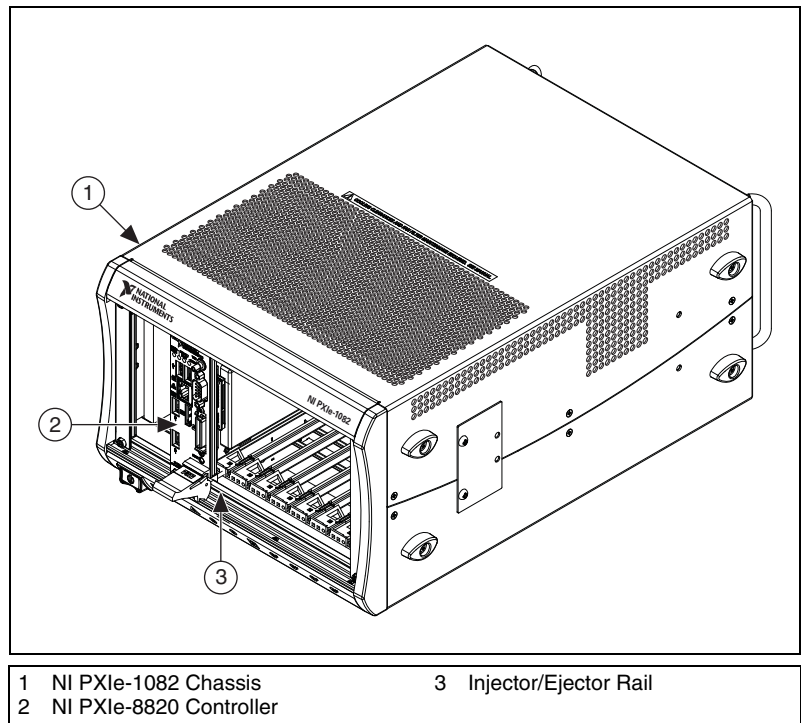

Figure 2-2. NI PXIe-8820 Controller Installed in a PXI Express Chassis

How to Remove the Controller from the PXI Express Chassis

The NI PXIe-8820 controller is designed for easy handling. To remove the unit from the PXI Express chassis, complete the following steps.

1. Power off the chassis.
2. Unscrew the 4 bracket-retaining screws in the front panel.
3. Press the injector/ejector handle down.
4. Slide the unit out of the chassis.



Note If the PXI Express chassis Inhibit Mode Selector Switch is not in the Default position, any attempt to shut down the NI PXIe-8820 through the push button reset or using Windows will result in the controller Power OK LED blinking. The user will be required to use the Remote Inhibit pin on the Remote Inhibit and Voltage Monitoring Connector to turn off the chassis. Refer to the PXI Express chassis user manual for details on the functionality of the Remote Inhibit and Voltage Monitoring controls.

BIOS Setup Utility

You can change the NI PXIe-8820 configuration settings in the BIOS setup program. The BIOS is the low-level interface between the hardware and operating system software that configures and tests your hardware when you boot the system. The BIOS setup program includes menus for configuring settings and enabling NI PXIe-8820 controller features.

Most users do not need to use the BIOS setup program, as the NI PXIe-8820 controller ships with default settings that work well for most configurations.



Caution Changing BIOS settings may lead to incorrect controller behavior and possibly an unbootable controller. If this happens, follow the instructions for restoring default settings in the *System CMOS* section. In general, do *not* change a setting unless you are absolutely certain what it does.

Accessing BIOS Setup Utility

Complete the following steps to start the BIOS setup program.

1. Power on or reboot your NI PXIe-8820 controller.
2. When the message **Press to enter setup** appears, press the <Delete> key. The setup program loads after a short delay.

The **Main** menu is displayed when you first enter the BIOS setup program.

Use the following keys to navigate through the BIOS setup program:

- **Left Arrow, Right Arrow**—Use these keys to move between the different setup menus. If you are in a submenu, these keys have no effect, and you must press <Esc> to leave the submenu first. (To use the arrows on the numeric keypad, you must turn off Num Lock.)
- **Up Arrow, Down Arrow**—Use these keys to move between the options within a setup menu. (To use the arrows on the numeric keypad, you must turn off Num Lock.)
- **<Enter>**—Use this key either to enter a submenu or display all available settings for a highlighted configuration option.
- **<Esc>**—Use this key to return to the parent menu of a submenu. At the top-level menus, this key serves as a shortcut to the **Exit** menu.
- **<+> and <->**—Use these keys to cycle between all available settings for a selected configuration option.
- **<Tab>**—Use this key to select time and date fields.
- **<F9>**—Use this key to load the optimal default values for BIOS configuration settings. The optimal default values are the same as the shipping configuration default values.

Main Setup Menu

The most commonly accessed and modified BIOS settings are in the **Main** setup menu. The **Main** setup menu reports the following configuration information:

- **BIOS Version and Build Date**—These values indicate the version of the NI PXIe-8820 controller BIOS and the date on which the BIOS was built.
- **Embedded Firmware Version**—This value helps identify the built-in hardware capabilities.
- **Processor Type, Base Processor Frequency, and Active Processor Cores**—These values indicate the type of processor used in the NI PXIe-8820 controller, the speed of the processor, and the maximum number of processor cores.
- **Total Memory**—This value indicates the size of system RAM detected by the BIOS.
- **PXIe Chassis Information**—These values indicate the overall chassis link configuration, the link width of each link, and the link speed of each link.

The **Main** setup menu also includes the following settings:

- **System Date**—This setting controls the date, which is stored in a battery-backed real-time clock. Most operating systems also include a way to change this setting. Use <+> and <-> in conjunction with <Enter> and <Tab> to change these values.
- **System Time**—This setting controls the time of day, which is stored in a battery-backed real-time clock. Most operating systems also include a way to change this setting. Use <+> and <-> in conjunction with <Enter> and <Tab> to change these values.

Advanced Setup Menu

This menu contains BIOS settings that normally do not require modification. If you have specific problems such as unbootable disks or resource conflicts, you may need to examine these settings.



Caution Changing settings in this menu may result in an unstable or unbootable controller. If this happens, follow the procedures outlined in the *System CMOS* section to restore BIOS settings to their factory defaults.

The **Advanced** setup menu includes the following settings and submenus:

- **SATA Configuration**—Use this setting to access the **SATA Configuration** submenu. Refer to the *SATA Configuration Submenu* section for more information.
- **CPU Configuration**—Use this setting to access the **CPU Configuration** submenu. Refer to the *CPU Configuration Submenu* section for more information.
- **Video Configuration**—Use this setting to access the **Video Configuration** submenu. Refer to the *Video Configuration Submenu* section for more information.
- **Power/Wake Configuration**—Use this setting to access the **Power/Wake Configuration** submenu. Refer to the *Power/Wake Configuration Submenu* section for more information.
- **USB Configuration**—Use this setting to access the **USB Configuration** submenu. Refer to the *USB Configuration Submenu* section for more information.
- **Serial/Parallel Port Configuration**—Use this setting to access the **Serial/Parallel Port Configuration** submenu. Refer to the *Serial/Parallel Port Configuration Submenu* section for more information.

- **Memory Configuration**—Use this setting to access the **Memory Configuration** submenu. Refer to the [Memory Configuration Submenu](#) section for more information.

SATA Configuration Submenu

Use this submenu to apply alternate settings to the hard disk drive (HDD) interfaces. Normally, you do not need to modify these settings, as the factory default settings provide the most compatible and optimal configuration possible.

- **SATA Controller**—This setting specifies whether or not the onboard SATA controller is enabled or disabled. The default value is **Enabled**.
 - **SATA Mode Selection**—This setting determines whether AHCI mode is enabled or disabled for the SATA port. Some older operating systems do not support AHCI mode. You can use this setting to disable AHCI mode and enable IDE mode so that non-compatible OSes function correctly. The default value is **AHCI**.
- **Internal Drive (SATA)**—This item displays the onboard SATA drive detected in the system.

CPU Configuration Submenu

Use this submenu to apply alternate settings to the CPU. Normally, you do not need to modify these settings, as the factory default settings provide the most compatible and optimal configuration possible.

- **Enabled CPU Cores**—This setting selects the number of active CPU cores for the processor. Valid values are All or 1. The default value is **All**.
- **C-States**—This setting enables or disables CPU power management. The default value is **Enabled**. Enabling C-States allows the processor to put idle CPU cores to sleep, allowing active cores to run at higher than base frequencies when Turbo Boost is enabled. Enabling C-States can increase application jitter, so care should be taken when enabling this setting on a Real Time system. When the BIOS is configured to boot LabVIEW Real-time, C-States will be automatically disabled. In order to manually enable C-States when in LabVIEW Real-Time mode, see the [LabVIEW RT Configuration Overrides Submenu](#).
- **Hardware Prefetcher**—This setting enables or disables CPU cache hardware prefetching. The default value is **Enabled**. Enabling hardware prefetching can increase system performance for some

applications, but can cause control algorithms to behave less deterministically.

- **Adjacent Cache Line Prefetch**—This setting enables or disables prefetching of adjacent cache lines from memory to the CPU cache. The default value is **Enabled**. Enabling adjacent cache line prefetching can increase system performance for some applications, but can cause control algorithms to behave less deterministically.

Video Configuration Submenu

Use this submenu to apply alternate settings to the video configuration. Normally, you do not need to modify these settings, as the factory default settings provide the most compatible and optimal configuration possible.

- **Primary Display**—This setting specifies which video adapter the BIOS should use as the primary adapter if more than one is present. To use an external video adapter as the primary graphics adapter, choose **Add-in Board Video**. The default value is **Onboard Video**.

Power/Wake Configuration Submenu

Use this submenu to apply alternate configurations to the power and wake features of the chipset and controller. Normally, you do not need to modify these settings, as the factory default settings provide the most compatible and optimal configuration possible.

- **Restore After Power Loss**—This setting specifies the power state that the controller should return to after AC power is lost. Valid values are **Stay Off** and **Turn On**. The default is **Stay Off**. When set to **Stay Off**, the controller will return to the soft off power state after AC power is restored. When set to **Turn On**, the controller will power on when AC power is restored.
- **Power Button Off Behavior**—This setting specifies how the PXI Express power button should behave. Valid options are **Normal**, **Force Off**, and **Disabled**. The default value is **Normal**. When set to **Normal**, the power button will be controlled by the OS. When set to **Force Off**, the system will immediately power off when the power button is pressed, overriding any OS-specific power button policy. When set to **Disabled**, pressing the power button has no effect. The **Disabled** option should only be used in conjunction with the PXI Express chassis' inhibit mode switch.
- **PXIe Backplane WAKE#**—This setting enables or disables a PXI Express peripheral module's ability to wake a powered-off system. The default value is **Disabled**.

- **SMBus ALERT#**—This setting enables or disables a System Management device's ability to wake a powered off system by asserting the ALERT# signal. The default value is **Disabled**.

USB Configuration Submenu

Use this submenu to apply alternate configurations to the USB ports. Normally, you do not need to modify these settings, as the factory default settings provide the most compatible and optimal configuration possible.

- **USB Devices**—This item lists the total number of devices detected in the system, categorized by device type.
- **Legacy USB Support**—This setting specifies whether or not legacy USB support is enabled. Legacy USB support refers to the ability to use a USB keyboard and mouse during system boot or in a legacy operating system such as DOS. The default value is **Enabled**. This option is automatically disabled when booting LabVIEW Real-Time in order to reduce application jitter.
- **Overcurrent Reporting**—This setting allows the BIOS to notify the operating system of any USB ports which source too much current. The default value for this setting is **Disabled**.
- **Transfer Timeout**—This setting specifies the timeout value for Control, Bulk, and Interrupt USB transfers. The default value for this setting is **20** seconds.
- **Device Reset Timeout**—This setting specifies the number of seconds the Power-On Self Test will wait for a USB mass storage device to start. The default is **20** seconds.
- **Device Power-up Delay**—This setting specifies the maximum time a device will take before it properly reports itself to the host controller. When set to **Auto**, a root port is granted 100 ms, and for a hub port, the delay value is taken from the hub descriptor. The default value for this setting is **Auto**.
- **Device Power-Up Delay in Seconds**—This setting specifies the number of seconds the Power-On Self Test will wait for a USB device or hub to power on. This setting is only visible if **Device Power-Up Delay** is set to **Manual**. The default is **5** seconds.

In addition, the following option is available for each detected device if a USB mass storage device is present:

- **Emulation Type**—This setting specifies how the BIOS will present the USB mass storage device to the system. This option can be used to present a USB mass storage device as a floppy, Zip, hard disk, or CD-ROM drive. The default is **Auto**, which allows the BIOS to treat

small USB flash disk drives as floppy drives and larger USB flash disk drives as hard disk drives.

Serial/Parallel Port Configuration Submenu

Use this submenu to apply alternate configurations to the serial and parallel ports. Normally, you do not need to modify these settings, as the factory default settings provide the most compatible and optimal configuration possible.

- **Serial Port Configuration**—Use this setting to access the **Serial Port Configuration** submenu. Refer to the *Serial Port Configuration Submenu* section for more information.
- **Parallel Port Configuration**—Use this setting to access the **Parallel Port Configuration** submenu. Refer to the *Parallel Port Configuration Submenu* section for more information.

Serial Port Configuration Submenu

- **Serial Port**—This setting enables or disables the onboard serial port. The default value is **Enabled**.
- **Device Settings**—This item displays the current base address and interrupt request level (IRQ) information for the onboard serial port.
- **Change Settings**—This setting changes the base address and interrupt request level (IRQ) information for the onboard serial port. The default value is **Auto**.

Parallel Port Configuration Submenu

- **Parallel Port**—This setting enables or disables the onboard parallel port. The default value is **Enabled**.
- **Device Settings**—This item displays the current base address and interrupt request level (IRQ) information for the onboard parallel port.
- **Change Settings**—This setting changes the base address and interrupt request level (IRQ) information for the onboard parallel port. The default value is **Auto**. Note that the options available vary based upon the **Device Mode** selected for the parallel port.
- **Device Mode**—This setting enables alternate modes of operation for the parallel port. Usually the default setting works for all applications. The default is **STD Printer Mode**.

Memory Configuration Submenu

Use this submenu to apply alternate configurations to the memory. Normally, you do not need to modify these settings, as the factory default settings provide the most compatible and optimal configuration possible.

- **Memory Performance Mode**—This setting enables or disables performance mode for memory. The fault value is **Disabled**.

LabVIEW RT Setup Menu

Use this menu to configure boot options for LabVIEW RT if it is installed on the controller. If you are not using LabVIEW RT, you should leave these settings at default.



Note The settings below override the behavior of the switches shown in Figure 2-4. Refer to the [LabVIEW RT Configuration Switches](#) section for more information. To use the settings from the switches, select **Use Switch Setting** for each option.

- **Boot Configuration**—This setting selects whether the controller should boot LabVIEW RT, LabVIEW RT Safe Mode, or an installed OS such as Windows 7. The default is **Use Switch Setting**.
- **Reset IP Address**—If the controller is deployed to a different subnet from which it was originally configured, or if the current IP address is invalid, use this switch to reset the IP address and other TCP/IP settings to their factory defaults during LabVIEW RT startup. The default is **Use Switch Setting**.



Note By default, the target will automatically attempt to connect to the network using DHCP. If the target is unable to initiate a DHCP connection, the target connects to the network with a link-local IP address or 169.254.x.x.

- **Disable Startup VI**—If the controller becomes inaccessible because of a startup VI, this switch can prevent VIs from automatically running at startup. The default is **Use Switch Setting**.
- **LabVIEW RT Configuration Overrides**—Use this setting to access the **LabVIEW RT Configuration Overrides** submenu. Refer to the *LabVIEW RT Configuration Overrides Submenu* section for more information.

LabVIEW RT Configuration Overrides Submenu

In order to minimize jitter when booting into LabVIEW Real-Time mode, the features listed here are automatically disabled. These features can be manually enabled. Refer to the *CPU Configuration Submenu* for specific details on what each feature enables.

Use this submenu to apply alternate settings to the controller's sound device.

- **CPU C-States**—The default is **Use RT Default**.

Boot Setup Menu

Use this menu to configure settings related to the boot process and boot device priority.

- **Boot Settings Configuration**—Use this setting to access the **Boot Settings Configuration** submenu. Refer to the *Boot Settings Configuration Submenu* section for more information.
- **SCSI Drive Boot**—This setting specifies whether or not boot support is enabled for legacy mass storage devices, such as SCSI drives. When enabled, legacy mass storage controllers with boot support will be displayed in the **Boot Option Priorities** menu. The default value is **Enabled**.
- **PXE Network Boot**—This setting specifies whether or not the PXE network boot agent is enabled. When enabled, the Intel Boot Agent will be displayed in the **Boot Option Priorities** menu, allowing you to boot from a PXE server on the local subnet. Note that the Intel Boot Agent device names are preceded by **IBA GE Slot** in the **Boot Option Priorities** menu. The system must be restarted for this setting to take effect. The default value is **Disabled**.
- **Boot Option Priorities**—These settings specify the order in which the BIOS checks for bootable devices, including the local hard disk drive, removable devices such as USB flash disk drives or USB CD-ROM drives, or the PXE network boot agent. The BIOS will first attempt to

boot from the device associated with **Boot Option #1**, followed by **Boot Option #2**, and **Boot Option #3**. If multiple boot devices are not present, the BIOS setup utility will not display all of these configuration options. To select a boot device, press <Enter> on the desired configuration option and select a boot device from the resulting menu. You can also disable certain boot devices by selecting **Disabled**.



Note Only one device of a given type will be shown in this list. If more than one device of the same type exists, use the *Device BBS Priorities* submenus to re-order the priority of devices of the same type.

The following submenus will be displayed if one or more bootable devices of the corresponding type is present:

- **Hard Drive BBS Priorities**—Use this setting to access the **Hard Drive BBS Priorities** submenu to re-order or disable bootable hard drive devices. Refer to the *Hard Drive BBS Priorities Submenu* section for more information.
- **CD/DVD ROM Drive BBS Priorities**—Use this setting to access the **CD/DVD ROM Drive BBS Priorities** submenu to re-order or disable bootable CD/DVD ROM drive devices. Refer to the *CD/DVD ROM Drive BBS Priorities Submenu* section for more information.
- **Floppy Drive BBS Priorities**—Use this setting to access the **Floppy Drive BBS Priorities** submenu to re-order or disable bootable floppy drive devices. Refer to the *Floppy Drive BBS Priorities Submenu* section for more information.
- **Network Device BBS Priorities**—Use this setting to access the **Network Device BBS Priorities** submenu to re-order or disable bootable network devices. Refer to the *Network Device BBS Priorities Submenu* section for more information.

Boot Settings Configuration Submenu

Use this submenu to apply alternate configurations to boot settings. Normally, you do not need to modify these settings, as the factory default settings provide the most compatible and optimal configuration.

- **Setup Prompt Timeout**—This setting specifies the number of seconds the system will wait for a BIOS Setup menu keypress (the <Delete> key). The default value is **2** seconds.
- **Bootup NumLock State**—This setting specifies the power-on state of the keyboard NumLock setting. The default value is **On**.

Hard Drive BBS Priorities Submenu

- **Boot Option #1, Boot Option #2, Boot Option #3**—These settings specify the boot priority of hard drive devices. The highest priority device is displayed on the main **Boot Option Priorities** list. Optionally, each device can also be **Disabled** if the device should never be used as a boot device.

CD/DVD ROM Drive BBS Priorities Submenu

- **Boot Option #1, Boot Option #2, Boot Option #3**—These settings specify the boot priority of CD/DVD ROM drive devices. The highest priority device is displayed on the main **Boot Option Priorities** list. Optionally, each device can also be **Disabled** if the device should never be used as a boot device.

Floppy Drive BBS Priorities Submenu

- **Boot Option #1, Boot Option #2, Boot Option #3**—These settings specify the boot priority of floppy drive devices. The highest priority device is displayed on the main **Boot Option Priorities** list. Optionally, each device can also be **Disabled** if the device should never be used as a boot device.

Network Device BBS Priorities Submenu

- **Boot Option #1, Boot Option #2, Boot Option #3**—These settings specify the boot priority of network devices. The highest priority device is displayed on the main **Boot Option Priorities** list. Optionally, each device can also be **Disabled** if the device should never be used as a boot device.

Security Menu

Use this menu to enable BIOS security options.

- **Setup Administrator Password**—This setting specifies a password that must be entered to access the BIOS Setup Utility. If only the Administrator's password is set, then this only limits access to the BIOS setup program and is only asked for when entering the BIOS setup program. By default, no password is specified.
- **User Password**—This setting specifies a password that must be entered to access the BIOS Setup Utility or to boot the system. If only the User's password is set, then this is a power on password and must be entered to boot or enter the BIOS setup program. In the BIOS setup

program, the User will have Administrator rights. By default, no password is specified.

Save & Exit Menu

The **Save & Exit** setup menu includes all available options for exiting, saving, and loading the BIOS default configuration. As an alternative to this screen, press <F9> to load optimal BIOS default settings and <F10> to save changes and exit setup.

This setup menu includes the following settings:

- **Save Changes and Reset**—Any changes made to BIOS settings are stored in NVRAM. The setup program then exits and reboots the controller. The <F10> key can also be used to select this option.
- **Discard Changes and Reset**—Any changes made to BIOS settings during this session of the BIOS setup program are discarded. The setup program then exits and reboots the controller. The <Esc> key can also be used to select this option.
- **Save Changes**—Changes made to BIOS settings during this session are committed to NVRAM. The setup program remains active, allowing further changes.
- **Discard Changes**—Any changes made to BIOS settings during this session of the BIOS setup program are discarded. The BIOS setup continues to be active.
- **Restore Factory Defaults**—This option restores all BIOS settings to the factory default. This option is useful if the controller exhibits unpredictable behavior due to an incorrect or inappropriate BIOS setting. Notice that any nondefault settings such as boot order, passwords, and so on, are also restored to their factory defaults. The <F9> key can also be used to select this option.
- **Save As User Defaults**—This option saves a copy of the current BIOS settings as the User Defaults. This option is useful for preserving custom BIOS setup configurations.
- **Restore User Defaults**—This option restores all BIOS settings to the user defaults. This option is useful for restoring previously preserved custom BIOS setup configurations.
- **Boot Override**—This option lists all possible bootable devices and allows the user to override the **Boot Option Priorities** list for the current boot. If no changes have been made to the BIOS setup options, the system will continue booting to the selected device without first rebooting. If BIOS setup options have been changed and saved,

a reboot will be required and the boot override selection will not be valid.

BIOS Diagnostic Utilities

You can test the hard drive and memory of your controller with the included BIOS diagnostic utilities.

Accessing BIOS Diagnostic Utilities

Complete the following steps to start the BIOS Diagnostic Utility.

1. Power on or reboot your controller.
2. When the message **<F2> to run diagnostics** appears, press the **<F2>** key. The first diagnostic utility loads after a short delay.

Hard Drive Diagnostic Utility

The hard drive is tested first upon entry into the BIOS Diagnostic Utilities. A quick test is performed initially, and a more comprehensive test is performed afterwards. The user may abort and skip any test by pressing the **<Esc>** key at any time during that test. After both tests have finished or been skipped, the user is presented with the testing results. If both tests have succeeded or been skipped, **Press any key to continue** is displayed. In order to continue with testing, user interaction is required to press a key on the keyboard.



Note If either hard drive test fails, the controller is not permitted to boot, and the user is instructed to turn off the controller and replace the hard drive.

Memory Diagnostic Utility

The memory diagnostic utility is started immediately after the user presses a key to exit the hard drive diagnostic utility. The user may abort and skip the memory test by pressing the **<Esc>** key at any time during this test. After the memory utility has finished or been skipped, the user is presented with the testing result. If the memory test was successful or skipped, **Press any key to continue** is displayed. In order to continue to boot the controller, user interaction is required to press a key on the keyboard.



Note If the memory test fails, the controller is not permitted to boot, and the user is instructed to turn off the controller and replace the memory.

System CMOS

The NI PXIe-8820 contains memory backed up by a battery to store BIOS configuration information.

Complete the following steps to clear the CMOS contents:

1. Power off the chassis.
2. Remove the controller from the chassis.
3. Press the push-button switch, as shown in Figure 2-3.
4. Wait ten seconds.
5. Reinstall the controller in the chassis.

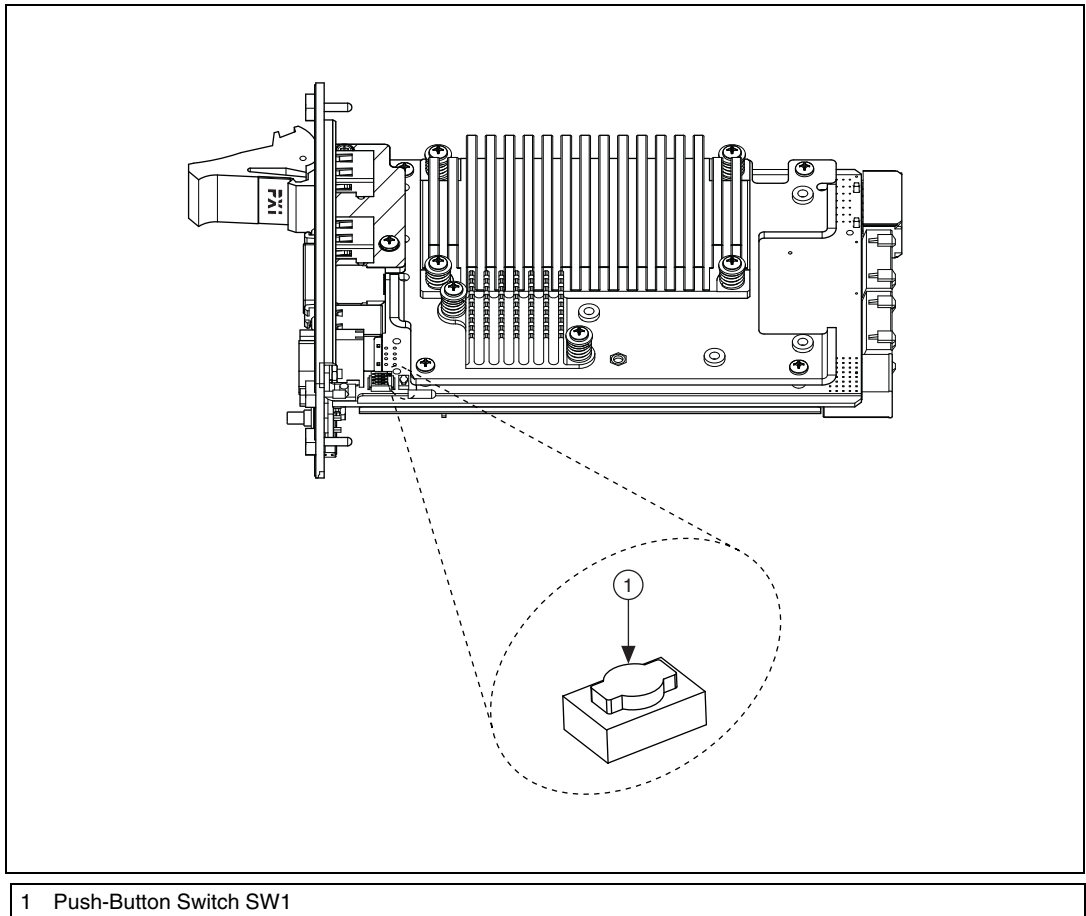

Figure 2-3. Clearing the CMOS Contents

LabVIEW RT Installation

This section explains software installation and switch configuration for LabVIEW RT on your PXI Express controller.

LabVIEW RT Software Installation

The following section describes the necessary steps to get your PXI Express embedded controller setup to run LabVIEW Real-Time. In this section you will configure the boot mode of the controller, verify or change IP settings, and install LabVIEW Real-Time software.

Complete the following steps to install the LabVIEW RT software.

1. Boot the NI PXI Express embedded controller into the real-time operating system. Refer to the [LabVIEW RT Configuration Switches](#) section or the [LabVIEW RT Setup Menu](#) section in this manual to configure the controller for booting into LabVIEW RT.

The PXI Express controller will automatically boot into LabVIEW RT Safe Mode when no software is installed. LabVIEW RT Safe Mode loads with the basic real-time operating system and will automatically attempt to connect to the network using DHCP. If DHCP is not available, it will then connect to the network with a link-local IP address.



Tip You can connect a monitor to the desktop PC to display startup messages such as the IP address and MAC address.

2. Open Measurement & Automation Explorer (MAX) on another computer in the same subnet and expand the **Remote Systems** branch. MAX lists the PXI Express controller as the model name of the controller followed by the MAC address (for example, **NI-PXIe-8820 00802f108562**).



Note The other computer must have LabVIEW, LabVIEW RT, and any desired drivers installed.



Tip Record the PXI Express controller MAC address, located on the side of the controller, for use in identifying the controller. The label also can be removed and placed on the front of the controller for easier access.

3. Click on the appropriate PXI Express controller entry to access the **Network Settings** tab in the right pane view.
4. (Optional) Enter a name for the RT target in the **Name** text box.

- (Optional) Set the network configuration options of the RT target in the **IP Settings** section and click the **Apply** button.

For information about configuring network settings, refer to the *Configuring Network Settings* book, accessible by browsing to **MAX Remote Systems Help»LabVIEW Real-Time Target Configuration»Configuring Network Settings** from the **Contents** tab of *MAX Help*.



Note When any IP or identification settings are changed, you will be prompted to reboot the controller for the changes to take effect. Click **Yes** to automatically reboot the RT target. You may also reboot the controller by right-clicking on the target name under **Remote Systems** and selecting **Reboot**.

After rebooting the PXI Express controller it will appear in the **Remote Systems** category with the assigned name.

- Expand the PXI Express controller view in the **Remote Systems** branch and select **Software**.
- Click the **Add/Remove Software** button in the toolbar to launch the LabVIEW Real-Time Software Wizard.
- Install the LabVIEW Real-Time software and device drivers that you require on the RT target. Refer to the NI Web site at ni.com/info and enter the Info Code `etspc` for the latest information about supported software.

After installation of the software the controller will automatically reboot and you will now be able to program it using LabVIEW Real-Time.



Note Refer to the *RT Getting Started Guide* available on your host computer for more information about setting up your RT target.

LabVIEW RT Configuration Switches

Use the LabVIEW RT configuration switches to configure LabVIEW RT if it is installed on the controller. If you are not using LabVIEW RT, these switches should remain in the OFF position. The controller reads these switches only after a system reset.

The NI PXIe-8820 controller includes the following LabVIEW RT configuration switches:

- Switch 1—**Boot LabVIEW RT**: Set this switch to ON to boot LabVIEW RT.

- Switch 2—**Boot Safe Mode**: Set this switch to ON to boot LabVIEW RT into safe mode to reconfigure TCP/IP settings and to download or update software from a host computer. This switch overrides the behavior of Switch 1. Booting the controller into safe mode does not start the embedded LabVIEW RT engine. After changing the settings or software, reboot the controller with this switch OFF to resume normal operation.
- Switch 3—**Disable Startup VI**: Set this switch to ON to prevent VIs from automatically running at startup if the controller becomes inaccessible because of a startup VI.
- Switch 4—**Reset IP Address**: Set this switch to ON to reset the IP address and other TCP/IP settings to their factory defaults. Use this switch if moving the controller to a different subnet or if the current TCP/IP settings are valid.



Note By default, the target will automatically attempt to connect to the network using DHCP. If the target is unable to initiate a DHCP connection, the target connects to the network with a link-local IP address or 169.254.x.x.

Figure 2-4 shows the location of the LabVIEW RT configuration switches. The switches are shown in the OFF position.

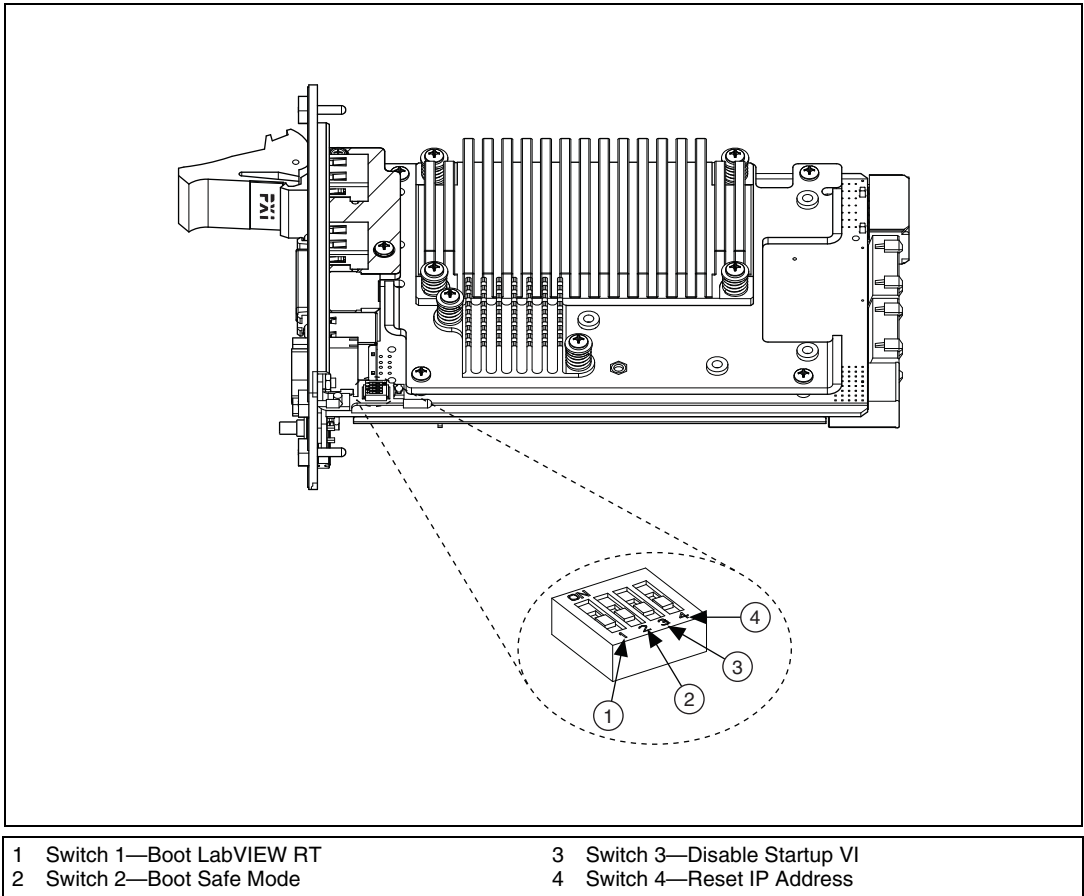

Figure 2-4. LabVIEW RT Configuration Switches

Drivers and Software

If you purchased a system that came preinstalled with Windows, your hard drive includes a directory called `images` in its root that contains software for the peripherals.

In the `images` directory, you will find a `drivers` directory. The `drivers` directory contains driver installers for the system peripherals. These files and directories are copied exactly from the manufacturer distribution disks, so the naming conventions vary from peripheral to peripheral.

PXI Express Features

PXI Express Trigger Connectivity

The SMB connector on the NI PXIe-8820 front panel can connect to or from any PXI Express backplane trigger line. Contact National Instruments for more information.

PXI Express Chassis Configuration

The PXI Express Platform Services software installed on your controller and available on the *National Instruments Driver DVD* or *PXI Platform Services DVD* included with your kit automatically identifies your PXI Express system components to generate a `pxiesys.ini` and `pxisys.ini` file. You can configure your entire PXI Express system through Measurement & Automation Explorer (MAX), included with your controller. MAX creates the `pxiesys.ini` and `pxisys.ini` file, which define your PXI Express system parameters. MAX also provides an interface to route and reserve triggers so dynamic routing, through drivers such as DAQmx, avoids double-driving and potentially damaging trigger lines. For more information about routing and reserving PXI Express triggers, refer to KnowledgeBase 3TJDOND8, *Using PXI Timing and Triggering Functionality*, at ni.com/support.

The configuration steps for single or multiple-chassis systems are the same.

PXI Express System Configuration

1. Launch Measurement & Automation Explorer (MAX).
2. In the **Configuration** tree, expand **Devices and Interfaces**.
3. In the **Devices and Interfaces** tree, expand **PXI System**. Your PXI Express chassis is already identified and appears in the **PXI System** tree.
4. For each unidentified PXI Express chassis in the **PXI System** tree, right-click on the chassis and select the appropriate chassis model through the **Identify As** submenu. Further expanding the **PXI System** branch shows all devices in the system that NI-VISA can recognize.

The PXI Express specification allows for many combinations of PXI Express chassis and system modules. To assist system integrators, PXI Express chassis and system module manufacturers must document their products' capabilities. PXI Express devices must provide a driver and/or `.ini` file for identification. For NI PXI Express chassis and controllers, these files are provided as part of the NI PXI Platform Services software included with your controller. System integrators, configuration utilities, and device drivers can use these `.ini` files.

The NI PXI Platform Services software uses the system module driver, chassis driver, and `chassis.ini` files to generate the PXI/PXI Express system description files (`pxisys.ini` and `pxiesys.ini`). Device drivers and other utility software read the `pxiesys.ini` and `pxisys.ini` files to obtain system information. For detailed information about initialization files, refer to the PXI Express specification at www.pxisa.org.

Upgrading RAM

You can change the amount of installed RAM on the NI PXIe-8820 by upgrading the SO-DIMM.

National Instruments offers the following SO-DIMM for use with the NI PXIe-8820 controller.

- Replacement 2 GB RAM (NI part number 782911-2048)
- Replacement/upgrade 4 GB RAM (NI part number 782911-4096)
- Replacement/upgrade 8 GB RAM (NI part number 781736-8192)



Notes National Instruments has tested and verified that the SO-DIMMs we sell work with the NI PXIe-8820. We recommend you purchase your SO-DIMM modules from National Instruments. Other off-the-shelf SO-DIMM modules are not guaranteed to work properly.

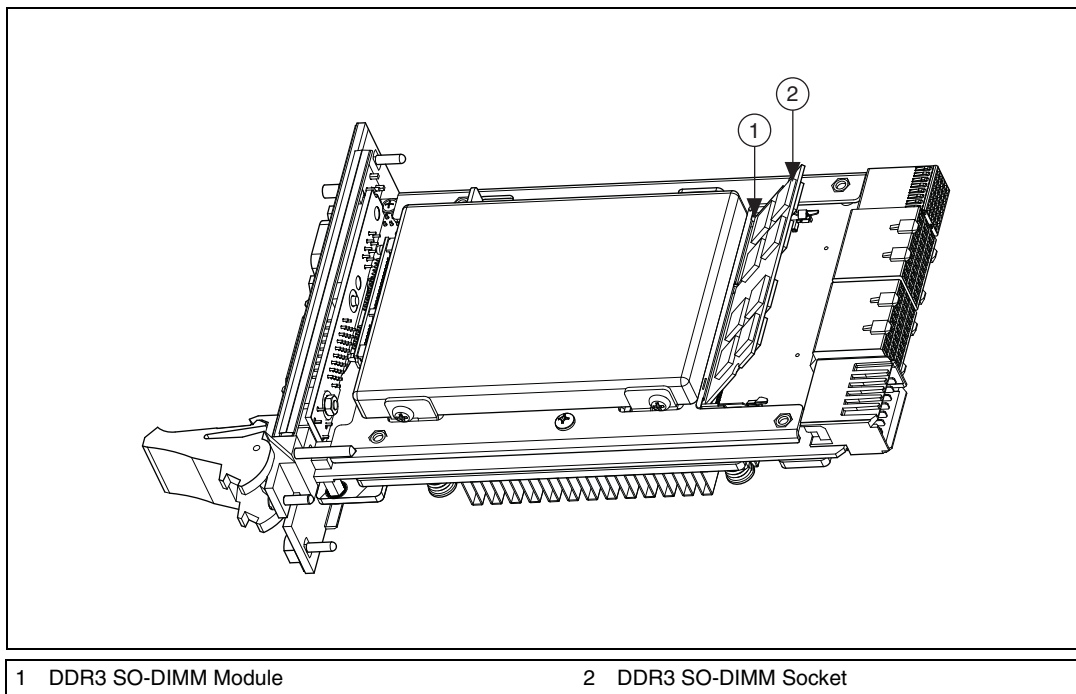

Figure 2-5. Installing a DDR3 SO-DIMM in an NI PXIe-8820 Controller

Hard Drive Recovery

NI PXIe-8820 controllers preinstalled with Windows include two methods of restoring the original factory condition of your hard drive. Hard drive-based recovery stores a factory backup on a separate portion of your hard drive allowing you to restore your controller without additional media. The NI PXIe-8820 controller also ships with an *OS Recovery CD* that allows you to reinstall your operating system onto your hard drive through an external USB CD/DVD-ROM. For more information on these tools, refer to KnowledgeBase 2ZKC02OK, *Hard Drive Recovery and OS Installation for PXI and VXI Controllers*, at ni.com/support.



Note The hard drive recovery hot key is <F4>. To access the hard drive-based recovery tool, press and hold <F4> when video first appears during the boot process.

If you want to recover your factory-installed operating system from a CD, you can use the included OS re-installation CD with an external USB CD/DVD-ROM drive. The re-installation CD does not reinstall the factory OS image; it installs only a base operating system. Boot the PXI Express controller using the OS re-installation CD to recover the OS. You also may need to reinstall other software after using the CD to recover the OS.



Note Recovering the OS erases the contents of your hard disk, including the factory hard drive recovery image. Back up the factory hard drive recovery image and any other files you want to keep.

Installing an OS

NI PXIe-8820 controllers may include a preinstalled OS. In some cases, you may want to install a different OS. When doing so, consider the following guidelines.

Installing from a USB CD/DVD-ROM

The NI PXIe-8820 supports the installation of Windows 7 from a USB CD/DVD-ROM. As an alternative to a USB CD/DVD-ROM drive, you can use an external SCSI CD-ROM with a PXI-SCSI adapter.



Note For additional assistance with installing or changing an operating system, refer to KnowledgeBase 2ZKC02OK, *Hard Drive Recovery and OS Installation for PXI and VXI Controllers*, at ni.com/support.

I/O Information

Front Panel Connectors

Table 3-1 lists various peripherals and their corresponding NI PXIe-8820 external connectors, bus interfaces, and functions.

Table 3-1. NI PXIe-8820 Peripherals Overview

Peripheral	External Connector	Description
Video	DisplayPort	Intel Extreme Graphics controller
Serial	COM1 (9-pin DSUB)	16550 RS-232 serial port
Ethernet	LAN (RJ45)	10/100/1000 Ethernet connection
Parallel	Parallel Port (36-pin champ)	IEEE 1284
USB	USB 4-pin Series A stacked receptacle	Hi-Speed USB
PXI trigger	Trigger (SMB)	Routing PXI triggers to or from the backplane trigger bus

Front Panel

Figure 3-1 shows the front panel layout and dimensions of the NI PXIe-8820. Dimensions are in inches (millimeters).

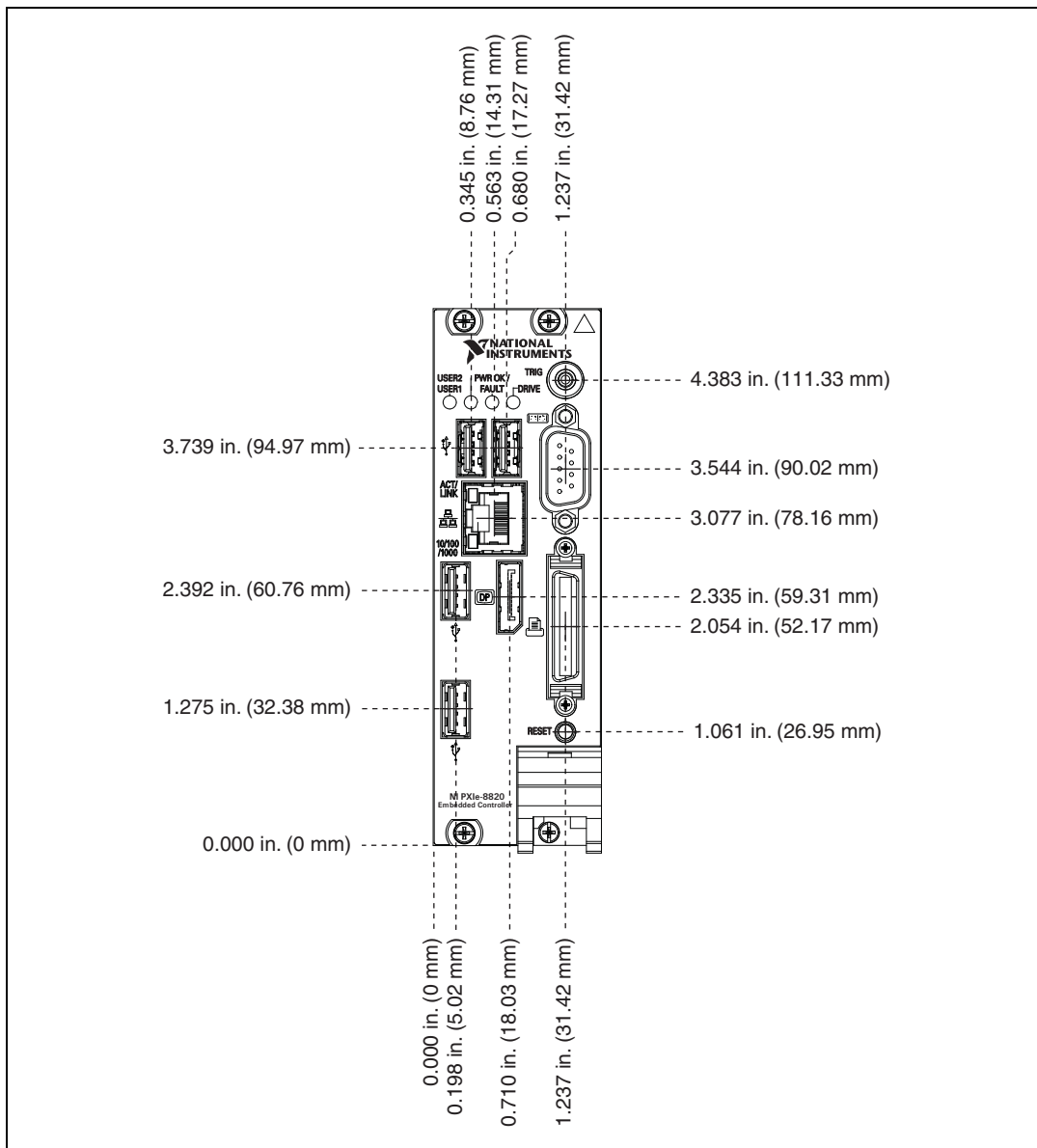

Figure 3-1. NI PXIe-8820 Front Panel Layout and Dimensions

DisplayPort

Figure 3-2 shows the location and pinouts for the DisplayPort connector on the NI PXIe-8820. Table 3-2 lists and describes the DisplayPort connector signals.

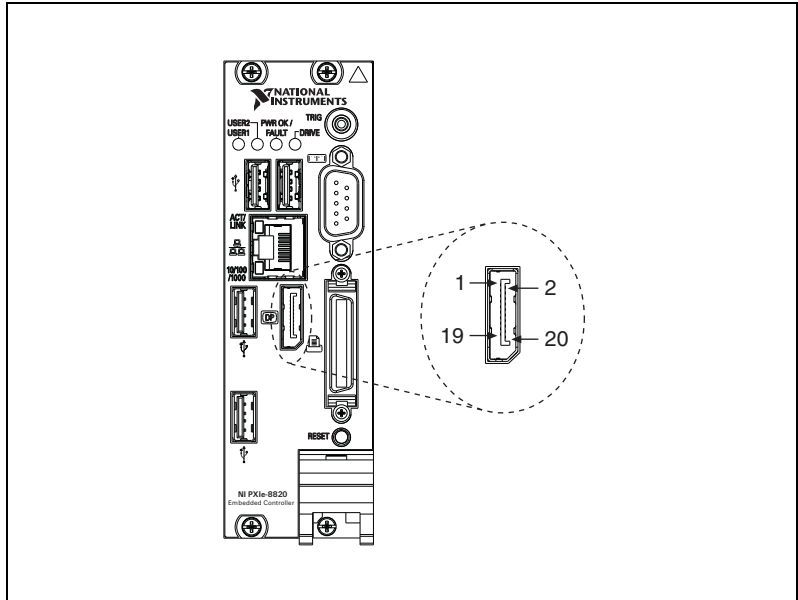

Figure 3-2. DisplayPort Connector Location and Pinout

Table 3-2. DisplayPort Connector Signals

Pin	Signal Name
1	ML_Lane0(p)
2	GND
3	ML_Lane0(n)
4	ML_Lane1(p)
5	GND
6	ML_Lane1(n)
7	ML_Lane2(p)
8	GND
9	ML_Lane2(n)

Table 3-2. DisplayPort Connector Signals (Continued)

Pin	Signal Name
10	ML_Lane3(p)
11	GND
12	ML_Lane3(n)
13	CONFIG1
14	CONFIG2
15	AUX CH (p)
16	GND
17	AUX CH (n)
18	Hot Plug Detect
19	Return
20	DP_PWR

COM1



Caution To ensure EMC compliance, limit serial cable length to no more than 30 meters.

Figure 3-3 shows the location and pinouts for the COM1 connector on the NI PXIe-8820. Table 3-3 lists and describes the COM1 connector signal.

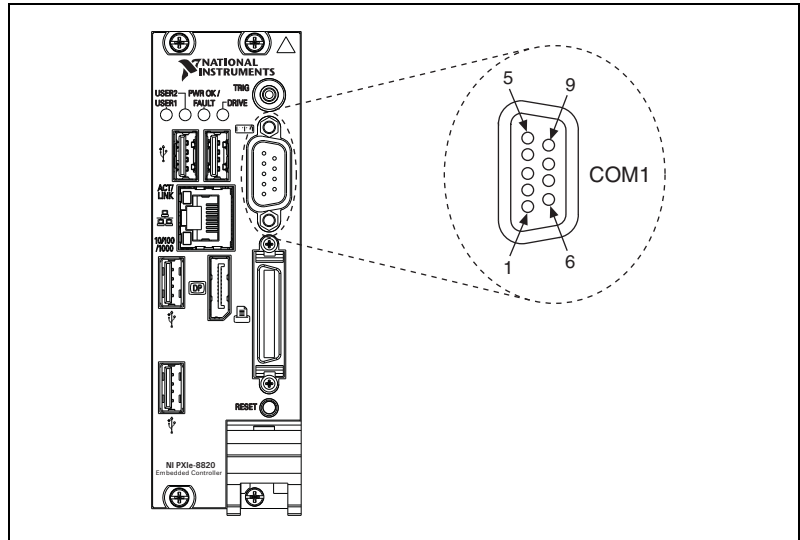

Figure 3-3. COM1 Connector Location and Pinout

Table 3-3. COM1 Connector Signals

Pin	Signal Name	Signal Description
1	DCD#	Data Carrier Detect
2	RXD#	Receive Data
3	TXD#	Transmit Data
4	DTR#	Data Terminal Ready
5	GND	Ground
6	DSR#	Data Set Ready
7	RTS#	Ready to Send
8	CTS#	Clear to Send
9	RI#	Ring Indicator

Note: The pound symbol (#) indicates an active low signal.

Ethernet

Figure 3-4 shows the location and pinouts for the Ethernet connector on the NI PXIe-8820. Table 3-4 lists and describes the Ethernet connector signals.



Note The Wake On LAN feature is only supported by Ethernet Port 1.

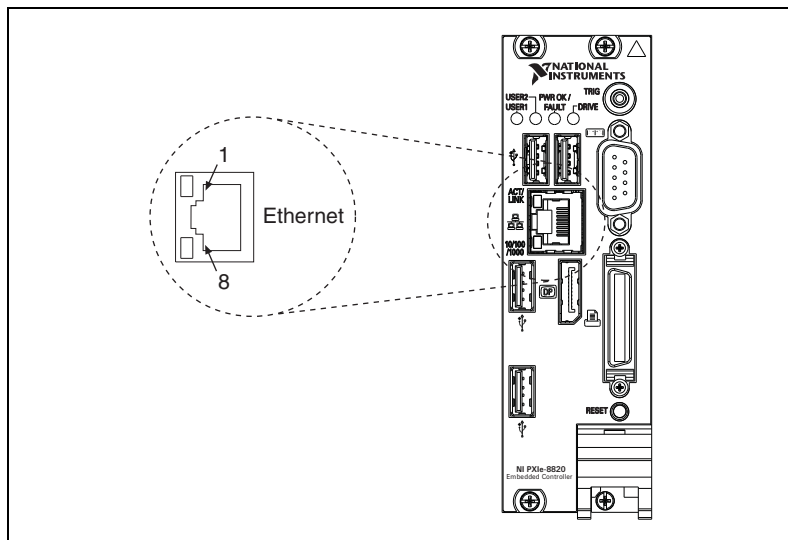

Figure 3-4. Ethernet Connector Location and Pinout

Table 3-4. Ethernet Connector Signals

Pin	Fast Ethernet	Gigabit Ethernet
1	TX+	TX_A+
2	TX-	TX_A-
3	RX+	RX_B+
4	NC	TX_C+
5	NC	TX_C-
6	RX-	RX_B-
7	NC	RX_D+
8	NC	RX_D-



Note The Ethernet controller can perform an automatic crossover, thus eliminating the need for crossover cables.

Table 3-5. 10/100/1000 LAN Connector LED States

LED	Color	LED State	Condition
Top	Green	Off	LAN link is not established.
		On (steady state)	LAN link is established.
		On (brighter and pulsing)	The controller is communicating with another computer on the LAN.
Bottom	Unlit	Off	10 Mbit/sec data rate is selected.
	Green	On	100 Mbit/sec data rate is selected.
	Amber	On	1000 Mbit/sec data rate is selected.

Parallel Port

Figure 3-5 shows the location and pinouts for the IEEE 1284 (parallel) connector on the NI PXIe-8820. Table 3-6 lists and describes the IEEE 1284 connector signals.

Parallel port adapter cables are available from National Instruments, part number 777169-01.

**Figure 3-5.** Parallel Port Connector Location and Pinout

Table 3-6. Parallel Port Connector Signals

Pin	Default Configuration (LPT)	
	Signal Name	Signal Description
1	BUSY	Device Busy
2	SLCT	Select
3	ACK#	Acknowledge
4	FAULT#(ERROR#)	Fault
5	PAPEREND	Paper End
6	PD0	Data Bit 0
7	PD1	Data Bit 1
8	PD 2	Data Bit 2
9	PD3	Data Bit 3
10	PD4	Data Bit 4
11	PD5	Data Bit 5
12	PD6	Data Bit 6
13	PD7	Data Bit 7
14	INIT#	Initialize Printer
15	STROBE#	Strobe
16	SLCTIN#	Select Input
17	AUTOFD#	Auto Line Feed
18	+5V	+5 V
19-35	GND	Ground
36	NC	Not Connected

Note: The pound symbol (#) indicates an active low signal.

Universal Serial Bus

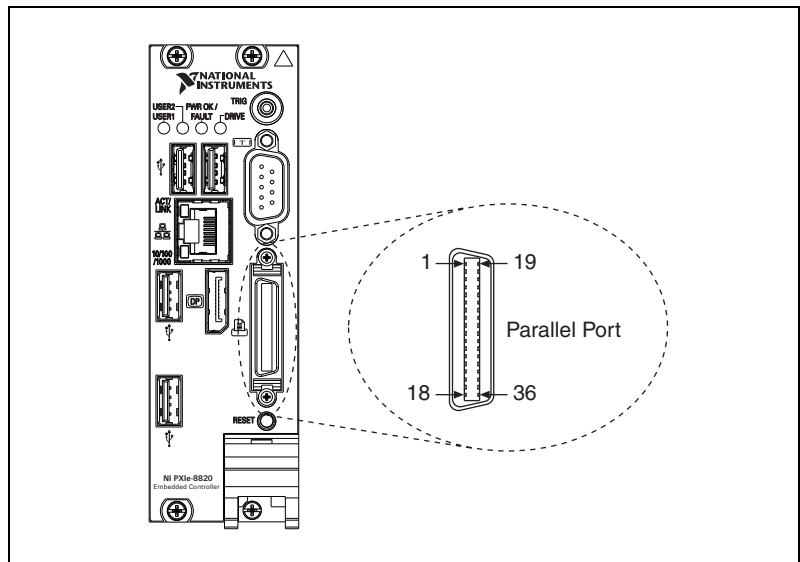
Figure 3-6 shows the location and pinouts for the Universal Serial Bus (USB) connector on the NI PXIe-8820. Each controller has four USB ports on the front panel. Table 3-7 lists and describes the USB connector signals.

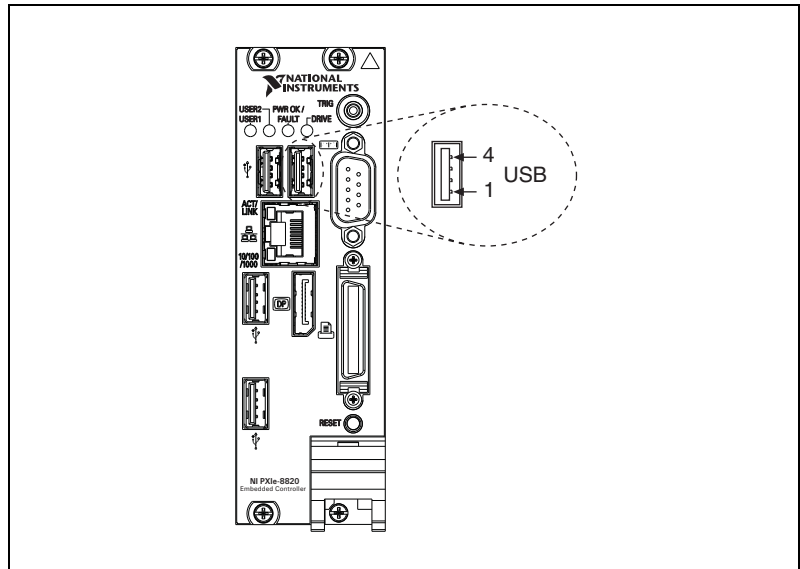

Figure 3-6. USB Connector Location and Pinout

Table 3-7. USB Connector Signals

Pin	Signal Name	Signal Description
1	VCC	Cable Power (+5 V)
2	-Data	USB Data -
3	+Data	USB Data +
4	GND	Ground



Caution To ensure the specified EMC performance, install a snap-on ferrite (National Instruments part number 711849-01) in accordance with the product installation instructions.

Install a noise-suppression ferrite (included in your shipping kit) around all attached external USB cables to ensure that your device meets all EMC standards applicable to your country. Install the ferrite so that each USB cable loops through the ferrite as shown in Figure 3-7. The ferrite should be installed so that it is approximately 50–75 mm (2-3 in.)

from the end of the cable that plugs into the controller. The ferrite should accommodate from 2-4 USB cables depending on cable diameter.

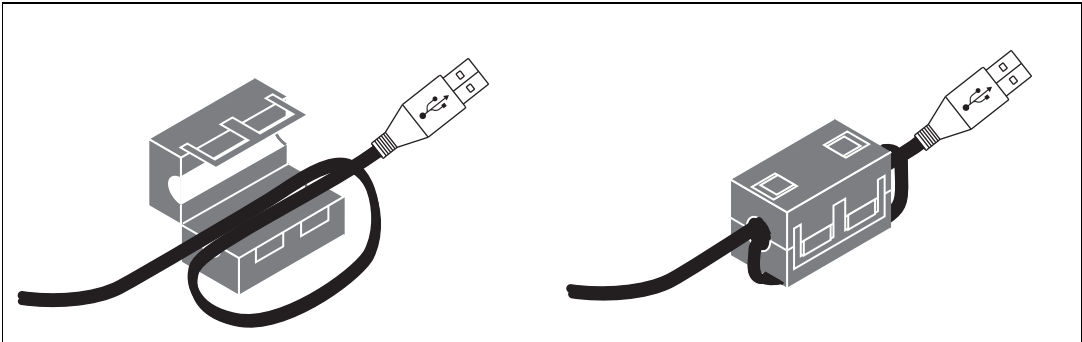

Figure 3-7. Installing a Ferrite on a Single USB Cable

Trigger

The TRIG connector is the software-controlled trigger connection for routing PXI triggers to or from the backplane trigger bus.

Figure 3-8 shows the TRIG connector location on the NI PXIe-8820. Table 3-8 lists and describes the trigger connector signals.

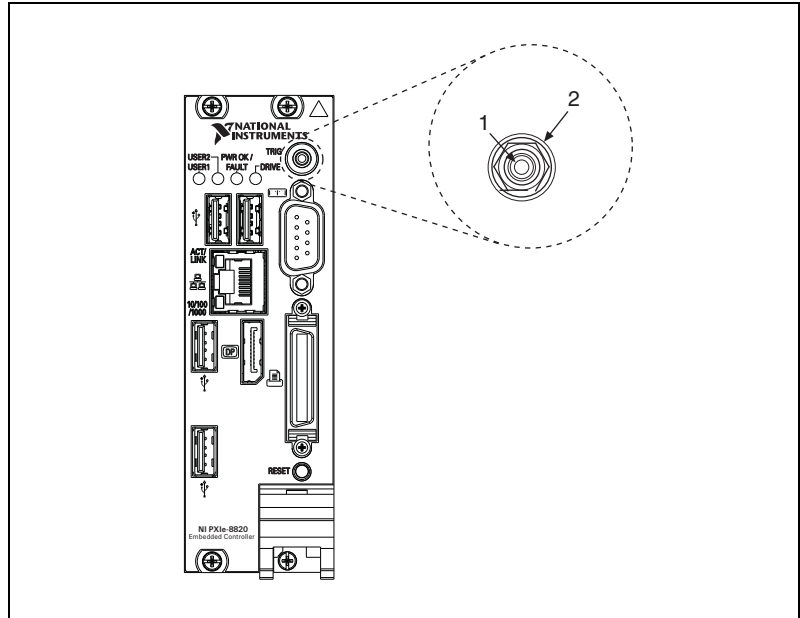

Figure 3-8. TRIG Connector Location and Pinout

Table 3-8. TRIG Connector Signals

Pin	Signal Name	Signal Description
1	TRIG	Trigger
2 (Shield)	GND	Ground

Front Panel Features

The NI PXIe-8820 has the following front-panel features:

- A controller reset pushbutton (press the button to generate a reset to the controller)
- Two front panel LEDs that show PC status
 - The **DRIVE** LED indicates when an access to the internal hard disk is occurring.
 - The **PWR OK/FAULT** LED indicates the status of the controller. The LED will indicate one of the following states:
 - Green ON steady—PXI Express and onboard power is on and within regulation limits.
 - Green BLINKING—One of the onboard power supplies is operating outside of the normal limits or the system power supply is out of regulation.
 - OFF—The controller is powered off.
 - Red BLINKING—The controller detected a power rail fault when trying to boot.
 - The **USER1** LED is a bi-color green/yellow LED. You can define the USER1 LED to meet the needs of your LabVIEW application.
 - The **USER2** LED is a bi-color green/yellow LED. You can define the USER2 LED to meet the needs of your LabVIEW application.

Data Storage

The NI PXIe-8820 has the following data storage features:

- 2.5 in. SATA notebook internal hard drive
- USB storage support—USB CD/DVD-ROM, mass storage device, or floppy drive

Common Configuration Questions

This chapter answers common configuration questions you may have when using a NI PXIe-8820 embedded controller.

General Questions

What do the LEDs on the NI PXIe-8820 front panel mean?

Refer to the LED status descriptions in the *Front Panel Features* section of Chapter 3, *I/O Information*.

After shutting down my NI PXIe-8820 controller, the Ethernet LEDs continue to blink. Is it safe to remove my controller or disconnect power?

The NI PXIe-8820 controller Ethernet device remains powered even after shutdown to support the Wake On LAN feature. It is safe to remove your controller or disconnect power.



Note The Wake On LAN feature is supported by Ethernet Port 1.

How do I check the configuration of the memory, hard drive, time/date, and so on?

You can view these parameters in the BIOS setup. To enter the BIOS setup, reboot the NI PXIe-8820 and press <Delete> during the memory tests. Refer to the *Accessing BIOS Setup Utility* section of Chapter 2, *Installation and Configuration*, for more information.

Can I use the internal Serial ATA drive and an external hard drive at the same time?

Yes.

Boot Options

What devices can I boot from?

The NI PXIe-8820 can boot from the following devices:

- The internal Serial ATA hard drive
- An external SCSI hard drive or CD/DVD-ROM if an SCSI adapter, such as the PXI-8214, is used
- A network PXE server on the same subnet
- An external USB mass storage device such as a USB hard drive, USB CD/DVD-ROM, or USB key
- An external USB floppy drive
- Most PCI or PCIe-based devices that provide an Option ROM



Note There are some limitations when booting from a USB device. Windows 7 can be installed from a USB CD/DVD-ROM, but earlier versions of Windows cannot. The NI PXIe-8820 BIOS configures the USB devices so that they will work in a DOS environment.

How do I configure the controller to boot from these devices?

There are two methods.

- Enter Setup and select the **Boot** menu. You will see a list of all bootable devices, ordered by device type. You can set the boot order using <+> and <->. Set the order by device type and set the order for the devices listed within the device type.
- To boot from a different device without changing the boot order in the BIOS, press <F10> continuously while booting. After the BIOS completes the POST and just before the controller boots the OS, the **Boot** menu is displayed. You can select the device type you want to boot from.

Cables and Connections

How do I plug both a PS/2 mouse and PS/2 keyboard into the controller?

The NI PXIe-8820 has no PS/2 connector, and you need to use a USB Y-splitter cable as shown in Figure 4-1, or a similar device, to connect both a PS/2 mouse and PS/2 keyboard. National Instruments part number 778713-01 is such a cable and is available through the online catalog at ni.com/products.

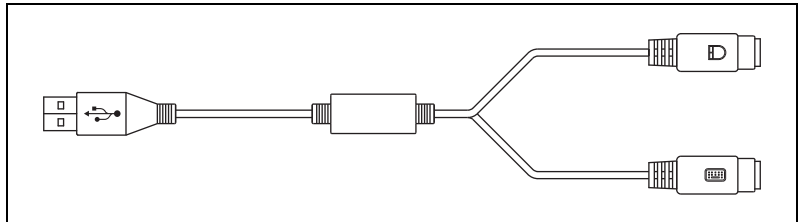

Figure 4-1. Y-Splitter Cable

What if I don't have a Y-splitter cable? Can I still use a mouse and keyboard?

If you do not have a Y-splitter cable, plug a USB keyboard into any USB connector. You can also plug a USB mouse into any USB connector.

How do I connect a standard 25-pin LPT cable to the NI PXIe-8820?

The NI PXIe-8820 uses a type C LPT connector. Most parallel port devices use a type A connector. To use a device with a standard type A LPT connector, you need to use a type C-to-type A LPT adapter. Parallel port adapter cables, part number 777169-01, are available through the online catalog at ni.com/products.

How do I connect a VGA monitor to the NI PXIe-8820?

A DisplayPort-to-VGA adapter (part number 782271-01) is included with your kit. You can use this adapter to connect a VGA monitor to a DisplayPort connector.

Software Driver Installation

How do I install or reinstall the video driver?

Refer to KnowledgeBase 3H3COSD8, *What Peripheral Drivers Should I Use with My PXI or VXI Controller?*, at ni.com/support.

How do I install or reinstall the Ethernet driver?

Refer to KnowledgeBase 3H3COSD8, *What Peripheral Drivers Should I Use with My PXI or VXI Controller?*, at ni.com/support.

How do I install software from a CD?

The compact size of the NI PXIe-8820 does not allow for an integrated USB CD/DVD-ROM drive. You have the following options:

- **USB CD/DVD-ROM**—You can install from a USB CD/DVD-ROM using a bootable installation CD.
- **SCSI CD-ROM**—Other types of CD-ROM drives are available. Check with the vendor to make sure Windows 7 supports the drive.
- **Mapped network drive**—You can use the Ethernet to connect to another computer. If you share the USB CD/DVD-ROM drive on the other computer, you can map the shared USB CD/DVD-ROM drive to a drive letter on the NI PXIe-8820.

A USB CD/DVD-ROM drive is available from National Instruments, part number 778492-01.

Upgrade Information

How do I upgrade system memory?

You can change the amount of installed RAM on the NI PXIe-8820 by upgrading the SO-DIMM.

To upgrade the RAM, remove the NI PXIe-8820 from the PXI chassis.

National Instruments offers the following types of SO-DIMMs for use with the NI PXIe-8820 controller.

- Replacement 2 GB RAM (NI part number 782911-2048)
- Replacement/upgrade 4 GB RAM (NI part number 782911-4096)
- Replacement/upgrade 8 GB RAM (NI part number 781736-8192)



Note National Instruments has conducted thermal testing as well as mechanical shock and vibration testing, and has verified that the SO-DIMMs we sell work with the NI PXIe-8820. We recommend you purchase your SO-DIMM modules from National Instruments. Other off-the-shelf SO-DIMM modules are not guaranteed to work properly.

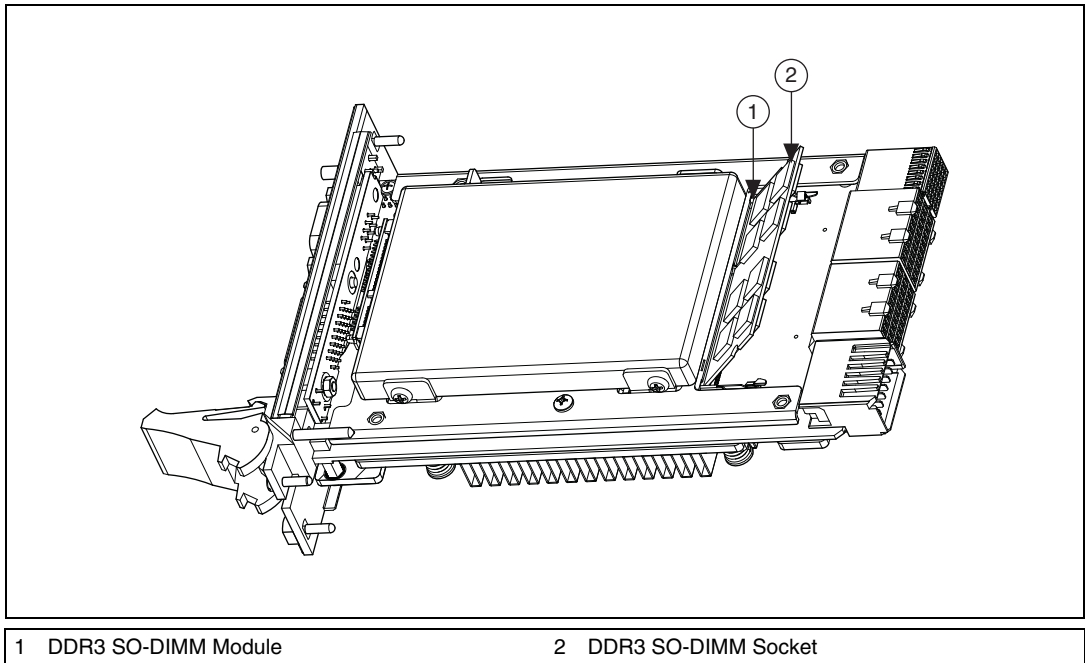

Figure 4-2. Installing a DDR3 SO-DIMM in an NI PXIe-8820 Controller

How do I flash a new BIOS?

You can download the new BIOS from [ftp.ni.com/support/pxi](ftp://ni.com/support/pxi). For more information, refer to KnowledgeBase **2GIGKD0Z**, *Determining and Upgrading PXI and VXI Embedded Controller BIOS Versions*.

Where do I get the latest software drivers?

The latest National Instruments software is available from ni.com/downloads. For peripheral drivers, refer to KnowledgeBase **3H3COSD8**, *What Peripheral Drivers Should I Use with My PXI or VXI Controller?*, at ni.com.

PXI Express Configuration

How do I use the SMB trigger on the front panel?

For details, refer to the [PXI Express Features](#) section of Chapter 2, [Installation and Configuration](#).

Troubleshooting

This chapter answers common troubleshooting questions you may have when using the NI PXIe-8820 embedded computer.

What if the NI PXIe-8820 does not boot?

Several problems can cause a controller not to boot. Here are some things to look for and possible solutions.

Things to Notice:

- Which LEDs come on? The **Power OK** LED should stay lit. The **Drive** LED should blink during boot as the disk is accessed.
- What appears on the display? Does it hang at some particular point (BIOS, Operating System, and so on.)? If nothing appears on the screen, try a different monitor. Does your monitor work with a different PC? If it hangs, note the last screen output that you saw for reference when consulting National Instruments technical support.
- What has changed about the system? Did you recently move the system? Was there electrical storm activity? Did you recently add a new module, memory chip, or piece of software?
- Refer to your chassis user manual for additional troubleshooting steps.

Things to Try:

- Make sure the chassis is plugged in to a working power source.
- Check any fuses or circuit breakers in the chassis or other power supply (possibly a UPS).
- Make sure the controller module is firmly seated in the chassis.
- Remove all other modules from the chassis.
- Remove any nonessential cables or devices.
- Try the controller in a different chassis.
- Try a similar controller in this same chassis.
- Clear the CMOS. (Refer to the [System CMOS](#) section of Chapter 2, *Installation and Configuration*.)

- Recover the hard drive on the controller. (Refer to the [Hard Drive Recovery](#) section of Chapter 2, *Installation and Configuration*.)
- Make sure the RAM is properly seated.

My controller boots fine until I get to Windows, at which point I cannot read the screen. This may include garbled output, white screen, black screen, or an out of synch message from the monitor.

This problem usually results from having the video card output set past the limits of the monitor. You will need to boot Windows in Safe Mode. To do this, reboot the controller. As Windows begins to boot, hold down <F8>. You should now be able to reset the video driver to lower settings. Try setting the resolution to 640 × 480 and the refresh rate to 60 Hz. Once you reboot, you can raise these values again, using the test option in Windows. These settings are accessible through the **Advanced** tab of the **Display** item in the **Control Panel**. Alternately, you can try a different monitor, preferably a newer and larger one.

My system boots fine as long as a particular module is not in my chassis.

The most common cause of this is a damaged module. Try the module in a different chassis or with a different controller. Also, remove any external cables or terminal blocks connected to the system. If the module does not work in these cases, it is likely damaged. Contact the module manufacturer for further troubleshooting.

Refer to the KnowledgeBase or product manuals section at [ni.com](#) for more information specific to the chassis and controller with which you are having difficulties.

My CMOS is corrupted. How do I set it back to default?

1. Enter the BIOS setup program as described in the [Accessing BIOS Setup Utility](#) section of Chapter 2, *Installation and Configuration*.
2. Check the battery utility.
3. Press <F9> to load BIOS defaults.
4. Answer **Y** (Yes) to the verification prompt.
5. Select **Save and Exit Setup**.

As an alternative method, complete the following steps:

1. Power off the chassis.
2. Remove the controller from the chassis.

3. Press and hold down the pushbutton switch SW1 for 2-3 seconds. The SW1 switch location is shown in Figure 5-1.
4. Reinstall the controller in the chassis.

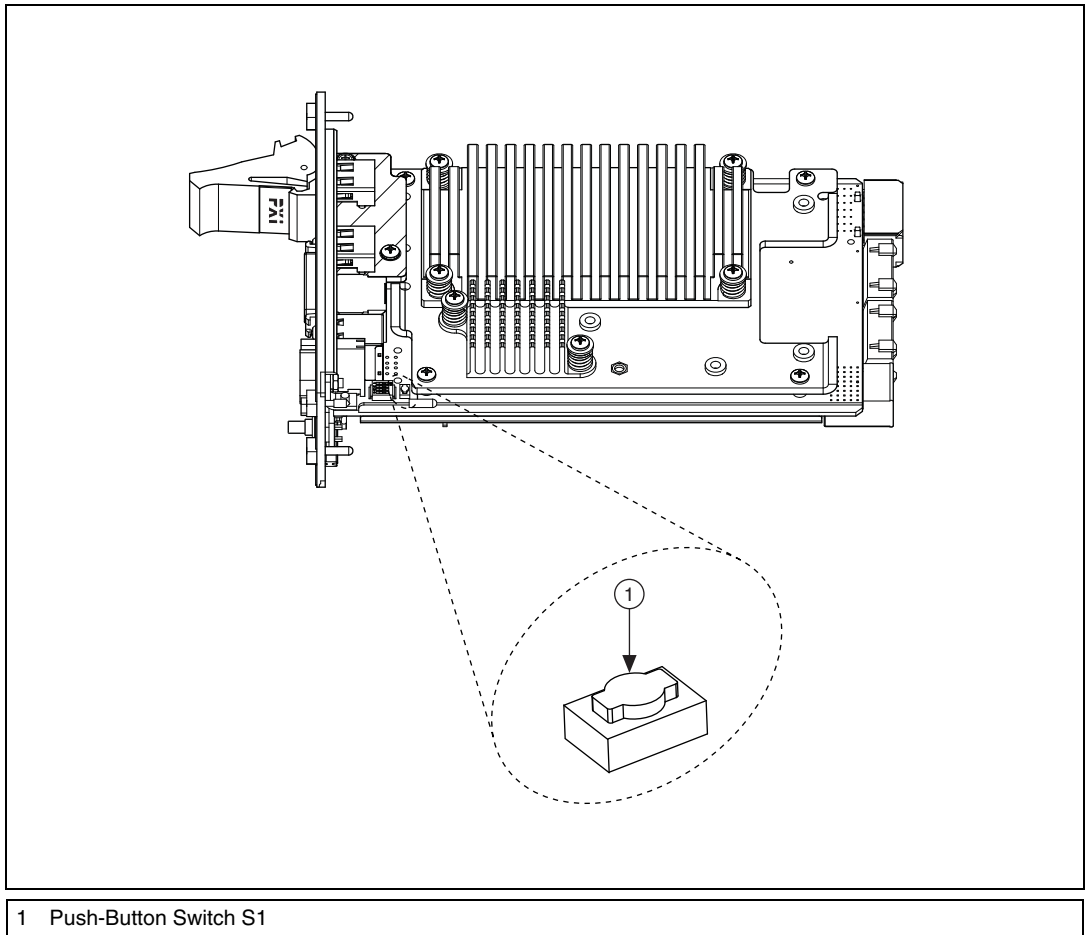

Figure 5-1. Clearing the CMOS Contents

Specifications

This appendix lists the electrical, mechanical, and environmental specifications of the NI PXIe-8820 embedded controller.

Features

NI PXIe-8820	
CPU	Intel® Celeron® 1020E (2.20 GHz dual core processor)
On-die L2 cache	2 MB
Single-Channel DDR3 RAM, PC3 10600	2 GB Standard 8 GB Maximum
Hard Drive	250 GB Serial ATA, minimum*
Ethernet	10/100/1000 BaseT
PXI Express 4 Link Configuration	x1, x1, x1, x1
PXI Express 2 Link Configuration	x1, x1
Serial Ports (RS-232)	Yes (1)
Parallel Port	Yes (1)
Hi-Speed USB (2.0) Ports	Yes (4)
PS/2 Keyboard/Mouse Connector	No
PXI Trigger Bus Input/Output	Yes
Installed Operating System	Windows 7 Professional
* Controllers configured for LabVIEW RT provide a 80 GB (minimum) SATA hard drive.	

Electrical

Voltage (V)	Current (Amps)	
	Typical	Maximum
+3.3 V	1.9 A	2.4 A
+5 V	0.7 A	1.9 A
+12 V	2.3 A	2.5 A
-12 V	0 A	0 A
+5 V _{Aux}	0.55 A	0.66 A

Note: Does not include any attached USB devices or ExpressCard.

Physical

Board dimensions	2-slot 3U PXI Express module
Slot requirements	One system slot plus one controller expansion slot
Compatibility	Fully compatible with <i>PXI Express Specification 1.0</i>
Weight	0.85 kg (1.87 lb) typical

Environment

Maximum altitude.....	2,000 m (800 mbar) (at 25 °C ambient temperature)
Pollution Degree	2
Indoor use only.	



Caution Clean the NI PXIe-8820 with a soft nonmetallic brush. Make sure that the device is completely dry and free from contaminants before returning it to service.

Operating Environment

Ambient temperature range.....	5 to 50 °C (Tested in accordance with IEC-60068-2-1 and IEC-60068-2-2. Meets MIL-PRF-28800F Class 3 high temperature limit.)
Relative humidity range	10% to 90%, noncondensing (Tested in accordance with IEC-60068-2-56.)



Caution The operating temperature must not be exceeded, even when used in a chassis with a higher temperature range.

Storage Environment

Ambient temperature range.....	-40 to 65 °C (Tested in accordance with IEC-60068-2-1 and IEC-60068-2-2. Meets MIL-PRF-28800F Class 3 low temperature limit.)
Relative humidity range	5% to 95%, noncondensing (Tested in accordance with IEC-60068-2-56.)

Shock and Vibration

Operating Shock.....	30 g peak, half-sine, 11 ms pulse (Tested in accordance with IEC-60068-2-27. Meets MIL-PRF-28800F Class 2 limits.)
----------------------	---

Random Vibration

Operating	5 to 500 Hz, 0.3 g _{rms} (with solid-state hard drive)
Nonoperating	5 to 500 Hz, 2.4 g _{rms} (Tested in accordance with IEC-60068-2-64. Nonoperating test profile exceeds the requirements of MIL-PRF-28800F, Class 3.)



Note Specifications are subject to change without notice.

Safety

This product is designed to meet the requirements of the following standards of safety for electrical equipment for measurement, control, and laboratory use:

- IEC 61010-1, EN 61010-1
- UL 61010-1, CSA 61010-1



Note For UL and other safety certifications, refer to the product label or the [Online Product Certification](#) section.

Electromagnetic Compatibility

This product meets the requirements of the following EMC standards for electrical equipment for measurement, control, and laboratory use:

- EN 61326-1 (IEC 61326-1): Class A emissions; Basic immunity
- EN 55011 (CISPR 11): Group 1, Class A emissions
- EN 55022 (CISPR 22): Class A emissions
- EN 55024 (CISPR 24): Immunity
- AS/NZS CISPR 11: Group 1, Class A emissions
- AS/NZS CISPR 22: Class A emissions
- FCC 47 CFR Part 15B: Class A emissions
- ICES-001: Class A emissions



Note In the United States (per FCC 47 CFR), Class A equipment is intended for use in commercial, light-industrial, and heavy-industrial locations. In Europe, Canada, Australia and New Zealand (per CISPR 11) Class A equipment is intended for use only in heavy-industrial locations.



Note Group 1 equipment (per CISPR 11) is any industrial, scientific, or medical equipment that does not intentionally generate radio frequency energy for the treatment of material or inspection/analysis purposes.



Note For the standards applied to assess the EMC of this product, refer to the [Online Product Certification](#) section.

CE Compliance

This product meets the essential requirements of applicable European Directives as follows:

- 2006/95/EC; Low-Voltage Directive (safety)
- 2004/108/EC; Electromagnetic Compatibility Directive (EMC)

Online Product Certification

Refer to the product Declaration of Conformity (DoC) for additional regulatory compliance information. To obtain product certifications and the DoC for this product, visit ni.com/certification, search by model number or product line, and click the appropriate link in the Certification column.

Environmental Management

NI is committed to designing and manufacturing products in an environmentally responsible manner. NI recognizes that eliminating certain hazardous substances from our products is beneficial to the environment and to NI customers.

For additional environmental information, refer to the *Minimize Our Environmental Impact* web page at ni.com/environment. This page contains the environmental regulations and directives with which NI complies, as well as other environmental information not included in this document.

Waste Electrical and Electronic Equipment (WEEE)



EU Customers At the end of the product life cycle, all products *must* be sent to a WEEE recycling center. For more information about WEEE recycling centers, National Instruments WEEE initiatives, and compliance with WEEE Directive 2002/96/EC on Waste and Electronic Equipment, visit ni.com/environment/weee.

Battery Replacement and Disposal



Battery Directive This device contains a long-life coin cell battery. If you need to replace it, use the Return Material Authorization (RMA) process or contact an authorized National Instruments service representative. For more information about compliance with the EU Battery Directive 2006/66/EC about Batteries and Accumulators and Waste Batteries and Accumulators, visit ni.com/environment/batterydirective.

电子信息产品污染控制管理办法（中国 RoHS）



中国客户 National Instruments 符合中国电子信息产品中限制使用某些有害物质指令 (RoHS)。关于 National Instruments 中国 RoHS 合规性信息，请登录 ni.com/environment/rohs_china。(For information about China RoHS compliance, go to ni.com/environment/rohs_china.)

Technical Support and Professional Services

Log in to your National Instruments ni.com User Profile to get personalized access to your services. Visit the following sections of ni.com for technical support and professional services:

- **Support**—Technical support at ni.com/support includes the following resources:
 - **Self-Help Technical Resources**—For answers and solutions, visit ni.com/support for software drivers and updates, a searchable KnowledgeBase, product manuals, step-by-step troubleshooting wizards, thousands of example programs, tutorials, application notes, instrument drivers, and so on. Registered users also receive access to the NI Discussion Forums at ni.com/forums. NI Applications Engineers make sure every question submitted online receives an answer.
 - **Standard Service Program Membership**—This program entitles members to direct access to NI Applications Engineers via phone and email for one-to-one technical support, as well as exclusive access to self-paced online training modules at ni.com/self-paced-training. All customers automatically receive a one-year membership in the Standard Service Program (SSP) with the purchase of most software products and bundles including NI Developer Suite. NI also offers flexible extended contract options that guarantee your SSP benefits are available without interruption for as long as you need them. Visit ni.com/ssp for more information.

For information about other technical support options in your area, visit ni.com/services, or contact your local office at ni.com/contact.

- **Training and Certification**—Visit ni.com/training for training and certification program information. You can also register for instructor-led, hands-on courses at locations around the world.
- **System Integration**—If you have time constraints, limited in-house technical resources, or other project challenges, National Instruments

Alliance Partner members can help. To learn more, call your local NI office or visit ni.com/alliance.

- **Declaration of Conformity (DoC)**—A DoC is our claim of compliance with the Council of the European Communities using the manufacturer’s declaration of conformity. This system affords the user protection for electromagnetic compatibility (EMC) and product safety. You can obtain the DoC for your product by visiting ni.com/certification.
- **Calibration Certificate**—If your product supports calibration, you can obtain the calibration certificate for your product at ni.com/calibration.

You also can visit the Worldwide Offices section of ni.com/niglobal to access the branch office Web sites, which provide up-to-date contact information, support phone numbers, email addresses, and current events.

Glossary

Symbol	Prefix	Value
n	nano	10^{-9}
μ	micro	10^{-6}
m	milli	10^{-3}
k	kilo	10^3
M	mega	10^6
G	giga	10^9
T	tera	10^{12}

Symbols

° Degrees.

Ω Ohms.

% Percent.

A

A Amperes.

AC Alternating Current.

B

B Bytes.

backplane An assembly, typically a printed circuit board, with connectors and signal paths that bus the connector pins.

BIOS Basic Input/Output System—BIOS functions are the fundamental level of any PC or compatible computer. BIOS functions embody the basic operations needed for successful use of the computer's hardware resources.

C

C	Celsius.
cache	Small portion of high-speed memory used for temporary storage of frequently used data.
CMOS	Complementary Metal Oxide Semiconductor—A process used in making chips.
CompactPCI Express	An adaptation of the PCI specification for industrial and/or embedded applications that require a more robust mechanical form factor than desktop PCI. CompactPCI Express provides a standard form factor for those applications requiring the high performance of PCI as well as the small size and ruggedness of a rack-mount system.

D

DC	Direct Current.
DDR	Double Data Rate.
DMA	Direct Memory Access—A method by which data is transferred between devices and internal memory without intervention of the central processing unit.

E

ECP	Extended Capabilities Parallel.
EEPROM	Electrically Erasable Programmable Read Only Memory.
EMC	Electromagnetic Compatibility.
EMI	Electromagnetic interference.
EPP	Enhanced Parallel Port.
expansion ROM	An onboard EEPROM that may contain device-specific initialization and system boot functionality.

F

FCC Federal Communications Commission.

G

g

1. Grams.
2. A measure of acceleration equal to 9.8 m/s^2 .

GPIB General Purpose Interface Bus (IEEE 488).

g_{rms} A measure of random vibration—The root mean square of acceleration levels in a random vibration test profile.

H

Hz Hertz—Cycles per second.

I

I/O Input/Output—The techniques, media, and devices used to achieve communication between machines and users.

IDE Integrated Drive Electronics—Hard disk and built-in controller.

IEEE Institute of Electrical and Electronics Engineers.

in. Inches.

instrument driver A set of routines designed to control a specific instrument or family of instruments, and any necessary related files for LabWindows/CVI or LabVIEW.

interrupt A means for a device to request service from another device.

interrupt level The relative priority at which a device can interrupt.

IRQ# Interrupt signal.

ISA Industry Standard Architecture—The original PC bus architecture, specifically the 16-bit AT bus.

K

KB Kilobytes of memory.

L

LAN Local Area Network—Communications network that serves users within a confined geographical area. It is made up of servers, workstations, a network operating system, and a communications link.

LED Light-emitting diode.

M

m Meters.

master A functional part of a PXI device that initiates data transfers on the PXI backplane. A transfer can be either a read or a write.

MB Megabytes of memory.

MTBF Mean time between failure.

N

NI-488 or NI-488.2 The National Instruments software for GPIB systems.

NI-DAQ The National Instruments software for data acquisition instruments.

NI-VISA The National Instruments implementation of the VISA standard—An interface-independent software that provides a unified programming interface for VXI, GPIB, and serial instruments.

P

PCI	Peripheral Component Interconnect—The PCI bus is a high-performance 32-bit or 64-bit bus with multiplexed address and data lines.
PCMCIA	Personal Computer Memory Card International Association.
peripheral	Any hardware device connected to a computer, such as a monitor, keyboard, printer, plotter, disk or tape drive, graphics tablet, scanner, mouse, and so on.
PXI Express	PCI eXtensions for Instrumentation—An open implementation of CompactPCI Express that adds electrical features that meet the high-performance requirements of instrumentation applications by providing triggering, local buses, and system clock capabilities. PXI Express also offers two-way interoperability with CompactPCI Express products.

R

RAM	Random Access Memory—The computer's primary workspace.
resource	Hardware settings used by devices in a computer system, including ISA interrupt level, DMA channel, and I/O address.
RMS	Root mean squared. <i>See also</i> g_{rms} .

S

s	Seconds.
SDRAM	Synchronous Dynamic RAM (Random Access Memory)—Storage that the computer must refresh at frequent intervals.
SO-DIMM	Small Outline Dual In-line Memory Module.
SPI Bus	Serial Peripheral Interface—A standard for controlling most any digital electronics that accept a clocked serial stream of bits.

U

USB Universal Serial Bus.

V

V Volts.

VGA Video Graphics Array—The minimum video display standard for all PCs.

W

W Watts.

Index

A

Advanced Setup menu, 2-6

B

BIOS

checking settings, 4-1

Diagnostic Utilities, 2-16

flashing new BIOS, 4-5

setup

Advanced Setup menu, 2-6

Boot Settings Configuration menu, 2-13

Boot Setup menu, 2-12

CD/DVD ROM Drive BBS Priorities Configuration menu, 2-14

CPU configuration menu, 2-7 entering, 2-4

ExpressCard Configuration menu, 2-8

Floppy Drive BBS Priorities Configuration menu, 2-14

Hard Drive BBS Priorities Configuration menu, 2-14

LabVIEW RT options menu, 2-11

LabVIEW RT Options Setup menu Configuration Overrides menu, 2-12

Main Setup menu, 2-5

Network Device BBS Priorities Configuration menu, 2-14

SATA Configuration menu, 2-7

Save & Exit menu, 2-15

Serial/Parallel Port Configuration menu

Parallel Port menu, 2-10, 2-11

Serial Port menu, 2-10

USB configuration menu, 2-9

Video Configuration menu, 2-8

boot options, configuring controller, 4-2

Boot Settings Configuration menu, 2-13

Boot Setup menu, 2-12

C

calibration certificate (NI resources), B-2

CD/DVD ROM Drive BBS Priorities menu, 2-14

CE compliance, specifications, A-5

CMOS

clearing contents (figure), 2-17, 5-3
setting back to default, 5-2

COM1 connector

connector locations and pinout (figure), 3-5

connector signals (table), 3-5

common configuration questions

boot options, 4-2

cables and connections, 4-3

driver installation, 4-4

general questions, 4-1

PXI Express configuration, 4-6

upgrade information, 4-4

configuration, common questions

boot options, 4-2

cables and connections, 4-3

driver installation, 4-4

general questions, 4-1

PXI Express configuration, 4-6

upgrade information, 4-4

configuration, PXI Express chassis, 2-22

connectors

- COM1 connector and signals, 3-5
- DisplayPort connector and signals, 3-3
- Ethernet connector and signals, 3-6
- parallel port connector and signals, 3-7
- peripheral expansion overview (table), 3-1
- trigger connector and signals, 3-11
- Universal Serial Bus (USB) connector and signals, 3-9

controller reset pushbutton, 3-12

conventions used in the manual, *xi*

CPU Configuration menu, 2-7

D

data storage, 3-12

DDR3 SO-DIMMs

- from National Instruments (note), 2-24, 4-5
- installing, 4-4
 - figure, 2-24, 4-5

Declaration of Conformity (NI resources), B-2

diagnostic tools (NI resources), B-1

directories and files installed on hard drive, 2-22

DisplayPort, connector signals (table), 3-3

documentation

- conventions used in manual, *xi*
- how to use this documentation set, *xi*
- NI resources, B-1
- related documentation, *xii*

drivers

- directory, 2-22
- installation
 - video, 4-4
- NI resources, B-1
- obtaining latest drivers, 4-5

E

electrical specifications, A-2

electromagnetic compatibility, A-4

environmental management

- specifications, A-5
- WEEE information, A-5

Ethernet, connector, 3-1

location and pinout (figure), 3-6

signals (table), 3-6

examples (NI resources), B-1

F

features of PXI Express, 2-22

files and directories installed on hard drive, 2-22

Floppy Drive BBS Priorities menu, 2-14

front panel

connectors

- Ethernet, 3-1
- parallel port, 3-1, 3-7
- PXI trigger, 3-1
- serial, 3-1, 3-5
- trigger, 3-11
- USB, 3-1, 3-9
- video, 3-1, 3-3

dimensions, 3-2

features, 3-12

LEDs, 4-1

functional overview of NI PXIe-8820, 1-2

H

hard drive, 3-12

files and directories installed on, 2-22

recovery, 2-25

hard drive BBS priorities menu, 2-14

help, technical support, B-1

I

images directory, 2-22

installation

See also configuration

injector/ejector handle position
(caution), 2-2

NI PXIe-8820 installed in a PXI Express
chassis (figure), 2-3

procedure, 2-1

removing NI PXIe-8820 from PXI
Express chassis, 2-4

removing protective screw caps
(figure), 2-2

installing an OS

from USB CD/DVD-ROM, 2-25
overview, 2-25

installing the video driver, 4-4

instrument drivers (NI resources), B-1

K

keyboard, plugging PS/2 mouse and keyboard
into controller, 4-3

KnowledgeBase, B-1

L

LabVIEW, 1-4

RT configuration switches, 2-19

RT installation and configuration, 2-18

RT options menu, 2-11

RT software installation, 2-18

LabVIEW RT

configuration switches
figure, 2-21

LabVIEW RT Options Setup Menu

LabVIEW RT Configuration Overrides
Submenu, 2-12

LabWindows/CVI, 1-5

LEDs, front panel LEDs, 3-12, 4-1

Linux support, 1-6

LPT cable, connecting to NI PXIe-8820, 4-3

M

Main Setup menu, 2-5

mating connector parallel port, 3-7

Measurement Studio, 1-4

modular instruments, 1-5

mouse, plugging PS/2 mouse and keyboard
into controller, 4-3

N

National Instruments software, 1-4

National Instruments support and
services, B-1

Network Device BBS Priorities menu, 2-14

NI PXIe-8820

benefits of PXI Express, 1-1

BIOS setup utility, 2-4

block diagram, 1-3

connectors

COM1 connector and signals, 3-5

DisplayPort connector and signals
(table), 3-3

parallel port connector and
signals, 3-7

trigger connector and signals, 3-11

Universal Serial Bus (USB)
connector and signals, 3-9

data storage, 3-12

description, 1-2

front panel

connectors, 3-1

controller reset pushbutton, 3-12

dimensions, 3-2

features, 3-12

LEDs, 4-1

functional overview, 1-2

hard drive recovery, 2-25

- installing DDR SO-DIMMs (figure), 2-24, 4-5
- installing in a PXI Express chassis, 2-1
 - figure, 2-3
- logic blocks, 1-3
- peripheral expansion overview (table), 3-1
- PXI Express trigger connectivity, 2-22
- removing from a PXI Express chassis, 2-4
- software, 1-4
- specifications, A-1
- troubleshooting, 5-1
- upgrading RAM, 2-24, 4-4

NI-DAQmx, 1-5

NI-VISA, 1-5

O

- operating environment specifications, A-2, A-3
- OS installation
 - from USB CD/DVD-ROM, 2-25
 - overview, 2-25

P

- parallel port
 - connector, 3-1
 - connector location and pinout (figure), 3-7
 - connector signals (table), 3-8
- peripheral expansion overview (table), 3-1
- physical specifications, A-2
- POWER OK LED, 3-12
- Power/Wake configuration menu, 2-8
- programming examples (NI resources), B-1
- protective screw caps, removing (figure), 2-2
- PS/2, plugging PS/2 mouse and keyboard into controller, 4-3

- PXI Express
 - chassis configuration, 2-22
 - features, 2-22
 - trigger connectivity, 2-22
- PXI trigger connector, 3-1

R

- RAM
 - DDR3 SO-DIMMs from National Instruments (note), 2-24, 4-5
 - upgrading, 2-24, 4-4
- recycling
 - hardware, A-5
- related documentation, *xii*

S

- safety specifications, A-4
- SATA Configuration menu, 2-7
- Save & Exit menu, 2-15
- Serial ATA controller, using SCSI hard drive in addition, 4-1
- serial port, 3-1
- Serial/Parallel Port Configuration menu, 2-10
 - Memory Configuration menu, 2-11
 - Parallel Port menu, 2-10
 - Serial Port menu, 2-10
- setting up the NI PXIe-8820 BIOS, 2-4
- shock and vibration specifications, A-3
- software
 - See also* drivers
 - installed on your hard drive, 2-22
 - LabVIEW, 1-4
 - LabWindows/CVI, 1-5
 - Measurement Studio, 1-4
 - National Instruments software, 1-4
 - NI-DAQmx, 1-5
 - NI resources, B-1
 - NI-VISA, 1-5
- specifications, A-1

- CE compliance, A-5
 - electrical, A-2
 - electromagnetic compatibility, A-4
 - environmental management, A-5
 - WEEE information, A-5
 - online product certification, A-5
 - operating environment, A-2, A-3
 - physical, A-2
 - safety, A-4
 - shock and vibration, A-3
 - storage environment, A-3
- storage environment specifications, A-3
- support, technical, B-1
- switches LabVIEW RT configuration (figure), 2-21
- system CMOS, 2-17

T

- technical support, B-1
- training and certification (NI resources), B-1
- trigger, 3-11, 4-6
 - connector location and pinout (figure), 3-11
 - connector signals (table), 3-11
- troubleshooting
 - CMOS reset, 5-2
 - controller does not boot, 5-1
 - damaged module, 5-2
 - NI resources, B-1
 - video display, 5-2

U

- Universal Serial Bus (USB)
 - connector location and pinout (figure), 3-9
 - connector signals (table), 3-9
 - overview (table), 3-1

- USB configuration menu, 2-9

USER LEDS

- USER1, 3-12
- USER2, 3-12

V

VGA

- location and pinout (figure), 3-3
- overview (table), 3-1
- video, 3-1
 - See also* VGA
 - driver installation, 4-4
- Video Configuration menu, 2-8

W

- Wake On LAN, 3-6, 4-1
- Web resources, B-1
- WEEE information, A-5

Y

Y-splitter cable

- figure, 4-3
- using mouse and keyboard without, 4-3
- using with PS/2 mouse and keyboard, 2-3