

COMPREHENSIVE SERVICES

We offer competitive repair and calibration services, as well as easily accessible documentation and free downloadable resources.

SELL YOUR SURPLUS

We buy new, used, decommissioned, and surplus parts from every NI series. We work out the best solution to suit your individual needs.

 Sell For Cash  Get Credit  Receive a Trade-In Deal

OBSOLETE NI HARDWARE IN STOCK & READY TO SHIP

We stock **New**, **New Surplus**, **Refurbished**, and **Reconditioned** NI Hardware.



Bridging the gap between the manufacturer and your legacy test system.

 1-800-915-6216

 www.apexwaves.com

 sales@apexwaves.com

All trademarks, brands, and brand names are the property of their respective owners.

Request a Quote

 **CLICK HERE**

PXI-8840

GETTING STARTED GUIDE

NI PXI-8840

This document includes instructions for installing and configuring your NI PXI-8840 PXI controller module.

For complete configuration information (including BIOS configuration, ExpressCard installation, hard drive recovery, memory upgrade, and OS installation), full specifications, and I/O information, refer to the *NI PXI-8840 User Manual*.

Contents

Getting Started.....	2
Electromagnetic Compatibility Guidelines.....	2
Unpacking.....	2
Electrical.....	3
Preparing the Environment.....	3
Installing the NI PXI-8840 into a PXI Chassis.....	4
LabVIEW RT.....	6
Drivers and Software.....	8
Data Storage.....	8
NI PXI-8840 Front Panel.....	9
Removing the NI PXI-8840 from a PXI Chassis.....	11
Cleaning.....	11
Common Configuration Questions.....	11
General Questions.....	11
Boot Options.....	12
Cables and Connections.....	12
Software Driver Installation.....	13
Upgrade Information.....	14
PXI Configuration.....	15
Troubleshooting.....	15
What if the Controller Does Not Boot?.....	15
What If I Can't See The Video?.....	16
My system boots fine as long as a particular module is not in my chassis. How do I boot the chassis with the module installed?.....	16
My chassis or controller does not appear in MAX. How do I use MAX to identify and configure my PXI system?.....	17
My CMOS is corrupted. How do I set it back to default?.....	17
Worldwide Support and Services.....	18

Getting Started

This section includes instructions for unpacking and installing your NI PXI-8840 controller, including setting up your controller to run LabVIEW Real-Time. It also describes the controller's front panel connectors.

Electromagnetic Compatibility Guidelines

This product was tested and complies with the regulatory requirements and limits for electromagnetic compatibility (EMC) stated in the product specifications. These requirements and limits provide reasonable protection against harmful interference when the product is operated in the intended operational electromagnetic environment.

This product is intended for use in industrial locations. However, harmful interference may occur in some installations, when the product is connected to a peripheral device or test object, or if the product is used in residential or commercial areas. To minimize interference with radio and television reception and prevent unacceptable performance degradation, install and use this product in strict accordance with the instructions in the product documentation.

Furthermore, any changes or modifications to the product not expressly approved by National Instruments could void your authority to operate it under your local regulatory rules.



Caution To ensure the specified EMC performance, operate this product only with shielded cables and accessories.



Caution To ensure the specified EMC performance, all I/O cables except connected Ethernet, serial, USB, and GPIB cables must be no longer than 3 m (10 ft.). Serial, USB, and GPIB cables must be no longer than 30 m (100 ft.). Ethernet cables can be longer than 30 m (100 ft.).

Unpacking

The NI PXI-8840 ships in an antistatic package to prevent electrostatic discharge from damaging device components. To prevent such damage when handling the device, ground yourself using a grounding strap or by holding a grounded object, such as your computer chassis, and complete the following steps:

1. Touch the antistatic package to a metal part of the chassis before removing the device from the package.



Caution Never touch the exposed pins of connectors.

2. Remove the device from the package and inspect the device for loose components or any other sign of damage.
3. Notify National Instruments if the device appears damaged in any way. Do *not* install a damaged device into your chassis.

Electrical



Note Does not include any attached USB devices or ExpressCard.

Voltage (V)	Current (Amps) Typical	Current (Amps) Maximum
+3.3 V	1.12 A	1.84 A
+5 V (+5 V _{DC} and +5 V _{IO})	8.92 A	14.97 A
+12 V	0.18 A	0.27 A
-12 V	0 A	0 A

Preparing the Environment

Ensure the environment you are using the NI PXI-8840 in meets the following specifications.



Caution The operating temperature must not be exceeded, even when used in a chassis with a higher temperature range.

Ambient temperature range^{1, 2}

Base.....5 °C to 50 °C³ (Tested in accordance with IEC-60068-2-1 and IEC-60068-2-2.)

Extended Temperature Option.....0 °C to 55 °C (Tested in accordance with IEC-60068-2-1 and IEC-60068-2-2. Meets MIL-PRF-28800F Class 3 low temperature limit and MIL-PRF-28800F Class 2 high temperature limit.)

Relative humidity range.....10 to 90%, noncondensing (Tested in accordance with IEC-60068-2-56.)

Maximum altitude.....2,000 m

Pollution Degree.....2

Indoor use only.



Note Refer to the *NI PXI-8840 User Manual* for full NI PXI-8840 specifications.

¹ For chassis that are not available in the online catalog at ni.com, contact National Instruments for supported operating temperatures.

² Processor should not throttle CPU frequency under reasonable, worst case processor work loads in high operating temperatures.

³ 5 °C to 40 °C for the NI PXI-1000B DC.

Installing the NI PXI-8840 into a PXI Chassis

To install the NI PXI-8840 into a PXI chassis, complete the following steps.

1. Plug in your chassis before installing the NI PXI-8840. The power cord grounds the chassis and protects it from electrical damage while you install the module.



Caution In some National Instruments chassis, such as the NI PXI-1042, you must ensure that the power LED is off. For more information about chassis power behavior, refer to the user manual for the specific chassis.



Caution To protect both yourself and the chassis from electrical hazards, leave the chassis off until you finish installing the NI PXI-8840.

2. Remove any panels blocking access to the system controller slot (Slot 1) in the chassis.
3. Touch the metal part of the chassis case to discharge any static electricity that might be on your clothes or body.
4. Remove the protective plastic covers from the four bracket-retaining screws as shown in the following figure.

Figure 1. Removing Protective Plastic Covers

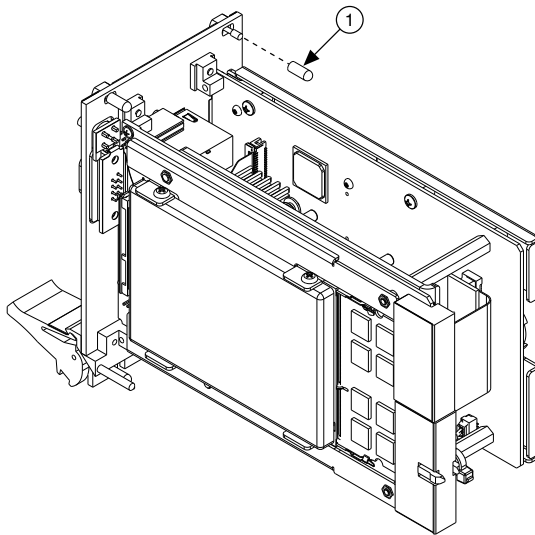

1. Protective Screw Cap (4x)

5. Make sure the injector/ejector handle is in its downward position. Align the NI PXI-8840 with the card guides on the top and bottom of the system controller slot.



Caution Do *not* raise the injector/ejector handle as you insert the NI PXI-8840. The module will not insert properly unless the handle is in its downward position so that it does not interfere with the injector rail on the chassis.

6. Hold the handle as you slowly slide the module into the chassis until the handle catches on the injector/ejector rail.
7. Raise the injector/ejector handle until the module firmly seats into the backplane receptacle connectors. The front panel of the NI PXI-8840 should be even with the front panel of the chassis.
8. Tighten the four bracket-retaining screws on the top and bottom of the front panel to secure the NI PXI-8840 to the chassis.
9. Check the installation.
10. Connect the keyboard and mouse to the appropriate connectors. If you are using a PS/2 keyboard and a PS/2 mouse, a Y-splitter adapter is available to connect both to a single USB connector. National Instruments offers a Y-splitter adapter cable, part number 778713-02, available through the online catalog at ni.com/products.
11. Connect the DisplayPort monitor video cable to the DisplayPort connector, or use the DisplayPort-to-VGA adapter included with your controller to connect a VGA monitor to the DisplayPort connector.
12. Connect devices to ports as required by your system configuration.
13. Power on the display. Refer to the *NI PXI-8840 User Manual* for details.
14. Power on the chassis.
15. Verify that the controller boots. If it does not boot, refer to the *Troubleshooting* section.

The following figure shows an NI PXI-8840 controller installed in the system controller slot of an NI PXI-1042 chassis.

Figure 2. NI PXI-8840 Installed in a PXI Chassis

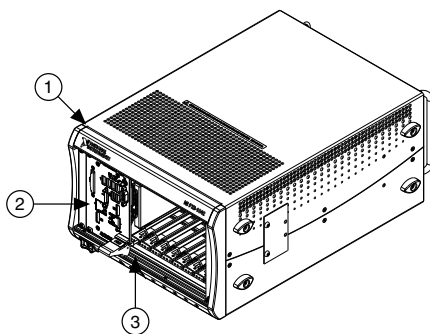

1. PXI Chassis
2. PXI Controller
3. Injector/Ejector Rail

LabVIEW RT

This section explains software installation and switch configuration for LabVIEW RT on your PXI controller.

LabVIEW RT Software Installation

The following section describes the necessary steps to get your PXI embedded controller set up to run LabVIEW Real-Time. In this section you will configure the controller boot mode, verify or change IP settings, and install LabVIEW Real-Time software.

Complete the following steps to install the LabVIEW RT software.

1. Boot the NI PXI embedded controller into the real-time operating system. Refer to the *LabVIEW RT Configuration Switches* section or the *LabVIEW RT Setup Menu* section in this document to configure the controller for booting into LabVIEW RT.

The PXI controller automatically boots into LabVIEW RT Safe Mode when no software is installed. LabVIEW RT Safe Mode loads with the basic real-time operating system and automatically attempts to connect to the network using DHCP. If DHCP is not available, it then connects to the network with a link-local IP address.



Tip You can connect a monitor to the desktop PC to display startup messages such as the IP address.

2. Open Measurement & Automation Explorer (MAX) on another computer in the same subnet and expand the **Remote Systems** branch. MAX lists the PXI controller as the controller model name followed by the MAC address (for example, **NI-PXI-8840 00802f108562**).



Note The other computer must have LabVIEW, LabVIEW RT, and any desired drivers installed.



Tip Record the PXI controller MAC address, located on the side of the controller, for use in identifying the controller. You also can remove the label and place it on the front of the controller for easier access.

3. Click the appropriate PXI controller entry to access the **Network Settings** tab in the right pane view.
4. (Optional) Enter a name for the RT target in the **Name** text box.
5. (Optional) Set the network configuration options of the RT target in the **IP Settings** section and click the **Apply** button.

For information about configuring network settings, refer to the *Configuring Network Settings* book, accessible by browsing to **MAX Remote Systems Help»LabVIEW Real-Time Target Configuration»Configuring Network Settings** from the **Contents** tab of *MAX Help*.



Note When any IP or identification settings are changed, you are prompted to reboot the controller for the changes to take effect. Click **Yes** to reboot the RT

target automatically. You may also reboot the controller by right-clicking the target name under **Remote Systems** and selecting **Reboot**.

After rebooting the PXI controller, it appears in the **Remote Systems** category with the assigned name.

6. Expand the PXI controller view in the **Remote Systems** branch and select **Software**.
7. Click the **Add/Remove Software** button in the toolbar to launch the LabVIEW Real-Time Software Wizard.
8. Install the LabVIEW Real-Time software and device drivers that you require on the RT target. Refer to the NI Web site at ni.com/info and enter the Info Code `etspc` for the latest information about supported software.

After software installation, the controller automatically reboots, and you now can program it using LabVIEW Real-Time.



Note Refer to the *RT Getting Started Guide* on your host computer for more information about setting up your RT target.

LabVIEW RT Configuration Switches

Use the LabVIEW RT configuration switches to configure LabVIEW RT if it is installed on the controller. If you are not using LabVIEW RT, these switches should remain in the OFF position. The controller reads these switches only after a system reset.

The NI PXI-8840 controller includes the following LabVIEW RT configuration switches:

- Switch 1—**Boot LabVIEW RT**: Set this switch to ON to boot LabVIEW RT.
- Switch 2—**Boot Safe Mode**: Set this switch to ON to boot LabVIEW RT into safe mode to reconfigure TCP/IP settings and to download or update software from a host computer. This switch overrides the behavior of Switch 1. Booting the controller into safe mode does not start the embedded LabVIEW RT engine. After changing the settings or software, reboot the controller with this switch OFF to resume normal operation.
- Switch 3—**Disable Startup VI**: Set this switch to ON to prevent VIs from automatically running at startup if the controller becomes inaccessible because of a startup VI.
- Switch 4—**Reset IP Address**: Set this switch to ON to reset the IP address and other TCP/IP settings to their factory defaults. Use this switch if moving the controller to a different subnet or if the current TCP/IP settings are valid.



Note By default, the target automatically attempts to connect to the network using DHCP. If the target cannot initiate a DHCP connection, the target connects to the network with a link-local IP address or `169.254.x.x`.

The following figure shows the location of the LabVIEW RT configuration switches. The switches are shown in the OFF position.

Figure 3. LabVIEW RT Configuration Switches

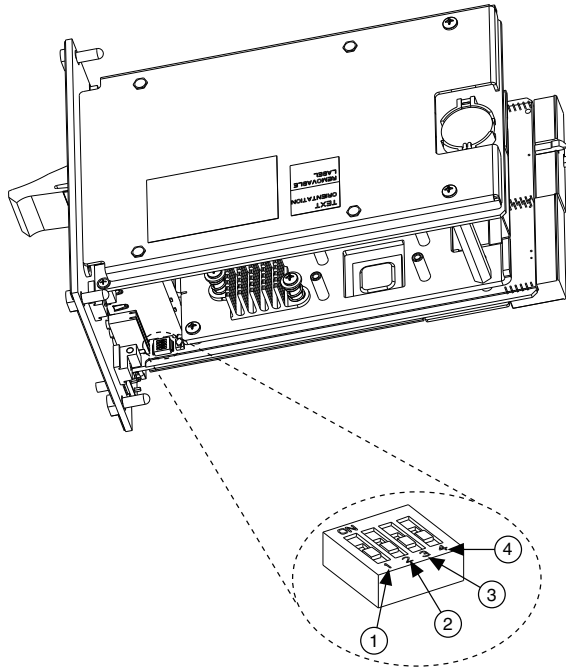

1. Switch 1—Boot LabVIEW RT
2. Switch 2—Boot Safe Mode

3. Switch 3—Disable Startup VI
4. Switch 4—Reset IP Address

Drivers and Software

Your hard drive includes a directory called `images` in its root that contains software and soft copies of manuals for the peripherals. The directory structure under the `images` directory is logically organized into several levels.

In the `images` directory are `drivers` and `NIDRIVERS` directories. The `drivers` directory contains driver installers for the system peripherals. These files and directories are copied exactly from the manufacturer distribution disks, so the naming conventions vary from peripheral to peripheral. The `NIDRIVERS` directory contains the GPIB and PXI Platform Services drivers preinstalled on the controller.

Data Storage

The NI PXI-8840 has the following data storage features:

- 2.5 in. SATA notebook internal hard drive
- USB storage support—USB CD/DVD-ROM, mass storage device, or floppy drive

NI PXI-8840 Front Panel

The following figure shows the NI PXI-8840 front panel layout.

Figure 4. NI PXI-8840 Front Panel Layout

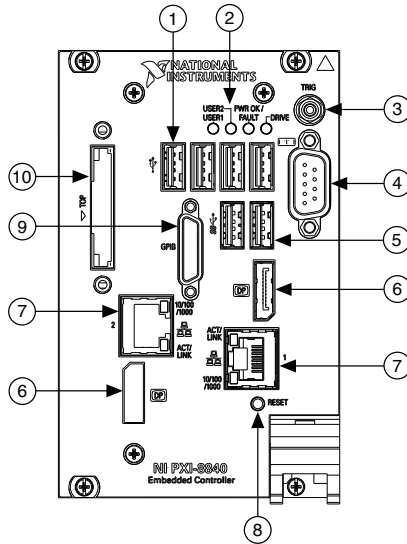

- | | |
|------------|--------------------|
| 1. USB 2.0 | 6. DisplayPort |
| 2. LEDs | 7. Ethernet |
| 3. Trigger | 8. Reset Button |
| 4. COM1 | 9. GPIB |
| 5. USB 3.0 | 10. ExpressCard/34 |

Front Panel Connectors

The following table lists various peripherals and their corresponding NI PXI-8840 external connectors, bus interfaces, and functions.

Peripheral	External Connector	Description
Video	DisplayPort	Intel® HD Graphics controller
Serial	COM1 (9-pin DSUB)	16550 RS-232 serial port
Ethernet	LAN (RJ45)	10/100/1000 Ethernet connection

Peripheral	External Connector	Description
USB	USB 4-pin Series A stacked receptacle (4 ports)	Hi-Speed USB
	USB 9-pin Series A stacked receptacle (2 ports)	SuperSpeed USB, backwards compatible with USB 2.0
PXI trigger	Trigger (SMB)	Routing PXI triggers to or from the backplane trigger bus
GPIB device	GPIB (25-pin Micro D)	General-Purpose Interface Bus, IEEE 488.1
ExpressCard/34 module	ExpressCard/34 slot	ExpressCard/34 Expansion

PXI Trigger Connectivity

The SMB connector on the NI PXI-8840 front panel can connect to or from any PXI backplane trigger line. A trigger allocation process is needed to prevent two resources from connecting to the same trigger line, resulting in the trigger being double-driven and possibly damaging the hardware. At the time of this manual's publication, this software is not yet available for Windows. Contact National Instruments for more information.

Front Panel Features

The NI PXI-8840 has the following front-panel features:

- A controller reset push button (press the button to generate a reset to the controller)
- Two front panel LEDs that show PC status:
 - **DRIVE LED**— Indicates when an access to the internal hard disk is occurring.
 - **PWR OK/FAULT LED**—Indicates the controller status. The LED indicates one of the following states:
 - **Green ON steady**—PXI and onboard power is on and within regulation limits.
 - **Green BLINKING**—One of the onboard power supplies is operating outside of the normal limits or the system power supply is out of regulation.
 - **OFF**—The controller is powered off.
 - **Red BLINKING**—The controller detected a power rail fault when trying to boot.
 - **USER LEDs** — Two bi-color green/yellow LEDs (**USER1** and **USER2**) that you can define to meet the needs of your LabVIEW application.

Removing the NI PXI-8840 from a PXI Chassis

To remove the NI PXI-8840 from a PXI chassis, complete the following steps.

1. Power off the chassis.
2. Remove any cables that may be attached to the controller front panel.
3. Unscrew the four bracket-retaining screws in the front panel.
4. Press the injector/ejector handle down.
5. Slide the unit out of the chassis.

Cleaning

Use a dry, low-velocity stream of air to clean the NI PXI-8840 controller. If needed, use a soft, nonmetallic brush for cleaning around components.

Make sure that the device is completely dry and free from contaminants before returning it to service.

Common Configuration Questions

This section answers common configuration questions you may have when using an NI PXI-8840 embedded controller.

General Questions

What do the LEDs on the front panel mean?

Refer to the LED status descriptions in the *Front Panel Features* section.

How do I check the configuration of the memory, hard drive, time/date, and so on?

You can view these parameters in the BIOS setup. Complete the following steps to enter the BIOS setup:

1. Reboot the NI PXI-8840.
2. Press <Delete> during the memory tests.

Refer to the *Accessing BIOS Setup Utility* section of the *NI PXI-8840 User Manual* for more information.

Can I use the internal Serial ATA drive and an external hard drive at the same time?

Yes. Refer to the *BIOS Setup Utility* section of the *NI PXI-8840 User Manual* for more information.

Boot Options

What devices can I boot from?

The NI PXI-8840 can boot from the following devices:

- The internal Serial ATA hard drive.
- An external SCSI hard drive or SCSI CD/DVD-ROM if a SCSI adapter, such as the PXI-8214, is used.
- A network PXE server on the same subnet.
- An external USB mass storage device such as a USB hard drive, USB CD/DVD-ROM, or USB flash drive.
- An external USB floppy drive.
- Most PCI or PCI Express-based devices that provide an Option ROM.



Note There are limitations when booting from a USB device. You can install Windows 7 and later from a USB CD/DVD-ROM, but not earlier versions of Windows. The NI PXI-8840 BIOS configures the USB devices so that they work in a DOS environment.

How do I configure the controller to boot from these devices?

You can configure the controller to permanently or temporarily change the boot order.

There are two methods.

- Enter Setup and select the **Boot** menu. You will see a list of all bootable devices, ordered by device type. You can set the boot order using <+> and <->. Set the order by device type and set the order for the devices listed within the device type.
- To boot from a different device without changing the boot order in the BIOS, press <F10> continuously while booting. After the BIOS completes the POST and just before the controller boots the OS, the **Boot** menu is displayed. You can select the device type you want to boot from.

Cables and Connections

How do I plug both a PS/2 mouse and PS/2 keyboard into the controller?

The NI PXI-8840 has no PS/2 connector, and you need to use a USB Y-splitter cable as shown below, or a similar device, to connect both a PS/2 mouse and PS/2 keyboard. National Instruments part number 778713-01 is such a cable and is available through the online catalog at ni.com/products.

Figure 5. Y-Splitter Cable

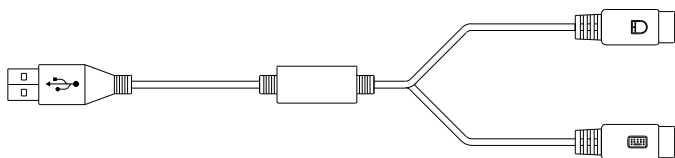

What if I don't have a Y-splitter cable? Can I still use a mouse and keyboard?

If you do not have a Y-splitter cable, plug a USB keyboard into any USB connector. You can also plug a USB mouse into any USB connector.

How do I connect a VGA monitor to the NI PXI-8840?

A DisplayPort-to-VGA adapter (part number 782271-01) is included with your kit. You can use this adapter to connect a VGA monitor to a DisplayPort connector.

How do I connect two monitors to the NI PXI-8840?

The NI PXI-8840 includes two DisplayPort connectors. You can connect each to a separate monitor for dual monitor support.

Software Driver Installation

How do I install or reinstall the video driver?

Refer to KnowledgeBase 3H3COSD8, *What Peripheral Drivers Should I Use with My PXI or VXI Controller?*, at ni.com/support.

How do I install or reinstall the Ethernet driver?

Refer to KnowledgeBase 3H3COSD8, *What Peripheral Drivers Should I Use with My PXI or VXI Controller?*, at ni.com/support.

How do I install or reinstall the GPIB driver?

The NI-488.2 driver for your GPIB port is installed by default when your controller is first shipped from the factory. To change the default installed driver, complete the following steps:

1. Download the latest GPIB driver from ni.com/downloads.
2. Install the driver and verify that the driver has properly detected the GPIB device in the Device Manager. If you need more assistance, refer to ni.com/support/install.

How do I install software from a CD?

The compact size of the NI PXI-8840 does not allow for an integrated USB CD/DVD-ROM drive. You have the following options:

USB CD/DVD-ROM	You can install from a USB CD/DVD-ROM using a bootable installation CD.
SCSI CD-ROM	Other types of CD-ROM drives are available. Check with the vendor to make sure Windows 7 supports the drive.
Mapped network drive	You can use the Ethernet to connect to another computer. If you share the USB CD/DVD-ROM drive on the other computer, you can map the shared USB CD/DVD-ROM drive to a drive letter on the NI PXI-8840.

A USB CD/DVD-ROM drive is available from National Instruments, part number 778492-01.

Upgrade Information

How do I upgrade system memory?

You can change the amount of installed RAM on the NI PXI-8840 by upgrading the DDR3L SO-DIMM. Complete the following steps to upgrade the RAM.

1. Remove the NI PXI-8840 from the PXI chassis.
2. Locate the DDR3L SO-DIMM module on the side of the controller, as shown in the following figure.
3. Install the new DDR3L SO-DIMM module into the slot.

NI PXI-8840 System Memory Information

National Instruments offers the following types of SO-DIMMs for use with the NI PXI-8840 controller.

- 1600 MHz DDR3L PC3-12800 4 GB, 512 MB × 64, 1.18 in. max (NI part number 782341-4096)
- 1600 MHz DDR3L PC3-12800 8 GB, 1024 MB × 64, 1.18 in. max (NI part number 783001-8192)



Note National Instruments has tested and verified that the DDR3L SO-DIMMs we sell work with the NI PXI-8840 controller. We recommend you purchase your DDR3L SO-DIMM modules from National Instruments. Other off-the-shelf DDR3L SO-DIMM modules are not guaranteed to work properly.

Figure 6. Installing a DDR3L SO-DIMM in an NI PXI-8840 Controller

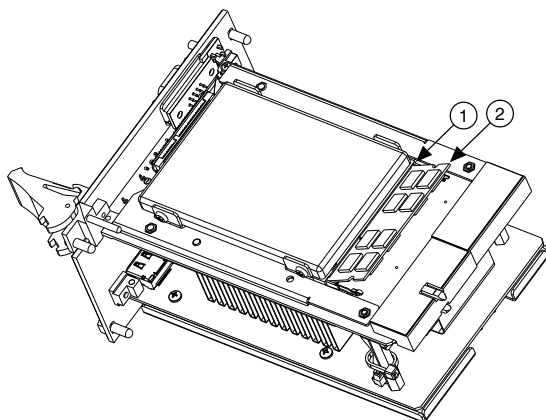

1. DDR3L SO-DIMM Socket
 2. DDR3L SO-DIMM Module
-

How do I flash a new BIOS?

You can download the new BIOS from ftp.ni.com/support/pxi. For more information, refer to KnowledgeBase 2GIGKD0Z, [Determining and Upgrading PXI and VXI Embedded Controller BIOS Versions](#).

Where do I get the latest software drivers?

The latest National Instruments software is available from ni.com/downloads. For peripheral drivers, refer to KnowledgeBase 3H3COSD8, [What Peripheral Drivers Should I Use with My PXI or VXI Controller?](#), at ni.com/support.

PXI Configuration

How do I use the SMB trigger on the front panel?

Refer to the *PXI Trigger Connectivity* section for details on using the SMB trigger.

Troubleshooting

This section answers common troubleshooting questions you may have when using the NI PXI-8840 embedded controller.

What if the Controller Does Not Boot?

Several problems can cause a controller not to boot. Here are some things to look for and possible solutions.

Things to Notice:

- Which LEDs come on? The **PWROK/FAULT** LED should stay lit green. The **Drive** LED should blink during boot as the disk is accessed.
- What appears on the display? Does it hang at some particular point (BIOS, Operating System, and so on)? If nothing appears on the screen, try a different monitor. Does your monitor work with a different PC? If it hangs, note the last screen output that you saw for reference when consulting National Instruments technical support.
- What has changed about the system? Did you recently move the system? Was there electrical storm activity? Did you recently add a new module, memory chip, or piece of software?
- Refer to your chassis documentation for additional troubleshooting steps.

Things to Try:

- Make sure the chassis is plugged in to a working power source.
- Check any fuses or circuit breakers in the chassis or other power supply (possibly a UPS).
- Make sure the controller module is firmly seated in the chassis.
- Remove all other modules from the chassis.
- Remove any nonessential cables or devices.
- Try the controller in a different chassis.
- Try a similar controller in the same chassis.
- Clear the CMOS.
- Recover the hard drive on the controller.
- Make sure the RAM is properly seated.

What If I Can't See The Video?

This problem usually results from having the video card output set past the limits of the monitor. You will need to boot Windows in Safe Mode. To do this, reboot the controller. As Windows begins to boot, hold down <F8>. You should now be able to reset the video driver to lower settings. Try setting the resolution to 800 × 600 and the refresh rate to 60 Hz. Once you reboot, you can raise these values again, using the test option in Windows. These settings are accessible through the **Advanced** tab of the **Display** item in the **Control Panel**. Alternately, you can try a different monitor, preferably a newer and larger one.

My system boots fine as long as a particular module is not in my chassis. How do I boot the chassis with the module installed?

The most common cause of this problem is a damaged module. Try the module in a different chassis or with a different controller. Also, remove any external cables or terminal blocks connected to the system. If the module does not work in these cases, it is likely damaged. Contact the module manufacturer for further troubleshooting.

My chassis or controller does not appear in MAX. How do I use MAX to identify and configure my PXI system?

If you are using MAX to configure your PXI system, you must install the PXI Platform Services software on your controller to identify NI PXI and PXI Express chassis and modules in MAX. You can install PXI Platform Services from the software CD included with your controller or from ni.com/downloads.

My CMOS is corrupted. How do I set it back to default?

There are two methods that you can use to reset the CMOS.

1. First Method
 - a) Enter the BIOS setup program as described in the *Accessing BIOS Setup Utility* section of the *NI PXI-8840 User Manual* for more information.
 - b) Press <F9> to load BIOS defaults.
 - c) Answer **Y** (Yes) to the verification prompt.
 - d) Select **Save and Exit Setup**.
2. Second Method
 - a) Power off the chassis.
 - b) Remove the controller from the chassis.
 - c) Press the Clear CMOS button (SW1) for 2 to 3 seconds as shown in the following figure.
 - d) Reinstall the controller in the chassis.

Figure 7. Clearing the CMOS Contents

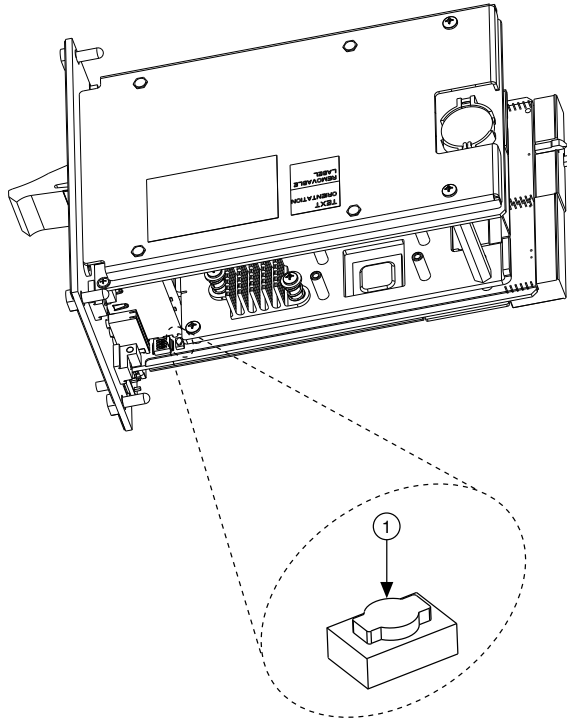

1. Push-Button Switch SW1

Worldwide Support and Services

The National Instruments website is your complete resource for technical support. At ni.com/support, you have access to everything from troubleshooting and application development self-help resources to email and phone assistance from NI Application Engineers.

Visit ni.com/services for NI Factory Installation Services, repairs, extended warranty, and other services.

Visit ni.com/register to register your National Instruments product. Product registration facilitates technical support and ensures that you receive important information updates from NI.

A Declaration of Conformity (DoC) is our claim of compliance with the Council of the European Communities using the manufacturer's declaration of conformity. This system affords the user protection for electromagnetic compatibility (EMC) and product safety. You

can obtain the DoC for your product by visiting ni.com/certification. If your product supports calibration, you can obtain the calibration certificate for your product at ni.com/calibration.

National Instruments corporate headquarters is located at 11500 North Mopac Expressway, Austin, Texas, 78759-3504. National Instruments also has offices located around the world. For telephone support in the United States, create your service request at ni.com/support or dial 1 866 ASK MYNI (275 6964). For telephone support outside the United States, visit the *Worldwide Offices* section of ni.com/global to access the branch office websites, which provide up-to-date contact information, support phone numbers, email addresses, and current events.

Refer to the *NI Trademarks and Logo Guidelines* at ni.com/trademarks for information on National Instruments trademarks. Other product and company names mentioned herein are trademarks or trade names of their respective companies. For patents covering National Instruments products/technology, refer to the appropriate location: **Help»Patents** in your software, the `patents.txt` file on your media, or the *National Instruments Patent Notice* at ni.com/patents. You can find information about end-user license agreements (EULAs) and third-party legal notices in the readme file for your NI product. Refer to the *Export Compliance Information* at ni.com/legal/export-compliance for the National Instruments global trade compliance policy and how to obtain relevant HTS codes, ECCNs, and other import/export data. NI MAKES NO EXPRESS OR IMPLIED WARRANTIES AS TO THE ACCURACY OF THE INFORMATION CONTAINED HEREIN AND SHALL NOT BE LIABLE FOR ANY ERRORS. U.S. Government Customers: The data contained in this manual was developed at private expense and is subject to the applicable limited rights and restricted data rights as set forth in FAR 52.227-14, DFAR 252.227-7014, and DFAR 252.227-7015.

© 2014 National Instruments. All rights reserved.

374582B-01 Aug14