

COMPREHENSIVE SERVICES

We offer competitive repair and calibration services, as well as easily accessible documentation and free downloadable resources.

SELL YOUR SURPLUS

We buy new, used, decommissioned, and surplus parts from every NI series. We work out the best solution to suit your individual needs.

 Sell For Cash  Get Credit  Receive a Trade-In Deal

OBSOLETE NI HARDWARE IN STOCK & READY TO SHIP

We stock **New**, **New Surplus**, **Refurbished**, and **Reconditioned** NI Hardware.



Bridging the gap between the manufacturer and your legacy test system.

 1-800-915-6216

 www.apexwaves.com

 sales@apexwaves.com

All trademarks, brands, and brand names are the property of their respective owners.

Request a Quote

 **CLICK HERE**

AT-DIO-32HS

SCXI-1355 SHIELDED CABLE

This guide describes how to install the SCXI-1355 shielded cable with an adapter board between an SCXI module and a DAQDIO 6533 (DIO-32HS) Series data acquisition (DAQ) board.

Introduction

With the SCXI-1355 shielded cable, you can make a low-noise, long-distance connection between your SCXI chassis and your DAQDIO 6533 Series board. You can use the SCXI-1355 with the DAQDIO 6533 Series AT-DIO-32HS and PCI-DIO-32HS boards.

The SCXI-1355 shielded cable consists of a 1, 2, or 5 m round cable that has a 68-pin female connector at each end. When plugged into the SCXI-1355 adapter board, the shielded cable brings the pinout of the DIO board I/O connector to the SCXI module and to a breakout connector you can use with other SCXI accessories, such as the SCXI-1180 and the SCXI-1351.

What You Need to Get Started

To set up and use your SCXI-1355 cable, you need the following items:

- SCXI-1355 kit
 - Cable adapter board
 - 1, 2, or 5 m SH68-68-D1 cable
 - Two small screws
 - Two cable tie wraps
- SCXI-1355 Shielded Cable Installation Guide*
- SCXI chassis
- SCXI module

- ❑ DAQDIO 6533 Series AT-DIO-32HS or PCI-DIO-32HS board with a 68-pin SCSI type II connector
- ❑ Small Phillips-head screwdriver
- ❑ Small flathead screwdriver
- ❑ Your computer

Installation

Figure 1 shows the components of your SCXI system and how to connect them.

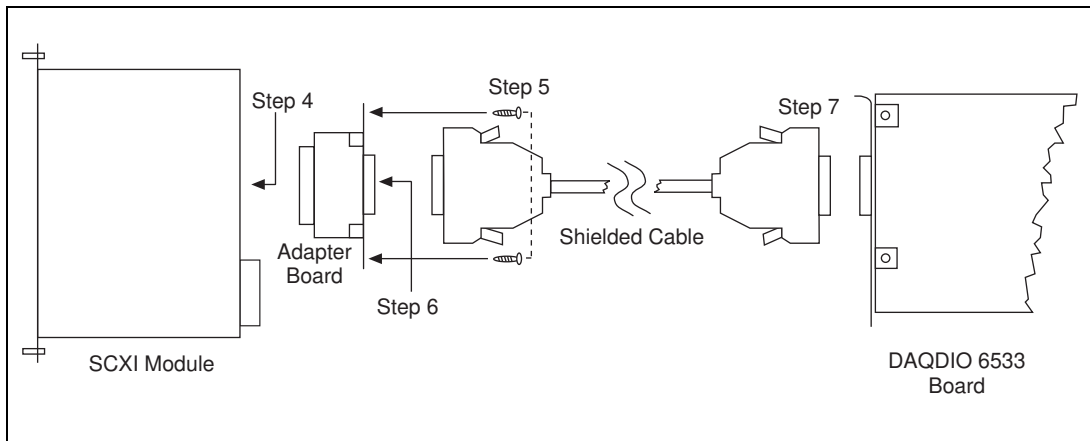

Figure 1. SCXI System Components

Perform the following steps to install the SCXI-1355 cable:

1. Turn off the power to your computer and the SCXI chassis.
2. Install your SCXI modules in the SCXI chassis, following the instructions in your SCXI module user manuals.
3. Set the adapter board switch for parallel mode (P) or serial mode (S). See Figure 2, which also shows the circuit on the DIOA(0) line, for each switch setting.

Use the adapter board, the SCXI module, and DAQDIO 6533 Series board in parallel mode when you want each DIO line to be directly conditioned by an SCXI module channel to which you cable.

Use the system in serial mode when you want to use the DAQDIO 6533 Series board as a communication device to control one or more SCXI modules in the chassis. Check your SCXI module

user manual to make sure that your module supports the mode you want to use and that you have properly configured the necessary jumpers on your SCXI module.

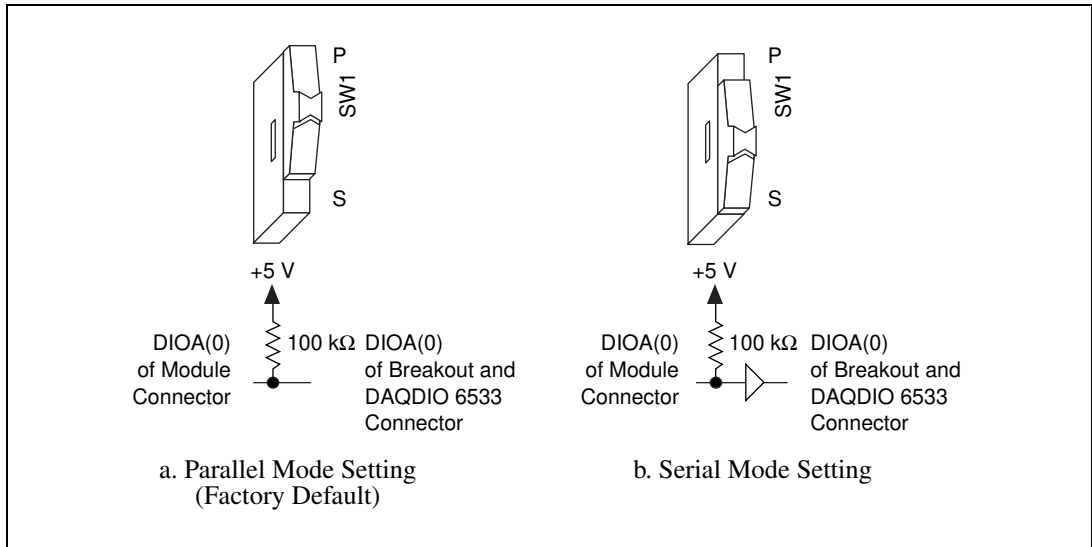

Figure 2. SCXI-1355 Adapter Board Switch SW1 Settings

4. Plug the socket connector of the SCXI-1355 adapter board into the rear signal connector of an SCXI module.
5. Secure the SCXI-1355 adapter board by screwing the two small screws through the rear panel of the adapter board and into the threaded strips in the back of the SCXI chassis.
6. Connect one end of the SCXI-1355 cable to the 68-pin connector of the SCXI-1355 adapter board.
7. Connect the other end of the cable to the I/O connector of the DAQDIO 6533 Series board.
8. Secure the cable to a fixed object with the tie wraps to relieve the strain on the cable. Strain relief is necessary because the SCXI-1355 shielded cable has a long, stiff backshell that can exert leverage on the DAQDIO 6533 Series board connector.

Figure 3 shows the completed installation.

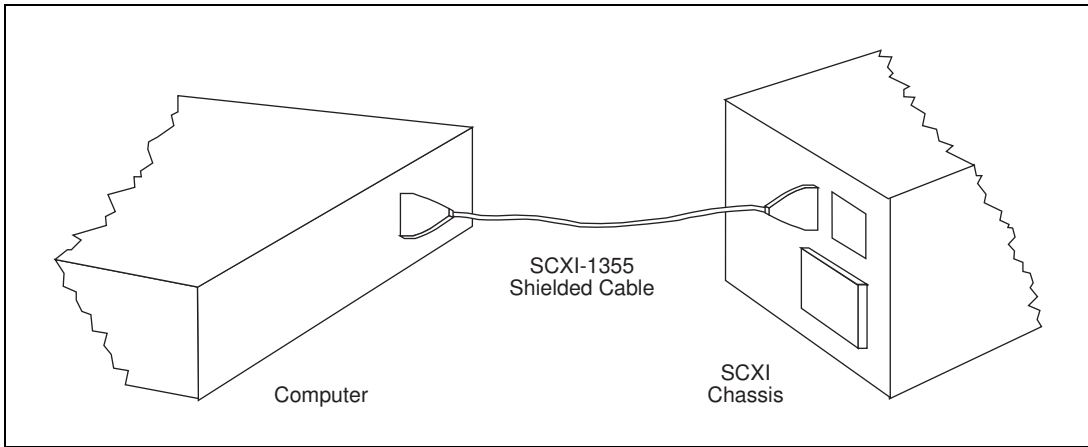

Figure 3. Completed SCXI-1355 Shielded Cable Installation

Pin Assignments

Table 1 lists the pin assignments for the adapter board connectors.

Table 1. Pin Assignments

DAQDIO 6533 Signal Name	DAQDIO 6533 Pin	Breakout Connector Pin ¹	SCXI Module Connector Pin ²
GND	11, 14, 18, 20, 24, 27, 30, 33, 36, 37, 39, 41, 42, 46, 49, 50, 55, 59, 62, 65, 68	17, 19, 21, 23, 25, 26, 28, 30, 32, 34	50
RGND ³	19, 35, 43, 56	17, 19, 21, 23, 25, 26, 28, 30, 32, 34	50
+5 V	1	Not connected	49
DIOA(0) ⁴	10	37	47
DIOA(1)	44	39	45
DIOA(2)	45	38	43
DIOA(3)	12	40	41
DIOA(4)	13	35	39
DIOA(5)	47	42	37
DIOA(6)	48	36	35
DIOA(7)	15	41	33
DIOB(0)	16	47	31
DIOB(1)	17	50	29
DIOB(2)	51	44	27
DIOB(3)	52	48	25
DIOB(4)	53	49	23
DIOB(5)	54	43	21
DIOB(6)	21	46	19
DIOB(7)	22	45	17
DIOC(0)	23	14	15
DIOC(1)	57	12	13
DIOC(2)	58	13	11
DIOC(3)	25	11	9
DIOC(4)	26	16	7
DIOC(5)	60	9	5

Table 1. Pin Assignments (Continued)

DAQDIO 6533 Signal Name	DAQDIO 6533 Pin	Breakout Connector Pin¹	SCXI Module Connector Pin²
DI0C(6)	61	15	3
DI0C(7)	28	10	1
DI0D(0)	29	4	48
DI0D(1)	63	1	46
DI0D(2)	64	7	44
DI0D(3)	31	3	42
DI0D(4)	32	2	40
DI0D(5)	66	8	38
DI0D(6)	67	5	36
DI0D(7)	34	6	34
REQ1	2	33	24
ACK1	3	27	18
STOPTRIG1	4	29	20
PCLK1	5	31	22
REQ2	9	24	32
ACK2	8	18	26
STOPTRIG2	7	20	28
PCLK2	6	22	30
CPULL	40	Not connected	14
DPULL ⁵	38	Not connected	16

Notes:

1. This is the same pinout as DIO-32F boards from National Instruments.
2. Pins 2, 4, 6, 8, 10, and 12 on the SCXI module connector are not connected.
3. RGND pins are connected to GND pins on the DAQDIO 6533 and on the adapter board. However, the shielded cable does not connect these four pins from the DAQDIO 6533 to the adapter.
4. DIOA(0) on the SCXI module connector is tied to +5 V with a 100 k Ω resistor on the adapter board. This pin connects directly to DIOA(0) of the breakout and DAQDIO 6533 connectors when you set SW1 for parallel mode. When you set SW1 for serial mode, the adapter board inserts a buffer to redrive the module connector pin to the breakout connector and DAQDIO 6533 connector.
5. DPULL is tied to +5 V with a 470 Ω resistor on the adapter board.



321538A-01

Apr97