

## COMPREHENSIVE SERVICES

We offer competitive repair and calibration services, as well as easily accessible documentation and free downloadable resources.

## SELL YOUR SURPLUS

We buy new, used, decommissioned, and surplus parts from every NI series. We work out the best solution to suit your individual needs.

 Sell For Cash    Get Credit    Receive a Trade-In Deal

## OBSOLETE NI HARDWARE IN STOCK & READY TO SHIP

We stock **New**, **New Surplus**, **Refurbished**, and **Reconditioned** NI Hardware.



*Bridging the gap between the manufacturer and your legacy test system.*

 1-800-915-6216

 [www.apexwaves.com](http://www.apexwaves.com)

 [sales@apexwaves.com](mailto:sales@apexwaves.com)

*All trademarks, brands, and brand names are the property of their respective owners.*

**Request a Quote**

 **CLICK HERE**

**AT-MIO-16X**

---

## SCXI-1345 Shielded Cable

This guide describes how to install the SCXI-1345 shielded cable with an adapter board between an SCXI module and a data acquisition board. In addition to the SCXI-1345 kit contents, you will also need an SCXI chassis, an SCXI module, a computer, a multifunction I/O (MIO) board, a small Phillips-head screwdriver, and a small flathead screwdriver.

### Introduction

With the SCXI-1345 shielded cable, you can make a low-noise, long-distance connection between your SCXI chassis and your MIO board. You can use the SCXI-1345 with the following MIO boards:

<b>PC/XT, PC AT</b>	<b>Macintosh</b>
AT-MIO-16 AT-MIO-16F-5 AT-MIO-16X	NB-MIO-16 NB-MIO-16X

The SCXI-1345 shielded cable consists of a 1, 2, 5, or 10 m round cable that has a 50-pin female connector with a grounding strap at one end and a 68-pin female connector at the other end. When plugged into the SCXI-1345 adapter board, the shielded cable brings the pinout of the MIO board I/O connector to the SCXI module and to a breakout connector you can use with other SCXI accessories, such as the SCXI-1180 and the SCXI-1351.

### What Your Kit Should Contain

The SCXI-1345 shielded cable kit is available in four cable sizes: 1, 2, 5, or 10 m.

In addition, each version of the kit contains the following components:

- Cable adapter assembly
- Two small screws
- Replacement bracket for AT-MIO-16 boards

- Replacement bracket for NB-MIO-16 boards
- Two cable tie wraps
- *SCXI-1345 Shielded Cable Installation Guide*

If your kit is missing any of the components, contact National Instruments.

## Installation Procedure

Figure 1 illustrates the components of your SCXI system and how to connect them.

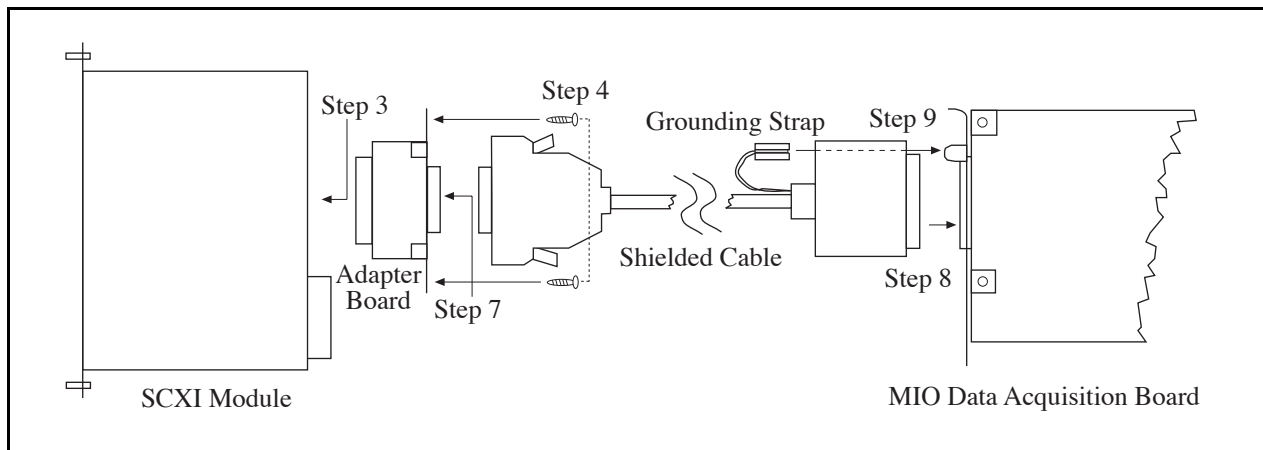

Figure 1. Connecting the SCXI-1345 to Your MIO Board and SCXI Module

Perform the following steps to install the SCXI-1345 cable:

1. Turn off the power to your computer and the SCXI chassis.
2. Install your SCXI module in the SCXI chassis, following the instructions in your module user manual.
3. Plug the socket connector of the SCXI-1345 adapter board into the rear signal connector of the SCXI module.
4. Secure the SCXI-1345 adapter board by screwing the two screws through the rear panel of the adapter board and into the threaded strips in the rear of the SCXI chassis.

5. Replace the bracket of your MIO board with the appropriate bracket from the SCXI-1345 cable kit, unless your MIO board has a bracket with a grounding strap tab.
  - a. Remove your MIO board from your computer.
  - b. Unscrew and remove the two screws that attach the bracket to the MIO board.
  - c. Remove the bracket from the board. See Figure 2 for NB board bracket removal or Figure 3 for AT board bracket removal.

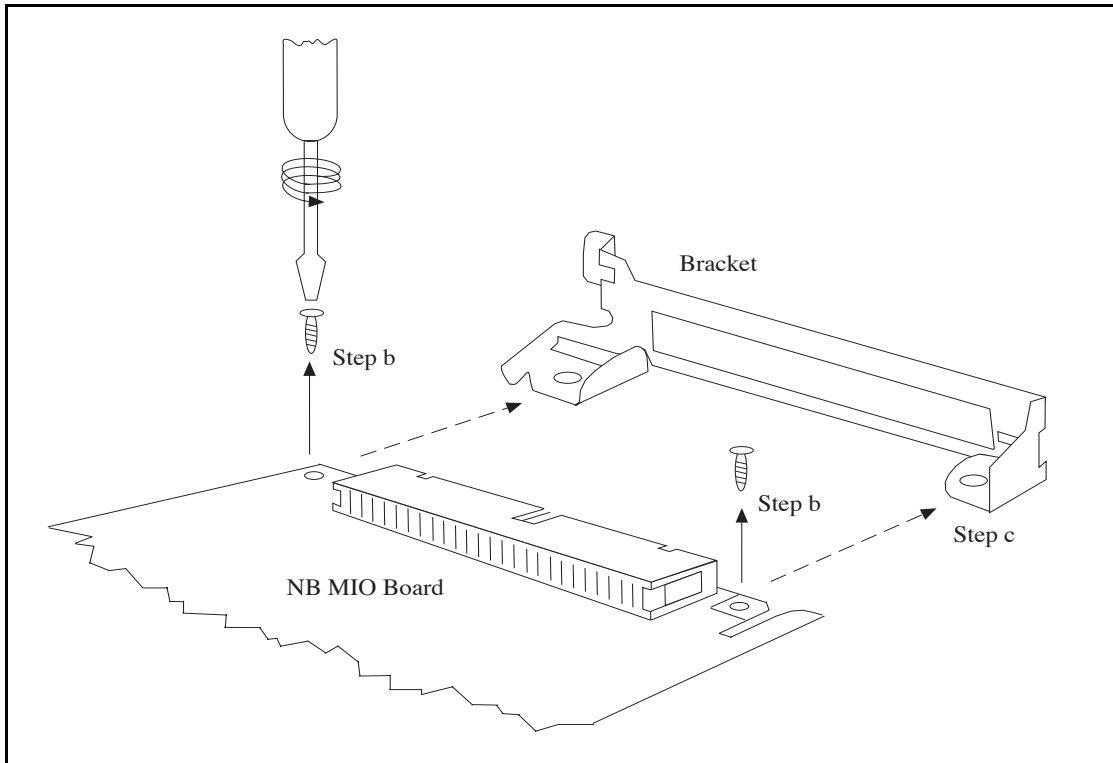

Figure 2. Removing the Bracket from an NB Board

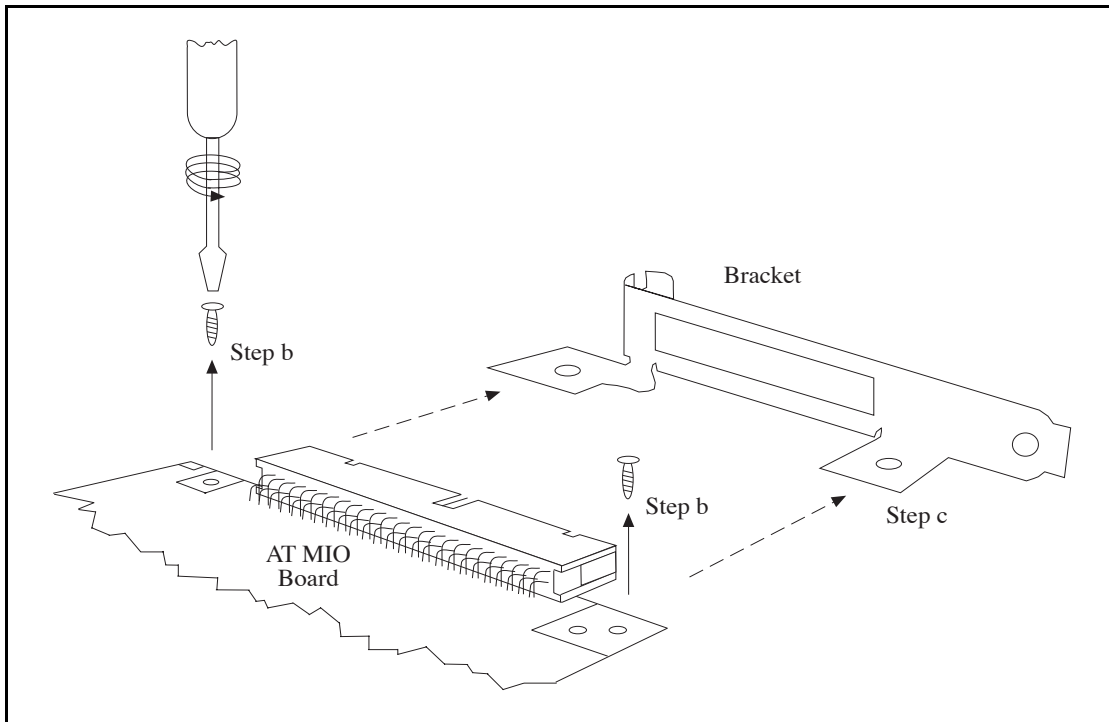

Figure 3. Removing the Bracket from an AT Board

- d. The 50-position I/O connector on your MIO board may have small plastic key inserts installed for mating with military polarized connectors. Because these keys are not compatible with the 50-position connector on the SCXI-1345, you must remove them. The 50-position SCXI-1345 connector has a center polarization bump that prevents you from inserting the connector upside down.

To remove the key inserts, use a thin probe such as a pencil or pen tip to gently press down on the release tab in the center of the key insert (see Figure 4). Then use the probe to lift up the back end of the key insert and slide the insert off the connector.

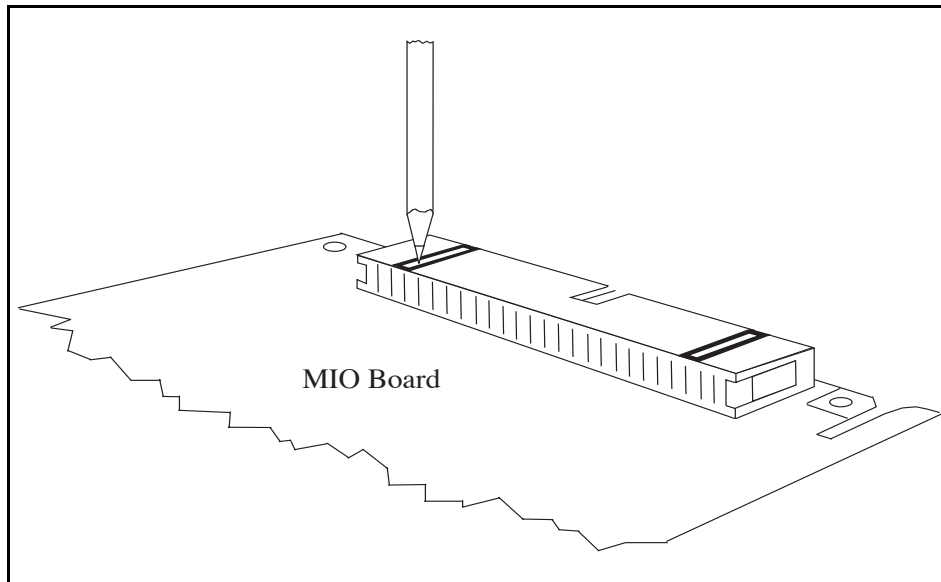

Figure 4. Removing the Key Inserts

- e. Identify the proper replacement bracket from your kit. If you have an NB Series board, use the bracket marked 745402-01; if you have an AT Series board, use the bracket marked 745403-01. The bracket that you use should look like the one you remove, except that the new one has an extra tab that attaches to the grounding strap.
  - f. Install the new bracket by aligning the bracket with the holes in your MIO board and screw in the two mounting screws.
6. Install your MIO board in a slot in your computer, following the instructions in your MIO board user manual.
  7. Connect the 68-pin connector (the end without the grounding strap) of the SCXI-1345 cable to the 68-pin connector of the SCXI-1345 adapter board as shown in Figure 5.

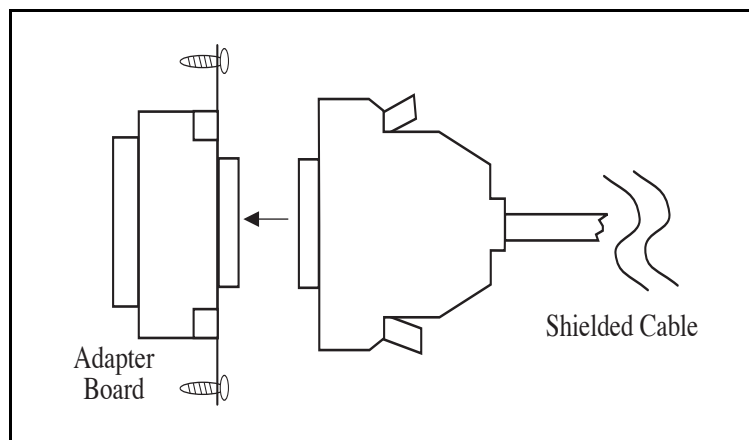

Figure 5. Cable to Adapter Board Connection

8. Connect the 50-pin connector (the end with the grounding strap) of the cable to the I/O connector on the MIO board as shown in Figure 6.

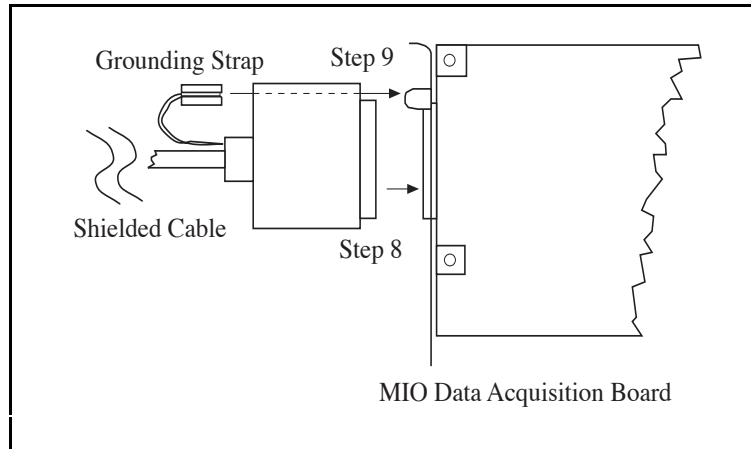

Figure 6. Cable to I/O Connector Connection

9. Slide the end lug of the ground strap onto the tab of the MIO bracket.
10. Secure the cable to a fixed object with the tie wraps to relieve the strain on the cable. Strain relief is needed because the SCXI-1345 shielded cable is considerably stiffer than ribbon cable. The cable connector also has a long stiff backshell that can exert leverage on the MIO board connector.

The finished installation should look like Figure 7.

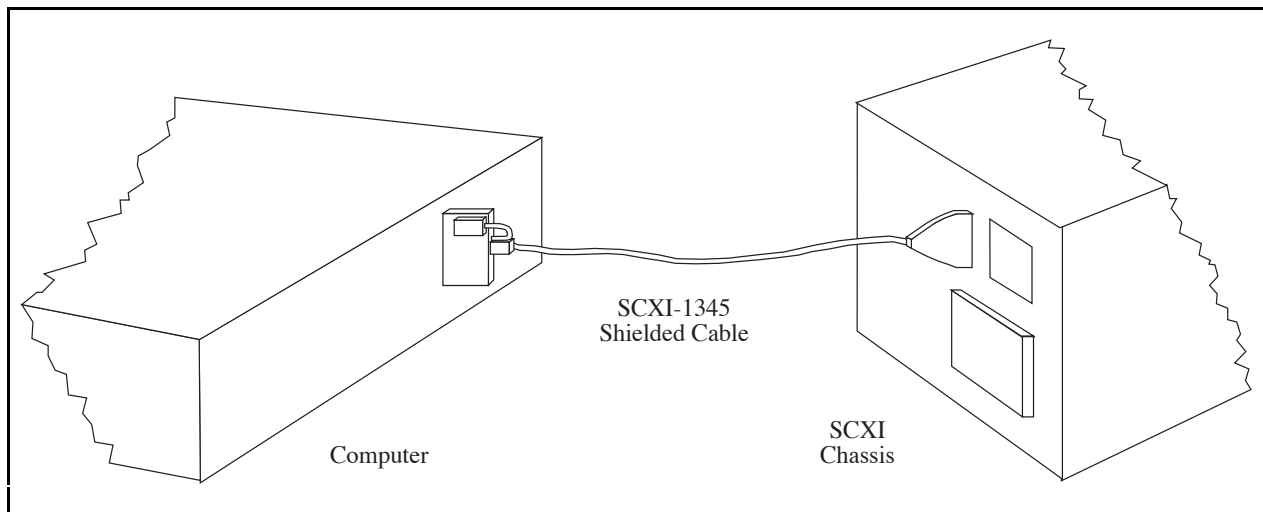

Figure 7. Installed Cable

## **Grounding Considerations**

The SCXI-1345 cable has an outer shield, which is grounded to the SCXI chassis at one end when you connect the SCXI-1345 cable to the chassis. The other end of the cable terminates in a grounding strap that provides shielding for the MIO board when connected. You do not have to connect the grounding strap for the system to function; however, connecting the grounding strap improves the electrostatic discharge immunity of the SCXI system, reduces electromagnetic interference, and shields the analog signals from noise. National Instruments recommends that you connect the grounding strap. On the other hand, connecting the grounding strap may increase the ground current flowing between the SCXI system and the computer, thus increasing the noise in some applications. Laboratory tests with the grounding strap connected produced less noise, but you can try it both ways and decide which way works better for your application. If you leave the grounding strap unconnected, secure it to the cable with a tie wrap so that the strap does not dangle and brush against the exposed pins of another connector at the back of your computer.

## **SCXI-1345 Shielded Cable Assembly Pin Translations**

The SCXI-1345 cable assembly ties pins 1 and 2 (AIGND) of the MIO board I/O connector together and ties pins 24 and 33 (DGND) of the MIO board I/O connector together. Do not use the SCXI-1345 cable assembly with any data acquisition board other than an MIO-16. All other numbered pins only connect to the same pin number on all three connectors.