

COMPREHENSIVE SERVICES

We offer competitive repair and calibration services, as well as easily accessible documentation and free downloadable resources.

SELL YOUR SURPLUS

We buy new, used, decommissioned, and surplus parts from every NI series. We work out the best solution to suit your individual needs.

 Sell For Cash  Get Credit  Receive a Trade-In Deal

OBSOLETE NI HARDWARE IN STOCK & READY TO SHIP

We stock **New**, **New Surplus**, **Refurbished**, and **Reconditioned** NI Hardware.



Bridging the gap between the manufacturer and your legacy test system.

 1-800-915-6216

 www.apexwaves.com

 sales@apexwaves.com

All trademarks, brands, and brand names are the property of their respective owners.

Request a Quote

 **CLICK HERE**

CA-1000

DAQ M Series

M Series User Manual

*NI 622x, NI 625x, and NI 628x Multifunction I/O
Modules and Devices*

Worldwide Technical Support and Product Information

ni.com

Worldwide Offices

Visit ni.com/niglobal to access the branch office websites, which provide up-to-date contact information, support phone numbers, email addresses, and current events.

National Instruments Corporate Headquarters

11500 North Mopac Expressway Austin, Texas 78759-3504 USA Tel: 512 683 0100

For further support information, refer to the *NI Services* appendix. To comment on NI documentation, refer to the NI website at ni.com/info and enter the Info Code `feedback`.

© 2004–2016 National Instruments. All rights reserved.

Legal Information

Limited Warranty

This document is provided 'as is' and is subject to being changed, without notice, in future editions. For the latest version, refer to ni.com/manuals. NI reviews this document carefully for technical accuracy; however, NI MAKES NO EXPRESS OR IMPLIED WARRANTIES AS TO THE ACCURACY OF THE INFORMATION CONTAINED HEREIN AND SHALL NOT BE LIABLE FOR ANY ERRORS.

NI warrants that its hardware products will be free of defects in materials and workmanship that cause the product to fail to substantially conform to the applicable NI published specifications for one (1) year from the date of invoice.

For a period of ninety (90) days from the date of invoice, NI warrants that (i) its software products will perform substantially in accordance with the applicable documentation provided with the software and (ii) the software media will be free from defects in materials and workmanship.

If NI receives notice of a defect or non-conformance during the applicable warranty period, NI will, in its discretion: (i) repair or replace the affected product, or (ii) refund the fees paid for the affected product. Repaired or replaced Hardware will be warranted for the remainder of the original warranty period or ninety (90) days, whichever is longer. If NI elects to repair or replace the product, NI may use new or refurbished parts or products that are equivalent to new in performance and reliability and are at least functionally equivalent to the original part or product.

You must obtain an RMA number from NI before returning any product to NI. NI reserves the right to charge a fee for examining and testing Hardware not covered by the Limited Warranty.

This Limited Warranty does not apply if the defect of the product resulted from improper or inadequate maintenance, installation, repair, or calibration (performed by a party other than NI); unauthorized modification; improper environment; use of an improper hardware or software key; improper use or operation outside of the specification for the product; improper voltages; accident, abuse, or neglect; or a hazard such as lightning, flood, or other act of nature.

THE REMEDIES SET FORTH ABOVE ARE EXCLUSIVE AND THE CUSTOMER'S SOLE REMEDIES, AND SHALL APPLY EVEN IF SUCH REMEDIES FAIL OF THEIR ESSENTIAL PURPOSE.

EXCEPT AS EXPRESSLY SET FORTH HEREIN, PRODUCTS ARE PROVIDED "AS IS" WITHOUT WARRANTY OF ANY KIND AND NI DISCLAIMS ALL WARRANTIES, EXPRESSED OR IMPLIED, WITH RESPECT TO THE PRODUCTS, INCLUDING ANY IMPLIED WARRANTIES OF MERCHANTABILITY, FITNESS FOR A PARTICULAR PURPOSE, TITLE OR NON-INFRINGEMENT, AND ANY WARRANTIES THAT MAY ARISE FROM USAGE OF TRADE OR COURSE OF DEALING. NI DOES NOT WARRANT, GUARANTEE, OR MAKE ANY REPRESENTATIONS REGARDING THE USE OF OR THE RESULTS OF THE USE OF THE PRODUCTS IN TERMS OF CORRECTNESS, ACCURACY, RELIABILITY, OR OTHERWISE. NI DOES NOT WARRANT THAT THE OPERATION OF THE PRODUCTS WILL BE UNINTERRUPTED OR ERROR FREE.

In the event that you and NI have a separate signed written agreement with warranty terms covering the products, then the warranty terms in the separate agreement shall control.

Copyright

Under the copyright laws, this publication may not be reproduced or transmitted in any form, electronic or mechanical, including photocopying, recording, storing in an information retrieval system, or translating, in whole or in part, without the prior written consent of National Instruments Corporation.

National Instruments respects the intellectual property of others, and we ask our users to do the same. NI software is protected by copyright and other intellectual property laws. Where NI software may be used to reproduce software or other materials belonging to others, you may use NI software only to reproduce materials that you may reproduce in accordance with the terms of any applicable license or other legal restriction.

End-User License Agreements and Third-Party Legal Notices

You can find end-user license agreements (EULAs) and third-party legal notices in the following locations:

- Notices are located in the <National Instruments>_Legal Information and <National Instruments> directories.
- EULAs are located in the <National Instruments>\Shared\MDF\Legal\license directory.
- Review <National Instruments>_Legal Information.txt for information on including legal information in installers built with NI products.

U.S. Government Restricted Rights

If you are an agency, department, or other entity of the United States Government ("Government"), the use, duplication, reproduction, release, modification, disclosure or transfer of the technical data included in this manual is governed by the Restricted Rights provisions under Federal Acquisition Regulation 52.227-14 for civilian agencies and Defense Federal Acquisition Regulation Supplement Section 252.227-7014 and 252.227-7015 for military agencies.

Trademarks

Refer to the *NI Trademarks and Logo Guidelines* at ni.com/trademarks for more information on NI trademarks.

ARM, Keil, and μ Vision are trademarks or registered of ARM Ltd or its subsidiaries.

LEGO, the LEGO logo, WEDO, and MINDSTORMS are trademarks of the LEGO Group.

TETRIX by Pitsco is a trademark of Pitsco, Inc.

FIELDBUS FOUNDATION™ and FOUNDATION™ are trademarks of the Fieldbus Foundation.

EtherCAT® is a registered trademark of and licensed by Beckhoff Automation GmbH.

CANopen® is a registered Community Trademark of CAN in Automation e.V.

DeviceNet™ and EtherNet/IP™ are trademarks of ODVA.

Go!, SensorDAQ, and Vernier are registered trademarks of Vernier Software & Technology. Vernier Software & Technology and vernier.com are trademarks or trade dress.

Xilinx is the registered trademark of Xilinx, Inc.

Taptite and Trilobular are registered trademarks of Research Engineering & Manufacturing Inc.

FireWire® is the registered trademark of Apple Inc.

Linux® is the registered trademark of Linus Torvalds in the U.S. and other countries.

Handle Graphics®, MATLAB®, Simulink®, Stateflow®, and xPC TargetBox® are registered trademarks, and Simulink Coder™, TargetBox™, and Target Language Compiler™ are trademarks of The MathWorks, Inc.

Tektronix®, Tek, and Tektronix, Enabling Technology are registered trademarks of Tektronix, Inc.

The Bluetooth® word mark is a registered trademark owned by the Bluetooth SIG, Inc.

The ExpressCard™ word mark and logos are owned by PCMCIA and any use of such marks by National Instruments is under license.

The mark LabWindows is used under a license from Microsoft Corporation. Windows is a registered trademark of Microsoft Corporation in the United States and other countries.

Other product and company names mentioned herein are trademarks or trade names of their respective companies.

Members of the National Instruments Alliance Partner Program are business entities independent from NI and have no agency, partnership, or joint-venture relationship with NI.

Patents

For patents covering NI products/technology, refer to the appropriate location: **Help»Patents** in your software, the `patents.txt` file on your media, or the *National Instruments Patent Notice* at ni.com/patents.

Export Compliance Information

Refer to the *Export Compliance Information* at ni.com/legal/export-compliance for the NI global trade compliance policy and how to obtain relevant HTS codes, ECCNs, and other import/export data.

WARNING REGARDING USE OF NATIONAL INSTRUMENTS PRODUCTS

YOU ARE ULTIMATELY RESPONSIBLE FOR VERIFYING AND VALIDATING THE SUITABILITY AND RELIABILITY OF THE PRODUCTS WHENEVER THE PRODUCTS ARE INCORPORATED IN YOUR SYSTEM OR APPLICATION, INCLUDING THE APPROPRIATE DESIGN, PROCESS, AND SAFETY LEVEL OF SUCH SYSTEM OR APPLICATION.

PRODUCTS ARE NOT DESIGNED, MANUFACTURED, OR TESTED FOR USE IN LIFE OR SAFETY CRITICAL SYSTEMS, HAZARDOUS ENVIRONMENTS OR ANY OTHER ENVIRONMENTS REQUIRING FAIL-SAFE PERFORMANCE, INCLUDING IN THE OPERATION OF NUCLEAR FACILITIES; AIRCRAFT NAVIGATION; AIR TRAFFIC CONTROL SYSTEMS; LIFE SAVING OR LIFE SUSTAINING SYSTEMS OR SUCH OTHER MEDICAL DEVICES; OR ANY OTHER APPLICATION IN WHICH THE FAILURE OF THE PRODUCT OR SERVICE COULD LEAD TO DEATH, PERSONAL INJURY, SEVERE PROPERTY DAMAGE OR ENVIRONMENTAL HARM (COLLECTIVELY, "HIGH-RISK USES"). FURTHER, PRUDENT STEPS MUST BE TAKEN TO PROTECT AGAINST FAILURES, INCLUDING PROVIDING BACK-UP AND SHUT-DOWN MECHANISMS. NI EXPRESSLY DISCLAIMS ANY EXPRESS OR IMPLIED WARRANTY OF FITNESS OF THE PRODUCTS OR SERVICES FOR HIGH-RISK USES.

Contents

Chapter 1

Getting Started

Safety Guidelines.....	1-1
Safety Guidelines for Hazardous Voltages.....	1-2
Electromagnetic Compatibility Guidelines.....	1-2
Hardware Symbol Definitions.....	1-3
Installation.....	1-3
Unpacking.....	1-3
Device Self-Calibration.....	1-4
Getting Started with M Series PCI Express Devices and the Disk Drive Power Connector.....	1-5
When to Use the Disk Drive Power Connector.....	1-5
Disk Drive Power Connector Installation.....	1-5
Getting Started with M Series USB Devices.....	1-6
Applying the Signal Label to USB Screw Terminal Devices.....	1-6
USB Device Chassis Ground.....	1-6
USB Device Panel/Wall Mounting.....	1-8
USB Device LEDs.....	1-8
USB Cable Strain Relief.....	1-8
USB Device Fuse Replacement.....	1-9
USB Device Security Cable Slot.....	1-12
Installing a Ferrite.....	1-13
Pinouts.....	1-13
Specifications.....	1-13
Accessories and Cables.....	1-13

Chapter 2

DAQ System Overview

DAQ Hardware.....	2-1
DAQ-STC2 and DAQ-6202.....	2-2
Calibration Circuitry.....	2-2
Cables and Accessories.....	2-3
68-Pin M Series Cables and Accessories.....	2-3
68-Pin Cables.....	2-5
68-Pin BNC Accessories.....	2-6
68-Pin Screw Terminal Accessories.....	2-6
RTSI Cables.....	2-6
SCC Carriers and Accessories.....	2-6
SCXI.....	2-7
68-Pin Custom Cabling and Connectivity.....	2-7
USB Device Accessories, USB Cable, and Power Supply.....	2-8

37-Pin M Series Cables and Accessories.....	2-8
37-Pin Cables.....	2-9
37-Pin Screw Terminal Accessories.....	2-9
RTSI Cables.....	2-9
37-Pin Custom Cabling.....	2-9
Signal Conditioning.....	2-10
Sensors and Transducers.....	2-10
Signal Conditioning Options.....	2-10
SCXI.....	2-10
SCC.....	2-11
Programming Devices in Software.....	2-11

Chapter 3 Connector and LED Information

I/O Connector Signal Descriptions.....	3-1
+5 V Power Source.....	3-5
USER 1 and USER 2.....	3-5
RTSI Connector Pinout.....	3-7
LED Patterns.....	3-7

Chapter 4 Analog Input

Analog Input Range.....	4-2
Analog Input Lowpass Filter.....	4-3
Analog Input Ground-Reference Settings.....	4-4
Configuring AI Ground-Reference Settings in Software.....	4-6
Multichannel Scanning Considerations.....	4-6
Analog Input Data Acquisition Methods.....	4-9
Software-Timed Acquisitions.....	4-9
Hardware-Timed Acquisitions.....	4-9
Analog Input Triggering.....	4-10
Connecting Analog Input Signals.....	4-11
Connecting Floating Signal Sources.....	4-12
What Are Floating Signal Sources?.....	4-12
When to Use Differential Connections with Floating Signal Sources.....	4-12
When to Use Non-Referenced Single-Ended (NRSE) Connections with Floating Signal Sources.....	4-12
When to Use Referenced Single-Ended (RSE) Connections with Floating Signal Sources.....	4-13
Using Differential Connections for Floating Signal Sources.....	4-13
Using Non-Referenced Single-Ended (NRSE) Connections for Floating Signal Sources.....	4-16
Using Referenced Single-Ended (RSE) Connections for Floating Signal Sources.....	4-17

Connecting Ground-Referenced Signal Sources	4-17
What Are Ground-Referenced Signal Sources?	4-17
When to Use Differential Connections with Ground-Referenced Signal Sources	4-18
When to Use Non-Referenced Single-Ended (NRSE) Connections with Ground-Referenced Signal Sources	4-18
When to Use Referenced Single-Ended (RSE) Connections with Ground-Referenced Signal Sources	4-19
Using Differential Connections for Ground-Referenced Signal Sources	4-19
Using Non-Referenced Single-Ended (NRSE) Connections for Ground-Referenced Signal Sources	4-20
Field Wiring Considerations	4-21
Analog Input Timing Signals	4-21
AI Sample Clock Signal	4-23
Using an Internal Source	4-24
Using an External Source	4-24
Routing AI Sample Clock Signal to an Output Terminal	4-24
Other Timing Requirements	4-24
AI Sample Clock Timebase Signal	4-25
AI Convert Clock Signal	4-25
Using an Internal Source	4-26
Using an External Source	4-26
Routing AI Convert Clock Signal to an Output Terminal	4-26
Using a Delay from Sample Clock to Convert Clock	4-27
Other Timing Requirements	4-27
AI Convert Clock Timebase Signal	4-29
AI Hold Complete Event Signal	4-29
AI Start Trigger Signal	4-29
Using a Digital Source	4-29
Using an Analog Source	4-30
Routing AI Start Trigger to an Output Terminal	4-30
AI Reference Trigger Signal	4-30
Using a Digital Source	4-31
Using an Analog Source	4-31
Routing AI Reference Trigger Signal to an Output Terminal	4-31
AI Pause Trigger Signal	4-31
Using a Digital Source	4-32
Using an Analog Source	4-32
Routing AI Pause Trigger Signal to an Output Terminal	4-32
Getting Started with AI Applications in Software	4-32

Chapter 5

Analog Output

AO Offset and AO Reference Selection	5-2
Minimizing Glitches on the Output Signal	5-3
Analog Output Data Generation Methods	5-3
Software-Timed Generations	5-3
Hardware-Timed Generations	5-4
Analog Output Triggering	5-5
Connecting Analog Output Signals	5-5
Analog Output Timing Signals	5-6
AO Start Trigger Signal	5-6
Using a Digital Source	5-6
Using an Analog Source	5-7
Routing AO Start Trigger Signal to an Output Terminal	5-7
AO Pause Trigger Signal	5-7
Using a Digital Source	5-8
Using an Analog Source	5-8
Routing AO Pause Trigger Signal to an Output Terminal	5-8
AO Sample Clock Signal	5-8
Using an Internal Source	5-8
Using an External Source	5-8
Routing AO Sample Clock Signal to an Output Terminal	5-9
Other Timing Requirements	5-9
AO Sample Clock Timebase Signal	5-9
Getting Started with AO Applications in Software	5-10

Chapter 6

Digital I/O

Static DIO	6-2
Digital Waveform Triggering	6-2
Digital Waveform Acquisition	6-3
DI Sample Clock Signal	6-3
Using an Internal Source	6-3
Using an External Source	6-4
Routing DI Sample Clock to an Output Terminal	6-4
Digital Waveform Generation	6-4
DO Sample Clock Signal	6-4
Using an Internal Source	6-5
Using an External Source	6-5
Routing DO Sample Clock to an Output Terminal	6-5
I/O Protection	6-5
Programmable Power-Up States	6-6
DI Change Detection	6-7
DI Change Detection Applications	6-8

Connecting Digital I/O Signals.....	6-8
Getting Started with DIO Applications in Software.....	6-9

Chapter 7

Counters

Counter Input Applications	7-1
Counting Edges.....	7-2
Single Point (On-Demand) Edge Counting.....	7-2
Buffered (Sample Clock) Edge Counting.....	7-3
Controlling the Direction of Counting.....	7-3
Pulse-Width Measurement	7-3
Single Pulse-Width Measurement	7-4
Buffered Pulse-Width Measurement	7-4
Period Measurement	7-5
Single Period Measurement.....	7-5
Buffered Period Measurement.....	7-6
Semi-Period Measurement	7-7
Single Semi-Period Measurement	7-7
Buffered Semi-Period Measurement	7-7
Frequency Measurement.....	7-8
Low Frequency with One Counter	7-8
Low Frequency with One Counter (Averaged).....	7-9
High Frequency with Two Counters	7-9
Large Range of Frequencies with Two Counters	7-10
Choosing a Method for Measuring Frequency	7-11
Position Measurement	7-14
Measurements Using Quadrature Encoders	7-15
Measurements Using Two Pulse Encoders	7-16
Buffered (Sample Clock) Position Measurement.....	7-17
Two-Signal Edge-Separation Measurement.....	7-17
Single Two-Signal Edge-Separation Measurement.....	7-18
Buffered Two-Signal Edge-Separation Measurement.....	7-18
Counter Output Applications.....	7-19
Simple Pulse Generation	7-19
Single Pulse Generation.....	7-19
Single Pulse Generation with Start Trigger.....	7-20
Retriggerable Single Pulse Generation.....	7-20
Pulse Train Generation	7-21
Continuous Pulse Train Generation.....	7-21
Finite Pulse Train Generation.....	7-22
Frequency Generation.....	7-22
Using the Frequency Generator.....	7-22
Frequency Division.....	7-23
Pulse Generation for ETS	7-23

Counter Timing Signals	7-24
Counter <i>n</i> Source Signal	7-24
Routing a Signal to Counter <i>n</i> Source	7-25
Routing Counter <i>n</i> Source to an Output Terminal	7-25
Counter <i>n</i> Gate Signal	7-25
Routing a Signal to Counter <i>n</i> Gate	7-26
Routing Counter <i>n</i> Gate to an Output Terminal	7-26
Counter <i>n</i> Aux Signal	7-26
Routing a Signal to Counter <i>n</i> Aux	7-26
Counter <i>n</i> A, Counter <i>n</i> B, and Counter <i>n</i> Z Signals	7-27
Routing Signals to A, B, and Z Counter Inputs	7-27
Routing Counter <i>n</i> Z Signal to an Output Terminal	7-27
Counter <i>n</i> Up_Down Signal	7-27
Counter <i>n</i> HW Arm Signal	7-27
Routing Signals to Counter <i>n</i> HW Arm Input	7-27
Counter <i>n</i> Internal Output and Counter <i>n</i> TC Signals	7-28
Routing Counter <i>n</i> Internal Output to an Output Terminal	7-28
Frequency Output Signal	7-28
Routing Frequency Output to a Terminal	7-28
Default Counter/Timer Pinouts	7-28
Counter Triggering	7-29
Other Counter Features	7-30
Cascading Counters	7-30
Counter Filters	7-30
Prescaling	7-32
Duplicate Count Prevention	7-32
Example Application That Works Correctly (No Duplicate Counting)	7-33
Example Application That Works Incorrectly (Duplicate Counting)	7-33
Example Application That Prevents Duplicate Count	7-34
When To Use Duplicate Count Prevention	7-34
Enabling Duplicate Count Prevention in NI-DAQmx	7-35
Synchronization Modes	7-35
80 MHz Source Mode	7-36
Other Internal Source Mode	7-36
External Source Mode	7-36

Chapter 8

PFI

Using PFI Terminals as Timing Input Signals	8-2
Exporting Timing Output Signals Using PFI Terminals	8-2
Using PFI Terminals as Static Digital I/Os	8-3
Connecting PFI Input Signals	8-3
PFI Filters	8-4
I/O Protection	8-5
Programmable Power-Up States	8-5

Chapter 9

Digital Routing and Clock Generation

Clock Routing.....	9-1
80 MHz Timebase	9-2
20 MHz Timebase	9-2
100 kHz Timebase	9-2
External Reference Clock	9-2
10 MHz Reference Clock	9-2
Synchronizing Multiple Devices	9-3
PXI/PXI Express Modules.....	9-3
PCI/PCI Express Devices	9-3
USB Devices.....	9-3
Real-Time System Integration (RTSI)	9-4
RTSI Connector Pinout	9-4
Using RTSI as Outputs	9-5
Using RTSI Terminals as Timing Input Signals	9-6
RTSI Filters	9-6
PXI Clock and Trigger Signals.....	9-8
PXI_CLK10.....	9-8
PXI Triggers	9-8
PXI_STAR Trigger.....	9-8
PXI_STAR Filters	9-8

Chapter 10

Bus Interface

Data Transfer Methods	10-1
PCI/PCI Express Device and PXI/PXI Express Module Data Transfer Methods....	10-1
USB Device Data Transfer Methods	10-2
PXI Considerations.....	10-3
PXI Clock and Trigger Signals.....	10-3
PXI and PXI Express.....	10-3
Using PXI with CompactPCI	10-4

Chapter 11

Triggering

Triggering with a Digital Source	11-1
Triggering with an Analog Source	11-2
APFI <0,1> Terminals.....	11-2
Analog Input Channels	11-2
Analog Trigger Actions	11-3
Routing Analog Comparison Event to an Output Terminal	11-3
Analog Trigger Types.....	11-3
Analog Trigger Accuracy	11-6

Appendix A

Module/Device-Specific Information

NI 6220	A-2
NI 6221 (68-Pin)	A-4
NI PCI-6221 (37-Pin)	A-11
NI 6224	A-13
NI 6225	A-15
NI 6229	A-21
NI 6250	A-27
NI 6251	A-29
NI 6254	A-37
NI 6255	A-39
NI 6259	A-45
NI 6280	A-53
NI 6281	A-55
NI 6284	A-61
NI 6289	A-63

Appendix B

Timing Diagrams

Appendix C

Troubleshooting

Appendix D

Upgrading from E Series to M Series

Appendix E

Where to Go from Here

Appendix F

NI Services

Index

Figures

Figure A-1.	PCI/PXI-6220 Pinout	A-2
Figure A-2.	PCI/PXI-6221 Pinout	A-5
Figure A-3.	USB-6221 Screw Terminal Pinout.....	A-7
Figure A-4.	USB-6221 BNC Top Panel and Pinout	A-9
Figure A-5.	PCI-6221 (37-Pin) Pinout.....	A-11
Figure A-6.	PCI/PXI-6224 Pinout	A-13
Figure A-7.	PCI/PXI-6225 Pinout	A-15
Figure A-8.	USB-6225 Screw Terminal Pinout.....	A-17
Figure A-9.	USB-6225 Mass Termination Pinout	A-19
Figure A-10.	PCI/PXI-6229 Pinout	A-21
Figure A-11.	USB-6229 Screw Terminal Pinout.....	A-23
Figure A-12.	USB-6229 BNC Top Panel and Pinout	A-25
Figure A-13.	PCI/PXI-6250 Pinout	A-27
Figure A-14.	NI PCI/PCIe/PXI/PXIe-6251 Pinout.....	A-29
Figure A-15.	USB-6251 Screw Terminal Pinout.....	A-31
Figure A-16.	USB-6251 BNC Top Panel and Pinout	A-33
Figure A-17.	USB-6251 Mass Termination Pinout	A-35
Figure A-18.	PCI/PXI-6254 Pinout	A-37
Figure A-19.	PCI/PXI-6255 Pinout	A-39
Figure A-20.	USB-6255 Screw Terminal Pinout.....	A-41
Figure A-21.	USB-6255 Mass Termination Pinout	A-43
Figure A-22.	NI PCI/PCIe/PXI/PXIe-6259 Pinout.....	A-45
Figure A-23.	USB-6259 Screw Terminal Pinout.....	A-47
Figure A-24.	USB-6259 BNC Top Panel and Pinout	A-49
Figure A-25.	USB-6259 Mass Termination Pinout	A-51
Figure A-26.	PCI/PXI-6280 Pinout	A-53
Figure A-27.	PCI/PXI-6281 Pinout	A-55
Figure A-28.	USB-6281 Screw Terminal Pinout.....	A-57
Figure A-29.	USB-6281 Mass Termination Pinout	A-59
Figure A-30.	PCI/PXI-6284 Pinout	A-61
Figure A-31.	PCI/PXI-6289 Pinout	A-63
Figure A-32.	USB-6289 Screw Terminal Pinout.....	A-65
Figure A-33.	USB-6289 Mass Termination Pinout	A-67

Getting Started

The *M Series User Manual* contains information about using the National Instruments M Series multifunction I/O data acquisition (DAQ) devices with NI-DAQmx 15.5 and later. M Series devices feature up to 80 analog input (AI) channels, up to four analog output (AO) channels, up to 48 lines of digital input/output (DIO), and two counters. This chapter provides basic information you need to get started using your M Series device.

Safety Guidelines

Operate the NI 62xx M Series devices and modules only as described in this user manual.



Caution NI 62xx devices and modules are *not* certified for use in hazardous locations.



Caution *Never* connect the +5 V power terminals to analog or digital ground or to any other voltage source on the M Series device or any other device. Doing so can damage the device and the computer. NI is not liable for damage resulting from such a connection.



Caution The maximum input voltages rating of AI signals with respect to ground (and for signal pairs in differential mode with respect to each other) are listed in the specifications document for your device. Exceeding the maximum input voltage of AI signals distorts the measurement results. Exceeding the maximum input voltage rating also can damage the device and the computer. NI is not liable for any damage resulting from such signal connections.



Caution Exceeding the maximum input voltage ratings, which are listed in the specifications document for each M Series device, can damage the DAQ device and the computer. NI is not liable for any damage resulting from such signal connections.



Caution Damage can result if these lines are driven by the sub-bus. NI is not liable for any damage resulting from improper signal connections.

Safety Guidelines for Hazardous Voltages

If *hazardous voltages* are connected to the device/module, take the following precautions. A hazardous voltage is a voltage greater than 42.4 V_{pk} or 60 VDC to earth ground.



Caution Ensure that hazardous voltage wiring is performed only by qualified personnel adhering to local electrical standards.



Caution Do *not* mix hazardous voltage circuits and human-accessible circuits on the same module.



Caution Make sure that chassis and circuits connected to the module are properly insulated from human contact.



Caution NI 62xx devices and modules provide no isolation.

Electromagnetic Compatibility Guidelines

This product was tested and complies with the regulatory requirements and limits for electromagnetic compatibility (EMC) as stated in the product specifications. These requirements and limits are designed to provide reasonable protection against harmful interference when the product is operated in its intended operational electromagnetic environment.

This product is intended for use in industrial locations. There is no guarantee that harmful interference will not occur in a particular installation, when the product is connected to a test object, or if the product is used in residential areas. To minimize the potential for the product to cause interference to radio and television reception or to experience unacceptable performance degradation, install and use this product in strict accordance with the instructions in the product documentation.

Furthermore, any changes or modifications to the product not expressly approved by National Instruments could void your authority to operate it under your local regulatory rules.



Caution To ensure the specified EMC performance, product installation requires either special considerations or user-installed, add-on devices. Refer to the product installation instructions for further information.



Caution For compliance with Electromagnetic Compatibility (EMC) requirements, this product must be operated with shielded cables and accessories. If unshielded cables or accessories are used, the EMC specifications are no longer guaranteed unless all unshielded cables and/or accessories are installed in a shielded enclosure with properly designed and shielded input/output ports.



Caution This product may become more sensitive to electromagnetic disturbances in the operational environment when test leads are attached or when connected to a test object.

Hardware Symbol Definitions

The following symbols are marked on your device or module.



Caution When this symbol is marked on a product, refer to the *Safety Guidelines* section for information about precautions to take.



EU Customers At the end of the product life cycle, all products *must* be sent to a WEEE recycling center. For more information about WEEE recycling centers, National Instruments WEEE initiatives, and compliance with WEEE Directive 2002/96/EC on Waste and Electronic Equipment, visit ni.com/environment/weee.



中国客户 National Instruments 符合中国电子信息产品中限制使用某些有害物质指令 (RoHS)。关于 National Instruments 中国 RoHS 合规性信息, 请登录 ni.com/environment/rohs_china。(For information about China RoHS compliance, go to ni.com/environment/rohs_china.)

Installation

Before installing your multifunction I/O device, you must install the software you plan to use with the device.

1. **Installing application software**—Refer to the installation instructions that accompany your software.
2. **Installing NI-DAQmx**—The *DAQ Getting Started Guide for PXI/PXI Express*, *DAQ Getting Started Guide for PCI/PCI Express*, or *DAQ Getting Started Guide for Externally Powered USB*, packaged with your device or module, and also available on ni.com/manuals, contain step-by-step instructions for installing software and hardware, configuring channels and tasks, and getting started developing an application.
3. **Installing the hardware**—Unpack your M Series device as described in the *Unpacking* section. Refer to the *DAQ Getting Started Guide for PXI/PXI Express*, *DAQ Getting Started Guide for PCI/PCI Express*, or *DAQ Getting Started Guide for Externally Powered USB* for information how to install your software and device or module. It also describes how to confirm that your device or module is operating properly, configure your device or module, run test panels, and take a measurement.

Unpacking

The M Series device ships in an antistatic package to prevent electrostatic discharge (ESD). ESD can damage several components on the device.



Caution *Never* touch the exposed pins of connectors.

To avoid ESD damage in handling the device, take the following precautions:

- Ground yourself with a grounding strap or by touching a grounded object.
- Touch the antistatic package to a metal part of your computer chassis before removing the device from the package.

Remove the device from the package and inspect it for loose components or any other signs of damage. Notify NI if the device appears damaged in any way. Do not install a damaged device in your computer or chassis.

Store the device in the antistatic package when the device is not in use.

Device Self-Calibration

NI recommends that you self-calibrate your M Series device after installation and whenever the ambient temperature changes. Self-calibration should be performed after the device has warmed up for the recommended time period. Refer to the device specifications to find your device warm-up time. This function measures the onboard reference voltage of the device and adjusts the self-calibration constants to account for any errors caused by short-term fluctuations in the environment. Disconnect all external signals when you self-calibrate a device.



Note (NI PCIe-6251/6259 Devices) Connecting or disconnecting the disk drive power connector on M Series PCI Express devices can affect the analog performance of your device. To compensate for this, NI recommends that you self-calibrate after connecting or disconnecting the disk drive power connector, as described in the [Device Self-Calibration](#) section.

You can initiate self-calibration using Measurement & Automation Explorer (MAX), by completing the following steps.

1. Launch MAX.
2. Select **My System»Devices and Interfaces»your device**.
3. Initiate self-calibration using one of the following methods:
 - Click **Self-Calibrate** in the upper right corner of MAX.
 - Right-click the name of the device in the MAX configuration tree and select **Self-Calibrate** from the drop-down menu.



Note You can also programmatically self-calibrate your device with NI-DAQmx, as described in *Device Calibration* in the *NI-DAQmx Help* or the *LabVIEW Help*.

Getting Started with M Series PCI Express Devices and the Disk Drive Power Connector

(NI PCIe-6251/6259 Devices) The disk drive power connector is a four-pin hard drive connector on PCI Express devices that, when connected, increases the current the device can supply on the +5 V terminal.

When to Use the Disk Drive Power Connector

M Series PCI Express devices without the disk drive power connector installed perform identically to other M Series devices for most applications and with most accessories. For most applications, it is not necessary to install the disk drive power connector.

However, you should install the disk drive power connector in either of the following situations:

- You need more power than listed in the device specifications
- You are using an SCC accessory without an external power supply, such as the SC-2345

Refer to the specifications document for your device for more information about PCI Express power requirements and power limits.

Disk Drive Power Connector Installation

Before installing the disk drive power connector, you must install and set up the M Series PCI Express device as described in the *DAQ Getting Started Guide for PCI/PCI Express*. Complete the following steps to install the disk drive power connector.

1. Power off and unplug the computer.
2. Remove the computer cover.
3. Attach the PC disk drive power connector to the disk drive power connector on the device, as shown in Figure 1-1.



Note The power available on the disk drive power connectors in a computer can vary. For example, consider using a disk drive power connector that is not in the same power chain as the hard drive.

Figure 1-1. Connecting to the Disk Drive Power Connector

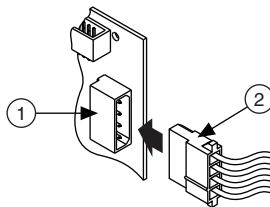

1 Device Disk Drive Power Connector

2 PC Disk Drive Power Connector

4. Replace the computer cover, and plug in and power on the computer.
5. Self-calibrate the PCI Express DAQ device in MAX by following the instructions in the [Device Self-Calibration](#) section.



Note Connecting or disconnecting the disk drive power connector can affect the analog performance of your device. To compensate for this, NI recommends that you self-calibrate after connecting or disconnecting the disk drive power connector, as described in the [Device Self-Calibration](#) section.

Getting Started with M Series USB Devices

The following sections contain information about M Series USB device features and best practices.

Applying the Signal Label to USB Screw Terminal Devices

(USB-622x/625x/628x Screw Terminal Devices) The supplied signal label can be adhered to the inside cover of the USB-62xx Screw Terminal device with supplied velcro strips as shown in Figure 1-2.

Figure 1-2. Applying the USB-62xx Screw Terminal Signal Label

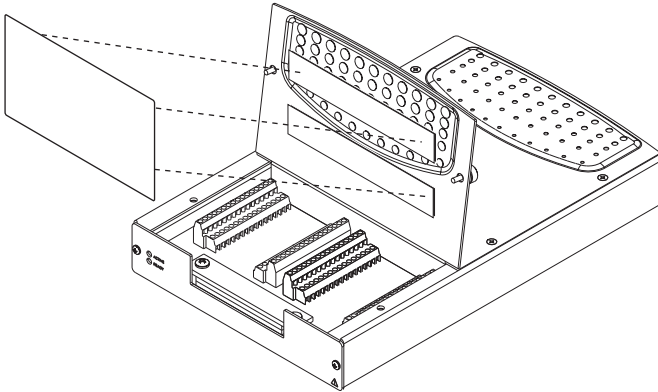

USB Device Chassis Ground

(USB-622x/625x/628x Devices) For EMC compliance, the chassis of the USB M Series device *must* be connected to earth ground through the chassis ground.

The wire should be AWG 16 or larger solid copper wire with a maximum length of 1.5 m (5 ft). Attach the wire to the earth ground of the facility's power system. For more information about earth ground connections, refer to the KnowledgeBase document, *Earth Grounding for Test and Measurement Devices*, by going to ni.com/info and entering the Info Code `earthground`.

You can attach a wire to the ground lug screw of any USB-62xx device, as shown in Figure 1-3.

Figure 1-3. Grounding a USB-62xx Device through the Ground Lug Screw

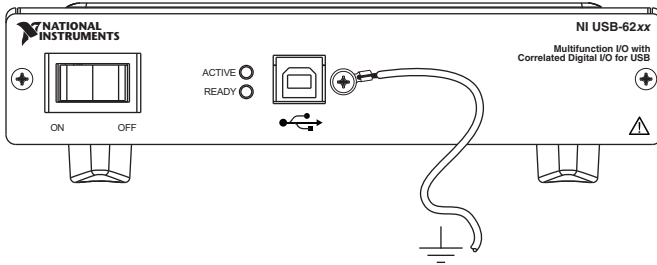

(USB-6225/625X/628X Screw Terminal Devices) You can attach and solder a wire to the chassis ground lug of certain USB-62xx Screw Terminal devices, as shown in Figure 1-4. The wire should be as short as possible.

Figure 1-4. Grounding a USB-62xx Screw Terminal Device through the Chassis Ground Lug

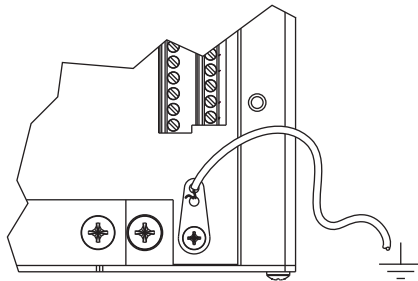

(USB-62xx BNC Devices) You can attach a wire to a CHS GND screw terminal of any USB-62xx BNC device, as shown in Figure 1-5. Use as short a wire as possible. In addition, the wires in the shielded cable that extend beyond the shield should be as short as possible.

Figure 1-5. Grounding a USB-62xx BNC Device through the CHS GND Screw Terminal

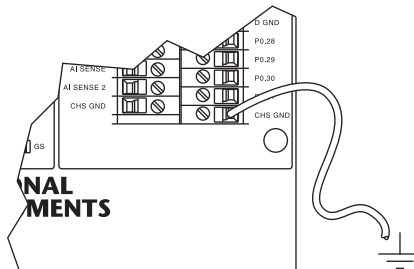

USB Device Panel/Wall Mounting

(USB-622x/625x/628x Devices) The Externally Powered USB M Series Panel Mounting Kit (part number 780214-01, not included in your USB-62xx kit) is an accessory you can use to mount the USB-62xx family of products to a panel or wall.

USB Device LEDs

(USB-622x/625x/628x Devices) Refer to the *LED Patterns* section of Chapter 3, *Connector and LED Information*, for information about the M Series USB device LEDs.

USB Cable Strain Relief

(USB-622x/625x/628x Screw Terminal and USB-622x/625x/628x Mass Termination Devices) Use the supplied strain relief hardware to provide strain relief for your USB cable. Adhere the cable tie mount to the rear panel of the USB-62xx Screw Terminal or USB-62xx Mass Termination device, as shown in Figure 1-6. Thread a zip tie through the cable tie mount and tighten around the USB cable.

Figure 1-6. USB Cable Strain Relief on USB-62xx Screw Terminal and USB-62xx Mass Termination Devices

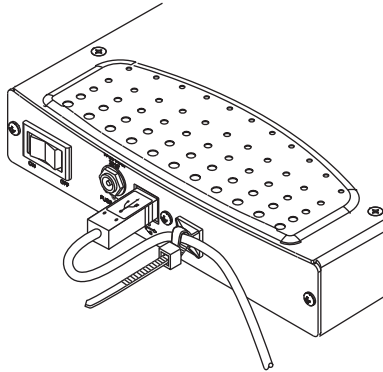

(USB-622x/625x BNC Devices) Thread a zip tie through two of the strain relief holes on the end cap to provide strain relief for your USB cable as shown in Figure 1-7. The strain relief holes can also be used as cable management for signal wires to/from the screw terminals and BNC connectors.

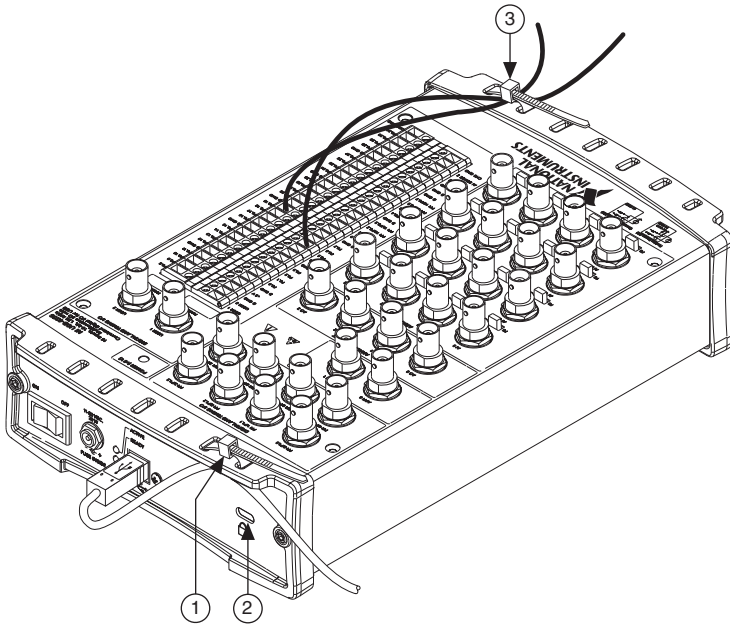
Figure 1-7. USB Cable Strain Relief on USB-62xx BNC Devices

1 USB Cable Strain Relief
2 Security Cable Slot

3 Signal Wire Strain Relief

USB Device Fuse Replacement

M Series USB devices have a replaceable T 2A 250V (5 × 20 mm) fuse that protects the device from overcurrent through the power connector.

(USB-6281/6289 Devices) USB-628x devices also have a replaceable Littelfuse 0453002 (F 2A 250V) fuse that protects the device from overcurrent through the +5 V terminal(s).

(USB-622x/625x/628x Screw Terminal Devices) To replace a broken fuse in the USB-62xx Screw Terminal, complete the following steps.

1. Power down and unplug the device.
2. Remove the USB cable and all signal wires from the device.
3. Loosen the four Phillips screws that attach the back lid to the enclosure and remove the lid.
4. Replace the broken fuse while referring to Figure 1-8 for the fuse locations.

Figure 1-8. USB-62xx Screw Terminal Fuse Locations

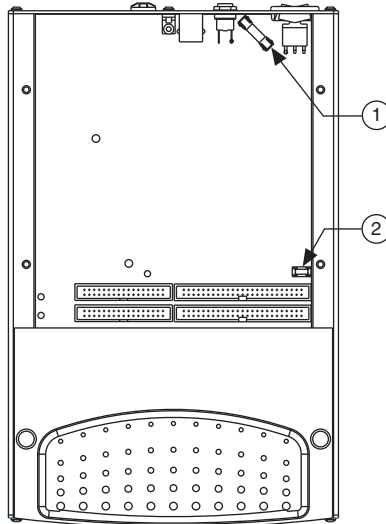

1 T 2A 250V (5 × 20 mm) Fuse

2 Littelfuse 0453002 Fuse on USB-628x Devices

5. Replace the lid and screws.

(USB-622x/625x BNC Devices) To replace a broken fuse in the USB-62xx BNC, complete the following steps.

1. Power down and unplug the device.



Note Take proper ESD precautions when handling the device.

2. Remove the USB cable and all BNC cables and signal wires from the device.

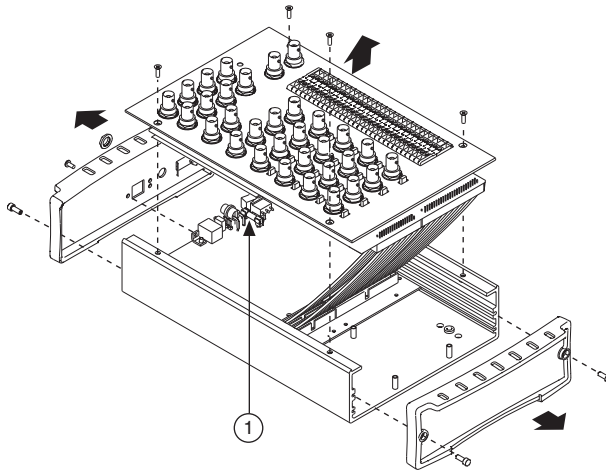
Figure 1-9. USB-62xx BNC Fuse Location

1 T 2A 250V (5 × 20 mm) Fuse

3. Remove both end pieces by unscrewing the four sockethead cap screws with a 7/64 in. hex wrench.



Note The end pieces are attached using self-threading screws. Repeated screwing and unscrewing of self-threading screws will produce a compromised connection.

4. With a Phillips #2 screwdriver, remove the Phillips 4-40 screw adjacent to the USB connector.
5. Remove the nut from the power connector.
6. Remove the four Phillips 4-40 screws that attach the top panel to the enclosure and remove the panel and connector unit.
7. Replace the broken fuse while referring to Figure 1-9 for the fuse location.
8. Replace the top panel, screws, nut, and end pieces.

(USB-622x/625x/628x Mass Termination Devices) To replace a broken fuse in the USB-62xx Mass Termination, complete the following steps.

1. Power down and unplug the device.
2. Remove the USB cable and signal cable(s) from the device.
3. Loosen the four Phillips screws that attach the lid to the enclosure and remove the lid.
4. Replace the broken fuse while referring to Figure 1-10 for the fuse locations.

Figure 1-10. USB-62xx Mass Termination Fuse Locations

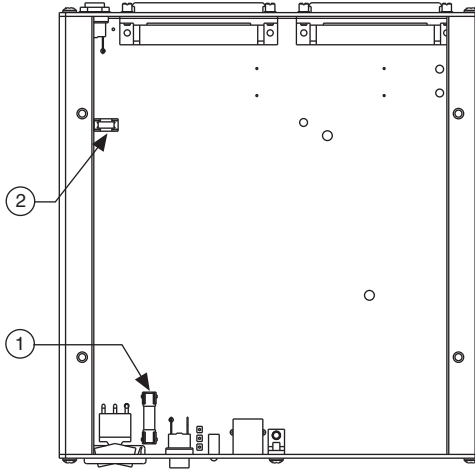

- 1 T 2A 250V (5 × 20 mm) Fuse
- 2 Littelfuse 0453002 Fuse on USB-628x Devices

5. Replace the lid and screws.

USB Device Security Cable Slot

(USB-622x/625x BNC Devices) The security cable slot, shown in Figure 1-7, allows you to attach an optional antitheft device to your USB device.



Note The security cable is designed to act as a deterrent, but may not prevent the device from being mishandled or stolen. For more information, refer to the documentation that accompanied the security cable.



Note The security cable slot on the USB-62xx BNC may not be compatible with all antitheft cables.

Installing a Ferrite

(USB-62221/6229 BNC Devices) To ensure EMC compliance, you must install the ferrite shipped with the USB-6221/6229 BNC.

Loop the power cabling through the ferrite at least five times. Install the ferrite as close as possible to the end of the power cable, as shown in Figure 1-11.

Figure 1-11. Installing the Ferrite on the Power Cable

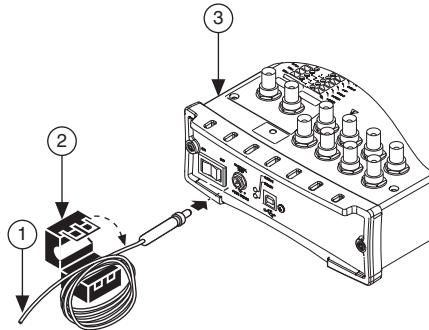

1 Power Cable
2 Ferrite

3 NI USB-6221/6229 BNC Device

Pinouts

Refer to Appendix A, *Module/Device-Specific Information*, for M Series device pinouts.

Specifications

Refer to the device specifications document for your device. M Series device documentation is available on ni.com/manuals.

Accessories and Cables

NI offers a variety of accessories and cables to use with your multifunction I/O DAQ module device. Refer to the *Cables and Accessories* section of Chapter 2, *DAQ System Overview*, for more information.

DAQ System Overview

Figure 2-1 shows a typical DAQ system, which includes sensors, transducers, signal conditioning devices, cables that connect the various devices to the accessories, the M Series device, programming software, and PC. The following sections cover the components of a typical DAQ system.

Figure 2-1. Components of a Typical DAQ System

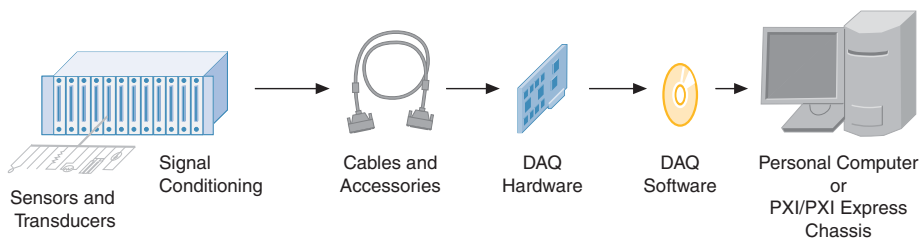

DAQ Hardware

DAQ hardware digitizes signals, performs D/A conversions to generate analog output signals, and measures and controls digital I/O signals. Figure 2-2 features components common to all M Series devices.

Figure 2-2. General M Series Block Diagram

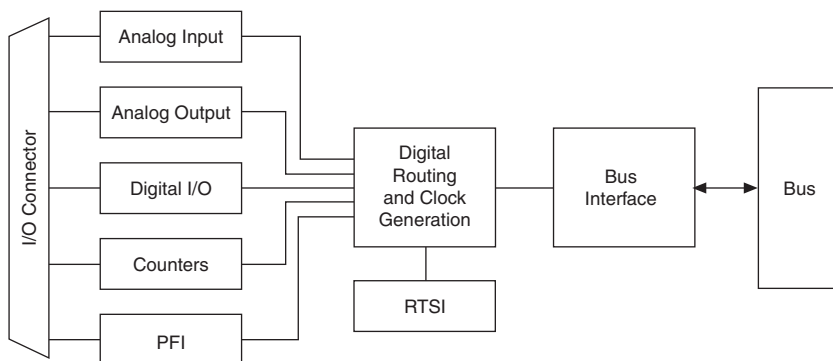

DAQ-STC2 and DAQ-6202

The DAQ-STC2 and DAQ-6202 implement a high-performance digital engine for M Series data acquisition hardware. Some key features of this engine include the following:

- Flexible AI and AO sample and convert timing
- Many triggering modes
- Independent AI, AO, DI, and DO FIFOs
- Generation and routing of RTSI signals for multi-device synchronization
- Generation and routing of internal and external timing signals
- Two flexible 32-bit counter/timer modules with hardware gating
- Digital waveform acquisition and generation
- Static DIO signals
- True 5 V high current drive DO
- DI change detection
- PLL for clock synchronization
- Seamless interface to signal conditioning accessories
- PCI/PXI interface
- Independent scatter-gather DMA controllers for all acquisition and generation functions

Calibration Circuitry

The M Series analog inputs and outputs have calibration circuitry to correct gain and offset errors. You can calibrate the device to minimize AI and AO errors caused by time and temperature drift at run time. No external circuitry is necessary; an internal reference ensures high accuracy and stability over time and temperature changes.

Factory-calibration constants are permanently stored in an onboard EEPROM and cannot be modified. When you self-calibrate the device, as described in the *Device Self-Calibration* section of Chapter 1, *Getting Started*, software stores new constants in a user-modifiable section of the EEPROM. To return a device to its initial factory calibration settings, software can copy the factory-calibration constants to the user-modifiable section of the EEPROM. Refer to the *NI-DAQmx Help* or the *LabVIEW Help* for more information about using calibration constants.

For a detailed calibration procedure for M Series devices, refer to the *B/E/M/S/X Series Calibration Procedure* available at ni.com/manuals.

Cables and Accessories

NI offers a variety of products to use with M Series PCI, PCI Express, PXI, PXI Express, USB devices, including cables, connector blocks, and other accessories, as follows:

- Shielded cables and cable assemblies, and unshielded ribbon cables and cable assemblies
- Screw terminal connector blocks, shielded and unshielded
- RTSI bus cables
- SCXI modules and accessories for isolating, amplifying, exciting, and multiplexing signals; with SCXI you can condition and acquire up to 3,072 channels
- Low-channel-count signal conditioning modules, devices, and accessories, including conditioning for strain gauges and RTDs, simultaneous sample and hold circuitry, and relays

Refer to the appropriate section for your device connector type—[68-Pin M Series Cables and Accessories](#) or [37-Pin M Series Cables and Accessories](#). For more specific information about these products, refer to ni.com.



Note For compliance with Electromagnetic Compatibility (EMC) requirements, this product must be operated with shielded cables and accessories. If unshielded cables or accessories are used, the EMC specifications are no longer guaranteed unless all unshielded cables and/or accessories are installed in a shielded enclosure with properly designed and shielded input/output ports.

Refer to the [68-Pin Custom Cabling and Connectivity](#) or [37-Pin Custom Cabling](#) section of this chapter and the [Field Wiring Considerations](#) section of Chapter 4, [Analog Input](#), for information about how to select accessories for your M Series device.

68-Pin M Series Cables and Accessories

This section describes some cable and accessory options for M Series devices with one or two 68-pin connectors. Refer to the following sections for descriptions of these cables and accessories. Refer to ni.com for other accessory options.

Table 2-1. 68-Pin M Series Device/Module Cables and Accessories

Cables and Accessories Type		PCI, PCI Express, PXI, PXI Express Devices and Modules		USB Mass Termination Devices		
		622x/625x/628x Connector 0 6224/6229/6254/6259/6284/6289 Connector 1	6225/6255 Connector 1	622x/625x/628x Connector 0 6229/6259/6289 Connector 1	6225/6255 Connector 1	
Cables	Shielded	SHC68-68-EPM	SHC68-68	SC68-68-EPM	SHC68-68	
	Unshielded	RC68-68	RC68-68	RC68-68	RC68-68	
Accessories	Shielded	Screw Terminal Block	SCB-68A SCB-68 TB-2706*	SCB-68A SCB-68	SCB-68A SCB-68	
		BNC Terminal Block	BNC-2110 BNC-2111 BNC-2120 BNC-2090A BNC-2090	BNC-2115	BNC-2110 BNC-2111 BNC-2120 BNC-2090A BNC-2090	BNC-2115
		SCC	SC-2345 SC-2350 SCC-68	N/A	SC-2345 SC-2350 SCC-68	N/A
	Unshielded	Screw Terminal Block	CB-68LP CB-68LPR TBX-68	CB-68LP CB-68LPR TBX-68	CB-68LP CB-68LPR TBX-68	CB-68LP CB-68LPR TBX-68
		Custom Connectivity	CA-1000	CA-1000	CA-1000	CA-1000
* Can only be attached directly to PXI modules front connector only, and does not require a cable.						

68-Pin Cables

Cabling options differ between the 68-pin PCI/PCI Express/PXI/PXI Express devices and modules and USB Mass Termination devices.

PCI/PCI Express/PXI/PXI Express Device/Module 68-Pin Cables

You can use the following cables with PCI, PCI Express, PXI, and PXI Express M Series devices and modules:

- **SHC68-68-EPM**¹—(Recommended) High-performance shielded cable designed for M/X Series devices. It has individual bundles separating analog and digital signals. Each differential analog input channel is routed on an individually shielded twisted pair of wires. Analog outputs are also individually shielded.
- **SHC68-68**—(Recommended) Lower-cost shielded cable with 34 twisted pairs of wire. The cable is recommended for PCI/PXI-6225/6255 Connector 1.



Note You *must* use the SHC68-68 cable on Connector 1 of PCI/PXI-6225/6255 devices and modules. The SHC68-68-EPM cable can be used on Connector 0 of all M Series PCI, PCI Express, PXI, and PXI Express devices and modules, and on Connector 1 of NI PCI/PCIe/PXI/PXI-6224/6229/6254/6259/6284/6289 devices and modules.

- **RC68-68**—Highly-flexible unshielded ribbon cable.

USB Mass Termination Device 68-Pin Cables

You can use the following cables with USB devices with mass termination connectors:

- **SH68-68-EPM**²—(Recommended) High-performance cable with individual bundles separating analog and digital signals. Each differential analog input channel is routed on an individually shielded twisted pair of wires. Analog outputs are also individually shielded.
- **SH68-68-S**—(Recommended) Shielded cable with 34 twisted pairs of wire. Each differential analog input channel on Connector 1 is routed on a twisted pair on the SH68-68-S cable. The cable is recommended for USB-6225/6255 Mass Termination Connector 1.



Note You *must* use the SH68-68-S cable on Connector 1 of USB-6225/6255 Mass Termination devices. The SH68-68-EPM cable can be used on Connector 0 of all M Series USB Mass Termination devices, and on Connector 1 of USB-6229/6259/6289 devices and modules.

- **R68-68**—Highly-flexible unshielded ribbon cable.

¹ NI recommends that you use the SHC68-68-EPM cable; however, an SHC68-68-EP cable works with PCI/PCI Express/PXI/PXI Express devices and modules.

² NI recommends that you use the SH68-68-EPM cable; however, an SH68-68-EP cable will work with USB Mass Termination devices.

68-Pin BNC Accessories

You can use your 68-pin cable to connect your DAQ device to the following BNC accessories:

- **BNC-2110**—Provides BNC connectivity to all analog signals, some digital signals, and spring terminals for other digital signals
- **BNC-2111**—Provides BNC connectivity to 16 single-ended analog input signals, two analog output signals, five DIO/PFI signals, and the external reference voltage for analog output
- **BNC-2120**—Similar to the BNC-2110, and also has a built-in function generator, quadrature encoder, temperature reference, and thermocouple connector
- **BNC-2090A, BNC-2090**—Desktop/rack-mountable device with 22 BNCs for connecting analog, digital, and timing signals
- **BNC-2115**—(**NI 6225/6255 Devices**) Provides BNC connectivity to 24 of the differential (48 single ended) analog input signals on Connector 1 of NI 6225/6255 devices

68-Pin Screw Terminal Accessories

You can use your 68-pin cable to connect your DAQ device to the following screw terminal accessories:

- **SCB-68A, SCB-68**—Shielded connector block with temperature sensor
- **TB-2706**¹—Front panel mounted terminal block for PXI/PXI Express M Series devices
- **SCC-68**—I/O connector block with screw terminals, general breadboard area, bus terminals, and four expansion slots for SCC signal conditioning modules.
- **TBX-68**—DIN rail-mountable connector block
- **CB-68LP, CB-68LPR**—Unshielded connector blocks

RTSI Cables

Use RTSI bus cables to connect timing and synchronization signals among PCI/PCI Express devices, such as X Series, E Series, CAN, and other measurement, vision, and motion devices. Since PXI devices use PXI backplane signals for timing and synchronization, no cables are required.

SCC Carriers and Accessories

SCC provides portable, modular signal conditioning to your DAQ system. Use your 68-pin cable to connect your device/module to an SCC module carrier, such as the following:

- **SCC-68**—68-pin terminal block with SCC expansion slots
- **SC-2345**—Shielded carrier for up to 20 SCC modules
- **SC-2350**—Shielded SCC carrier for TEDS sensors

¹ TB-2706 uses Connector 0 of your PXI/PXI Express module, therefore does not require a cable. After a TB-2706 is installed, Connector 1 cannot be used.

You can use either connector on M Series devices to control an SCC module carrier.



Note (NI 6225/6255 Devices) SCC is supported only on Connector 0.



Note PCI Express users should consider the power limits on certain SCC modules without an external power supply. Refer to the device specifications, and the [When to Use the Disk Drive Power Connector](#) section of Chapter 1, [Getting Started](#), for information about power limits and increasing the current the device can supply on the +5 V terminal.

SCXI

SCXI is a programmable signal conditioning system designed for measurement and automation applications. To connect your M Series device or module to an SCXI chassis, use the SCXI-1349 adapter and your 68-pin cable.

Use Connector 0 of your M Series device to control SCXI in parallel and multiplexed mode. Use Connector 1 of your M Series device to control SCXI in parallel mode.



Note (NI 6225/6255 Devices) SCXI is supported only on Connector 0.



Note When using Connector 1 in parallel mode with SCXI modules that support track and hold, you must programmatically disable track and hold.

You also can use an M Series PXI module to control the SCXI section of a PXI/SCXI combination chassis, such as the PXI-1010 or PXI-1011. The M Series device in the rightmost PXI slot controls the SCXI devices. No cables or adapters are necessary.

Refer to the documentation for your SCXI chassis and modules for detailed information about using SCXI with a DAQ device.

68-Pin Custom Cabling and Connectivity

The CA-1000 is a configurable enclosure that gives user-defined connectivity and flexibility through customized panellets. Visit ni.com for more information about the CA-1000.

NI offers cables and accessories for many applications. However, if you want to develop your own cable, adhere to the following guidelines for best results:

- For AI signals, use shielded, twisted-pair wires for each AI pair of differential inputs. Connect the shield for each signal pair to the ground reference at the source.
- Route the analog lines separately from the digital lines.
- When using a cable shield, use separate shields for the analog and digital sections of the cable. To prevent noise when using a cable shield, use separate shields for the analog and digital sections of the cable.

For more information on the connectors used for DAQ devices, refer to the *NI DAQ Device Custom Cables, Replacement Connectors, and Screws* document by going to ni.com/info and entering the Info Code `rdspmb`.

USB Device Accessories, USB Cable, and Power Supply

USB Screw Terminal and USB Mass Termination devices feature connectivity directly on the device and do not require an accessory for interfacing to signals. However, NI offers a variety of products to use with the USB M Series devices, as shown in Table 2-2.

Table 2-2. USB Device Cabling, Accessories, and Power Supply

Description	Part Number
NI USB DAQ Power Supply	780046-01
Externally Powered USB M Series Panel Mounting Kit*	780214-01
USB cable with locking screw, 2 m	780534-01
BNC Male (Plug) to BNC Male (Plug) Cable	779697-02
* Not for use with NI USB BNC devices.	

37-Pin M Series Cables and Accessories

This section describes some cable and accessory options for the PCI-6221 (37-pin) device. Refer to the following sections for descriptions of these cables and accessories. Refer to ni.com for other accessory options.

Table 2-3. PCI-6221 (37-Pin) Cables and Accessories

Cables and Accessories Type		Supported Models for PCI-6221 (37-Pin) Device
Cables	Shielded	SH37F-37M SH37F-P-4
	Unshielded	R37F-37M
Accessories	Unshielded Screw Terminal Block	CB-37F-HVD CB-37FV CB-37FH CB-37F-LP
	Custom Connectivity	TB-37F-37SC TB-37F-37CP

37-Pin Cables

In most applications, you can use the following cables:

- **SH37F-37M**—(Recommended) 37-pin female-to-male shielded I/O cable, (1 m and 2 m lengths)
- **SH37F-P-4**—37-pin female-to-pigtails shielded I/O cable
- **R37F-37M**—37-pin female-to-male ribbon I/O cable

37-Pin Screw Terminal Accessories

National Instruments offers several styles of screw terminal connector blocks. Use your 37-pin cable to connect a PCI-6221 (37-pin) device to one of the following connector blocks:

- **CB-37F-HVD**—37-pin DIN rail screw terminal block
- **CB-37FV**—Vertical DIN rail-mountable terminal block with 37 screw terminals
- **CB-37FH**—Horizontal DIN rail-mountable connector block with 37 screw terminals
- **CB-37F-LP**—Low profile connector block with 37 screw terminals

RTSI Cables

Use RTSI bus cables to connect timing and synchronization signals among PCI/PCI Express devices, such as X Series, E Series, CAN, and other measurement, vision, and motion devices. Since PXI devices use PXI backplane signals for timing and synchronization, no cables are required.

37-Pin Custom Cabling

NI offers cables and accessories for many applications. However, if you want to develop your own cable, the following kits can assist you:

- **TB-37F-37SC**—37-pin solder cup terminals, shell with strain relief
- **TB-37F-37CP**—37-pin crimp & poke terminals, shell with strain relief

Adhere to the following guidelines for best results:

- For AI signals, use shielded, twisted-pair wires for each AI pair of differential inputs. Connect the shield for each signal pair to the ground reference at the source.
- Route the analog lines separately from the digital lines.
- When using a cable shield, use separate shields for the analog and digital sections of the cable. Failure to do so results in noise coupling into the analog signals from transient digital signals.

For more information on the connectors used for DAQ devices, refer to the *NI DAQ Device Custom Cables, Replacement Connectors, and Screws* document by going to ni.com/info and entering the Info Code `rdspmb`.

Signal Conditioning

Many sensors and transducers require signal conditioning before a measurement system can effectively and accurately acquire the signal. The front-end signal conditioning system can include functions such as signal amplification, attenuation, filtering, electrical isolation, simultaneous sampling, and multiplexing. In addition, many transducers require excitation currents or voltages, bridge completion, linearization, or high amplification for proper and accurate operation. Therefore, most computer-based measurement systems include some form of signal conditioning in addition to plug-in data acquisition DAQ devices.

Sensors and Transducers

Sensors can generate electrical signals to measure physical phenomena, such as temperature, force, sound, or light. Some commonly used sensors are strain gauges, thermocouples, thermistors, angular encoders, linear encoders, and resistance temperature detectors (RTDs).

To measure signals from these various transducers, you must convert them into a form that a DAQ device can accept. For example, the output voltage of most thermocouples is very small and susceptible to noise. Therefore, you may need to amplify or filter the thermocouple output before digitizing it. The manipulation of signals to prepare them for digitizing is called signal conditioning.

For more information about sensors, refer to the following documents:

- For general information about sensors, visit ni.com/sensors.
- If you are using LabVIEW, refer to the *LabVIEW Help* by selecting **Help»Search the LabVIEW Help** in LabVIEW and then navigate to the **Taking Measurements** book on the **Contents** tab.
- If you are using other application software, refer to *Common Sensors* in the *NI-DAQmx Help* or the *LabVIEW Help*.

Signal Conditioning Options

For more information about SCXI and SCC products, refer to ni.com/signalconditioning.

SCXI

SCXI is a front-end signal conditioning and switching system for various measurement devices, including M Series devices. An SCXI system consists of a rugged chassis that houses shielded signal conditioning modules that amplify, filter, isolate, and multiplex analog signals from thermocouples or other transducers. SCXI is designed for large measurement systems or systems requiring high-speed acquisition.

System features include the following:

- **Modular architecture**—Choose your measurement technology
- **Expandability**—Expand your system to 3,072 channels

- **Integration**—Combine analog input, analog output, digital I/O, and switching into a single, unified platform
- **High bandwidth**—Acquire signals at high rates
- **Connectivity**—Select from SCXI modules with thermocouple connectors or terminal blocks



Note SCXI is *not* supported on the PCI-6221 (37-pin), USB-622x/625x/628x Screw Terminal, or USB-622x/625x BNC devices.

SCC

SCC is a front-end signal conditioning system for M Series plug-in data acquisition devices. An SCC system consists of a shielded carrier that holds up to 20 single- or dual-channel SCC modules for conditioning thermocouples and other transducers. SCC is designed for small measurement systems where you need only a few channels of each signal type, or for portable applications. SCC systems also offer the most comprehensive and flexible signal connectivity options.

System features include the following:

- **Modular architecture**—Select your measurement technology on a per-channel basis
- **Small-channel systems**—Condition up to 16 analog input and eight digital I/O lines
- **Low-profile/portable**—Integrates well with other laptop computer measurement technologies
- **High bandwidth**—Acquire signals at rates up to 1.25 MHz
- **Connectivity**—Incorporates panelette technology to offer custom connectivity to thermocouple, BNC, LEMO™ (B Series), and MIL-Spec connectors



Note PCI Express users should consider the power limits on certain SCC modules without an external power supply. Refer to the device specifications, and the [When to Use the Disk Drive Power Connector](#) section of Chapter 1, [Getting Started](#), for information about power limits and increasing the current the device can supply on the +5 V terminal.



Note SCC is *not* supported on the PCI-6221 (37-pin), USB-622x/625x/628x Screw Terminal, or USB-622x/625x BNC devices.

Programming Devices in Software

National Instruments measurement devices are packaged with NI-DAQmx driver software, an extensive library of functions and VIs you can call from your application software, such as LabVIEW or LabWindows™/CVI™, to program all the features of your NI measurement devices. Driver software has an application programming interface (API), which is a library of VIs, functions, classes, attributes, and properties for creating applications for your device.

M Series devices use the NI-DAQmx driver. NI-DAQmx includes a collection of programming examples to help you get started developing an application. You can modify example code and save it in an application. You can use examples to develop a new application or add example code to an existing application.

To locate LabVIEW, LabWindows/CVI, Measurement Studio, Visual Basic, and ANSI C examples, refer to the KnowledgeBase document, *Where Can I Find NI-DAQmx Examples?*, by going to ni.com/info and entering the Info Code `daqmxexp`.

For additional examples, refer to ni.com/examples.

Table 2-4 lists the earliest NI-DAQmx support version for each M Series device.

Table 2-4. M Series NI-DAQmx Software Support

Device	NI-DAQmx Earliest Version Support
NI PCI/PXI-6220/6221/6224/6229	NI-DAQmx 7.4
NI PCI-6221 (37-pin)	NI-DAQmx 7.5
NI USB-6221/6229 Screw Terminal	NI-DAQmx 8.3
NI USB-6221/6229 BNC	NI-DAQmx 8.6.1
NI PCI/PXI-6225	NI-DAQmx 7.4
NI USB-6225 Screw Terminal/Mass Termination	NI-DAQmx 8.6.1
NI PCI/PXI-6250/6251/6254/6259	NI-DAQmx 7.4
NI PCIe-6251/6259	NI-DAQmx 8.0.1
NI PXIe-6251/6259	NI-DAQmx 8.3
NI USB-6251/6259 Screw Terminal/Mass Termination	NI-DAQmx 8.1
NI USB-6251/6259 BNC	NI-DAQmx 8.6.1
NI PCI/PXI-6255	NI-DAQmx 8.1
NI USB-6255 Screw Terminal/Mass Termination	NI-DAQmx 8.6.1
NI PCI/PXI-6280/6281/6284/6289	NI-DAQmx 7.4
NI USB-6281/6289 Screw Terminal/Mass Termination	NI-DAQmx 8.7.1



Note NI recommends using the latest version of NI-DAQmx supported for your OS. Refer to the NI-DAQmx download page by going to ni.com/info and entering the Info Code `nidaqmxdownloads`.

Connector and LED Information

The *I/O Connector Signal Descriptions*, *+5 V Power Source*, and *USER 1 and USER 2* sections contain information about M Series connector signals, power, and user-defined terminals. The *LED Patterns* section contains information about M Series USB device LEDs.



Note Refer to Appendix A, *Module/Device-Specific Information*, for device I/O connector pinouts.

I/O Connector Signal Descriptions

Table 3-1 describes the signals found on the I/O connectors. Not all signals are available on all devices.

Table 3-1. I/O Connector Signals

Signal Name	Reference	Direction	Description
AI GND	—	—	Analog Input Ground —These terminals are the reference point for single-ended AI measurements in RSE mode and the bias current return point for DIFF measurements. All three ground references—AI GND, AO GND, and D GND—are connected on the device. Refer to the <i>Connecting Analog Input Signals</i> section of Chapter 4, <i>Analog Input</i> .
AI <0..79>	Varies	Input	Analog Input Channels —For single-ended measurements, each signal is an analog input voltage channel. In RSE mode, AI GND is the reference for these signals. In NRSE mode, the reference for each AI <0..15> signal is AI SENSE; the reference for each AI <16..63> and AI <64..79> signal is AI SENSE 2*. For differential measurements, AI 0 and AI 8 are the positive and negative inputs of differential analog input channel 0. Similarly, the following signal pairs also form differential input channels: <AI 1, AI 9>, <AI 2, AI 10>, <AI 3, AI 11>, and so on. Refer to the <i>Connecting Analog Input Signals</i> section of Chapter 4, <i>Analog Input</i> .
AI SENSE, AI SENSE 2	—	Input	Analog Input Sense —In NRSE mode, the reference for each AI <0..15> signal is AI SENSE; the reference for each AI <16..63> and AI <64..79> signal is AI SENSE 2*. Refer to the <i>Connecting Analog Input Signals</i> section of Chapter 4, <i>Analog Input</i> .
AO <0..3>	AO GND	Output	Analog Output Channels —These terminals supply the voltage output. Refer to the <i>Connecting Analog Output Signals</i> section of Chapter 5, <i>Analog Output</i> .
AO GND	—	—	Analog Output Ground —AO GND is the reference for AO <0..3>. All three ground references—AI GND, AO GND, and D GND—are connected on the device. Refer to the <i>Connecting Analog Output Signals</i> section of Chapter 5, <i>Analog Output</i> .

Table 3-1. I/O Connector Signals (Continued)

Signal Name	Reference	Direction	Description
D GND	—	—	Digital Ground —D GND supplies the reference for P0.<0..31>, PFI <0..15>/P1/P2, and +5 V. All three ground references—AI GND, AO GND, and D GND—are connected on the device. Refer to the <i>Connecting Digital I/O Signals</i> section of Chapter 6, <i>Digital I/O</i> .
P0.<0..31>	D GND	Input or Output	Port 0 Digital I/O Channels —You can individually configure each signal as an input or output. Refer to the <i>Connecting Digital I/O Signals</i> section of Chapter 6, <i>Digital I/O</i> .
APFI <0,1>	AO GND or AI GND	Input	Analog Programmable Function Interface Channels —Each APFI signal can be used as AO external reference inputs for AO <0..3>, AO external offset input, or as an analog trigger input. APFI <0,1> are referenced to AI GND when they are used as analog trigger inputs. APFI <0,1> are referenced to AO GND when they are used as AO external offset or reference inputs. These functions are not available on all devices; refer to the specifications for your device. Refer to the <i>APFI <0,1> Terminals</i> section of Chapter 11, <i>Triggering</i> .
+5 V	D GND	Output	+5 V Power Source —These terminals provide a fused +5 V power source. Refer to the <i>+5 V Power Source</i> section for more information.
PFI <0..7>/ P1.<0..7>	D GND	Input or Output	Programmable Function Interface or Port 1 Digital I/O Channels —Each of these terminals can be individually configured as a PFI terminal or a digital I/O terminal. As an input, each PFI terminal can be used to supply an external source for AI, AO, DI, and DO timing signals or counter/timer inputs. As a PFI output, you can route many different internal AI, AO, DI, or DO timing signals to each PFI terminal. You also can route the counter/timer outputs to each PFI terminal. As a Port 1 digital I/O signal, you can individually configure each signal as an input or output. Refer to the <i>Connecting Digital I/O Signals</i> section of Chapter 6, <i>Digital I/O</i> , or to Chapter 8, <i>PFI</i> .

Table 3-1. I/O Connector Signals (Continued)

Signal Name	Reference	Direction	Description
PFI <8..15>/ P2.<0..7>	D GND	Input or Output	<p>Programmable Function Interface or Port 2 Digital I/O Channels—Each of these terminals can be individually configured as a PFI terminal or a digital I/O terminal.</p> <p>As an input, each PFI terminal can be used to supply an external source for AI, AO, DI, and DO timing signals or counter/timer inputs.</p> <p>As a PFI output, you can route many different internal AI, AO, DI, or DO timing signals to each PFI terminal. You also can route the counter/timer outputs to each PFI terminal.</p> <p>As a Port 2 digital I/O signal, you can individually configure each signal as an input or output.</p> <p>Refer to the Connecting Digital I/O Signals section of Chapter 6, Digital I/O, or to Chapter 8, PFI. Refer to Table 7-6, 68-Pin Device Default NI-DAQmx Counter/Timer Pins, to find the default NI-DAQmx counter/timer pins for most M Series devices.</p>
USER <1,2>	—	—	<p>User-Defined Channels—On USB-62xx BNC devices, the USER <1,2> BNC connectors allow you to use a BNC connector for a digital or timing I/O signal of your choice. The USER <1,2> BNC connectors are internally routed to the USER <1,2> screw terminals. Refer to the USER 1 and USER 2 section for more information.</p>
CHS GND	—	—	<p>Chassis Ground[†]—This terminal connects to the USB-62xx BNC device metal enclosure. You can connect your cable’s shield wire to CHS GND for a ground connection. Refer to the USB Device Chassis Ground section of Chapter 1, Getting Started.</p>
NC	—	—	<p>No connect—Do <i>not</i> connect signals to these terminals.</p>
<p>* On NI 6225 devices, the reference for each AI <16..63> signal is AI SENSE 2, and each AI <64..79> signal is AI SENSE in NRSE mode.</p> <p>[†] USB-62xx Screw Terminal users can connect the shield of a shielded cable to the chassis ground lug for a ground connection. The chassis ground lug is not available on all device versions.</p>			

+5 V Power Source

The +5 V terminals on the I/O connector supply +5 V referenced to D GND. Use these terminals to power external circuitry.

Newer revision M Series devices have a traditional fuse to protect the supply from overcurrent conditions. This fuse is not customer-replaceable; if the fuse permanently opens, return the device to NI for repair.

Older revision M Series devices have a self-resetting fuse to protect the supply from overcurrent conditions. This fuse resets automatically within a few seconds after the overcurrent condition is removed. For more information about the self-resetting fuse and precautions to take to avoid improper connection of +5 V and ground terminals, refer to the KnowledgeBase document, *Self-Resetting Fuse Additional Information*, by going to ni.com/info and entering the Info Code `pptc`.

(USB-6281/6289 Devices) All USB-628x devices have a user-replaceable socketed fuse to protect the supply from overcurrent conditions. When an overcurrent condition occurs, check your cabling to the +5 V terminals and replace the fuse as described in the *USB Device Fuse Replacement* section of Chapter 1, *Getting Started*.



Caution *Never* connect the +5 V power terminals to analog or digital ground or to any other voltage source on the M Series device or any other device. Doing so can damage the device and the computer. NI is *not* liable for damage resulting from such a connection.

The power rating on most devices is +4.75 to +5.25 VDC at 1 A.

Refer to the specifications document for your device to obtain the device power rating.



Note (NI PCIe-6251/6259 Devices) M Series PCI Express devices supply less than 1 A of +5 V power unless you use the disk drive power connector. Refer to the *Getting Started with M Series PCI Express Devices and the Disk Drive Power Connector* section of Chapter 1, *Getting Started*, for more information.



Note The NI 6221 (37-pin) device does not have a +5 V terminal.

USER 1 and USER 2

(NI USB-622x/625x BNC Devices) The USER connectors allow you to use a BNC connector for a digital or timing I/O signal of your choice. The USER 1 and USER 2 BNC connectors are routed (internal to the USB BNC device) to the USER 1 and USER 2 screw terminals, as shown in Figure 3-1.

Figure 3-1. USER 1 and USER 2 BNC Connections

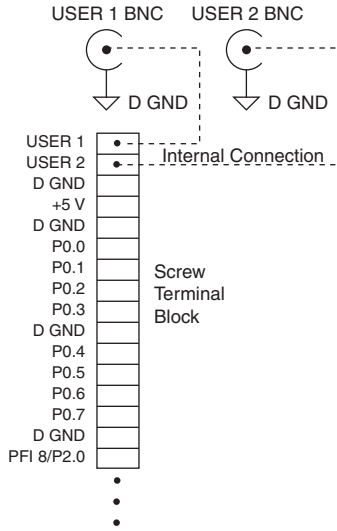
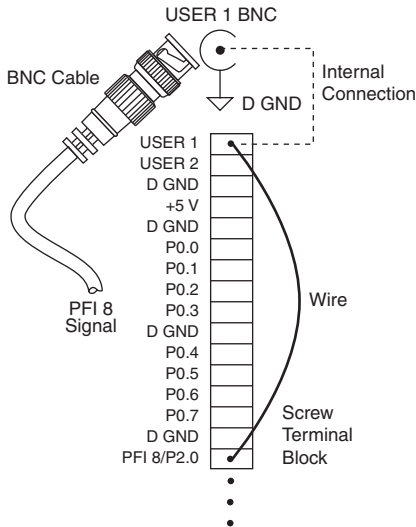

Figure 3-2 shows an example of how to use the USER 1 and USER 2 BNCs. To access the PFI 8 signal from a BNC, connect USER 1 on the screw terminal block to PFI 8 with a wire.

Figure 3-2. Connecting PFI 8 to USER 1 BNC



The designated space below each USER BNC is for marking or labeling signal names.

RTSI Connector Pinout

(PCI/PCIe-622x/625x/628x Devices) Refer to the *RTSI Connector Pinout* section of Chapter 9, *Digital Routing and Clock Generation*, for information about the RTSI connector.

LED Patterns

(USB-622x/625x/628x Devices) All variants of M Series USB devices have LEDs labeled ACTIVE and READY. The ACTIVE LED indicates activity over the bus. The READY LED indicates whether or not the device is configured. Table 3-2 shows the behavior of the LEDs.



Note USB-62xx BNC devices also have a POWER (+5 V) LED on the top panel. The POWER (+5 V) LED indicates device power.

Table 3-2. LED Patterns

POWER (+5 V) LED*	ACTIVE LED	READY LED	USB Device State
Off	Off	Off	The device is not powered.
On	Off	Off	(USB-62xx Screw Terminal/Mass Termination Devices) The device is not powered. (USB-62xx BNC Devices) The device is powered but not connected to the host computer.
On	Off	On	The device is configured, but there is no activity over the bus.
On	On	On	The device is configured and there is activity over the bus.
On	Blinking	On	

* USB-625x/628x BNC devices only.

Analog Input

Figure 4-1 shows the analog input circuitry of M Series devices.

Figure 4-1. M Series Analog Input Circuitry

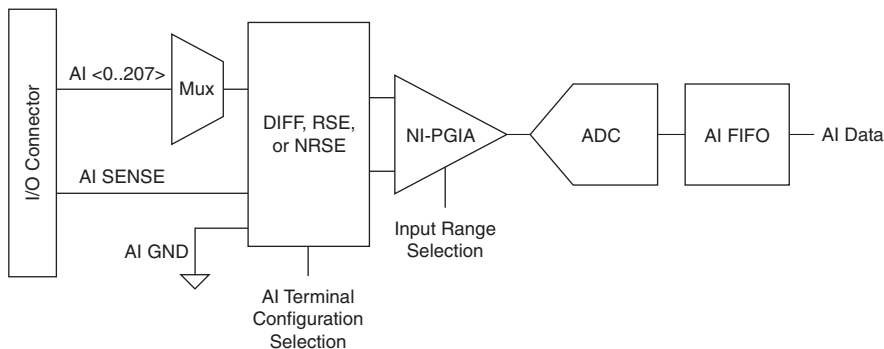

The main blocks featured in the M Series analog input circuitry are as follows:

- **I/O Connector**—You can connect analog input signals to the M Series device through the I/O connector. The proper way to connect analog input signals depends on the analog input ground-reference settings, described in the [Analog Input Ground-Reference Settings](#) section. Also refer to Appendix A, [Module/Device-Specific Information](#), for device I/O connector pinouts.
- **Mux**—Each M Series device has one analog-to-digital converter (ADC). The multiplexers (mux) route one AI channel at a time to the ADC through the NI-PGIA.
- **Ground-Reference Settings**—The analog input ground-reference settings circuitry selects between differential, referenced single-ended, and non-referenced single-ended input modes. Each AI channel can use a different mode.
- **Instrumentation Amplifier (NI-PGIA)**—The NI programmable gain instrumentation amplifier (NI-PGIA) is a measurement and instrument class amplifier that minimizes settling times for all input ranges. The NI-PGIA can amplify or attenuate an AI signal to ensure that you use the maximum resolution of the ADC.

M Series devices use the NI-PGIA to deliver high accuracy even when sampling multiple channels with small input ranges at fast rates. M Series devices can sample channels in any order at the maximum conversion rate, and you can individually program each channel in a sample with a different input range.

- **A/D Converter**—The analog-to-digital converter (ADC) digitizes the AI signal by converting the analog voltage into a digital number.
- **AI FIFO**—M Series devices can perform both single and multiple A/D conversions of a fixed or infinite number of samples. A large first-in-first-out (FIFO) buffer holds data during AI acquisitions to ensure that no data is lost. M Series devices can handle multiple A/D conversion operations with DMA, interrupts, or programmed I/O.

Analog Input Range

Input range refers to the set of input voltages that an analog input channel can digitize with the specified accuracy. The NI-PGIA amplifies or attenuates the AI signal depending on the input range. You can individually program the input range of each AI channel on your M Series device.

The input range affects the resolution of the M Series device for an AI channel. Resolution refers to the voltage of one ADC code. For example, a 16-bit ADC converts analog inputs into one of 65,536 ($= 2^{16}$) codes—that is, one of 65,536 possible digital values. These values are spread fairly evenly across the input range. So, for an input range of -10 V to 10 V, the voltage of each code of a 16-bit ADC is:

$$\frac{10\text{V} - (-10\text{V})}{2^{16}} = 305\mu\text{V}$$

M Series devices use a calibration method that requires some codes (typically about 5% of the codes) to lie outside of the specified range. This calibration method improves absolute accuracy, but it increases the nominal resolution of input ranges by about 5% over what the formula shown above would indicate.

Choose an input range that matches the expected input range of your signal. A large input range can accommodate a large signal variation, but reduces the voltage resolution. Choosing a smaller input range improves the voltage resolution, but may result in the input signal going out of range.

For more information about setting ranges, refer to the *NI-DAQmx Help* or the *LabVIEW Help*.

Table 4-1 shows the input ranges and resolutions supported by each M Series device family.

Table 4-1. M Series Input Range and Nominal Resolution

M Series Devices	Input Range	Nominal Resolution Assuming 5% Over Range
NI 622x	-10 V to 10 V	320 μ V
	-5 V to 5 V	160 μ V
	-1 V to 1 V	32 μ V
	-200 mV to 200 mV	6.4 μ V
NI 625x	-10 V to 10 V	320 μ V
	-5 V to 5 V	160 μ V
	-2 V to 2 V	64 μ V
	-1 V to 1 V	32 μ V
	-500 mV to 500 mV	16 μ V
	-200 mV to 200 mV	6.4 μ V
	-100 mV to 100 mV	3.2 μ V
NI 628x	-10 V to 10 V	80.1 μ V
	-5 V to 5 V	40.1 μ V
	-2 V to 2 V	16.0 μ V
	-1 V to 1 V	8.01 μ V
	-500 mV to 500 mV	4.01 μ V
	-200 mV to 200 mV	1.60 μ V
	-100 mV to 100 mV	0.80 μ V

Analog Input Lowpass Filter

A lowpass filter attenuates signals with frequencies above the cutoff frequency while passing, with minimal attenuation, signals below the cutoff frequency. The cutoff frequency is defined as the frequency at which the output amplitude has decreased by 3 dB. Lowpass filters attenuate noise and reduce aliasing of signals beyond the Nyquist frequency. For example, if the signal of interest does not have frequency components beyond 40 kHz, then using a filter with a cutoff frequency at 40 kHz attenuates noise beyond the cutoff that is not of interest. The cutoff

frequency of the lowpass filter is also called the small signal bandwidth. The specifications document for your DAQ device lists the small signal bandwidth.

On some devices, the filter cutoff is fixed. On other devices, this filter is programmable and can be enabled for a lower frequency. For example, the NI 628x devices have a programmable filter with a cutoff frequency of 40 kHz that can be enabled. If the programmable filter is not enabled, the cutoff frequency is fixed at 750 kHz. If the cutoff is programmable, choose the lower cutoff to reduce measurement noise. However, a filter with a lower cutoff frequency increases the settling time of your device, as shown in the specifications, which reduces its maximum conversion rate. Therefore, you may have to reduce the rate of your AI Convert and AI Sample Clocks. If that reduced sample rate is too slow for your application, select the higher cutoff frequency.

Add additional filters to AI signals using external accessories, as described in the [Programming Devices in Software](#) section of Chapter 2, [DAQ System Overview](#).

Analog Input Ground-Reference Settings

M Series devices support the analog input ground-reference settings:

- **Differential mode**—In DIFF mode, the M Series device measures the difference in voltage between two AI signals.
- **Referenced single-ended mode**—In RSE mode, the M Series device measures the voltage of an AI signal relative to AI GND.
- **Non-referenced single-ended mode**—In NRSE mode, the M Series device measures the voltage of an AI signal relative to one of the AI SENSE or AI SENSE 2 inputs.

The AI ground-reference setting determines how you should connect your AI signals to the M Series device. Refer to the [Connecting Analog Input Signals](#) section for more information.

Ground-reference settings are programmed on a per-channel basis. For example, you might configure the device to scan 12 channels—four differentially-configured channels and eight single-ended channels.

M Series devices implement the different analog input ground-reference settings by routing different signals to the NI-PGIA. The NI-PGIA is a differential amplifier. That is, the NI-PGIA amplifies (or attenuates) the difference in voltage between its two inputs. The NI-PGIA drives the ADC with this amplified voltage. The amount of amplification (the gain), is determined by the analog input range, as shown in Figure 4-2.

Figure 4-2. NI-PGIA

Table 4-2 shows how signals are routed to the NI-PGIA.

Table 4-2. Signals Routed to the NI-PGIA

AI Ground-Reference Settings	Signals Routed to the Positive Input of the NI-PGIA (V_{in+})	Signals Routed to the Negative Input of the NI-PGIA (V_{in-})
RSE	AI <0..79>	AI GND
NRSE	AI <0..15>	AI SENSE
	AI <16..79>	AI SENSE 2*
DIFF	AI <0..7>	AI <8..15>
	AI <16..23>	AI <24..31>
	AI <32..39>	AI <40..47>
	AI <48..55>	AI <56..63>
	AI <64..71>	AI <72..79>

* On NI 6225 devices, the reference for each AI <16..63> signal is AI SENSE 2, and each AI <64..79> signal is AI SENSE in NRSE mode.

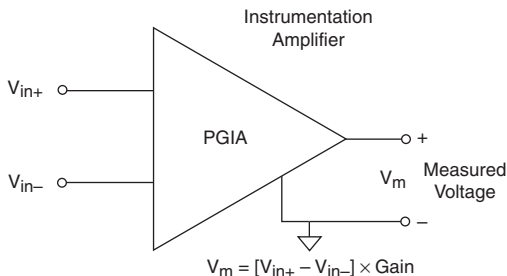
For differential measurements, AI 0 and AI 8 are the positive and negative inputs of differential analog input channel 0. For a complete list of signal pairs that form differential input channels, refer to the pinout diagram for your device in Appendix A, [Module/Device-Specific Information](#).



Caution The maximum input voltages rating of AI signals with respect to ground (and for signal pairs in differential mode with respect to each other) are listed in the specifications document for your device. Exceeding the maximum input voltage of AI signals distorts the measurement results. Exceeding the maximum input voltage rating also can damage the device and the computer. NI is *not* liable for any damage resulting from such signal connections.

AI ground-reference setting is sometimes referred to as AI terminal configuration.

Configuring AI Ground-Reference Settings in Software

You can program channels on an M Series device to acquire with different ground references.

To enable multimode scanning in LabVIEW, use the NI-DAQmx Create Virtual Channel VI of the NI-DAQmx API. You must use a new VI for each channel or group of channels configured in a different input mode. In Figure 4-3, channel 0 is configured in differential mode, and channel 1 is configured in referenced single-ended mode.

Figure 4-3. Enabling Multimode Scanning in LabVIEW

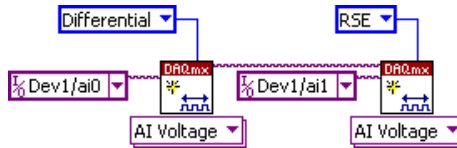

To configure the input mode of your voltage measurement using the DAQ Assistant, use the **Terminal Configuration** drop-down list. Refer to the *DAQ Assistant Help* for more information about the DAQ Assistant.

To configure the input mode of your voltage measurement using the NI-DAQmx C API, set the **terminalConfig** property. Refer to the *NI-DAQmx C Reference Help* for more information.

Multichannel Scanning Considerations

M Series devices can scan multiple channels at high rates and digitize the signals accurately. However, you should consider several issues when designing your measurement system to ensure the high accuracy of your measurements.

In multichannel scanning applications, accuracy is affected by settling time. When your M Series device switches from one AI channel to another AI channel, the device configures the NI-PGIA with the input range of the new channel. The NI-PGIA then amplifies the input signal with the gain for the new input range. Settling time refers to the time it takes the NI-PGIA to amplify the input signal to the desired accuracy before it is sampled by the ADC. The specifications document for your DAQ device lists its settling time.

M Series devices are designed to have fast settling times. However, several factors can increase the settling time which decreases the accuracy of your measurements. To ensure fast settling times, you should do the following (in order of importance):

1. **Use Low Impedance Sources**—To ensure fast settling times, your signal sources should have an impedance of <1 k Ω . Large source impedances increase the settling time of the NI-PGIA, and so decrease the accuracy at fast scanning rates.

Settling times increase when scanning high-impedance signals due to a phenomenon called charge injection. Multiplexers contain switches, usually made of switched capacitors. When one of the channels, for example channel 0, is selected in a multiplexer, those capacitors accumulate charge. When the next channel, for example channel 1, is selected, the accumulated charge leaks backward through channel 1. If the output impedance of the source connected to channel 1 is high enough, the resulting reading of channel 1 can be partially affected by the voltage on channel 0. This effect is referred to as ghosting.

If your source impedance is high, you can decrease the scan rate to allow the NI-PGIA more time to settle. Another option is to use a voltage follower circuit external to your DAQ device to decrease the impedance seen by the DAQ device. Refer to the KnowledgeBase document, *Decreasing the Source Impedance of an Analog Input Signal*, by going to ni.com/info and entering the Info Code `rdbbis`.

2. **Use Short High-Quality Cabling**—Using short high-quality cables can minimize several effects that degrade accuracy including crosstalk, transmission line effects, and noise. The capacitance of the cable also can increase the settling time.

National Instruments recommends using individually shielded, twisted-pair wires that are 2 m or less to connect AI signals to the device. Refer to the *Connecting Analog Input Signals* section for more information.

3. **Carefully Choose the Channel Scanning Order**

- Avoid Switching from a Large to a Small Input Range—Switching from a channel with a large input range to a channel with a small input range can greatly increase the settling time.

Suppose a 4 V signal is connected to channel 0 and a 1 mV signal is connected to channel 1. The input range for channel 0 is -10 V to 10 V and the input range of channel 1 is -200 mV to 200 mV.

When the multiplexer switches from channel 0 to channel 1, the input to the NI-PGIA switches from 4 V to 1 mV. The approximately 4 V step from 4 V to 1 mV is 1,000% of the new full-scale range. For a 16-bit device to settle within 0.0015% (15 ppm or 1 LSB) of the ± 200 mV full-scale range on channel 1, the input circuitry must settle to within 0.000031% (0.31 ppm or 1/50 LSB) of the ± 10 V range. Some devices can take many microseconds for the circuitry to settle this much.

To avoid this effect, you should arrange your channel scanning order so that transitions from large to small input ranges are infrequent.

In general, you do not need this extra settling time when the NI-PGIA is switching from a small input range to a larger input range.

- Insert Grounded Channel between Signal Channels—Another technique to improve settling time is to connect an input channel to ground. Then insert this channel in the scan list between two of your signal channels. The input range of the grounded channel should match the input range of the signal after the grounded channel in the scan list.

Consider again the example above where a 4 V signal is connected to channel 0 and a 1 mV signal is connected to channel 1. Suppose the input range for channel 0 is -10 V to 10 V and the input range of channel 1 is -200 mV to 200 mV.

You can connect channel 2 to AI GND (or you can use the internal ground; refer to *Internal Channels* in the *NI-DAQmx Help*). Set the input range of channel 2 to -200 mV to 200 mV to match channel 1. Then scan channels in the order: 0, 2, 1.

Inserting a grounded channel between signal channels improves settling time because the NI-PGIA adjusts to the new input range setting faster when the input is grounded.

- Minimize Voltage Step between Adjacent Channels—When scanning between channels that have the same input range, the settling time increases with the voltage step between the channels. If you know the expected input range of your signals, you can group signals with similar expected ranges together in your scan list.

For example, suppose all channels in a system use a -5 to 5 V input range. The signals on channels 0, 2, and 4 vary between 4.3 V and 5 V. The signals on channels 1, 3, and 5 vary between -4 V and 0 V. Scanning channels in the order 0, 2, 4, 1, 3, 5 produces more accurate results than scanning channels in the order 0, 1, 2, 3, 4, 5.

4. **Avoid Scanning Faster Than Necessary**—Designing your system to scan at slower speeds gives the NI-PGIA more time to settle to a more accurate level. Here are two examples to consider:

- Example 1—Averaging many AI samples can increase the accuracy of the reading by decreasing noise effects. In general, the more points you average, the more accurate the final result. However, you may choose to decrease the number of points you average and slow down the scanning rate.

Suppose you want to sample 10 channels over a period of 20 ms and average the results. You could acquire 500 points from each channel at a scan rate of 250 kS/s. Another method would be to acquire 1,000 points from each channel at a scan rate of 500 kS/s. Both methods take the same amount of time. Doubling the number of samples averaged (from 500 to 1,000) decreases the effect of noise by a factor of 1.4 (the square root of 2). However, doubling the number of samples (in this example) decreases the time the NI-PGIA has to settle from 4 μ s to 2 μ s. In some cases, the slower scan rate system returns more accurate results.

- Example 2—If the time relationship between channels is not critical, you can sample from the same channel multiple times and scan less frequently. For example, suppose an application requires averaging 100 points from channel 0 and averaging 100 points from channel 1. You could alternate reading between channels—that is, read one point from channel 0, then one point from channel 1, and so on. You also could read all 100 points from channel 0 then read 100 points from channel 1. The second method switches between channels much less often and is affected much less by settling time.

Analog Input Data Acquisition Methods

When performing analog input measurements, you either can perform software-timed or hardware-timed acquisitions.

Software-Timed Acquisitions

With a software-timed acquisition, software controls the rate of the acquisition. Software sends a separate command to the hardware to initiate each ADC conversion. In NI-DAQmx, software-timed acquisitions are referred to as having on-demand timing. Software-timed acquisitions are also referred to as immediate or static acquisitions and are typically used for reading a single sample of data.

Hardware-Timed Acquisitions

With hardware-timed acquisitions, a digital hardware signal (AI Sample Clock) controls the rate of the acquisition. This signal can be generated internally on your device or provided externally.

Hardware-timed acquisitions have several advantages over software-timed acquisitions:

- The time between samples can be much shorter.
- The timing between samples is deterministic.
- Hardware-timed acquisitions can use hardware triggering.

Hardware-timed operations can be buffered or non-buffered. A buffer is a temporary storage in computer memory for to-be-generated samples.

- **Buffered**—In a buffered acquisition, data is moved from the DAQ device's onboard FIFO memory to a PC buffer using DMA or interrupts before it is transferred to application memory. Buffered acquisitions typically allow for much faster transfer rates than non-buffered acquisitions because data is moved in large blocks, rather than one point at a time.

One property of buffered I/O operations is the sample mode. The sample mode can be either finite or continuous.

- Finite sample mode acquisition refers to the acquisition of a specific, predetermined number of data samples. Once the specified number of samples has been read in, the acquisition stops. If you use a reference trigger, you must use finite sample mode.
- Continuous acquisition refers to the acquisition of an unspecified number of samples. Instead of acquiring a set number of data samples and stopping, a continuous acquisition continues until you stop the operation. Continuous acquisition is also referred to as double-buffered or circular-buffered acquisition.

If data cannot be transferred across the bus fast enough, the FIFO becomes full. New acquisitions overwrite data in the FIFO before it can be transferred to host memory. The device generates an error in this case. With continuous operations, if the user program does not read data out of the PC buffer fast enough to keep up with the data transfer, the buffer could reach an overflow condition, causing an error to be generated.

- **Non-buffered**—In non-buffered acquisitions, data is read directly from the FIFO on the device. Typically, hardware-timed, non-buffered operations are used to read single samples with known time increments between them.



Note (NI USB-62xx Devices) USB M Series devices do not support non-buffered hardware-timed operations.

Analog Input Triggering

Analog input supports three different triggering actions:

- Start trigger
- Reference trigger
- Pause trigger

Refer to the *AI Start Trigger Signal*, *AI Reference Trigger Signal*, and *AI Pause Trigger Signal* sections for information about these triggers.

An analog or digital trigger can initiate these actions. All M Series devices support digital triggering, but some do not support analog triggering. To find your device triggering options, refer to the specifications document for your device.

Connecting Analog Input Signals

Table 4-3 summarizes the recommended input configuration for both types of signal sources.

Table 4-3. Analog Input Configuration

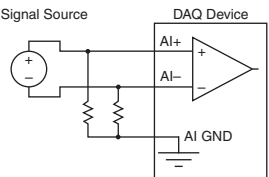
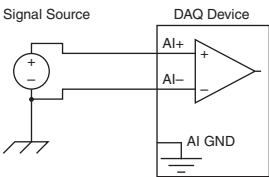
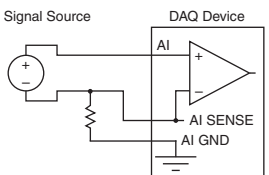
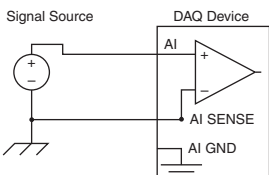
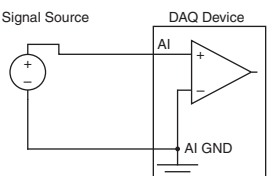
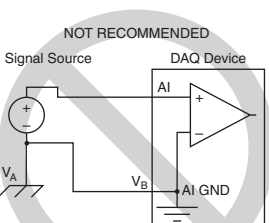
AI Ground-Reference Setting*	Floating Signal Sources (Not Connected to Building Ground)	Ground-Referenced Signal Sources†
		Examples: <ul style="list-style-type: none"> • Ungrounded thermocouples • Signal conditioning with isolated outputs • Battery devices
Differential (DIFF)		
Non-Referenced Single-Ended (NRSE)		
Referenced Single-Ended (RSE)		<p style="text-align: center;">NOT RECOMMENDED</p>  <p style="text-align: center;">Ground-loop potential ($V_A - V_B$) are added to measured signal.</p>
<p>* Refer to the Analog Input Ground-Reference Settings section for descriptions of the RSE, NRSE, and DIFF modes and software considerations.</p> <p>† Refer to the Connecting Ground-Referenced Signal Sources section for more information.</p>		

Connecting Floating Signal Sources

What Are Floating Signal Sources?

A floating signal source is not connected to the building ground system, but has an isolated ground-reference point. Some examples of floating signal sources are outputs of transformers, thermocouples, battery-powered devices, optical isolators, and isolation amplifiers. An instrument or device that has an isolated output is a floating signal source.

When to Use Differential Connections with Floating Signal Sources

Use DIFF input connections for any channel that meets any of the following conditions:

- The input signal is low level (less than 1 V).
- The leads connecting the signal to the device are greater than 3 m (10 ft).
- The input signal requires a separate ground-reference point or return signal.
- The signal leads travel through noisy environments.
- Two analog input channels, AI+ and AI-, are available for the signal.

DIFF signal connections reduce noise pickup and increase common-mode noise rejection. DIFF signal connections also allow input signals to float within the common-mode limits of the NI-PGIA.

Refer to the [Using Differential Connections for Floating Signal Sources](#) section for more information about differential connections.

When to Use Non-Referenced Single-Ended (NRSE) Connections with Floating Signal Sources

Only use NRSE input connections if the input signal meets the following conditions:

- The input signal is high-level (greater than 1 V).
- The leads connecting the signal to the device are less than 3 m (10 ft).

DIFF input connections are recommended for greater signal integrity for any input signal that does not meet the preceding conditions.

In the single-ended modes, more electrostatic and magnetic noise couples into the signal connections than in DIFF configurations. The coupling is the result of differences in the signal path. Magnetic coupling is proportional to the area between the two signal conductors. Electrical coupling is a function of how much the electric field differs between the two conductors.

With this type of connection, the NI-PGIA rejects both the common-mode noise in the signal and the ground potential difference between the signal source and the device ground.

Refer to the [Using Non-Referenced Single-Ended \(NRSE\) Connections for Floating Signal Sources](#) section for more information about NRSE connections.

When to Use Referenced Single-Ended (RSE) Connections with Floating Signal Sources

Only use RSE input connections if the input signal meets the following conditions:

- The input signal can share a common reference point, AI GND, with other signals that use RSE.
- The input signal is high-level (greater than 1 V).
- The leads connecting the signal to the device are less than 3 m (10 ft).

DIFF input connections are recommended for greater signal integrity for any input signal that does not meet the preceding conditions.

In the single-ended modes, more electrostatic and magnetic noise couples into the signal connections than in DIFF configurations. The coupling is the result of differences in the signal path. Magnetic coupling is proportional to the area between the two signal conductors. Electrical coupling is a function of how much the electric field differs between the two conductors.

With this type of connection, the NI-PGIA rejects both the common-mode noise in the signal and the ground potential difference between the signal source and the device ground.

Refer to the [Using Referenced Single-Ended \(RSE\) Connections for Floating Signal Sources](#) section for more information about RSE connections.

Using Differential Connections for Floating Signal Sources

It is important to connect the negative lead of a floating source to AI GND (either directly or through a bias resistor). Otherwise, the source may float out of the maximum working voltage range of the NI-PGIA and the DAQ device returns erroneous data.

The easiest way to reference the source to AI GND is to connect the positive side of the signal to AI+ and connect the negative side of the signal to AI GND as well as to AI- without using resistors. This connection works well for DC-coupled sources with low source impedance (less than 100 Ω).



Note (NI USB-62xx BNC Devices) To measure a floating signal source on USB BNC devices, move the switch under the BNC connector to the FS position.

Figure 4-4. Differential Connections for Floating Signal Sources without Bias Resistors

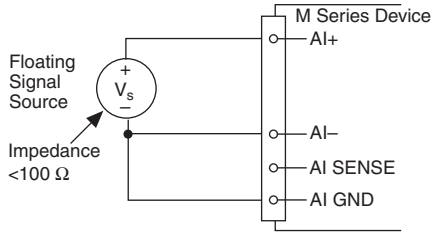

However, for larger source impedances, this connection leaves the DIFF signal path significantly off balance. Noise that couples electrostatically onto the positive line does not couple onto the negative line because it is connected to ground. This noise appears as a DIFF-mode signal instead of a common-mode signal, and thus appears in your data. In this case, instead of directly connecting the negative line to AI GND, connect the negative line to AI GND through a resistor that is about 100 times the equivalent source impedance. The resistor puts the signal path nearly in balance, so that about the same amount of noise couples onto both connections, yielding better rejection of electrostatically coupled noise. This configuration does not load down the source (other than the very high input impedance of the NI-PGIA).

Figure 4-5. Differential Connections for Floating Signal Sources with Single Bias Resistor

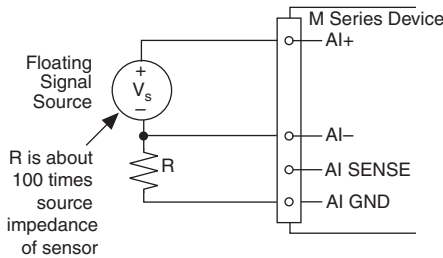

You can fully balance the signal path by connecting another resistor of the same value between the positive input and AI GND, as shown in Figure 4-6. This fully balanced configuration offers slightly better noise rejection, but has the disadvantage of loading the source down with the series combination (sum) of the two resistors. If, for example, the source impedance is 2 k Ω and each of the two resistors is 100 k Ω , the resistors load down the source with 200 k Ω and produce a -1% gain error.

Figure 4-6. Differential Connections for Floating Signal Sources with Balanced Bias Resistors

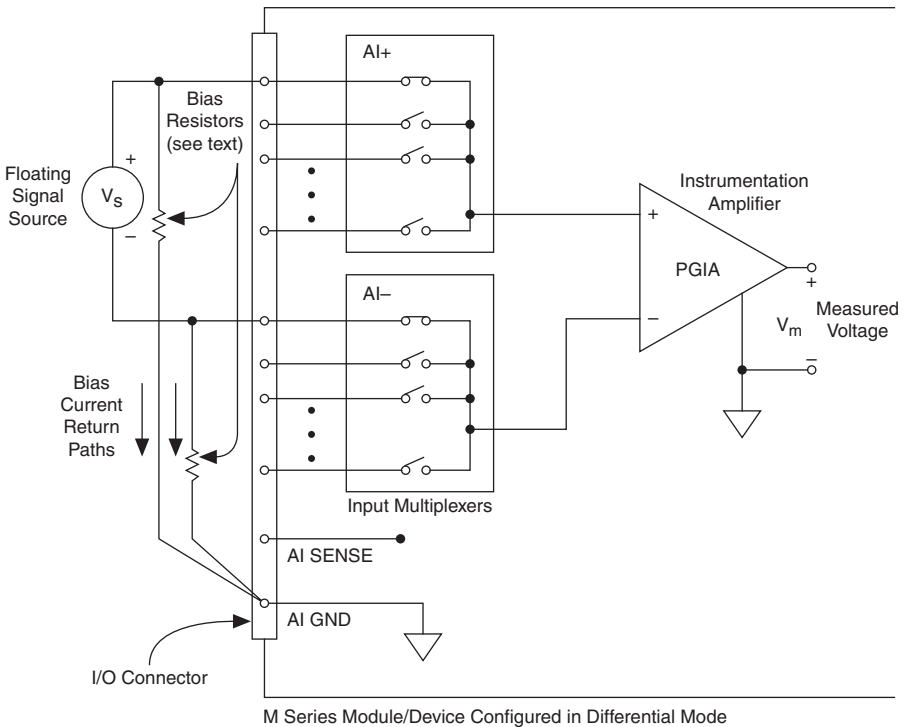

Both inputs of the NI-PGIA require a DC path to ground in order for the NI-PGIA to work. If the source is AC coupled (capacitively coupled), the NI-PGIA needs a resistor between the positive input and AI GND. If the source has low-impedance, choose a resistor that is large enough not to significantly load the source but small enough not to produce significant input offset voltage as a result of input bias current (typically 100 k Ω to 1 M Ω). In this case, connect the negative input directly to AI GND. If the source has high output impedance, balance the signal path as previously described using the same value resistor on both the positive and negative inputs; be aware that there is some gain error from loading down the source, as shown in Figure 4-7.

Figure 4-7. Differential Connections for AC Coupled Floating Sources with Balanced Bias Resistors

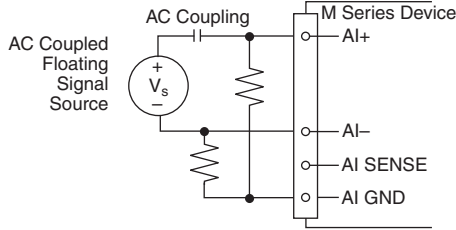

Using Non-Referenced Single-Ended (NRSE) Connections for Floating Signal Sources

It is important to connect the negative lead of a floating signals source to AI GND (either directly or through a resistor). Otherwise the source may float out of the valid input range of the NI-PGIA and the DAQ device returns erroneous data.



Note (NI USB-62xx BNC Devices) To measure a floating signal source on USB BNC devices, move the switch under the BNC connector to the FS position.

Figure 4-8 shows a floating source connected to the DAQ device in NRSE mode.

Figure 4-8. NRSE Connections for Floating Signal Sources

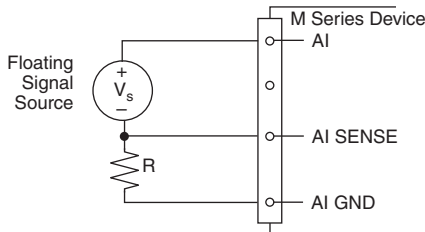

All of the bias resistor configurations discussed in the [Using Differential Connections for Floating Signal Sources](#) section apply to the NRSE bias resistors as well. Replace AI- with AI SENSE in Figures 4-4, 4-5, 4-6, and 4-7 for configurations with zero to two bias resistors. The noise rejection of NRSE mode is better than RSE mode because the AI SENSE connection is made remotely near the source. However, the noise rejection of NRSE mode is worse than DIFF mode because the AI SENSE connection is shared with all channels rather than being cabled in a twisted pair with the AI+ signal.

Using the DAQ Assistant, you can configure the channels for RSE or NRSE input modes. Refer to the [Configuring AI Ground-Reference Settings in Software](#) section for more information about the DAQ Assistant.

Using Referenced Single-Ended (RSE) Connections for Floating Signal Sources

Figure 4-9 shows how to connect a floating signal source to the M Series device configured for RSE mode.

Figure 4-9. RSE Connections for Floating Signal Sources

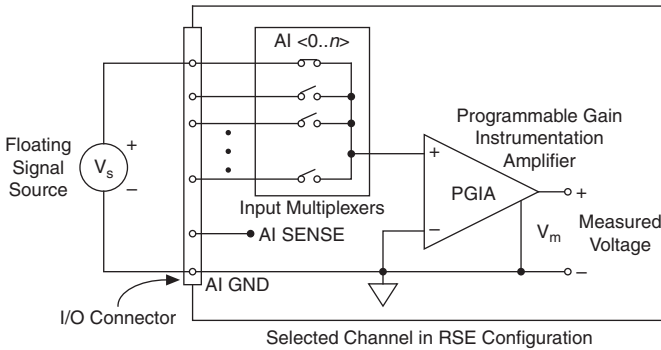

Note (NI USB-62xx BNC Devices) To measure a floating signal source on USB BNC devices, move the switch under the BNC connector to the FS position.

Using the DAQ Assistant, you can configure the channels for RSE or NRSE input modes. Refer to the [Configuring AI Ground-Reference Settings in Software](#) section for more information about the DAQ Assistant.

Connecting Ground-Referenced Signal Sources

What Are Ground-Referenced Signal Sources?

A ground-referenced signal source is a signal source connected to the building system ground. It is already connected to a common ground point with respect to the device, assuming that the computer is plugged into the same power system as the source. Non-isolated outputs of instruments and devices that plug into the building power system fall into this category.

The difference in ground potential between two instruments connected to the same building power system is typically between 1 and 100 mV, but the difference can be much higher if power distribution circuits are improperly connected. If a grounded signal source is incorrectly measured, this difference can appear as measurement error. Follow the connection instructions for grounded signal sources to eliminate this ground potential difference from the measured signal.

When to Use Differential Connections with Ground-Referenced Signal Sources

Use DIFF input connections for any channel that meets any of the following conditions:

- The input signal is low level (less than 1 V).
- The leads connecting the signal to the device are greater than 3 m (10 ft).
- The input signal requires a separate ground-reference point or return signal.
- The signal leads travel through noisy environments.
- Two analog input channels, AI+ and AI-, are available.

DIFF signal connections reduce noise pickup and increase common-mode noise rejection. DIFF signal connections also allow input signals to float within the common-mode limits of the NI-PGIA.

Refer to the [Using Differential Connections for Ground-Referenced Signal Sources](#) section for more information about differential connections.

When to Use Non-Referenced Single-Ended (NRSE) Connections with Ground-Referenced Signal Sources

Only use non-referenced single-ended input connections if the input signal meets the following conditions:

- The input signal is high-level (greater than 1 V).
- The leads connecting the signal to the device are less than 3 m (10 ft).
- The input signal can share a common reference point with other signals.

DIFF input connections are recommended for greater signal integrity for any input signal that does not meet the preceding conditions.

In the single-ended modes, more electrostatic and magnetic noise couples into the signal connections than in DIFF configurations. The coupling is the result of differences in the signal path. Magnetic coupling is proportional to the area between the two signal conductors. Electrical coupling is a function of how much the electric field differs between the two conductors.

With this type of connection, the NI-PGIA rejects both the common-mode noise in the signal and the ground potential difference between the signal source and the device ground.

Refer to the [Using Non-Referenced Single-Ended \(NRSE\) Connections for Ground-Referenced Signal Sources](#) section for more information about NRSE connections.

When to Use Referenced Single-Ended (RSE) Connections with Ground-Referenced Signal Sources

Do *not* use RSE connections with ground-referenced signal sources. Use NRSE or DIFF connections instead.

As shown in the bottom-rightmost cell of Table 4-3, there can be a potential difference between AI GND and the ground of the sensor. In RSE mode, this ground loop causes measurement errors.

Using Differential Connections for Ground-Referenced Signal Sources

Figure 4-10 shows how to connect a ground-referenced signal source to the M Series device configured in DIFF mode.

Figure 4-10. Differential Connections for Ground-Referenced Signal Sources

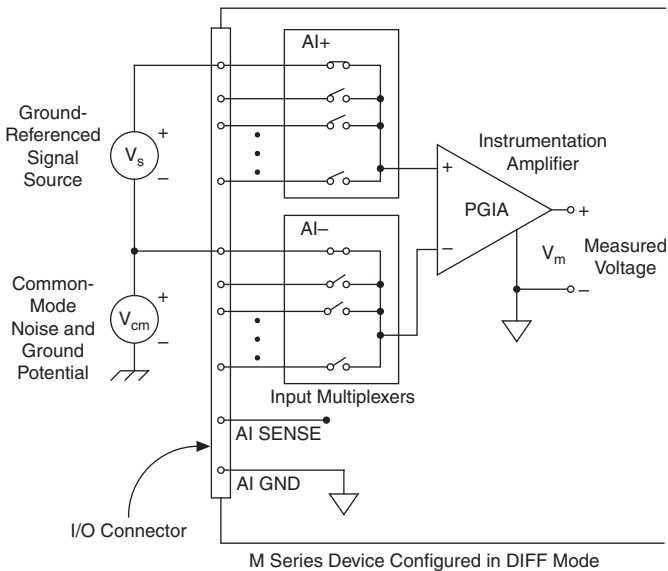

Note (NI USB-62xx BNC Devices) To measure a ground-referenced signal source on USB BNC devices, move the switch under the BNC connector to the GS position.

With this type of connection, the NI-PGIA rejects both the common-mode noise in the signal and the ground potential difference between the signal source and the device ground, shown as V_{cm} in the figure.

AI+ and AI- must both remain within ± 11 V of AI GND.

Using Non-Referenced Single-Ended (NRSE) Connections for Ground-Referenced Signal Sources

Figure 4-11 shows how to connect ground-reference signal sources in NRSE mode.

Figure 4-11. Single-Ended Connections for Ground-Referenced Signal Sources (NRSE Configuration)

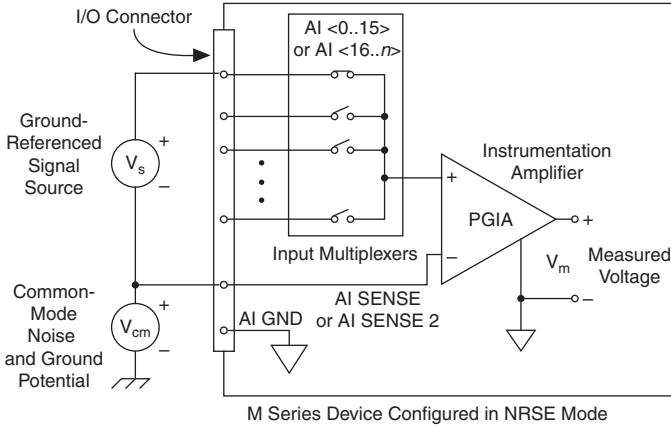

Note (NI USB-62xx BNC Devices) To measure a ground-referenced signal source on USB BNC devices, move the switch under the BNC connector to the GS position.

AI+ and AI- must both remain within ± 11 V of AI GND.

To measure a single-ended, ground-referenced signal source, you must use the NRSE ground-reference setting. Connect the signal to an AI terminal and connect the signal local ground reference to its AI SENSE. AI SENSE and AI SENSE 2 are internally connected to the negative input of the NI-PGIA. Therefore, the ground point of the signal connects to the negative input of the NI-PGIA.

Any potential difference between the device ground and the signal ground appears as a common-mode signal at both the positive and negative inputs of the NI-PGIA, and this difference is rejected by the amplifier. If the input circuitry of a device were referenced to ground, as it is in the RSE ground-reference setting, this difference in ground potentials would appear as an error in the measured voltage.

Using the DAQ Assistant, you can configure the channels for RSE or NRSE input modes. Refer to the [Configuring AI Ground-Reference Settings in Software](#) section for more information about the DAQ Assistant.

Field Wiring Considerations

Environmental noise can seriously affect the measurement accuracy of the device if you do not take proper care when running signal wires between signal sources and the device. The following recommendations apply mainly to AI signal routing to the device, although they also apply to signal routing in general.

Minimize noise pickup and maximize measurement accuracy by taking the following precautions:

- Use DIFF AI connections to reject common-mode noise.
- Use individually shielded, twisted-pair wires to connect AI signals to the device. With this type of wire, the signals attached to the positive and negative input channels are twisted together and then covered with a shield. You then connect this shield only at one point to the signal source ground. This kind of connection is required for signals traveling through areas with large magnetic fields or high electromagnetic interference.

Refer to the *Field Wiring and Noise Considerations for Analog Signals* document for more information. To access this document, go to ni.com/info and enter the Info Code `rdfwn3`.

Analog Input Timing Signals

In order to provide all of the timing functionality described throughout this section, M Series devices have a flexible timing engine. Figure 4-12 summarizes all of the timing options provided by the analog input timing engine. Also refer to the *Clock Routing* section of Chapter 9, *Digital Routing and Clock Generation*.

Figure 4-12. Analog Input Timing Options

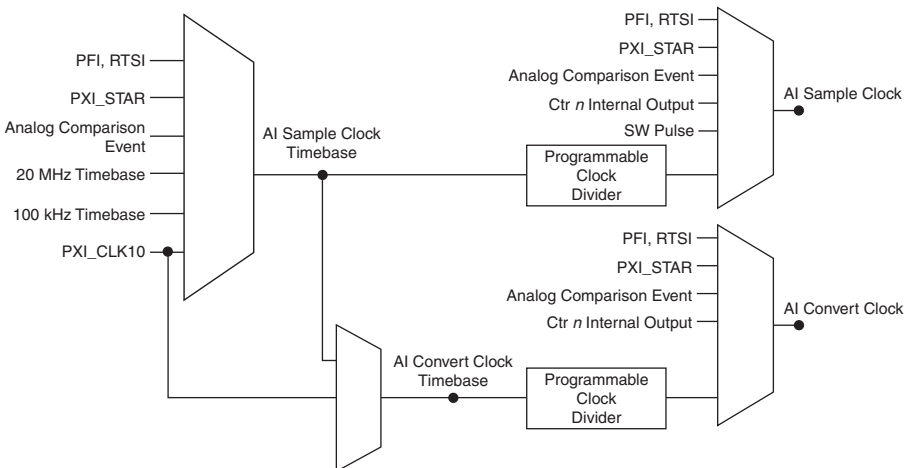

M Series devices use AI Sample Clock (ai/SampleClock) and AI Convert Clock (ai/ConvertClock) to perform interval sampling. As Figure 4-13 shows, AI Sample Clock (ai/SampleClock) controls the sample period, which is determined by the following equation:

$$1/\text{Sample Period} = \text{Sample Rate}$$

Figure 4-13. Interval Sampling

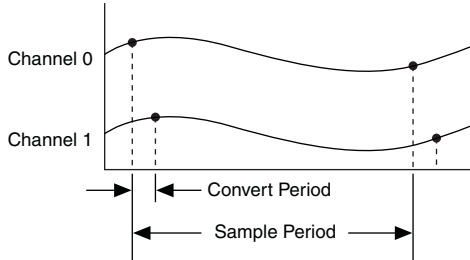

AI Convert Clock controls the Convert Period, which is determined by the following equation:

$$1/\text{Convert Period} = \text{Convert Rate}$$

Typically, this rate is the sampling rate for the task multiplied by the number of channels in the task.



Note The sampling rate is the fastest you can acquire data on the device and still achieve accurate results. For example, if an M Series device has a sampling rate of 250 kS/s, this sampling rate is aggregate—one channel at 250 kS/s or two channels at 125 kS/s per channel illustrates the relationship.

Posttriggered data acquisition allows you to view only data that is acquired after a trigger event is received. A typical posttriggered DAQ sequence is shown in Figure 4-14. The sample counter is loaded with the specified number of posttrigger samples, in this example, five. The value decrements with each pulse on AI Sample Clock, until all desired samples have been acquired.

Figure 4-14. Posttriggered Data Acquisition Example

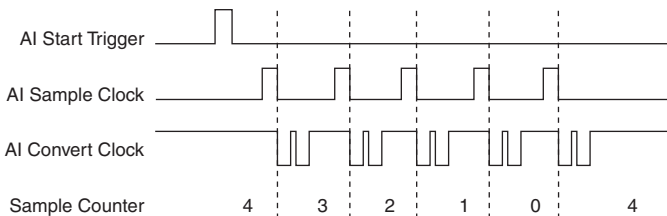

Pretriggered data acquisition allows you to view data that is acquired before the trigger of interest, in addition to data acquired after the trigger. Figure 4-15 shows a typical pretriggered DAQ sequence. AI Start Trigger (ai/StartTrigger) can be either a hardware or software signal. If

AI Start Trigger is set up to be a software start trigger, an output pulse appears on the ai/StartTrigger line when the acquisition begins. When the AI Start Trigger pulse occurs, the sample counter is loaded with the number of pretriggered samples, in this example, four. The value decrements with each pulse on AI Sample Clock. The sample counter is then loaded with the number of posttriggered samples, in this example, three.

Figure 4-15. Pretriggered Data Acquisition Example

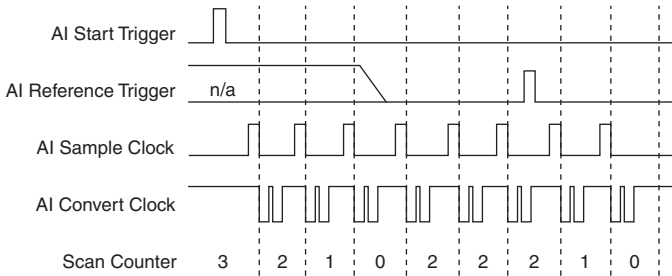

If an AI Reference Trigger (ai/ReferenceTrigger) pulse occurs before the specified number of pretrigger samples are acquired, the trigger pulse is ignored. Otherwise, when the AI Reference Trigger pulse occurs, the sample counter value decrements until the specified number of posttrigger samples have been acquired.

M Series devices feature the following analog input timing signals:

- *AI Sample Clock Signal*
- *AI Sample Clock Timebase Signal*
- *AI Convert Clock Signal*
- *AI Convert Clock Timebase Signal*
- *AI Hold Complete Event Signal*
- *AI Start Trigger Signal*
- *AI Reference Trigger Signal*
- *AI Pause Trigger Signal*

AI Sample Clock Signal

Use the AI Sample Clock (ai/SampleClock) signal to initiate a set of measurements. Your M Series device samples the AI signals of every channel in the task once for every AI Sample Clock. A measurement acquisition consists of one or more samples.

You can specify an internal or external source for AI Sample Clock. You also can specify whether the measurement sample begins on the rising edge or falling edge of AI Sample Clock.

Using an Internal Source

One of the following internal signals can drive AI Sample Clock:

- Counter n Internal Output
- AI Sample Clock Timebase (divided down)
- A pulse initiated by host software

A programmable internal counter divides down the sample clock timebase.

Several other internal signals can be routed to AI Sample Clock through RTSI. Refer to *Device Routing in MAX* in the *NI-DAQmx Help* or the *LabVIEW Help* for more information.

Using an External Source

Use one of the following external signals as the source of AI Sample Clock:

- PFI <0..15>
- RTSI <0..7>
- PXI_STAR
- Analog Comparison Event (an analog trigger)

Routing AI Sample Clock Signal to an Output Terminal

You can route AI Sample Clock out to any PFI <0..15> or RTSI <0..7> terminal. This pulse is always active high.

You can specify the output to have one of two behaviors. With the pulse behavior, your DAQ device briefly pulses the PFI terminal once for every occurrence of AI Sample Clock.

With level behavior, your DAQ device drives the PFI terminal high during the entire sample.

All PFI terminals are configured as inputs by default.

Other Timing Requirements

Your DAQ device only acquires data during an acquisition. The device ignores AI Sample Clock when a measurement acquisition is not in progress. During a measurement acquisition, you can cause your DAQ device to ignore AI Sample Clock using the AI Pause Trigger signal.

A counter on your device internally generates AI Sample Clock unless you select some external source. AI Start Trigger starts this counter and either software or hardware can stop it once a finite acquisition completes. When using an internally generated AI Sample Clock, you also can specify a configurable delay from AI Start Trigger to the first AI Sample Clock pulse. By default, this delay is set to two ticks of the AI Sample Clock Timebase signal. When using an externally generated AI Sample Clock, you must ensure the clock signal is consistent with respect to the timing requirements of AI Convert Clock. Failure to do so may result in AI Sample Clock pulses that are masked off and acquisitions with erratic sampling intervals. Refer to AI Convert Clock Signal for more information about the timing requirements between AI Convert Clock and AI Sample Clock.

Figure 4-16 shows the relationship of AI Sample Clock to AI Start Trigger.

Figure 4-16. AI Sample Clock and AI Start Trigger

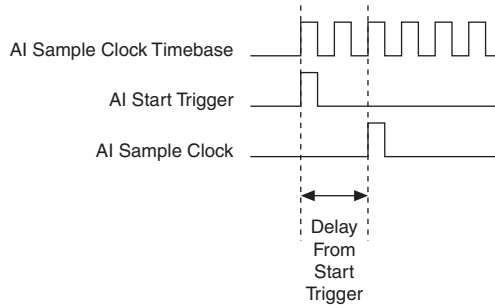

AI Sample Clock Timebase Signal

You can route any of the following signals to be the AI Sample Clock Timebase (ai/SampleClockTimebase) signal:

- 20 MHz Timebase
- 100 kHz Timebase
- PXI_CLK10
- RTSI <0..7>
- PFI <0..15>
- PXI_STAR
- Analog Comparison Event (an analog trigger)

AI Sample Clock Timebase is not available as an output on the I/O connector. AI Sample Clock Timebase is divided down to provide one of the possible sources for AI Sample Clock. You can configure the polarity selection for AI Sample Clock Timebase as either rising or falling edge.

AI Convert Clock Signal

Use the AI Convert Clock (ai/ConvertClock) signal to initiate a single A/D conversion on a single channel. A sample (controlled by the AI Sample Clock) consists of one or more conversions.

You can specify either an internal or external signal as the source of AI Convert Clock. You also can specify whether the measurement sample begins on the rising edge or falling edge of AI Convert Clock.

NI-DAQmx chooses the fastest conversion rate possible based on the speed of the A/D converter and adds 10 μ s of padding between each channel to allow for adequate settling time. This scheme enables the channels to approximate simultaneous sampling and still allow for adequate settling time. If the AI Sample Clock rate is too fast to allow for this 10 μ s of padding, NI-DAQmx chooses the conversion rate so that the AI Convert Clock pulses are evenly spaced throughout the sample.

To explicitly specify the conversion rate, use **AI Convert Clock Rate DAQmx Timing** property node or function.



Note Setting the conversion rate higher than the maximum rate specified for your device will result in errors.

Using an Internal Source

One of the following internal signals can drive AI Convert Clock:

- AI Convert Clock Timebase (divided down)
- Counter n Internal Output

A programmable internal counter divides down the AI Convert Clock Timebase to generate AI Convert Clock. The counter is started by AI Sample Clock and continues to count down to zero, produces an AI Convert Clock, reloads itself, and repeats the process until the sample is finished. It then reloads itself in preparation for the next AI Sample Clock pulse.

Using an External Source

Use one of the following external signals as the source of AI Convert Clock:

- PFI <0..15>
- RTSI <0..7>
- PXI_STAR
- Analog Comparison Event (an analog trigger)

Routing AI Convert Clock Signal to an Output Terminal

You can route AI Convert Clock (as an active low signal) out to any PFI <0..15> or RTSI <0..7> terminal.

All PFI terminals are configured as inputs by default.

Using a Delay from Sample Clock to Convert Clock

When using an internally generated AI Convert Clock, you also can specify a configurable delay from AI Sample Clock to the first AI Convert Clock pulse within the sample. By default, this delay is three ticks of AI Convert Clock Timebase.

Figure 4-17 shows the relationship of AI Sample Clock to AI Convert Clock.

Figure 4-17. AI Sample Clock and AI Convert Clock

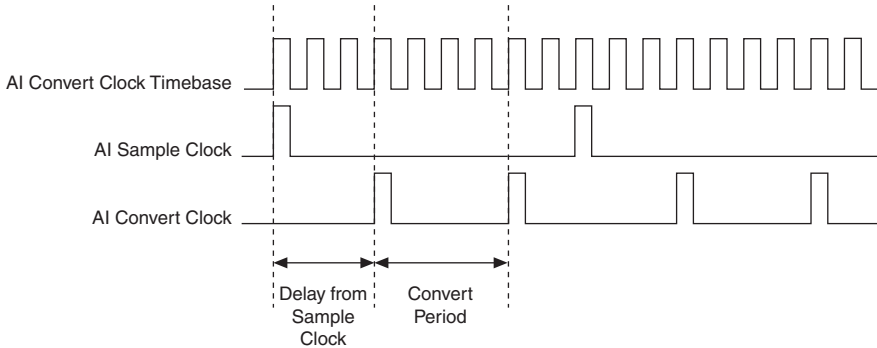

Other Timing Requirements

The sample and conversion level timing of M Series devices work such that clock signals are gated off unless the proper timing requirements are met. For example, the device ignores both AI Sample Clock and AI Convert Clock until it receives a valid AI Start Trigger signal. Once the device recognizes an AI Sample Clock pulse, it ignores subsequent AI Sample Clock pulses until it receives the correct number of AI Convert Clock pulses.

Similarly, the device ignores all AI Convert Clock pulses until it recognizes an AI Sample Clock pulse. Once the device receives the correct number of AI Convert Clock pulses, it ignores subsequent AI Convert Clock pulses until it receives another AI Sample Clock. Figures 4-18, 4-19, 4-20, and 4-21 show timing sequences for a four-channel acquisition (using AI channels 0, 1, 2, and 3) and demonstrate proper and improper sequencing of AI Sample Clock and AI Convert Clock.

Figure 4-18. AI Sample Clock Pulses Are Gated Off; AI Sample Clock Too Fast For Convert Clock

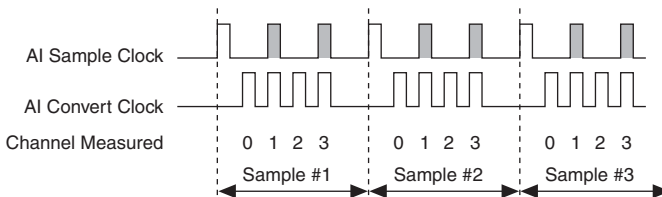

Figure 4-19. AI Convert Clock Too Fast For AI Sample Clock; AI Convert Clock Pulses Are Gated Off

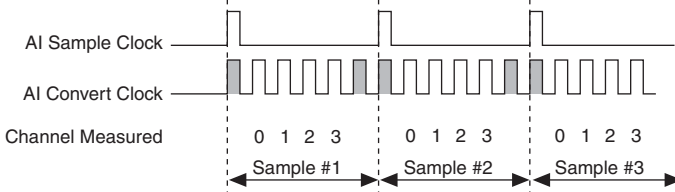

Figure 4-20. AI Sample Clock and AI Convert Clock Improperly Matched; Leads to Aperiodic Sampling

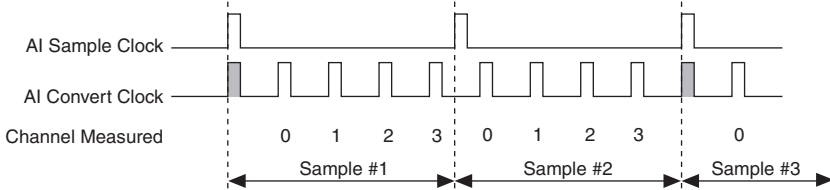
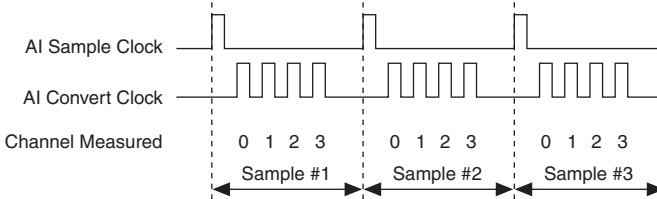
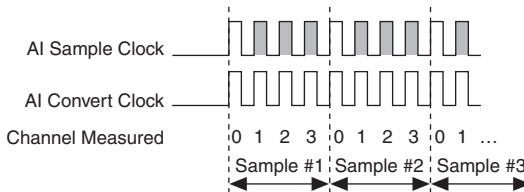

Figure 4-21. AI Sample Clock and AI Convert Clock Properly Matched



It is also possible to use a single external signal to drive both AI Sample Clock and AI Convert Clock at the same time. In this mode, each tick of the external clock causes a conversion on the ADC. Figure 4-22 shows this timing relationship.

Figure 4-22. One External Signal Driving Both Clocks Simultaneously



AI Convert Clock Timebase Signal

The AI Convert Clock Timebase (`ai/ConvertClockTimebase`) signal is divided down to provide one of the possible sources for AI Convert Clock. Use one of the following signals as the source of AI Convert Clock Timebase:

- AI Sample Clock Timebase
- 20 MHz Timebase

AI Convert Clock Timebase is not available as an output on the I/O connector.

AI Hold Complete Event Signal

The AI Hold Complete Event (`ai/HoldCompleteEvent`) signal generates a pulse after each A/D conversion begins. You can route AI Hold Complete Event out to any PFI <0..15> or RTSI <0..7> terminal.

The polarity of AI Hold Complete Event is software-selectable, but is typically configured so that a low-to-high leading edge can clock external AI multiplexers indicating when the input signal has been sampled and can be removed.

AI Start Trigger Signal

Use the AI Start Trigger (`ai/StartTrigger`) signal to begin a measurement acquisition. A measurement acquisition consists of one or more samples. If you do not use triggers, begin a measurement with a software command. Once the acquisition begins, configure the acquisition to stop:

- When a certain number of points are sampled (in finite mode)
- After a hardware reference trigger (in finite mode)
- With a software command (in continuous mode)

An acquisition that uses a start trigger (but not a reference trigger) is sometimes referred to as a posttriggered acquisition.

Using a Digital Source

To use AI Start Trigger with a digital source, specify a source and an edge. The source can be any of the following signals:

- PFI <0..15>
- RTSI <0..7>
- Counter *n* Internal Output
- PXI_STAR

The source also can be one of several other internal signals on your DAQ device. Refer to *Device Routing in MAX* in the *NI-DAQmx Help* or the *LabVIEW Help* for more information.

You also can specify whether the measurement acquisition begins on the rising edge or falling edge of AI Start Trigger.

Using an Analog Source

When you use an analog trigger source, the acquisition begins on the first rising edge of the Analog Comparison Event signal.

Routing AI Start Trigger to an Output Terminal

You can route AI Start Trigger out to any PFI <0..15> or RTSI <0..7> terminal. The output is an active high pulse. All PFI terminals are configured as inputs by default.

The device also uses AI Start Trigger to initiate pretriggered DAQ operations. In most pretriggered applications, a software trigger generates AI Start Trigger. Refer to the *AI Reference Trigger Signal* section for a complete description of the use of AI Start Trigger and AI Reference Trigger in a pretriggered DAQ operation.

AI Reference Trigger Signal

Use AI Reference Trigger (ai/ReferenceTrigger) signal to stop a measurement acquisition. To use a reference trigger, specify a buffer of finite size and a number of pretrigger samples (samples that occur before the reference trigger). The number of posttrigger samples (samples that occur after the reference trigger) desired is the buffer size minus the number of pretrigger samples.

Once the acquisition begins, the DAQ device writes samples to the buffer. After the DAQ device captures the specified number of pretrigger samples, the DAQ device begins to look for the reference trigger condition. If the reference trigger condition occurs before the DAQ device captures the specified number of pretrigger samples, the DAQ device ignores the condition.

If the buffer becomes full, the DAQ device continuously discards the oldest samples in the buffer to make space for the next sample. This data can be accessed (with some limitations) before the DAQ device discards it. Refer to the KnowledgeBase document, *Can a Pretriggered Acquisition be Continuous?*, for more information. To access this KnowledgeBase, go to ni.com/info and enter the Info Code `rdcanq`.

When the reference trigger occurs, the DAQ device continues to write samples to the buffer until the buffer contains the number of posttrigger samples desired. Figure 4-23 shows the final buffer.

Figure 4-23. Reference Trigger Final Buffer

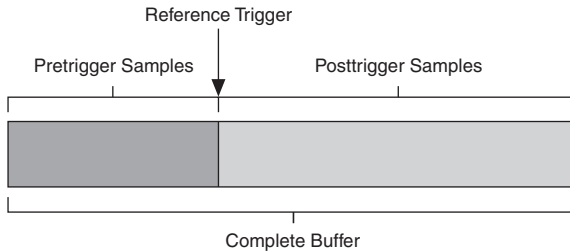

Using a Digital Source

To use AI Reference Trigger with a digital source, specify a source and an edge. The source can be any of the following signals:

- PFI <0..15>
- RTSI <0..7>
- PXI_STAR

The source also can be one of several internal signals on your DAQ device. Refer to *Device Routing in MAX* in the *NI-DAQmx Help* or the *LabVIEW Help* for more information.

You also can specify whether the measurement acquisition stops on the rising edge or falling edge of AI Reference Trigger.

Using an Analog Source

When you use an analog trigger source, the acquisition stops on the first rising edge of the Analog Comparison Event signal.

Routing AI Reference Trigger Signal to an Output Terminal

You can route AI Reference Trigger out to any PFI <0..15> or RTSI <0..7> terminal.

All PFI terminals are configured as inputs by default.

AI Pause Trigger Signal

Use the AI Pause Trigger (ai/PauseTrigger) signal to pause and resume a measurement acquisition. The internal sample clock pauses while the external trigger signal is active and resumes when the signal is inactive. You can program the active level of the pause trigger to be high or low.

Using a Digital Source

To use AI Pause Trigger, specify a source and a polarity. The source can be any of the following signals:

- PFI <0..15>
- RTSI <0..7>
- PXI_STAR

The source also can be one of several other internal signals on your DAQ device. Refer to *Device Routing in MAX* in the *NI-DAQmx Help* or the *LabVIEW Help* for more information.

Using an Analog Source

When you use an analog trigger source, the internal sample clock pauses when the Analog Comparison Event signal is low and resumes when the signal goes high (or vice versa).

Routing AI Pause Trigger Signal to an Output Terminal

You can route AI Pause Trigger out to RTSI <0..7>.



Note Pause triggers are only sensitive to the level of the source, not the edge.

Getting Started with AI Applications in Software

You can use the M Series device in the following analog input applications:

- Single-point analog input
- Finite analog input
- Continuous analog input

You can perform these applications through DMA, interrupt, or programmed I/O data transfer mechanisms. Some of the applications also use start, reference, and pause triggers.



Note For more information about programming analog input applications and triggers in software, refer to the *NI-DAQmx Help* or the *LabVIEW Help*.

Analog Output

Many M Series devices have analog output functionality. M Series devices that support analog output have either two or four AO channels that are controlled by a single clock and are capable of waveform generation. Refer to the specifications document for your device for information about the capabilities of your device.

Figure 5-1 shows the analog output circuitry of M Series devices.

Figure 5-1. M Series Analog Output Circuitry

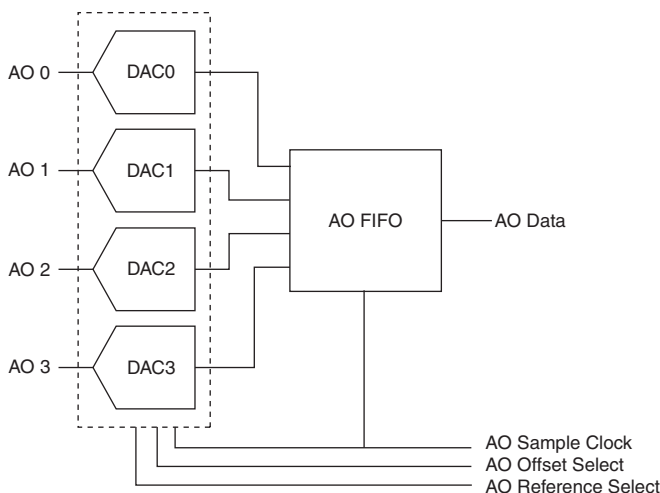

The main blocks featured in the M Series analog output circuitry are as follows:

- **DACs**—Digital-to-analog converters (DACs) convert digital codes to analog voltages.
- **AO FIFO**—The AO FIFO enables analog output waveform generation. It is a first-in-first-out (FIFO) memory buffer between the computer and the DACs. It allows you to download the points of a waveform to your M Series device without host computer interaction.
- **AO Sample Clock**—The AO Sample Clock signal reads a sample from the DAC FIFO and generates the AO voltage.
- **AO Offset and AO Reference Selection**—AO offset and AO reference selection signals allow you to change the range of the analog outputs.

AO Offset and AO Reference Selection

AO offset and AO reference selection allow you to set the AO range. The AO range describes the set of voltages the device can generate. The digital codes of the DAC are spread evenly across the AO range. So, if the range is smaller, the AO has better resolution; that is, the voltage output difference between two consecutive codes is smaller. Therefore, the AO is more accurate.

The AO range of a device is all of the voltages between:

(AO Offset - AO Reference) and (AO Offset + AO Reference)

The possible settings for AO reference depend on the device model. For models not described below, refer to the specifications for your device.

- **(NI 622x Devices)** On NI 622x devices, the AO offset is always 0 V (AO GND). The AO reference is always 10 V. So, for NI 622x devices, the AO range = ± 10 V.
- **(NI 625x Devices)** On NI 625x devices, the AO offset is always 0 V (AO GND). The AO reference of each analog output (AO <0..3>) can be individually set to one of the following:
 - ± 10 V
 - ± 5 V
 - $\pm \text{APFI } \langle 0,1 \rangle$

You can connect an external signal to APFI <0,1> to provide the AO reference. The AO reference can be a positive or negative voltage. If AO reference is a negative voltage, the polarity of the AO output is inverted. The valid ranges of APFI <0,1> are listed in the device specifications.

You can use one of the AO <0..3> signals to be the AO reference for a different AO signal. However, you must externally connect this channel to APFI 0 or APFI 1.

- **(NI 628x Devices)** On NI 628x devices, the AO offset of each analog output can be individually set to one of the following:
 - 0 V (AO GND)
 - 5 V
 - APFI <0,1>
 - AO <0..3>

You can connect an external signal to APFI <0,1> to provide the AO offset.

You can route the output of one of the AO <0..3> signals to be the AO offset for a different AO <0..3> signal. For example, AO 0 can be routed to be the AO offset of AO 1. This route is done on the device; no external connections are required.

You cannot route an AO channel to be its own offset.

On NI 628x devices, the AO reference of each analog output can be individually set to one of the following:

- ± 10 V
- ± 5 V
- $\pm \text{APFI} \langle 0,1 \rangle$
- $\pm \text{AO} \langle 0..3 \rangle$

You can connect an external signal to APFI $\langle 0,1 \rangle$ to provide the AO reference.

You can route the output of one of the AO $\langle 0..3 \rangle$ signals to be the AO reference for a different AO $\langle 0..3 \rangle$ signal. For example, AO 0 can be routed to be the AO reference of AO 1. This route is done on the device; no external connections are required.

You cannot route an AO channel to be its own reference.

The AO reference can be a positive or negative voltage. If AO reference is a negative voltage, the polarity of the AO output is inverted.



Note When using an external reference, the output signal is not calibrated in software. You can generate a value and measure the voltage offset to calibrate your output in software.

Minimizing Glitches on the Output Signal

When you use a DAC to generate a waveform, you may observe glitches on the output signal. These glitches are normal; when a DAC switches from one voltage to another, it produces glitches due to released charges. The largest glitches occur when the most significant bit of the DAC code changes. You can build a lowpass deglitching filter to remove some of these glitches, depending on the frequency and nature of the output signal. Visit ni.com/support for more information about minimizing glitches.

Analog Output Data Generation Methods

When performing an analog output operation, you either can perform software-timed or hardware-timed generations.

Software-Timed Generations

With a software-timed generation, software controls the rate at which data is generated. Software sends a separate command to the hardware to initiate each DAC conversion. In NI-DAQmx, software-timed generations are referred to as on-demand timing. Software-timed generations are also referred to as immediate or static operations. They are typically used for writing a single value out, such as a constant DC voltage.

Hardware-Timed Generations

With a hardware-timed generation, a digital hardware signal controls the rate of the generation. This signal can be generated internally on your device or provided externally.

Hardware-timed generations have several advantages over software-timed acquisitions:

- The time between samples can be much shorter.
- The timing between samples can be deterministic.
- Hardware-timed generations can use hardware triggering.

Hardware-timed operations can be buffered or non-buffered. A buffer is a temporary storage in computer memory for to-be-generated samples.

- **Buffered**—In a buffered acquisition, data is moved from a PC buffer to the DAQ device's onboard FIFO using DMA or interrupts for NI PCI/PCIe/PXI/PXIE devices or USB Signal Streams for USB devices before it is written to the DACs one sample at a time. Buffered acquisitions typically allow for much faster transfer rates than non-buffered acquisitions because data is moved in large blocks, rather than one point at a time.

One property of buffered I/O operations is the sample mode. The sample mode can be either finite or continuous:

- Finite sample mode generation refers to the generation of a specific, predetermined number of data samples. Once the specified number of samples has been written out, the generation stops.
- Continuous generation refers to the generation of an unspecified number of samples. Instead of generating a set number of data samples and stopping, a continuous generation continues until you stop the operation. There are several different methods of continuous generation that control what data is written. These methods are regeneration, FIFO regeneration and non-regeneration modes:
 - Regeneration is the repetition of the data that is already in the buffer. Standard regeneration is when data from the PC buffer is continually downloaded to the FIFO to be written out. New data can be written to the PC buffer at any time without disrupting the output.
 - With FIFO regeneration, the entire buffer is downloaded to the FIFO and regenerated from there. Once the data is downloaded, new data cannot be written to the FIFO. To use FIFO regeneration, the entire buffer must fit within the FIFO size. The advantage of using FIFO regeneration is that it does not require communication with the main host memory once the operation is started, thereby preventing any problems that may occur due to excessive bus traffic.
 - With non-regeneration, old data is not repeated. New data must be continually written to the buffer. If the program does not write new data to the buffer at a fast enough rate to keep up with the generation, the buffer underflows and causes an error.

- **Non-buffered**—In non-buffered acquisitions, data is written directly to the DACs on the device. Typically, hardware-timed, non-buffered operations are used to write single samples with good latency and known time increments between them.



Note (NI USB-62xx Devices) USB M Series devices do not support non-buffered hardware-timed operations.

Analog Output Triggering

Analog output supports two different triggering actions:

- Start trigger
- Pause trigger

An analog or digital trigger can initiate these actions. All M Series devices support digital triggering, but some do not support analog triggering. To find your device's triggering options, refer to the specifications document for your device. Refer to the [AO Start Trigger Signal](#) and [AO Pause Trigger Signal](#) sections for more information about these triggering actions.

Connecting Analog Output Signals

AO <0..3> are the voltage output signals for AO channels 0, 1, 2, and 3. AO GND is the ground reference for AO <0..3>.

Figure 5-2 shows how to make AO connections to the device.

Figure 5-2. Analog Output Connections

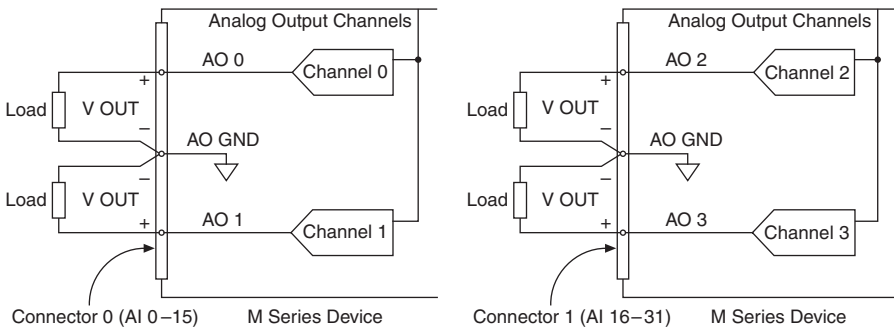

Analog Output Timing Signals

Figure 5-3 summarizes all of the timing options provided by the analog output timing engine.

Figure 5-3. Analog Output Timing Options

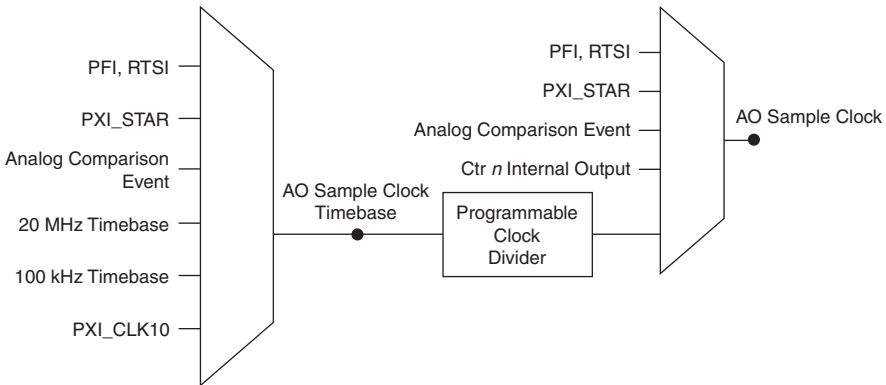

M Series devices feature the following AO (waveform generation) timing signals:

- *AO Start Trigger Signal*
- *AO Pause Trigger Signal*
- *AO Sample Clock Signal*
- *AO Sample Clock Timebase Signal*

AO Start Trigger Signal

Use the AO Start Trigger (`ao/StartTrigger`) signal to initiate a waveform generation. If you do not use triggers, you can begin a generation with a software command.

Using a Digital Source

To use AO Start Trigger, specify a source and an edge. The source can be one of the following signals:

- A pulse initiated by host software
- `PFI <0..15>`
- `RTSI <0..7>`
- AI Reference Trigger (`ai/ReferenceTrigger`)
- AI Start Trigger (`ai/StartTrigger`)
- `PXI_STAR`

The source also can be one of several internal signals on your DAQ device. Refer to *Device Routing in MAX* in the *NI-DAQmx Help* or the *LabVIEW Help* for more information.

You also can specify whether the waveform generation begins on the rising edge or falling edge of AO Start Trigger.

Using an Analog Source

When you use an analog trigger source, the waveform generation begins on the first rising edge of the Analog Comparison Event signal. Refer to the [Triggering with an Analog Source](#) section of Chapter 11, [Triggering](#), for more information.

Routing AO Start Trigger Signal to an Output Terminal

You can route AO Start Trigger out to any PFI <0..15> or RTSI <0..7> terminal.

The output is an active high pulse. PFI terminals are configured as inputs by default.

AO Pause Trigger Signal

Use the AO Pause Trigger (ao/PauseTrigger) signal to mask off samples in a DAQ sequence. That is, when AO Pause Trigger is active, no samples occur.

AO Pause Trigger does not stop a sample that is in progress. The pause does not take effect until the beginning of the next sample.

When you generate analog output signals, the generation pauses as soon as the pause trigger is asserted. If the source of your sample clock is the onboard clock, the generation resumes as soon as the pause trigger is deasserted, as shown in Figure 5-4.

Figure 5-4. AO Pause Trigger with the Onboard Clock Source

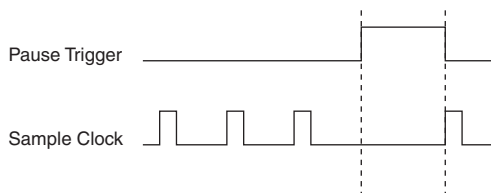

If you are using any signal other than the onboard clock as the source of your sample clock, the generation resumes as soon as the pause trigger is deasserted and another edge of the sample clock is received, as shown in Figure 5-5.

Figure 5-5. AO PauseTrigger with Other Signal Source

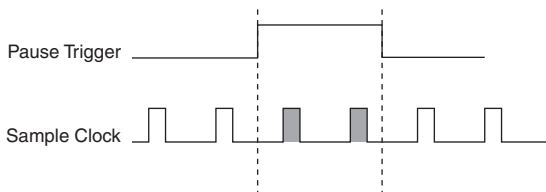

Using a Digital Source

To use AO Pause Trigger, specify a source and a polarity. The source can be one of the following signals:

- PFI <0..15>
- RTSI <0..7>
- PXI_STAR

The source also can be one of several other internal signals on your DAQ device. Refer to *Device Routing in MAX* in the *NI-DAQmx Help* or the *LabVIEW Help* for more information.

You also can specify whether the samples are paused when AO Pause Trigger is at a logic high or low level.

Using an Analog Source

When you use an analog trigger source, the samples are paused when the Analog Comparison Event signal is at a high level. Refer to the [Triggering with an Analog Source](#) section of Chapter 11, [Triggering](#), for more information.

Routing AO Pause Trigger Signal to an Output Terminal

You can route AO Pause Trigger out to RTSI <0..7>.

AO Sample Clock Signal

Use the AO Sample Clock (ao/SampleClock) signal to initiate AO samples. Each sample updates the outputs of all of the DACs. You can specify an internal or external source for AO Sample Clock. You also can specify whether the DAC update begins on the rising edge or falling edge of AO Sample Clock.

Using an Internal Source

One of the following internal signals can drive AO Sample Clock:

- AO Sample Clock Timebase (divided down)
- Counter *n* Internal Output

A programmable internal counter divides down the AO Sample Clock Timebase signal.

Using an External Source

Use one of the following external signals as the source of AO Sample Clock:

- PFI <0..15>
- RTSI <0..7>
- PXI_STAR
- Analog Comparison Event (an analog trigger)

Routing AO Sample Clock Signal to an Output Terminal

You can route AO Sample Clock (as an active low signal) out to any PFI <0..15> or RTSI <0..7> terminal.

Other Timing Requirements

A counter on your device internally generates AO Sample Clock unless you select some external source. AO Start Trigger starts the counter and either the software or hardware can stop it once a finite generation completes. When using an internally generated AO Sample Clock, you also can specify a configurable delay from AO Start Trigger to the first AO Sample Clock pulse. By default, this delay is two ticks of AO Sample Clock Timebase.

Figure 5-6 shows the relationship of AO Sample Clock to AO Start Trigger.

Figure 5-6. AO Sample Clock and AO Start Trigger

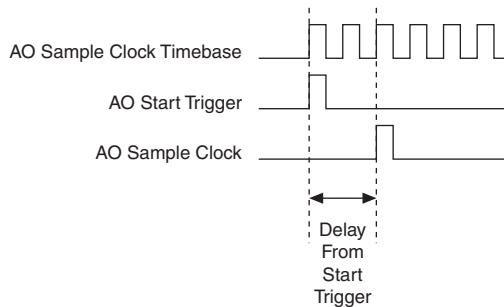

AO Sample Clock Timebase Signal

The AO Sample Clock Timebase (ao/SampleClockTimebase) signal is divided down to provide a source for AO Sample Clock.

You can route any of the following signals to be the AO Sample Clock Timebase signal:

- 20 MHz Timebase
- 100 kHz Timebase
- PXI_CLK10
- PFI <0..15>
- RTSI <0..7>
- PXI_STAR
- Analog Comparison Event (an analog trigger)

AO Sample Clock Timebase is not available as an output on the I/O connector.

You might use AO Sample Clock Timebase if you want to use an external sample clock signal, but need to divide the signal down. If you want to use an external sample clock signal, but do not need to divide the signal, then you should use AO Sample Clock rather than AO Sample Clock Timebase.

Getting Started with AO Applications in Software

You can use an M Series device in the following analog output applications:

- Single-point (on-demand) generation
- Finite generation
- Continuous generation
- Waveform generation

You can perform these generations through programmed I/O, interrupt, or DMA data transfer mechanisms. Some of the applications also use start triggers and pause triggers.



Note For more information about programming analog output applications and triggers in software, refer to the *NI-DAQmx Help* or the *LabVIEW Help*.

Digital I/O

M Series devices contain up to 32 lines of bidirectional DIO signals on Port 0. In addition, M Series devices have up to 16 PFI signals that can function as static DIO signals.

M Series devices support the following DIO features on Port 0:

- Up to 32 lines of DIO
- Direction and function of each terminal individually controllable
- Static digital input and output
- High-speed digital waveform generation
- High-speed digital waveform acquisition
- DI change detection trigger/interrupt

Figure 6-1 shows the circuitry of one DIO line. Each DIO line is similar. The following sections provide information about the various parts of the DIO circuit.

Figure 6-1. M Series Digital I/O Circuitry

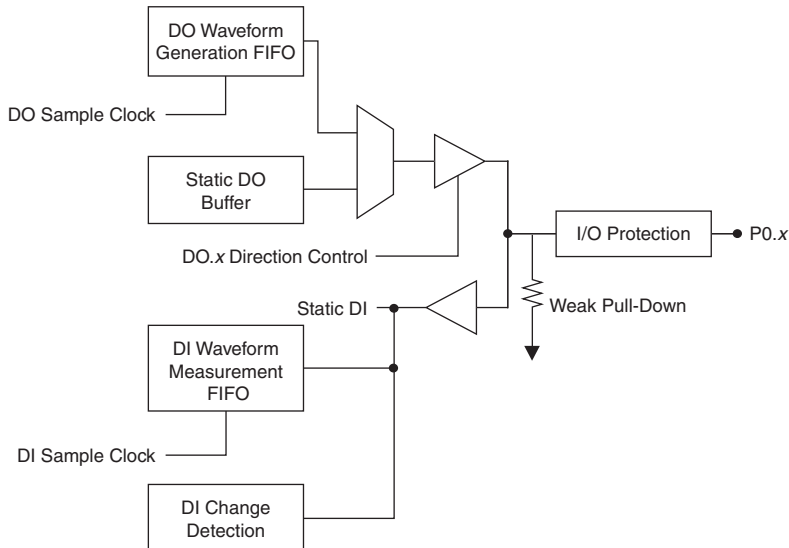

The DIO terminals are named P0.<0..31> on the M Series device I/O connector.

The voltage input and output levels and the current drive levels of the DIO lines are listed in the specifications of your device.

Static DIO

Each of the M Series DIO lines can be used as a static DI or DO line. You can use static DIO lines to monitor or control digital signals. Each DIO can be individually configured as a digital input (DI) or digital output (DO).

All samples of static DI lines and updates of DO lines are software-timed.

P0.6 and P0.7 on 68-pin M Series devices also can control the up/down input of general-purpose counters 0 and 1, respectively. However, it is recommended that you use PFI signals to control the up/down input of the counters. The up/down control signals, Counter 0 Up_Down and Counter 1 Up_Down, are input-only and do not affect the operation of the DIO lines.

Digital Waveform Triggering

M Series devices do not have an independent DI or DO Start Trigger for digital waveform acquisition or generation. To trigger a DI or DO operation, first select a signal to be the source of DI Sample Clock or DO Sample Clock. Then, generate a trigger that initiates pulses on the source signal. The method for generating this trigger depends on which signal is the source of DI Sample Clock or DO Sample Clock.

For example, consider the case where you are using AI Sample Clock as the source of DI Sample Clock. To initiate pulses on AI Sample Clock (and therefore on DI Sample Clock), you use AI Start Trigger to trigger the start of an AI operation. The AI Start Trigger causes the M Series device to begin generating AI Sample clock pulses, which in turn generates DI Sample clock pulses, as shown in Figure 6-2.

Figure 6-2. Digital Waveform Triggering

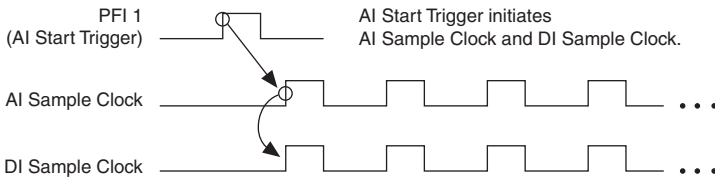

Similarly, if you are using AO Sample Clock as the source of DI Sample Clock, then AO Start Trigger initiates both AO and DI operations.

If you are using a Counter output as the source of DI Sample Clock, the counter's start trigger, enables the counter which drives DI Sample Clock.

If you are using an external signal (such as PFI x) as the source for DI Sample Clock or DO Sample Clock, you must trigger that external signal.

Digital Waveform Acquisition

You can acquire digital waveforms on the Port 0 DIO lines. The DI waveform acquisition FIFO stores the digital samples. M Series devices have a DMA controller dedicated to moving data from the DI waveform acquisition FIFO to system memory. The DAQ device samples the DIO lines on each rising or falling edge of a clock signal, DI Sample Clock.

You can configure each DIO line to be an output, a static input, or a digital waveform acquisition input.

M Series devices feature the *DI Sample Clock Signal* digital input timing signal.

DI Sample Clock Signal

Use the DI Sample Clock (di/SampleClock) signal to sample the P0.<0..31> terminals and store the result in the DI waveform acquisition FIFO. M Series devices do not have the ability to divide down a timebase to produce an internal DI Sample Clock for digital waveform acquisition. Therefore, you must route an external signal or one of many internal signals from another subsystem to be the DI Sample Clock. For example, you can correlate digital and analog samples in time by sharing your AI Sample Clock or AO Sample Clock as the source of your DI Sample Clock. To sample a digital signal independent of an AI, AO, or DO operation, you can configure a counter to generate the desired DI Sample Clock or use an external signal as the source of the clock.

If the DAQ device receives a DI Sample Clock when the FIFO is full, it reports an overflow error to the host software.

Using an Internal Source

To use DI Sample Clock with an internal source, specify the signal source and the polarity of the signal. The source can be any of the following signals:

- AI Sample Clock (ai/SampleClock)
- AI Convert Clock (ai/ConvertClock)
- AO Sample Clock (ao/SampleClock)
- Counter *n* Internal Output
- Frequency Output
- DI Change Detection Output

Several other internal signals can be routed to DI Sample Clock through RTSI. Refer to *Device Routing in MAX* in the *NI-DAQmx Help* or the *LabVIEW Help* for more information.

Using an External Source

You can route any of the following signals as DI Sample Clock:

- PFI <0..15>
- RTSI <0..7>
- PXI_STAR
- Analog Comparison Event (an analog trigger)

You can sample data on the rising or falling edge of DI Sample Clock.

Routing DI Sample Clock to an Output Terminal

You can route DI Sample Clock out to any PFI terminal. The PFI circuitry inverts the polarity of DI Sample Clock before driving the PFI terminal.

Digital Waveform Generation

You can generate digital waveforms on the Port 0 DIO lines. The DO waveform generation FIFO stores the digital samples. M Series devices have a DMA controller dedicated to moving data from the system memory to the DO waveform generation FIFO. The DAQ device moves samples from the FIFO to the DIO terminals on each rising or falling edge of a clock signal, DO Sample Clock. You can configure each DIO signal to be an input, a static output, or a digital waveform generation output.

The FIFO supports a retransmit mode. In the retransmit mode, after all the samples in the FIFO have been clocked out, the FIFO begins outputting all of the samples again in the same order. For example, if the FIFO contains five samples, the pattern generated consists of sample #1, #2, #3, #4, #5, #1, #2, #3, #4, #5, #1, and so on.

M Series devices feature the *DO Sample Clock Signal* digital output timing signal.

DO Sample Clock Signal

Use the DO Sample Clock (do/SampleClock) signal to update the DO terminals with the next sample from the DO waveform generation FIFO. M Series devices do not have the ability to divide down a timebase to produce an internal DO Sample Clock for digital waveform generation. Therefore, you must route an external signal or one of many internal signals from another subsystem to be the DO Sample Clock. For example, you can correlate digital and analog samples in time by sharing your AI Sample Clock or AO Sample Clock as the source of your DO Sample Clock. To generate digital data independent of an AI, AO, or DI operation, you can configure a counter to generate the desired DO Sample Clock or use an external signal as the source of the clock.

If the DAQ device receives a DO Sample Clock when the FIFO is empty, the DAQ device reports an underflow error to the host software.

Using an Internal Source

To use DO Sample Clock with an internal source, specify the signal source and the polarity of the signal. The source can be any of the following signals:

- AI Sample Clock (ai/SampleClock)
- AI Convert Clock (ai/ConvertClock)
- AO Sample Clock (ao/SampleClock)
- Counter n Internal Output
- Frequency Output
- DI Change Detection Output

Several other internal signals can be routed to DO Sample Clock through RTSI. Refer to *Device Routing in MAX* in the *NI-DAQmx Help* or the *LabVIEW Help* for more information.

Using an External Source

You can route any of the following signals as DO Sample Clock:

- PFI <0..15>
- RTSI <0..7>
- PXI_STAR
- Analog Comparison Event (an analog trigger)

You can generate samples on the rising or falling edge of DO Sample Clock.

You must ensure that the time between two active edges of DO Sample Clock is not too short. If the time is too short, the DO waveform generation FIFO is not able to read the next sample fast enough. The DAQ device reports an overrun error to the host software.

Routing DO Sample Clock to an Output Terminal

You can route DO Sample Clock out to any PFI terminal. The PFI circuitry inverts the polarity of DO Sample Clock before driving the PFI terminal.

I/O Protection

Each DIO and PFI signal is protected against overvoltage, undervoltage, and overcurrent conditions as well as ESD events. However, you should avoid these fault conditions by following these guidelines:

- If you configure a PFI or DIO line as an output, do not connect it to any external signal source, ground, or power supply.
- If you configure a PFI or DIO line as an output, understand the current requirements of the load connected to these signals. Do not exceed the specified current output limits of the DAQ device. NI has several signal conditioning solutions for digital applications requiring high current drive.

- If you configure a PFI or DIO line as an input, do not drive the line with voltages outside of its normal operating range. The PFI or DIO lines have a smaller operating range than the AI signals.
- Treat the DAQ device as you would treat any static sensitive device. Always properly ground yourself and the equipment when handling the DAQ device or connecting to it.

Programmable Power-Up States

At system startup and reset, the hardware sets all PFI and DIO lines to high-impedance inputs by default. The DAQ device does not drive the signal high or low. Each line has a weak pull-down resistor connected to it, as described in the specifications document for your device.

NI-DAQmx supports programmable power-up states for PFI and DIO lines. Software can program any value at power up to the P0, P1, or P2 lines. The PFI and DIO lines can be set as:

- A high-impedance input with a weak pull-down resistor (default)
- An output driving a 0
- An output driving a 1

Refer to the *NI-DAQmx Help* or the *LabVIEW Help* for more information about setting power-up states in NI-DAQmx or MAX.



Note When using your M Series device to control an SCXI chassis, DIO lines 0, 1, 2, and 4 are used as communication lines and must be left to power-up in the default high-impedance state to avoid potential damage to these signals.

DI Change Detection

You can configure the DAQ device to detect changes in the DIO signals. Figure 6-3 shows a block diagram of the DIO change detection circuitry.

Figure 6-3. DI Change Detection

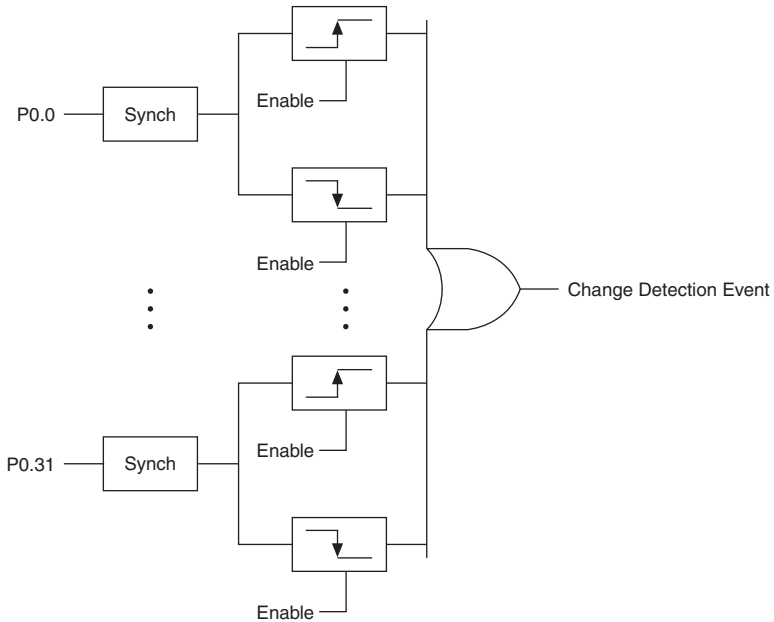

Note DI change detection is supported in NI-DAQmx 8.0 and later.

You can enable the DIO change detection circuitry to detect rising edges, falling edges, or either edge individually on each DIO line. The DAQ devices synchronize each DI signal to 80MHzTimebase, and then sends the signal to the change detectors. The circuitry ORs the output of all enabled change detectors from every DI signal. The result of this OR is the Change Detection Event signal.

The Change Detection Event signal can do the following:

- Drive any RTSI <0..7>, PFI <0..15>, or PXI_STAR signal
- Drive the DO Sample Clock or DI Sample Clock
- Generate an interrupt

The Change Detection Event signal also can be used to detect changes on digital output events.

DI Change Detection Applications

The DIO change detection circuitry can interrupt a user program when one of several DIO signals changes state.

You also can use the output of the DIO change detection circuitry to trigger a DI or counter acquisition on the logical OR of several digital signals. To trigger on a single digital signal, refer to the *Triggering with a Digital Source* section of Chapter 11, *Triggering*. By routing the Change Detection Event signal to a counter, you also can capture the relative time between samples.

You also can use the Change Detection Event signal to trigger DO or counter generations.

Connecting Digital I/O Signals

The DIO signals, P0.<0..31>, P1.<0..7>, and P2.<0..7> are referenced to D GND. You can individually program each line as an input or output. Figure 6-4 shows P1.<0..3> configured for digital input and P1.<4..7> configured for digital output. Digital input applications include receiving TTL signals and sensing external device states, such as the state of the switch shown in the figure. Digital output applications include sending TTL signals and driving external devices, such as the LED shown in the figure.

Figure 6-4. Digital I/O Connections

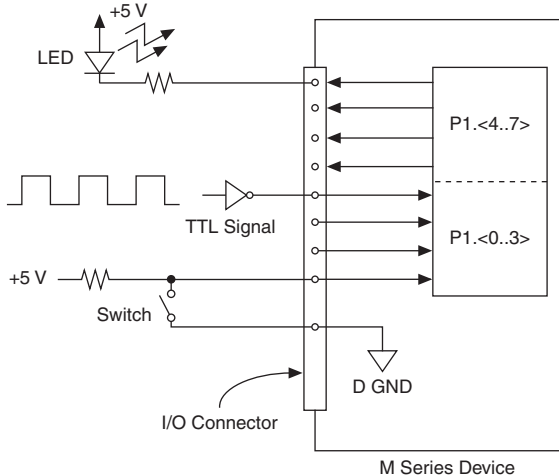

Caution Exceeding the maximum input voltage ratings, which are listed in the specifications document for each M Series device, can damage the DAQ device and the computer. NI is *not* liable for any damage resulting from such signal connections.

Getting Started with DIO Applications in Software

You can use the M Series device in the following digital I/O applications:

- Static digital input
- Static digital output
- Digital waveform generation
- Digital waveform acquisition
- DI change detection



Note For more information about programming digital I/O applications and triggers in software, refer to the *NI-DAQmx Help* or the *LabVIEW Help*.

Counters

M Series devices have two general-purpose 32-bit counter/timers and one frequency generator, as shown in Figure 7-1. The general-purpose counter/timers can be used for many measurement and pulse generation applications.

Figure 7-1. M Series Counter0 and Frequency Generator

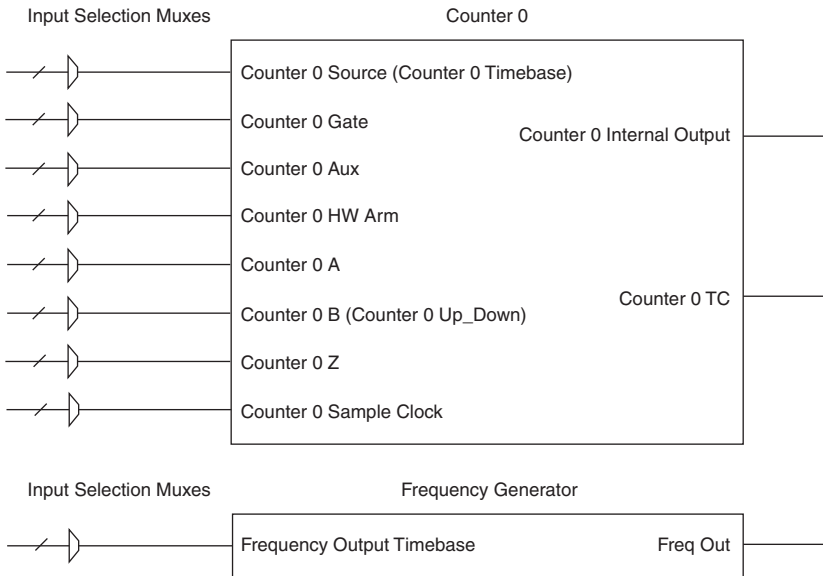

The counters have seven input signals, although in most applications only a few inputs are used.

For information about connecting counter signals, refer to the [Default Counter/Timer Pinouts](#) section.

Counter Input Applications

The following sections list the various counter input applications available on M Series devices:

- [Counting Edges](#)
- [Pulse-Width Measurement](#)
- [Period Measurement](#)
- [Semi-Period Measurement](#)

- [Frequency Measurement](#)
- [Position Measurement](#)
- [Two-Signal Edge-Separation Measurement](#)

Counting Edges

In edge counting applications, the counter counts edges on its Source after the counter is armed. You can configure the counter to count rising or falling edges on its Source input. You also can control the direction of counting (up or down) as described in the [Controlling the Direction of Counting](#) section.

Use the following edge counting options to read the counter values on your M Series device:

- [Single Point \(On-Demand\) Edge Counting](#)
- [Buffered \(Sample Clock\) Edge Counting](#)

Single Point (On-Demand) Edge Counting

With single point (on-demand) edge counting, the counter counts the number of edges on the Source input after the counter is armed. On-demand refers to the fact that software can read the counter contents at any time without disturbing the counting process. Figure 7-2 shows an example of single point edge counting.

Figure 7-2. Single Point (On-Demand) Edge Counting

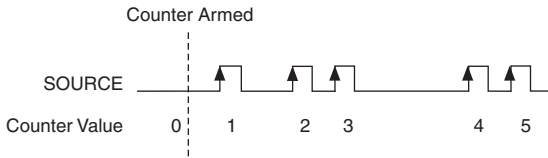

You also can use a pause trigger to pause (or gate) the counter. When the pause trigger is active, the counter ignores edges on its Source input. When the pause trigger is inactive, the counter counts edges normally.

You can route the pause trigger to the Gate input of the counter. You can configure the counter to pause counting when the pause trigger is high or when it is low. Figure 7-3 shows an example of on-demand edge counting with a pause trigger.

Figure 7-3. Single Point (On-Demand) Edge Counting with Pause Trigger

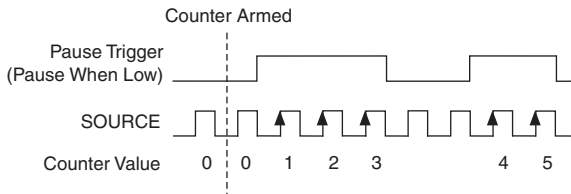

Buffered (Sample Clock) Edge Counting

With buffered edge counting (edge counting using a sample clock), the counter counts the number of edges on the Source input after the counter is armed. The value of the counter is sampled on each active edge of a sample clock. A DMA controller transfers the sampled values to host memory.

The count values returned are the cumulative counts since the counter armed event. That is, the sample clock does not reset the counter.

You can route the counter sample clock to the Gate input of the counter. You can configure the counter to sample on the rising or falling edge of the sample clock.

Figure 7-4 shows an example of buffered edge counting. Notice that counting begins when the counter is armed, which occurs before the first active edge on Gate.

Figure 7-4. Buffered (Sample Clock) Edge Counting

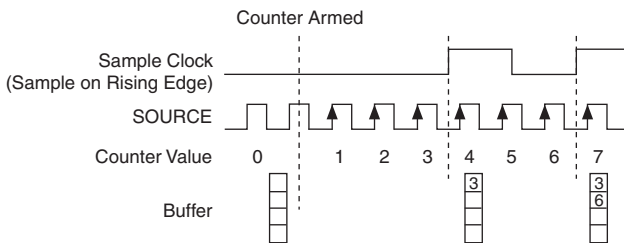

Controlling the Direction of Counting

In edge counting applications, the counter can count up or down. You can configure the counter to do the following:

- Always count up
- Always count down
- Count up when the Counter n B input is high; count down when it is low

For information about connecting counter signals, refer to the [Default Counter/Timer Pinouts](#) section.

Pulse-Width Measurement

In pulse-width measurements, the counter measures the width of a pulse on its Gate input signal. You can configure the counter to measure the width of high pulses or low pulses on the Gate signal.

You can route an internal or external periodic clock signal (with a known period) to the Source input of the counter. The counter counts the number of rising (or falling) edges on the Source signal while the pulse on the Gate signal is active.

You can calculate the pulse width by multiplying the period of the Source signal by the number of edges returned by the counter.

A pulse-width measurement will be accurate even if the counter is armed while a pulse train is in progress. If a counter is armed while the pulse is in the active state, it will wait for the next transition to the active state to begin the measurement.

Refer to the following sections for more information about M Series pulse-width measurement options:

- [Single Pulse-Width Measurement](#)
- [Buffered Pulse-Width Measurement](#)

Single Pulse-Width Measurement

With single pulse-width measurement, the counter counts the number of edges on the Source input while the Gate input remains active. When the Gate input goes inactive, the counter stores the count in a hardware save register and ignores other edges on the Gate and Source inputs. Software then reads the stored count.

Figure 7-5 shows an example of a single pulse-width measurement.

Figure 7-5. Single Pulse-Width Measurement

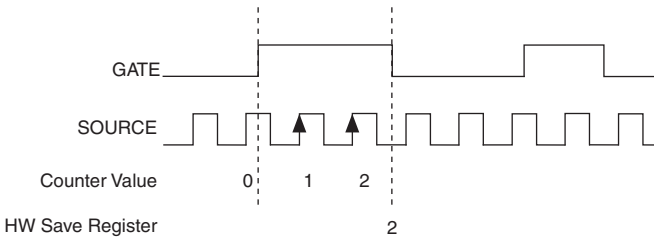

Buffered Pulse-Width Measurement

Buffered pulse-width measurement is similar to single pulse-width measurement, but buffered pulse-width measurement takes measurements over multiple pulses.

The counter counts the number of edges on the Source input while the Gate input remains active. On each trailing edge of the Gate signal, the counter stores the count in a hardware save register. A DMA controller transfers the stored values to host memory.

Figure 7-6 shows an example of a buffered pulse-width measurement.

Figure 7-6. Buffered Pulse-Width Measurement

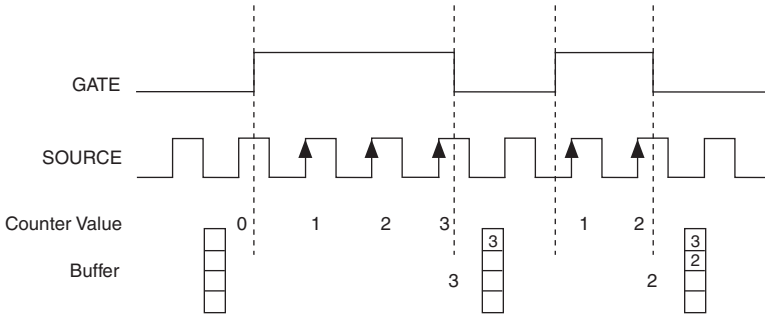

Note that if you are using an external signal as the Source, at least one Source pulse should occur between each active edge of the Gate signal. This condition ensures that correct values are returned by the counter. If this condition is not met, consider using duplicate count prevention, described in the [Duplicate Count Prevention](#) section.

For information about connecting counter signals, refer to the [Default Counter/Timer Pinouts](#) section.

Period Measurement

In period measurements, the counter measures a period on its Gate input signal after the counter is armed. You can configure the counter to measure the period between two rising edges or two falling edges of the Gate input signal.

You can route an internal or external periodic clock signal (with a known period) to the Source input of the counter. The counter counts the number of rising (or falling) edges occurring on the Source input between the two active edges of the Gate signal.

You can calculate the period of the Gate input by multiplying the period of the Source signal by the number of edges returned by the counter.

Refer to the following sections for more information about M Series period measurement options:

- [Single Period Measurement](#)
- [Buffered Period Measurement](#)

Single Period Measurement

With single period measurement, the counter counts the number of rising (or falling) edges on the Source input occurring between two active edges of the Gate input. On the second active edge of the Gate input, the counter stores the count in a hardware save register and ignores other edges on the Gate and Source inputs. Software then reads the stored count.

Figure 7-7 shows an example of a single period measurement.

Figure 7-7. Single Period Measurement

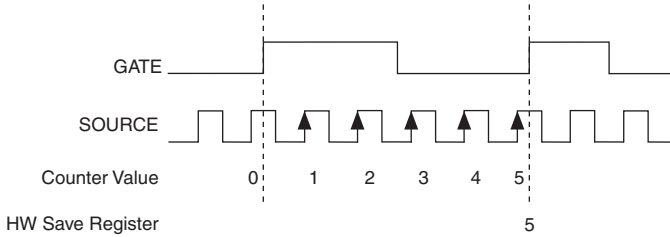

Buffered Period Measurement

Buffered period measurement is similar to single period measurement, but buffered period measurement measures multiple periods.

The counter counts the number of rising (or falling) edges on the Source input between each pair of active edges on the Gate input. At the end of each period on the Gate signal, the counter stores the count in a hardware save register. A DMA controller transfers the stored values to host memory.

The counter begins when it is armed. The arm usually occurs in the middle of a period of the Gate input. So the first value stored in the hardware save register does not reflect a full period of the Gate input. In most applications, this first point should be discarded.

Figure 7-8 shows an example of a buffered period measurement.

Figure 7-8. Buffered Period Measurement

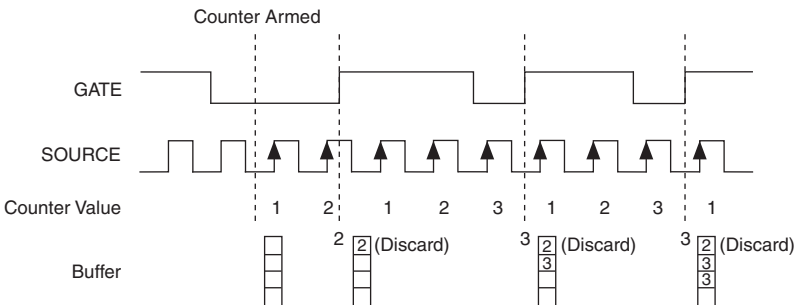

Note that if you are using an external signal as the Source, at least one Source pulse should occur between each active edge of the Gate signal. This condition ensures that correct values are returned by the counter. If this condition is not met, consider using duplicate count prevention, described in the [Duplicate Count Prevention](#) section.

For information about connecting counter signals, refer to the [Default Counter/Timer Pinouts](#) section.

Semi-Period Measurement

In semi-period measurements, the counter measures a semi-period on its Gate input signal after the counter is armed. A semi-period is the time between any two consecutive edges on the Gate input.

You can route an internal or external periodic clock signal (with a known period) to the Source input of the counter. The counter counts the number of rising (or falling) edges occurring on the Source input between two edges of the Gate signal.

You can calculate the semi-period of the Gate input by multiplying the period of the Source signal by the number of edges returned by the counter.

Refer to the following sections for more information about M Series semi-period measurement options:

- [Single Semi-Period Measurement](#)
- [Buffered Semi-Period Measurement](#)

Single Semi-Period Measurement

Single semi-period measurement is equivalent to single pulse-width measurement.

Buffered Semi-Period Measurement

In buffered semi-period measurement, on each edge of the Gate signal, the counter stores the count in a hardware save register. A DMA controller transfers the stored values to host memory.

The counter begins counting when it is armed. The arm usually occurs between edges on the Gate input. So the first value stored in the hardware save register does not reflect a full semi-period of the Gate input. In most applications, this first point should be discarded.

Figure 7-9 shows an example of a buffered semi-period measurement.

Figure 7-9. Buffered Semi-Period Measurement

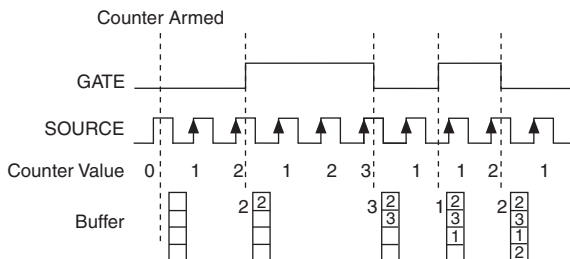

Note that if you are using an external signal as the Source, at least one Source pulse should occur between each active edge of the Gate signal. This condition ensures that correct values are returned by the counter. If this condition is not met, consider using duplicate count prevention, described in the *Duplicate Count Prevention* section.

For information about connecting counter signals, refer to the *Default Counter/Timer Pinouts* section.

Frequency Measurement

You can use the counters to measure frequency in several different ways. You can choose one of the following methods depending on your application:

- *Low Frequency with One Counter*
- *Low Frequency with One Counter (Averaged)*
- *High Frequency with Two Counters*
- *Large Range of Frequencies with Two Counters*

Refer to the *Choosing a Method for Measuring Frequency* section for a detailed comparison of these frequency measurement methods.

Low Frequency with One Counter

In this method, you measure one period of your signal using a known timebase. This method is good for low frequency signals.

You can route the signal to measure (F1) to the Gate of a counter. You can route a known timebase (Ft) to the Source of the counter. The known timebase can be 80MHzTimebase. For signals that might be slower than 0.02 Hz, use a slower known timebase.

You can configure the counter to measure one period of the gate signal. The frequency of F1 is the inverse of the period. Figure 7-10 illustrates this method.

Figure 7-10. Low Frequency with One Counter

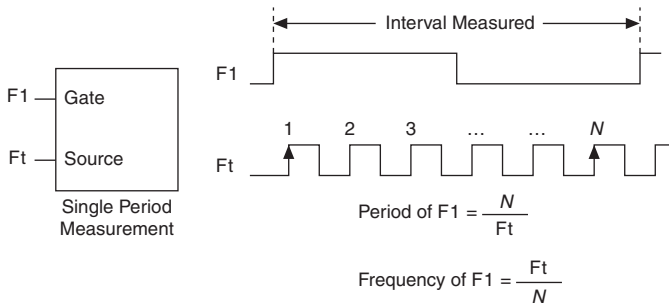

Low Frequency with One Counter (Averaged)

In this method, you measure several periods of your signal using a known timebase. This method is good for low to medium frequency signals.

You can route the signal to measure (F1) to the Gate of a counter. You can route a known timebase (Ft) to the Source of the counter. The known timebase can be 80MHzTimebase. For signals that might be slower than 0.02 Hz, use a slower known timebase.

You can configure the counter to make $N + 1$ buffered period measurements. Recall that the first period measurement in the buffer should be discarded.

Average the remaining K period measurements to determine the average period of F1. The frequency of F1 is the inverse of the average period. Figure 7-11 illustrates this method.

Figure 7-11. Low Frequency with One Counter (Averaged)

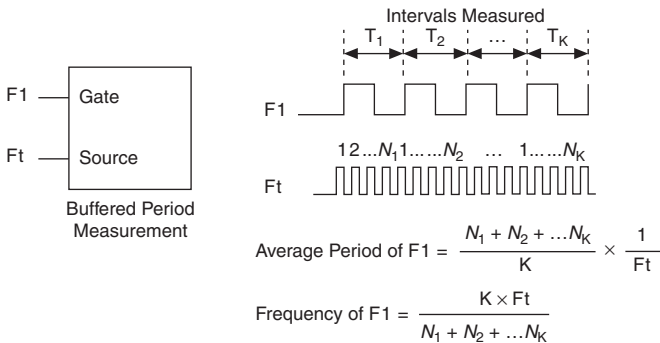

High Frequency with Two Counters

In this method, you measure one pulse of a known width using your signal and derive the frequency of your signal from the result. This method is good for high frequency signals.

In this method, you route a pulse of known duration (T) to the Gate of a counter. You can generate the pulse using a second counter. You also can generate the pulse externally and connect it to a PFI or RTSI terminal. You only need to use one counter if you generate the pulse externally.

Route the signal to measure (F1) to the Source of the counter. Configure the counter for a single pulse-width measurement. If you measure the width of pulse T to be N periods of F1, the frequency of F1 is N/T .

Figure 7-12 illustrates this method. Another option is to measure the width of a known pulse instead of a known pulse.

Figure 7-12. High Frequency with Two Counters

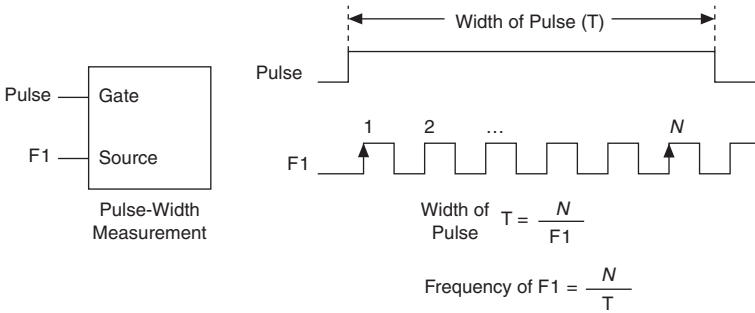

Large Range of Frequencies with Two Counters

By using two counters, you can accurately measure a signal that might be high or low frequency. This technique is called reciprocal frequency measurement. In this method, you generate a long pulse using the signal to measure. You then measure the long pulse with a known timebase. The M Series device can measure this long pulse more accurately than the faster input signal.

You can route the signal to measure to the Source input of Counter 0, as shown in Figure 7-13. Assume this signal to measure has frequency F1. Configure Counter 0 to generate a single pulse that is the width of N periods of the source input signal.

Figure 7-13. Large Range of Frequencies with Two Counters

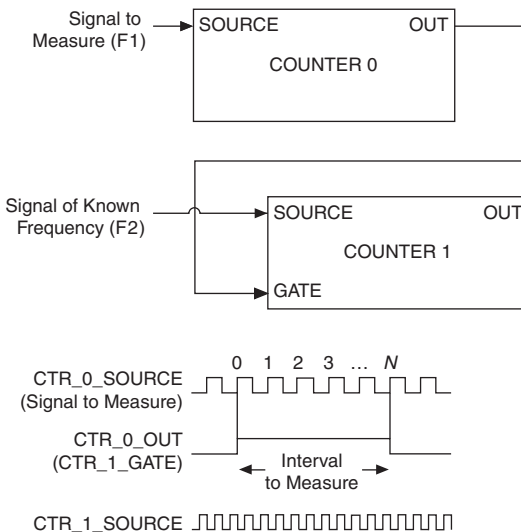

Then, route the Counter 0 Internal Output signal to the Gate input of Counter 1. You can route a signal of known frequency (F_2) to the Counter 1 Source input. F_2 can be 80MHzTimebase. For signals that might be slower than 0.02 Hz, use a slower known timebase. Configure Counter 1 to perform a single pulse-width measurement. Suppose the result is that the pulse width is J periods of the F_2 clock.

From Counter 0, the length of the pulse is N/F_1 . From Counter 1, the length of the same pulse is J/F_2 . Therefore, the frequency of F_1 is given by $F_1 = F_2 * (N/J)$.

Choosing a Method for Measuring Frequency

The best method to measure frequency depends on several factors including the expected frequency of the signal to measure, the desired accuracy, how many counters are available, and how long the measurement can take. For all frequency measurement methods, assume the following:

f_x	is the frequency to be measured if no error
f_k	is the known source or gate frequency
Measurement time (T)	is the time it takes to measure a single sample
Divide down (N)	is the integer to divide down measured frequency, only used in large range two counters

Here is how these variables apply to each method, summarized in Table 7-1.

- **One counter**—With one counter measurements, a known timebase is used for the source frequency (f_k). The measurement time is the period of the frequency to be measured, or $1/f_x$.
- **One counter averaged**—Measuring N periods of F_1 improves the accuracy of the measurement.
- **Two counters high frequency**—With the two counter high frequency method, the second counter provides a known measurement time. The gate frequency equals $1/\text{measurement time}$.
- **Two counters large range**—The two counter larger range measurement is the same as a one counter measurement, but now the user has an integer divide down of the signal. An internal timebase is still used for the source frequency (f_k), but the divide down means that the measurement time is the period of the divided down signal, or N/f_x where N is the divide down.

Table 7-1. Frequency Measurement Methods

Variable	One Counter		Two Counters	
	—	Averaged	High Frequency	Large Range
fk	Known timebase	Known timebase	$\frac{1}{\text{gating period}}$	Known timebase
T	$\frac{1}{fx}$	$\frac{N + 1}{fx}$	gating period	$\frac{N}{fx}$
Maximum frequency error (Hz)	$fx \times \frac{fx}{fk - fx}$	$fx \times \frac{fx}{N \times fk - fx}$	fk	$fx \times \frac{fx}{N \times fk - fx}$
Maximum error (%)	$\frac{fx}{fk - fx}$	$\frac{fx}{N \times fk - fx}$	$\frac{fk}{fx}$	$\frac{fx}{N \times fk - fx}$

Note: Accuracy equations do not take clock stability into account. Refer to your device specifications for clock stability.

Which Method Is Best?

This depends on the frequency to be measured, the rate at which you want to monitor the frequency and the accuracy you desire. Take for example, measuring a 50 kHz signal. Assuming that the measurement times for all measurements are configured the same, Table 7-2 summarizes the results.

Table 7-2. 50 kHz Frequency Measurement Methods

Variable	One Counter		Two Counters	
	—	Averaged	High Frequency	Large Range
fx	50,000	50,000	50,000	50,000
fk	100 M	100 M	1,000	100 M
Measurement time (mS)	0.02	1.02	1	1
N	—	50	—	50

Table 7-2. 50 kHz Frequency Measurement Methods (Continued)

Variable	One Counter		Two Counters	
	—	Averaged	High Frequency	Large Range
Maximum frequency error (Hz)	25	0.5	1,000	0.5
Maximum error (%)	0.05	0.001	2	0.001

From these results, you can see that while the measurement time for one counter is shorter, the accuracy is best in the sample clocked and two counter large range measurements. For another example, Table 7-3 shows the results for 5 MHz.

Table 7-3. 5 MHz Frequency Measurement Methods

Variable	One Counter		Two Counters	
	—	Averaged	High Frequency	Large Range
f_x	5 M	5 M	5 M	5 M
f_k	100 M	100 M	1,000	100 M
Measurement time (mS)	0.0002	1.0002	1	1
N	—	5,000	—	5,000
Maximum frequency error (Hz)	263 k	50	1,000	50
Maximum error (%)	5.26	0.001	0.02	0.001

- Using one counter for low frequency measurements is a good method for many applications. However, the accuracy of the measurement decreases as the frequency increases.
- Measuring with one counter (averaged) measures high and low frequency signals accurately. The advantage of this method is that it requires only one counter. Disadvantages include the possibility of FIFO overflow at high frequencies and high N for this method. These measurements take more time and consume some of the available PCI or PXI

bandwidth; if such bandwidth is not available due to other measurements taking place, this method may fail to transfer all the required samples to perform the measurement.

- Using two counters for high frequency measurements is accurate for high frequency signals. However, the accuracy decreases as the frequency of the signal to measure decreases. At very low frequencies, this method may be too inaccurate for your application. Another disadvantage of this method is that it requires two counters (if you cannot provide an external signal of known width). An advantage of high frequency measurements with two counters is that the measurement completes in a known amount of time.
- Measuring a large range of frequencies with two counters measures high and low frequency signals accurately. However, it requires two counters, and it has a variable sample time and variable error percent dependent on the input signal.

Table 7-4 summarizes some of the differences in methods of measuring frequency.

Table 7-4. Frequency Measurement Method Comparison

Comparison	One Counter		Two Counters	
	—	Averaged	High Frequency	Large Range
Number of counters used	1	1	1 or 2	2
Number of measurements returned	1	Many	1	1
Measures high frequency signals accurately	Poor	Fair	Good	Good
Measures low frequency signals accurately	Good	Good	Poor	Good

For information about connecting counter signals, refer to the [Default Counter/Timer Pinouts](#) section.

Position Measurement

You can use the counters to perform position measurements with quadrature encoders or two-pulse encoders. You can measure angular position with X1, X2, and X4 angular encoders. Linear position can be measured with two-pulse encoders. You can choose to do either a single point (on-demand) position measurement or a buffered (sample clock) position measurement. You must arm a counter to begin position measurements.

Refer to the following sections for more information about the M Series position measurement options:

- [Measurements Using Quadrature Encoders](#)
- [Measurements Using Two Pulse Encoders](#)
- [Buffered \(Sample Clock\) Position Measurement](#)

Measurements Using Quadrature Encoders

The counters can perform measurements of quadrature encoders that use X1, X2, or X4 encoding. A quadrature encoder can have up to three channels—channels A, B, and Z.

- **X1 Encoding**—When channel A leads channel B in a quadrature cycle, the counter increments. When channel B leads channel A in a quadrature cycle, the counter decrements. The amount of increments and decrements per cycle depends on the type of encoding—X1, X2, or X4.

Figure 7-14 shows a quadrature cycle and the resulting increments and decrements for X1 encoding. When channel A leads channel B, the increment occurs on the rising edge of channel A. When channel B leads channel A, the decrement occurs on the falling edge of channel A.

Figure 7-14. X1 Encoding

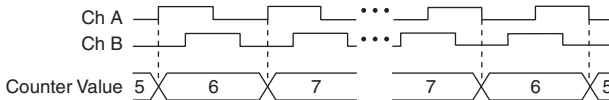

- **X2 Encoding**—The same behavior holds for X2 encoding except the counter increments or decrements on each edge of channel A, depending on which channel leads the other. Each cycle results in two increments or decrements, as shown in Figure 7-15.

Figure 7-15. X2 Encoding

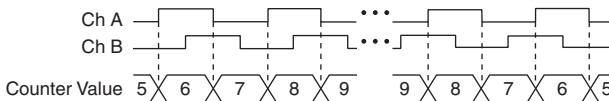

- **X4 Encoding**—Similarly, the counter increments or decrements on each edge of channels A and B for X4 encoding. Whether the counter increments or decrements depends on which channel leads the other. Each cycle results in four increments or decrements, as shown in Figure 7-16.

Figure 7-16. X4 Encoding

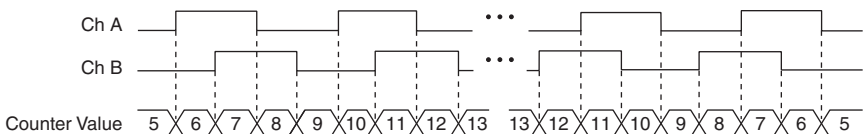

Channel Z Behavior

Some quadrature encoders have a third channel, channel Z, which is also referred to as the index channel. A high level on channel Z causes the counter to be reloaded with a specified value in a specified phase of the quadrature cycle. You can program this reload to occur in any one of the four phases in a quadrature cycle.

Channel Z behavior—when it goes high and how long it stays high—differs with quadrature encoder designs. You must refer to the documentation for your quadrature encoder to obtain timing of channel Z with respect to channels A and B. You must then ensure that channel Z is high during at least a portion of the phase you specify for reload. For instance, in Figure 7-17, channel Z is never high when channel A is high and channel B is low. Thus, the reload must occur in some other phase.

In Figure 7-17, the reload phase is when both channel A and channel B are low. The reload occurs when this phase is true and channel Z is high. Incrementing and decrementing takes priority over reloading. Thus, when the channel B goes low to enter the reload phase, the increment occurs first. The reload occurs within one maximum timebase period after the reload phase becomes true. After the reload occurs, the counter continues to count as before. The figure illustrates channel Z reload with X4 decoding.

Figure 7-17. Channel Z Reload with X4 Decoding

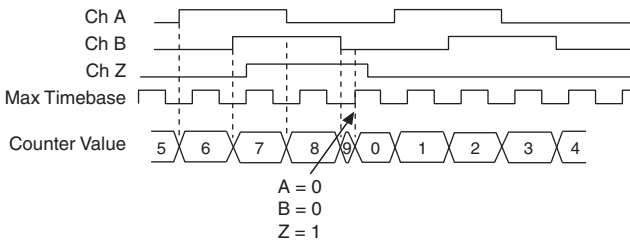

Measurements Using Two Pulse Encoders

The counter supports two pulse encoders that have two channels—channels A and B.

The counter increments on each rising edge of channel A. The counter decrements on each rising edge of channel B, as shown in Figure 7-18.

Figure 7-18. Measurements Using Two Pulse Encoders

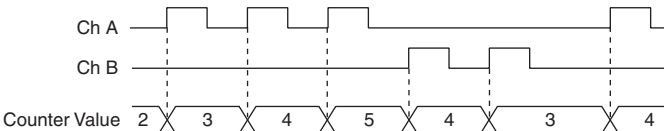

For information about connecting counter signals, refer to the [Default Counter/Timer Pinouts](#) section.

Buffered (Sample Clock) Position Measurement

With buffered position measurement (position measurement using a sample clock), the counter increments based on the encoding used after the counter is armed. The value of the counter is sampled on each active edge of a sample clock. A DMA controller transfers the sampled values to host memory. The count values returned are the cumulative counts since the counter armed event; that is, the sample clock does not reset the counter. You can route the counter sample clock to the Gate input of the counter. You can configure the counter to sample on the rising or falling edge of the sample clock.

Figure 7-19 shows an example of a buffered X1 position measurement.

Figure 7-19. Buffered Position Measurement

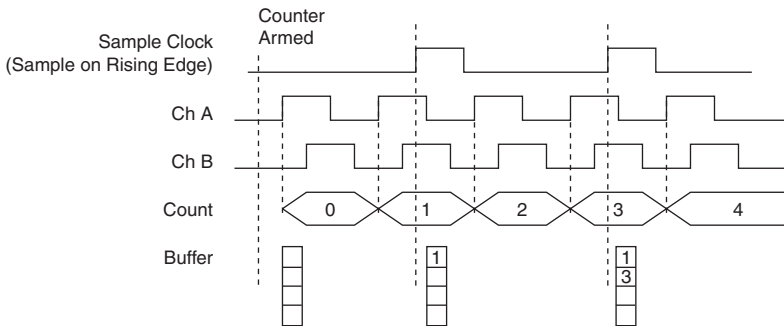

Two-Signal Edge-Separation Measurement

Two-signal edge-separation measurement is similar to pulse-width measurement, except that there are two measurement signals—Aux and Gate. An active edge on the Aux input starts the counting and an active edge on the Gate input stops the counting. You must arm a counter to begin a two edge separation measurement.

After the counter has been armed and an active edge occurs on the Aux input, the counter counts the number of rising (or falling) edges on the Source. The counter ignores additional edges on the Aux input.

The counter stops counting upon receiving an active edge on the Gate input. The counter stores the count in a hardware save register.

You can configure the rising or falling edge of the Aux input to be the active edge. You can configure the rising or falling edge of the Gate input to be the active edge.

Use this type of measurement to count events or measure the time that occurs between edges on two signals. This type of measurement is sometimes referred to as start/stop trigger measurement, second gate measurement, or A-to-B measurement.

Refer to the following sections for more information about the M Series edge-separation measurement options:

- [Single Two-Signal Edge-Separation Measurement](#)
- [Buffered Two-Signal Edge-Separation Measurement](#)

Single Two-Signal Edge-Separation Measurement

With single two-signal edge-separation measurement, the counter counts the number of rising (or falling) edges on the Source input occurring between an active edge of the Gate signal and an active edge of the Aux signal. The counter then stores the count in a hardware save register and ignores other edges on its inputs. Software then reads the stored count.

Figure 7-20 shows an example of a single two-signal edge-separation measurement.

Figure 7-20. Single Two-Signal Edge-Separation Measurement

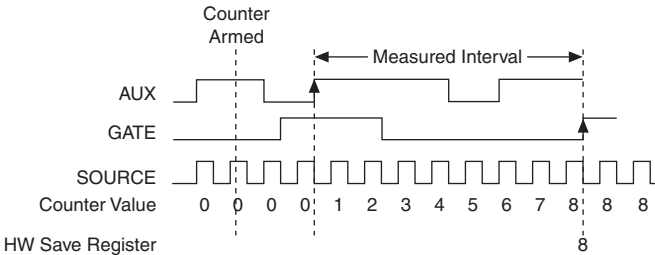

Buffered Two-Signal Edge-Separation Measurement

Buffered and single two-signal edge-separation measurements are similar, but buffered measurement measures multiple intervals.

The counter counts the number of rising (or falling) edges on the Source input occurring between an active edge of the Gate signal and an active edge of the Aux signal. The counter then stores the count in a hardware save register. On the next active edge of the Gate signal, the counter begins another measurement. A DMA controller transfers the stored values to host memory.

Figure 7-21 shows an example of a buffered two-signal edge-separation measurement.

Figure 7-21. Buffered Two-Signal Edge-Separation Measurement

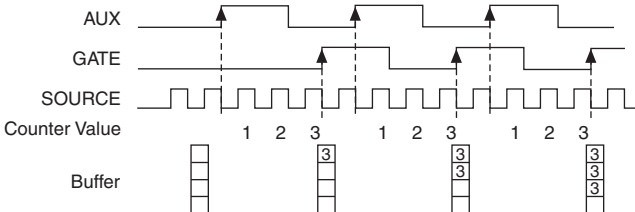

For information about connecting counter signals, refer to the [Default Counter/Timer Pinouts](#) section.

Counter Output Applications

The following sections list the various counter output applications available on M series devices:

- [Simple Pulse Generation](#)
- [Pulse Train Generation](#)
- [Frequency Generation](#)
- [Frequency Division](#)
- [Pulse Generation for ETS](#)

Simple Pulse Generation

Refer to the following sections for more information about the M Series simple pulse generation options:

- [Single Pulse Generation](#)
- [Single Pulse Generation with Start Trigger](#)
- [Retriggerable Single Pulse Generation](#)

Single Pulse Generation

The counter can output a single pulse. The pulse appears on the Counter *n* Internal Output signal of the counter.

You can specify a delay from when the counter is armed to the beginning of the pulse. The delay is measured in terms of a number of active edges of the Source input.

You can specify a pulse width. The pulse width is also measured in terms of a number of active edges of the Source input. You also can specify the active edge of the Source input (rising or falling).

Figure 7-22 shows a generation of a pulse with a pulse delay of four and a pulse width of three (using the rising edge of Source).

Figure 7-22. Single Pulse Generation

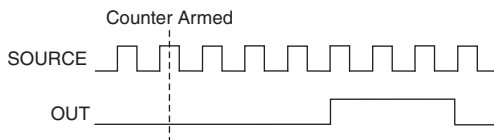

Single Pulse Generation with Start Trigger

The counter can output a single pulse in response to one pulse on a hardware Start Trigger signal. The pulse appears on the Counter *n* Internal Output signal of the counter.

You can route the Start Trigger signal to the Gate input of the counter. You can specify a delay from the Start Trigger to the beginning of the pulse. You also can specify the pulse width. The delay and pulse width are measured in terms of a number of active edges of the Source input.

After the Start Trigger signal pulses once, the counter ignores the Gate input.

Figure 7-23 shows a generation of a pulse with a pulse delay of four and a pulse width of three (using the rising edge of Source).

Figure 7-23. Single Pulse Generation with Start Trigger

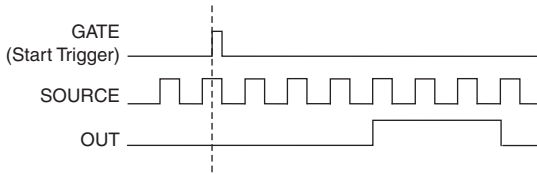

Retriggerable Single Pulse Generation

The counter can output a single pulse in response to each pulse on a hardware Start Trigger signal. The pulses appear on the Counter *n* Internal Output signal of the counter.

You can route the Start Trigger signal to the Gate input of the counter. You can specify a delay from the Start Trigger to the beginning of each pulse. You also can specify the pulse width. The delay and pulse width are measured in terms of a number of active edges of the Source input.

The counter ignores the Gate input while a pulse generation is in progress. After the pulse generation is finished, the counter waits for another Start Trigger signal to begin another pulse generation.

Figure 7-24 shows a generation of two pulses with a pulse delay of five and a pulse width of three (using the rising edge of Source).

Figure 7-24. Retriggerable Single Pulse Generation

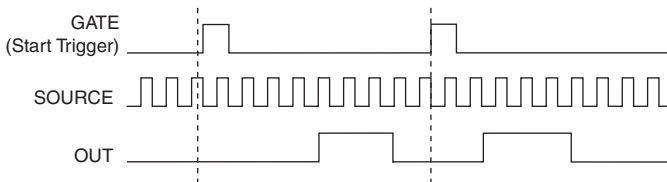

For information about connecting counter signals, refer to the [Default Counter/Timer Pinouts](#) section.

Pulse Train Generation

Refer to the following sections for more information about the M Series pulse train generation options:

- [Continuous Pulse Train Generation](#)
- [Finite Pulse Train Generation](#)

Continuous Pulse Train Generation

This function generates a train of pulses with programmable frequency and duty cycle. The pulses appear on the Counter n Internal Output signal of the counter.

You can specify a delay from when the counter is armed to the beginning of the pulse train. The delay is measured in terms of a number of active edges of the Source input.

You specify the high and low pulse widths of the output signal. The pulse widths are also measured in terms of a number of active edges of the Source input. You also can specify the active edge of the Source input (rising or falling).

The counter can begin the pulse train generation as soon as the counter is armed, or in response to a hardware Start Trigger. You can route the Start Trigger to the Gate input of the counter.

You also can use the Gate input of the counter as a Pause Trigger (if it is not used as a Start Trigger). The counter pauses pulse generation when the Pause Trigger is active.

Figure 7-25 shows a continuous pulse train generation (using the rising edge of Source).

Figure 7-25. Continuous Pulse Train Generation

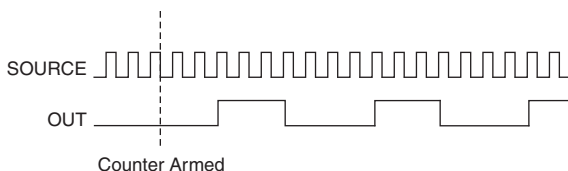

Continuous pulse train generation is sometimes called frequency division. If the high and low pulse widths of the output signal are M and N periods, then the frequency of the Counter n Internal Output signal is equal to the frequency of the Source input divided by $M + N$.

For information about connecting counter signals, refer to the [Default Counter/Timer Pinouts](#) section.

Finite Pulse Train Generation

This function generates a train of pulses of predetermined duration. This counter operation requires both counters. The first counter (for this example, Counter 0) generates a pulse of desired width. The second counter, Counter 1, generates the pulse train, which is gated by the pulse of the first counter. The routing is done internally. Figure 7-26 shows an example finite pulse train timing diagram.

Figure 7-26. Finite Pulse Train Timing Diagram

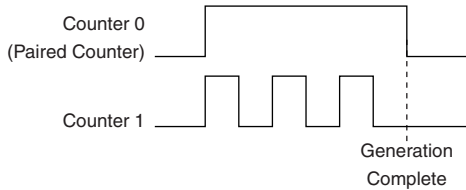

Frequency Generation

You can generate a frequency by using a counter in pulse train generation mode or by using the frequency generator circuit, as described in the [Using the Frequency Generator](#) section.

Using the Frequency Generator

The frequency generator can output a square wave at many different frequencies. The frequency generator is independent of the two general-purpose 32-bit counter/timer modules on M Series devices.

Figure 7-27 shows a block diagram of the frequency generator.

Figure 7-27. Frequency Generator Block Diagram

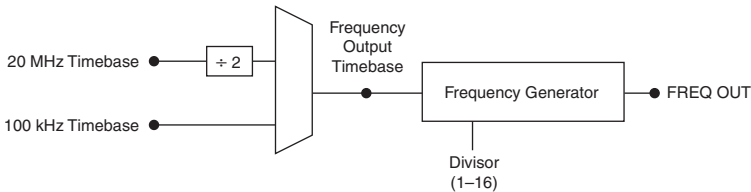

The frequency generator generates the Frequency Output signal. The Frequency Output signal is the Frequency Output Timebase divided by a number you select from 1 to 16. The Frequency Output Timebase can be either the 20 MHz Timebase divided by 2 or the 100 kHz Timebase.

The duty cycle of Frequency Output is 50% if the divider is either 1 or an even number. For an odd divider, suppose the divider is set to D . In this case, Frequency Output is low for $(D + 1)/2$ cycles and high for $(D - 1)/2$ cycles of the Frequency Output Timebase.

Figure 7-28 shows the output waveform of the frequency generator when the divider is set to 5.

Figure 7-28. Frequency Generator Output Waveform

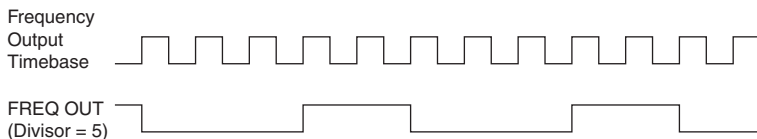

Frequency Output can be routed out to any PFI <0..15> or RTSI <0..7> terminal. All PFI terminals are set to high-impedance at startup. The FREQ OUT signal also can be routed to DO Sample Clock and DI Sample Clock.

In software, program the frequency generator as you would program one of the counters for pulse train generation.

For information about connecting counter signals, refer to the [Default Counter/Timer Pinouts](#) section.

Frequency Division

The counters can generate a signal with a frequency that is a fraction of an input signal. This function is equivalent to continuous pulse train generation. Refer to the [Continuous Pulse Train Generation](#) section for detailed information.

For information about connecting counter signals, refer to the [Default Counter/Timer Pinouts](#) section.

Pulse Generation for ETS

In the equivalent time sampling (ETS) application, the counter produces a pulse on the output a specified delay after an active edge on Gate. After each active edge on Gate, the counter cumulatively increments the delay between the Gate and the pulse on the output by a specified amount. Thus, the delay between the Gate and the pulse produced successively increases.

The increase in the delay value can be between 0 and 255. For instance, if you specify the increment to be 10, the delay between the active Gate edge and the pulse on the output increases by 10 every time a new pulse is generated.

Suppose you program your counter to generate pulses with a delay of 100 and pulse width of 200 each time it receives a trigger. Furthermore, suppose you specify the delay increment to be 10. On the first trigger, your pulse delay will be 100, on the second it will be 110, on the third it will be 120; the process will repeat in this manner until the counter is disarmed. The counter ignores any Gate edge that is received while the pulse triggered by the previous Gate edge is in progress.

The waveform thus produced at the counter's output can be used to provide timing for undersampling applications where a digitizing system can sample repetitive waveforms that are higher in frequency than the Nyquist frequency of the system. Figure 7-29 shows an example of pulse generation for ETS; the delay from the trigger to the pulse increases after each subsequent Gate active edge.

Figure 7-29. Pulse Generation for ETS

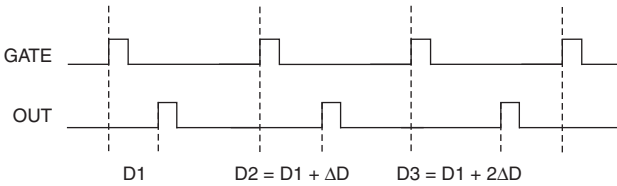

For information about connecting counter signals, refer to the [Default Counter/Timer Pinouts](#) section.

Counter Timing Signals

M Series devices feature the following counter timing signals:

- [Counter *n* Source Signal](#)
- [Counter *n* Gate Signal](#)
- [Counter *n* Aux Signal](#)
- [Counter *n* A Signal](#)
- [Counter *n* B Signal](#)
- [Counter *n* Z Signal](#)
- [Counter *n* Up_Down Signal](#)
- [Counter *n* HW Arm Signal](#)
- [Counter *n* Internal Output Signal](#)
- [Counter *n* TC Signal](#)
- [Frequency Output Signal](#)

In this section, *n* refers to either Counter 0 or 1. For example, Counter *n* Source refers to two signals—Counter 0 Source (the source input to Counter 0) and Counter 1 Source (the source input to Counter 1).

Counter *n* Source Signal

The selected edge of the Counter *n* Source signal increments and decrements the counter value depending on the application the counter is performing. Table 7-5 lists how this terminal is used in various applications.

Table 7-5. Counter Applications and Counter *n* Source

Application	Purpose of Source Terminal
Pulse Generation	Counter Timebase
One Counter Time Measurements	Counter Timebase
Two Counter Time Measurements	Input Terminal
Non-Buffered Edge Counting	Input Terminal
Buffered Edge Counting	Input Terminal
Two-Edge Separation	Counter Timebase

Routing a Signal to Counter *n* Source

Each counter has independent input selectors for the Counter *n* Source signal. Any of the following signals can be routed to the Counter *n* Source input:

- 80 MHz Timebase
- 20 MHz Timebase
- 100 kHz Timebase
- RTSI <0..7>
- PFI <0..15>
- PXI_CLK10
- PXI_STAR
- Analog Comparison Event

In addition, Counter 1 TC or Counter 1 Gate can be routed to Counter 0 Source. Counter 0 TC or Counter 0 Gate can be routed to Counter 1 Source.

Some of these options may not be available in some driver software.

Routing Counter *n* Source to an Output Terminal

You can route Counter *n* Source out to any PFI <0..15> or RTSI <0..7> terminal. All PFIs are set to high-impedance at startup.

Counter *n* Gate Signal

The Counter *n* Gate signal can perform many different operations depending on the application including starting and stopping the counter, and saving the counter contents.

Routing a Signal to Counter n Gate

Each counter has independent input selectors for the Counter n Gate signal. Any of the following signals can be routed to the Counter n Gate input:

- RTSI <0..7>
- PFI <0..15>
- AI Reference Trigger (ai/ReferenceTrigger)
- AI Start Trigger (ai/StartTrigger)
- AI Sample Clock (ai/SampleClock)
- AI Convert Clock (ai/ConvertClock)
- AO Sample Clock (ao/SampleClock)
- DI Sample Clock (di/SampleClock)
- DO Sample Clock (do/SampleClock)
- PXI_STAR
- Change Detection Event
- Analog Comparison Event

In addition, Counter 1 Internal Output or Counter 1 Source can be routed to Counter 0 Gate. Counter 0 Internal Output or Counter 0 Source can be routed to Counter 1 Gate.

Some of these options may not be available in some driver software.

Routing Counter n Gate to an Output Terminal

You can route Counter n Gate out to any PFI <0..15> or RTSI <0..7> terminal. All PFIs are set to high-impedance at startup.

Counter n Aux Signal

The Counter n Aux signal indicates the first edge in a two-signal edge-separation measurement.

Routing a Signal to Counter n Aux

Each counter has independent input selectors for the Counter n Aux signal. Any of the following signals can be routed to the Counter n Aux input:

- RTSI <0..7>
- PFI <0..15>
- AI Reference Trigger (ai/ReferenceTrigger)
- AI Start Trigger (ai/StartTrigger)
- PXI_STAR
- Analog Comparison Event

In addition, Counter 1 Internal Output, Counter 1 Gate, Counter 1 Source, or Counter 0 Gate can be routed to Counter 0 Aux. Counter 0 Internal Output, Counter 0 Gate, Counter 0 Source, or Counter 1 Gate can be routed to Counter 1 Aux.

Some of these options may not be available in some driver software.

Counter n A, Counter n B, and Counter n Z Signals

Counter n B can control the direction of counting in edge counting applications. Use the A, B, and Z inputs to each counter when measuring quadrature encoders or measuring two pulse encoders.

Routing Signals to A, B, and Z Counter Inputs

Each counter has independent input selectors for each of the A, B, and Z inputs. Any of the following signals can be routed to each input:

- RTSI <0..7>
- PFI <0..15>
- PXI_STAR
- Analog Comparison Event

Routing Counter n Z Signal to an Output Terminal

You can route Counter n Z out to RTSI <0..7>.

Counter n Up_Down Signal

Counter n Up_Down is another name for the Counter n B signal.

Counter n HW Arm Signal

The Counter n HW Arm signal enables a counter to begin an input or output function.

To begin any counter input or output function, you must first enable, or arm, the counter. In some applications, such as buffered semi-period measurement, the counter begins counting when it is armed. In other applications, such as single pulse-width measurement, the counter begins waiting for the Gate signal when it is armed. Counter output operations can use the arm signal in addition to a start trigger.

Software can arm a counter or configure counters to be armed on a hardware signal. Software calls this hardware signal the Arm Start Trigger. Internally, software routes the Arm Start Trigger to the Counter n HW Arm input of the counter.

Routing Signals to Counter n HW Arm Input

Any of the following signals can be routed to the Counter n HW Arm input:

- RTSI <0..7>
- PFI <0..15>

- AI Reference Trigger (ai/ReferenceTrigger)
- AI Start Trigger (ai/StartTrigger)
- PXI_STAR
- Analog Comparison Event

Counter 1 Internal Output can be routed to Counter 0 HW Arm. Counter 0 Internal Output can be routed to Counter 1 HW Arm.

Some of these options may not be available in some driver software.

Counter n Internal Output and Counter n TC Signals

The Counter n Internal Output signal changes in response to Counter n TC.

The two software-selectable output options are pulse output on TC and toggle output on TC. The output polarity is software-selectable for both options.

With pulse or pulse train generation tasks, the counter drives the pulse(s) on the Counter n Internal Output signal. The Counter n Internal Output signal can be internally routed to be a counter/timer input or an “external” source for AI, AO, DI, or DO timing signals.

Routing Counter n Internal Output to an Output Terminal

You can route Counter n Internal Output to any PFI <0..15> or RTSI <0..7> terminal. All PFIs are set to high-impedance at startup.

Frequency Output Signal

The Frequency Output (FREQ OUT) signal is the output of the frequency output generator.

Routing Frequency Output to a Terminal

You can route Frequency Output to any PFI <0..15> terminal. All PFIs are set to high-impedance at startup. The FREQ OUT signal also can be routed to DO Sample Clock and DI Sample Clock.

Default Counter/Timer Pinouts

By default, NI-DAQmx routes the counter/timer inputs and outputs to the PFI pins, shown in Table 7-6. To find the default NI-DAQmx counter/timer pins for the PCI-6221 (37-pin), USB-62xx Screw Terminal, and USB-62xx BNC devices, refer to Appendix A, [Module/Device-Specific Information](#).

Table 7-6. 68-Pin Device Default NI-DAQmx Counter/Timer Pins

Counter/Timer Signal	Default Connector 0 Pin Number (Name)
CTR 0 SRC	37 (PFI 8)
CTR 0 GATE	3 (PFI 9)
CTR 0 AUX	45 (PFI 10)
CTR 0 OUT	2 (PFI 12)
CTR 0 A	37 (PFI 8)
CTR 0 Z	3 (PFI 9)
CTR 0 B	45 (PFI 10)
CTR 1 SRC	42 (PFI 3)
CTR 1 GATE	41 (PFI 4)
CTR 1 AUX	46 (PFI 11)
CTR 1 OUT	40 (PFI 13)
CTR 1 A	42 (PFI 3)
CTR 1 Z	41 (PFI 4)
CTR 1 B	46 (PFI 11)
FREQ OUT	1 (PFI 14)

You can use these defaults or select other sources and destinations for the counter/timer signals in NI-DAQmx. Refer to *Connecting Counter Signals* in the *NI-DAQmx Help* or the *LabVIEW Help* for more information about how to connect your signals for common counter measurements and generations. M Series default PFI lines for counter functions are listed in *Physical Channels* in the *NI-DAQmx Help* or the *LabVIEW Help*.

Counter Triggering

Counters support three different triggering actions:

- **Arm Start Trigger**—To begin any counter input or output function, you must first enable, or arm, the counter. Software can arm a counter or configure counters to be armed on a hardware signal. Software calls this hardware signal the Arm Start Trigger. Internally, software routes the Arm Start Trigger to the Counter *n* HW Arm input of the counter. ArmStart.DigEdge.Edge is not supported on M Series devices and modules.

For counter output operations, you can use it in addition to the start and pause triggers. For counter input operations, you can use the arm start trigger to have start trigger-like behavior. The arm start trigger can be used for synchronizing multiple counter input and output tasks.

When using an arm start trigger, the arm start trigger source is routed to the Counter n HW Arm signal.

- **Start Trigger**—For counter output operations, a start trigger can be configured to begin a finite or continuous pulse generation. Once a continuous generation has triggered, the pulses continue to generate until you stop the operation in software. For finite generations, the specified number of pulses is generated and the generation stops unless you use the retriggerable attribute. When you use this attribute, subsequent start triggers cause the generation to restart.

Counter input operations can use the arm start trigger to have start trigger-like behavior.

When using a start trigger, the start trigger source is routed to the Counter n Gate signal input of the counter.

- **Pause Trigger**—You can use pause triggers in edge counting and continuous pulse generation applications. For edge counting acquisitions, the counter stops counting edges while the external trigger signal is low and resumes when the signal goes high or vice versa. For continuous pulse generations, the counter stops generating pulses while the external trigger signal is low and resumes when the signal goes high or vice versa.

When using a pause trigger, the pause trigger source is routed to the Counter n Gate signal input of the counter.

Other Counter Features

The following sections list the other counter features available on M Series devices.

Cascading Counters

You can internally route the Counter n Internal Output and Counter n TC signals of each counter to the Gate inputs of the other counter. By cascading two counters together, you can effectively create a 64-bit counter. By cascading counters, you also can enable other applications. For example, to improve the accuracy of frequency measurements, use reciprocal frequency measurement, as described in the [Large Range of Frequencies with Two Counters](#) section.

Counter Filters

You can enable a programmable debouncing filter on each PFI, RTSI, or PXI_STAR signal. When the filters are enabled, your device samples the input on each rising edge of a filter clock. M Series devices use an onboard oscillator to generate the filter clock with a 40 MHz frequency.



Note NI-DAQmx *only* supports filters on counter inputs.

The following is an example of low to high transitions of the input signal. High to low transitions work similarly.

Assume that an input terminal has been low for a long time. The input terminal then changes from low to high, but glitches several times. When the filter clock has sampled the signal high on N consecutive edges, the low to high transition is propagated to the rest of the circuit. The value of N depends on the filter setting; refer to Table 7-7.

Table 7-7. Filters

Filter Setting	N (Filter Clocks Needed to Pass Signal)	Pulse Width Guaranteed to Pass Filter	Pulse Width Guaranteed to Not Pass Filter
125 ns	5	125 ns	100 ns
6.425 μ s	257	6.425 μ s	6.400 μ s
2.56 ms	~101,800	2.56 ms	2.54 ms
Disabled	—	—	—

The filter setting for each input can be configured independently. On power up, the filters are disabled. Figure 7-30 shows an example of a low to high transition on an input that has its filter set to 125 ns ($N = 5$).

Figure 7-30. Filter Example

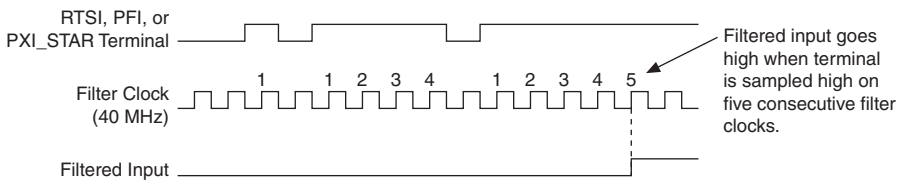

Enabling filters introduces jitter on the input signal. For the 125 ns and 6.425 μ s filter settings, the jitter is up to 25 ns. On the 2.56 ms setting, the jitter is up to 10.025 μ s.

When a PFI input is routed directly to RTSI, or a RTSI input is routed directly to PFI, the M Series device does not use the filtered version of the input signal.

Refer to the KnowledgeBase document, *Digital Filtering with M Series and CompactDAQ*, for more information about digital filters and counters. To access this KnowledgeBase, go to ni.com/info and enter the Info Code `rddfms`.

Prescaling

Prescaling allows the counter to count a signal that is faster than the maximum timebase of the counter. M Series devices offer 8X and 2X prescaling on each counter (prescaling can be disabled). Each prescaler consists of a small, simple counter that counts to eight (or two) and rolls over. This counter can run faster than the larger counters, which simply count the rollovers of this smaller counter. Thus, the prescaler acts as a frequency divider on the Source and puts out a frequency that is one-eighth (or one-half) of what it is accepting.

Figure 7-31. Prescaling

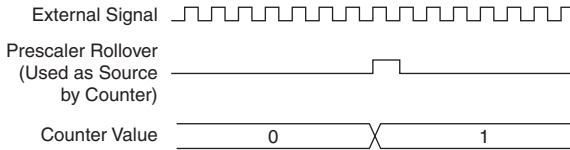

Prescaling is intended to be used for frequency measurement where the measurement is made on a continuous, repetitive signal. The prescaling counter cannot be read; therefore, you cannot determine how many edges have occurred since the previous rollover. Prescaling can be used for event counting provided it is acceptable to have an error of up to seven (or one). Prescaling can be used when the counter Source is an external signal. Prescaling is not available if the counter Source is one of the internal timebases (80MHzTimebase, 20MHzTimebase, or 100kHzTimebase).

Duplicate Count Prevention

Duplicate count prevention (or synchronous counting mode) ensures that a counter returns correct data in applications that use a slow or non-periodic external source. Duplicate count prevention applies only to buffered counter applications such as measuring frequency or period. In such buffered applications, the counter should store the number of times an external Source pulses between rising edges on the Gate signal.

Example Application That Works Correctly (No Duplicate Counting)

Figure 7-32 shows an external buffered signal as the period measurement Source.

Figure 7-32. Duplicate Count Prevention Example

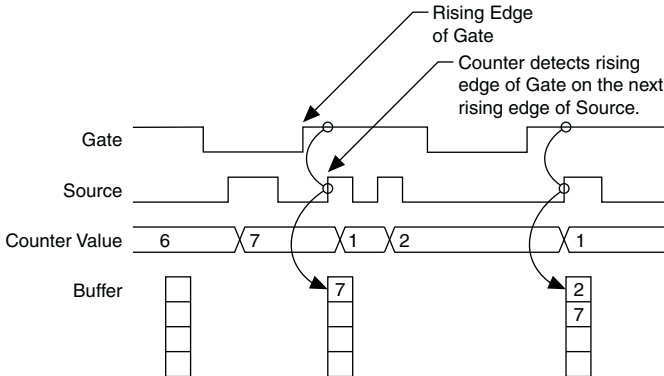

On the first rising edge of the Gate, the current count of 7 is stored. On the next rising edge of the Gate, the counter stores a 2 since two Source pulses occurred after the previous rising edge of Gate.

The counter synchronizes or samples the Gate signal with the Source signal, so the counter does not detect a rising edge in the Gate until the next Source pulse. In this example, the counter stores the values in the buffer on the first rising Source edge after the rising edge of Gate. The details of when exactly the counter synchronizes the Gate signal vary depending on the synchronization mode. Synchronization modes are described in the [Synchronization Modes](#) section.

Example Application That Works Incorrectly (Duplicate Counting)

In Figure 7-33, after the first rising edge of Gate, no Source pulses occur, so the counter does not write the correct data to the buffer.

Figure 7-33. Duplicate Count Example

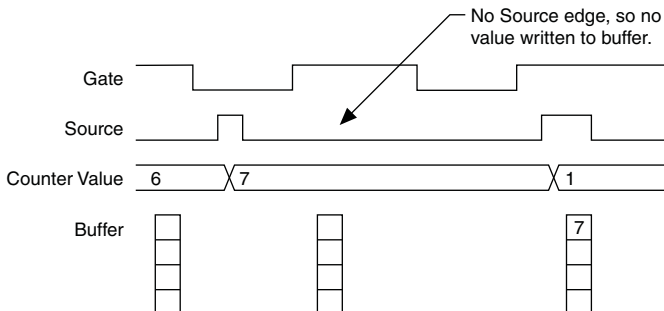

Example Application That Prevents Duplicate Count

With duplicate count prevention enabled, the counter synchronizes both the Source and Gate signals to the 80 MHz Timebase. By synchronizing to the timebase, the counter detects edges on the Gate even if the Source does not pulse. This enables the correct current count to be stored in the buffer even if no Source edges occur between Gate signals, as shown in Figure 7-34.

Figure 7-34. Duplicate Count Prevention Example

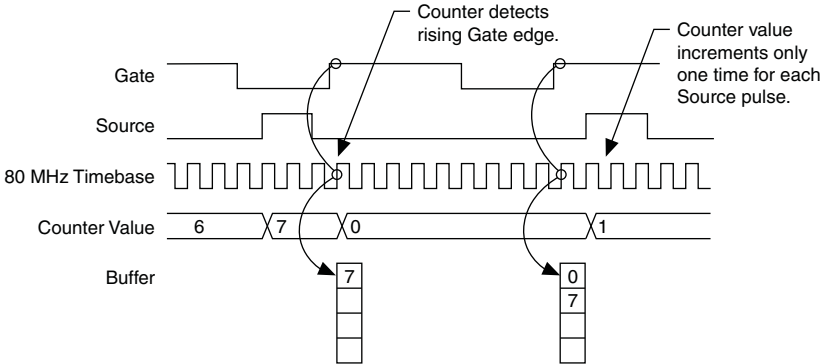

Even if the Source pulses are long, the counter increments only once for each Source pulse.

Normally, the counter value and Counter *n* Internal Output signals change synchronously to the Source signal. With duplicate count prevention, the counter value and Counter *n* Internal Output signals change synchronously to the 80 MHz Timebase.

Note that duplicate count prevention should only be used if the frequency of the Source signal is 20 MHz or less.

When To Use Duplicate Count Prevention

You should use duplicate count prevention if the following conditions are true:

- You are making a counter measurement.
- You are using an external signal (such as PFI *x*) as the counter Source.
- The frequency of the external source is 20 MHz or less.
- You can have the counter value and output to change synchronously with the 80 MHz Timebase.

In all other cases, you should *not* use duplicate count prevention.

Enabling Duplicate Count Prevention in NI-DAQmx

You can enable duplicate count prevention in NI-DAQmx by setting the **Enable Duplicate Count Prevention** attribute/property. For specific information about finding the **Enable Duplicate Count Prevention** attribute/property, refer to the help file for the API you are using.

Synchronization Modes

The 32-bit counter counts up or down synchronously with the Source signal. The Gate signal and other counter inputs are asynchronous to the Source signal. So M Series devices synchronize these signals before presenting them to the internal counter.

M Series devices use one of three synchronization methods:

- *80 MHz Source Mode*
- *Other Internal Source Mode*
- *External Source Mode*

In DAQmx, the device uses 80 MHz source mode if you perform the following:

- Perform a position measurement
- Select duplicate count prevention

Otherwise, the mode depends on the signal that drives Counter n Source. Table 7-8 describes the conditions for each mode.

Table 7-8. Synchronization Mode Conditions

Duplicate Count Prevention Enabled	Type of Measurement	Signal Driving Counter n Source	Synchronization Mode
Yes	Any	Any	80 MHz Source
No	Position Measurement	Any	80 MHz Source
No	Any	80 MHz Timebase	80 MHz Source
No	All Except Position Measurement	20 MHz Timebase, 100 kHz Timebase, or PXI_CLK10	Other Internal Source
No	All Except Position Measurement	Any Other Signal (such as PFI or RTSI)	External Source

80 MHz Source Mode

In 80 MHz source mode, the device synchronizes signals on the rising edge of the source, and counts on the following rising edge of the source, as shown in Figure 7-35.

Figure 7-35. 80 MHz Source Mode



Other Internal Source Mode

In other internal source mode, the device synchronizes signals on the falling edge of the source, and counts on the following rising edge of the source, as shown in Figure 7-36.

Figure 7-36. Other Internal Source Mode

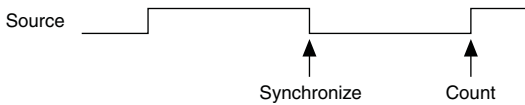

External Source Mode

In external source mode, the device generates a delayed Source signal by delaying the Source signal by several nanoseconds. The device synchronizes signals on the rising edge of the delayed Source signal, and counts on the following rising edge of the source, as shown in Figure 7-37.

Figure 7-37. External Source Mode

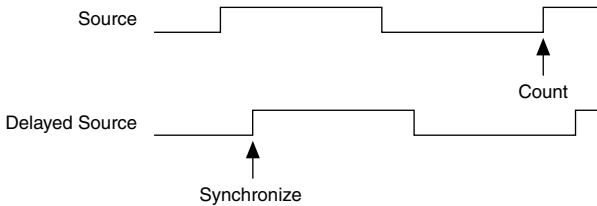

PFI

M Series devices have up to 16 Programmable Function Interface (PFI) signals. In addition, M Series devices have up to 32 lines of bidirectional DIO signals.

Each PFI can be individually configured as the following:

- A static digital input
- A static digital output
- A timing input signal for AI, AO, DI, DO, or counter/timer functions
- A timing output signal from AI, AO, DI, DO, or counter/timer functions

Each PFI input also has a programmable debouncing filter. Figure 8-1 shows the circuitry of one PFI line. Each PFI line is similar.

Figure 8-1. M Series PFI Circuitry

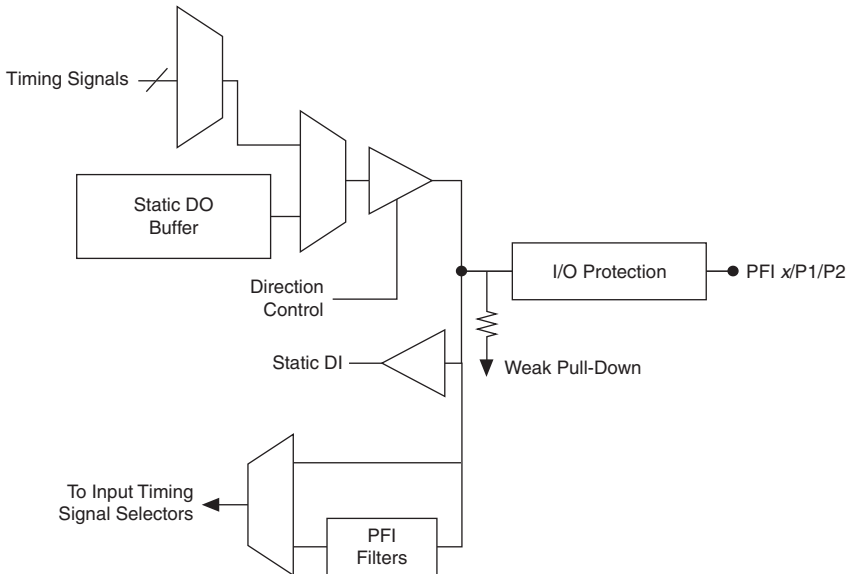

When a terminal is used as a timing input or output signal, it is called PFI x (where x is an integer from 0 to 15). When a terminal is used as a static digital input or output, it is called P1. x or P2. x . On the I/O connector, each terminal is labeled PFI x /P1 or PFI x /P2.

The voltage input and output levels and the current drive levels of the PFI signals are listed in the specifications of your device.

Using PFI Terminals as Timing Input Signals

Use PFI terminals to route external timing signals to many different M Series functions. Each PFI terminal can be routed to any of the following signals:

- AI Convert Clock (ai/ConvertClock)
- AI Sample Clock (ai/SampleClock)
- AI Start Trigger (ai/StartTrigger)
- AI Reference Trigger (ai/ReferenceTrigger)
- AI Pause Trigger (ai/PauseTrigger)
- AI Sample Clock Timebase (ai/SampleClockTimebase)
- AO Start Trigger (ao/StartTrigger)
- AO Sample Clock (ao/SampleClock)
- AO Sample Clock Timebase (ao/SampleClockTimebase)
- AO Pause Trigger (ao/PauseTrigger)
- Counter input signals for either counter—Source, Gate, Aux, HW_Arm, A, B, Z
- DI Sample Clock (di/SampleClock)
- DO Sample Clock (do/SampleClock)

Most functions allow you to configure the polarity of PFI inputs and whether the input is edge or level sensitive.

Exporting Timing Output Signals Using PFI Terminals

You can route any of the following timing signals to any PFI terminal configured as an output:

- AI Convert Clock* (ai/ConvertClock)
- AI Hold Complete Event (ai/HoldCompleteEvent)
- AI Reference Trigger (ai/ReferenceTrigger)
- AI Sample Clock (ai/SampleClock)
- AI Start Trigger (ai/StartTrigger)
- AO Sample Clock* (ao/SampleClock)
- AO Start Trigger (ao/StartTrigger)
- Counter *n* Source
- Counter *n* Gate
- Counter *n* Internal Output

- Frequency Output
- PXI_STAR
- RTSI <0..7>
- Analog Comparison Event
- Change Detection Event
- DI Sample Clock* (di/SampleClock)
- DO Sample Clock* (do/SampleClock)



Note Signals with a * are inverted before being driven to a terminal; that is, these signals are active low.

Using PFI Terminals as Static Digital I/Os

Each PFI can be individually configured as a static digital input or a static digital output. When a terminal is used as a static digital input or output, it is called P1.x or P2.x. On the I/O connector, each terminal is labeled PFI x/P1.x or PFI x/P2.x.

In addition, M Series devices have up to 32 lines of bidirectional DIO signals.

Connecting PFI Input Signals

All PFI input connections are referenced to D GND. Figure 8-2 shows this reference, and how to connect an external PFI 0 source and an external PFI 2 source to two PFI terminals.

Figure 8-2. PFI Input Signals Connections

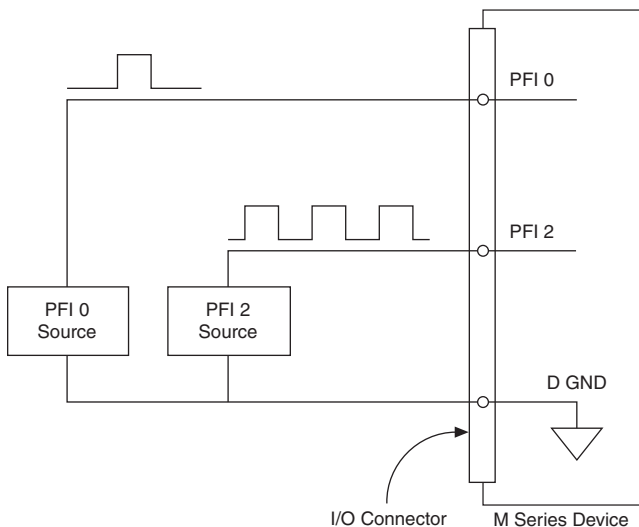

PFI Filters

You can enable a programmable debouncing filter on each PFI, RTSI, or PXI_STAR signal. When the filters are enabled, your device samples the input on each rising edge of a filter clock. M Series devices use an onboard oscillator to generate the filter clock with a 40 MHz frequency.



Note NI-DAQmx *only* supports filters on counter inputs.

The following is an example of low to high transitions of the input signal. High to low transitions work similarly.

Assume that an input terminal has been low for a long time. The input terminal then changes from low to high, but glitches several times. When the filter clock has sampled the signal high on N consecutive edges, the low to high transition is propagated to the rest of the circuit. The value of N depends on the filter setting; refer to Table 8-1.

Table 8-1. Filters

Filter Setting	N (Filter Clocks Needed to Pass Signal)	Pulse Width Guaranteed to Pass Filter	Pulse Width Guaranteed to Not Pass Filter
125 ns	5	125 ns	100 ns
6.425 μ s	257	6.425 μ s	6.400 μ s
2.56 ms	~101,800	2.56 ms	2.54 ms
Disabled	—	—	—

The filter setting for each input can be configured independently. On power up, the filters are disabled. Figure 8-3 shows an example of a low to high transition on an input that has its filter set to 125 ns (N = 5).

Figure 8-3. Filter Example

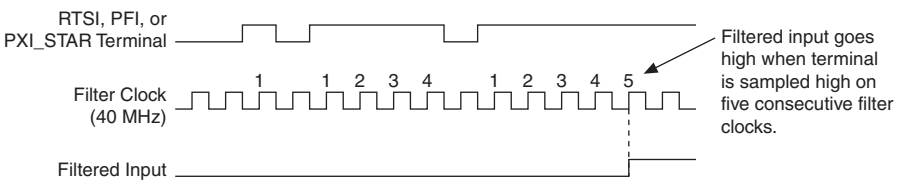

Enabling filters introduces jitter on the input signal. For the 125 ns and 6.425 μ s filter settings, the jitter is up to 25 ns. On the 2.56 ms setting, the jitter is up to 10.025 μ s.

When a PFI input is routed directly to RTSI, or a RTSI input is routed directly to PFI, the M Series device does not use the filtered version of the input signal.

Refer to the KnowledgeBase document, *Digital Filtering with M Series and CompactDAQ*, for more information about digital filters and counters. To access this KnowledgeBase, go to ni.com/info and enter the Info Code `rddfms`.

I/O Protection

Each DIO and PFI signal is protected against overvoltage, undervoltage, and overcurrent conditions as well as ESD events. However, you should avoid these fault conditions by following these guidelines:

- If you configure a PFI or DIO line as an output, do *not* connect it to any external signal source, ground, or power supply.
- If you configure a PFI or DIO line as an output, understand the current requirements of the load connected to these signals. Do *not* exceed the specified current output limits of the DAQ device. NI has several signal conditioning solutions for digital applications requiring high current drive.
- If you configure a PFI or DIO line as an input, do *not* drive the line with voltages outside of its normal operating range. The PFI or DIO lines have a smaller operating range than the AI signals.
- Treat the DAQ device as you would treat any static sensitive device. *Always* properly ground yourself and the equipment when handling the DAQ device or connecting to it.

Programmable Power-Up States

At system startup and reset, the hardware sets all PFI and DIO lines to high-impedance inputs by default. The DAQ device does not drive the signal high or low. Each line has a weak pull-down resistor connected to it, as described in the specifications document for your device.

NI-DAQmx supports programmable power-up states for PFI and DIO lines. Software can program any value at power up to the P0, P1, or P2 lines. The PFI and DIO lines can be set as:

- A high-impedance input with a weak pull-down resistor (default)
- An output driving a 0
- An output driving a 1

Refer to the *NI-DAQmx Help* or the *LabVIEW Help* for more information about setting power-up states in NI-DAQmx or MAX.



Note When using your M Series device to control an SCXI chassis, DIO lines 0, 1, 2, and 4 are used as communication lines and must be left to power-up in the default high-impedance state to avoid potential damage to these signals.

Digital Routing and Clock Generation

The digital routing circuitry has the following main functions:

- Manages the flow of data between the bus interface and the acquisition/generation sub-systems (analog input, analog output, digital I/O, and the counters). The digital routing circuitry uses FIFOs (if present) in each sub-system to ensure efficient data movement.
- Routes timing and control signals. The acquisition/generation sub-systems use these signals to manage acquisitions and generations. These signals can come from the following sources:
 - Your M Series device
 - Other devices in your system through RTSI
 - User input through the PFI terminals
 - User input through the PXI_STAR terminal
- Routes and generates the main clock signals for the M Series device.

Clock Routing

Figure 9-1 shows the clock routing circuitry of an M Series device.

Figure 9-1. M Series Clock Routing Circuitry

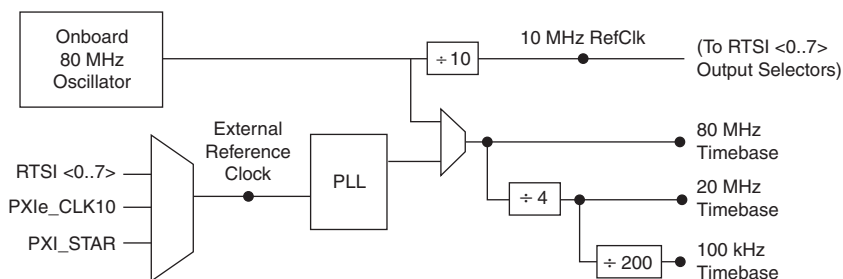

80 MHz Timebase

The 80 MHz Timebase can be used as the Source input to the 32-bit general-purpose counter/timers.

The 80 MHz Timebase is generated from the following sources:

- Onboard oscillator
- External signal (by using the external reference clock)

20 MHz Timebase

The 20 MHz Timebase normally generates many of the AI and AO timing signals. The 20 MHz Timebase also can be used as the Source input to the 32-bit general-purpose counter/timers.

The 20 MHz Timebase is generated by dividing down the 80 MHz Timebase.

100 kHz Timebase

The 100 kHz Timebase can be used to generate many of the AI and AO timing signals. The 100 kHz Timebase also can be used as the Source input to the 32-bit general-purpose counter/timers.

The 100 kHz Timebase is generated by dividing down the 20 MHz Timebase by 200.

External Reference Clock

The external reference clock can be used as a source for the internal timebases (80 MHz Timebase, 20 MHz Timebase, and 100 kHz Timebase) on an M Series device. By using the external reference clock, you can synchronize the internal timebases to an external clock.

The following signals can be routed to drive the external reference clock:

- RTSI <0..7>
- PXI_CLK10
- PXI_STAR

The external reference clock is an input to a Phase-Lock Loop (PLL). The PLL generates the internal timebases.

10 MHz Reference Clock

The 10 MHz reference clock can be used to synchronize other devices to your M Series device. The 10 MHz reference clock can be routed to the RTSI <0..7> terminals. Other devices connected to the RTSI bus can use this signal as a clock input.

The 10 MHz reference clock is generated by dividing down the onboard oscillator.

Synchronizing Multiple Devices

The following sections contain information about synchronizing multiple M Series devices.

PXI/PXI Express Modules

On PXI systems, you can synchronize devices to PXI_CLK10. In this application the PXI chassis acts as the initiator. Each PXI/PXI Express module routes PXI_CLK10 to its external reference clock.

Another option in PXI systems is to use PXI_STAR. The Star Trigger controller device acts as the initiator and drives PXI_STAR with a clock signal. Each target device routes PXI_STAR to its external reference clock.

PCI/PCI Express Devices

With the RTSI and PFI bus and the routing capabilities of M Series PCI/PCI Express devices, there are several ways to synchronize multiple devices depending on your application.

To synchronize multiple devices to a common timebase, choose one device—the initiator—to generate the timebase. The initiator device routes its 10 MHz reference clock to one of the RTSI <0..7> or PFI <0..15> signals.

All devices (including the initiator device) receive the 10 MHz reference clock from RTSI or PFI. This signal becomes the external reference clock. A PLL on each device generates the internal timebases synchronous to the external reference clock.

Once all of the devices are using or referencing a common timebase, you can synchronize operations across them by sending a common start trigger out across the RTSI or PFI bus and setting their sample clock rates to the same value.

USB Devices

With the PFI bus and the routing capabilities of USB M Series devices, there are several ways to synchronize multiple devices depending on your application.

To synchronize multiple devices to a common timebase, choose one device—the initiator—to generate the timebase. The initiator device routes its 10 MHz reference clock to one of the PFI <0..15> signals.

All devices (including the initiator device) receive the 10 MHz reference clock from PFI. This signal becomes the external reference clock. A PLL on each device generates the internal timebases synchronous to the external reference clock.

Once all of the devices are using or referencing a common timebase, you can synchronize operations across them by sending a common start trigger out across the PFI bus and setting their sample clock rates to the same value.

Real-Time System Integration (RTSI)

Real-Time System Integration (RTSI) is a set of bused signals among devices that allows you to do the following:

- Use a common clock (or timebase) to drive the timing engine on multiple devices
- Share trigger signals between devices

Many National Instruments DAQ, Motion, Vision, and CAN devices support RTSI.



Note RTSI is *not* supported on USB devices.

In a PCI/PCI Express system, the RTSI bus consists of the RTSI bus interface and a ribbon cable. The bus can route timing and trigger signals between several functions on as many as five DAQ, vision, motion, or CAN devices in the computer.

In a PXI/PXI Express system, the RTSI bus consists of the RTSI bus interface and the PXI trigger signals on the PXI backplane. This bus can route timing and trigger signals between several functions on as many as seven DAQ devices in the system.

RTSI Connector Pinout

(PCI/PCI Express Devices) Figure 9-2 shows the RTSI connector pinout and Table 9-1 describes the RTSI signals.

Figure 9-2. M Series PCI/PCI Express Device RTSI Pinout

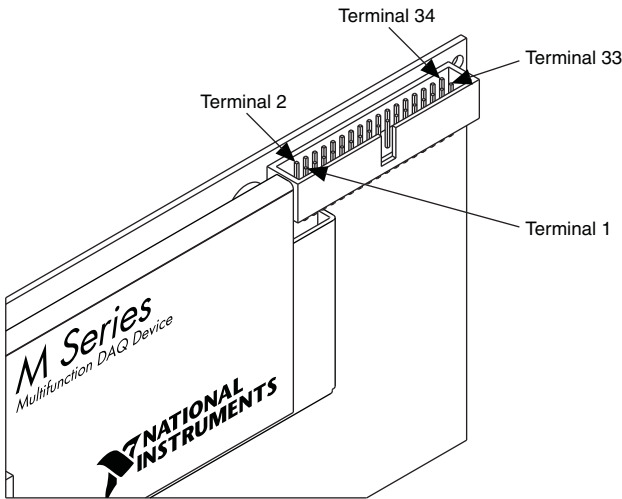

Table 9-1. RTSI Signals

RTSI Bus Signal	Terminal
RTSI 7	34
RTSI 6	32
RTSI 5	30
RTSI 4	28
RTSI 3	26
RTSI 2	24
RTSI 1	22
RTSI 0	20
Not Connected. Do not connect signals to these terminals.	1 to 18
D GND	19, 21, 23, 25, 27, 29, 31, 33

Using RTSI as Outputs

RTSI <0..7> are bidirectional terminals. As an output, you can drive any of the following signals to any RTSI terminal:

- AI Start Trigger (ai/StartTrigger)
- AI Reference Trigger (ai/ReferenceTrigger)
- AI Convert Clock* (ai/ConvertClock)
- AI Sample Clock (ai/SampleClock)
- AI Pause Trigger (ai/PauseTrigger)
- AO Sample Clock* (ao/SampleClock)
- AO Start Trigger (ao/StartTrigger)
- AO Pause Trigger (ao/PauseTrigger)
- 10 MHz Reference Clock
- Counter *n* Source, Gate, Z, Internal Output
- Change Detection Event
- Analog Comparison Event
- FREQ OUT
- PFI <0..5>



Note Signals with a * are inverted before being driven on the RTSI terminals.

Using RTSI Terminals as Timing Input Signals

You can use RTSI terminals to route external timing signals to many different M Series functions. Each RTSI terminal can be routed to any of the following signals:

- AI Convert Clock (ai/ConvertClock)
- AI Sample Clock (ai/SampleClock)
- AI Start Trigger (ai/StartTrigger)
- AI Reference Trigger (ai/ReferenceTrigger)
- AI Pause Trigger (ai/PauseTrigger)
- AI Sample Clock Timebase (ai/SampleClockTimebase)
- AO Start Trigger (ao/StartTrigger)
- AO Sample Clock (ao/SampleClock)
- AO Sample Clock Timebase (ao/SampleClockTimebase)
- AO Pause Trigger (ao/PauseTrigger)
- Counter input signals for either counter—Source, Gate, Aux, HW_Arm, A, B, or Z
- DI Sample Clock (di/SampleClock)
- DO Sample Clock (do/SampleClock)

Most functions allow you to configure the polarity of PFI inputs and whether the input is edge or level sensitive.

RTSI Filters

You can enable a programmable debouncing filter on each PFI, RTSI, or PXI_STAR signal. When the filters are enabled, your device samples the input on each rising edge of a filter clock. M Series devices use an onboard oscillator to generate the filter clock with a 40 MHz frequency.



Note NI-DAQmx *only* supports filters on counter inputs.

The following is an example of low to high transitions of the input signal. High to low transitions work similarly.

Assume that an input terminal has been low for a long time. The input terminal then changes from low to high, but glitches several times. When the filter clock has sampled the signal high on N consecutive edges, the low to high transition is propagated to the rest of the circuit. The value of N depends on the filter setting; refer to Table 9-2.

Table 9-2. Filters

Filter Setting	N (Filter Clocks Needed to Pass Signal)	Pulse Width Guaranteed to Pass Filter	Pulse Width Guaranteed to Not Pass Filter
125 ns	5	125 ns	100 ns
6.425 μ s	257	6.425 μ s	6.400 μ s
2.56 ms	~101,800	2.56 ms	2.54 ms
Disabled	—	—	—

The filter setting for each input can be configured independently. On power up, the filters are disabled. Figure 9-3 shows an example of a low to high transition on an input that has its filter set to 125 ns ($N = 5$).

Figure 9-3. Filter Example

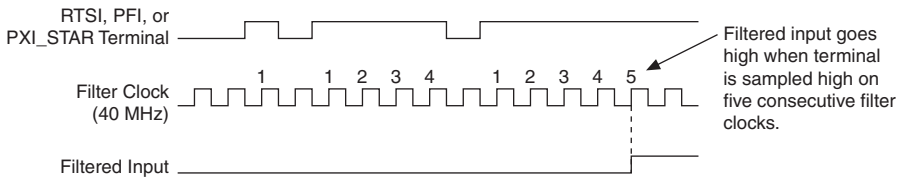

Enabling filters introduces jitter on the input signal. For the 125 ns and 6.425 μ s filter settings, the jitter is up to 25 ns. On the 2.56 ms setting, the jitter is up to 10.025 μ s.

When a PFI input is routed directly to RTSI, or a RTSI input is routed directly to PFI, the M Series device does not use the filtered version of the input signal.

Refer to the KnowledgeBase document, *Digital Filtering with M Series and CompactDAQ*, for more information about digital filters and counters. To access this KnowledgeBase, go to ni.com/info and enter the Info Code `rddfms`.

PXI Clock and Trigger Signals

PXI clock and trigger signals are only available on PXI/PXI Express devices.

PXI_CLK10

PXI_CLK10 is a common low-skew 10 MHz reference clock for synchronization of multiple modules in a PXI measurement or control system. The PXI backplane is responsible for generating PXI_CLK10 independently to each peripheral slot in a PXI chassis.

PXI Triggers

A PXI chassis provides eight bused trigger lines to each module in a system. Triggers may be passed from one module to another, allowing precisely timed responses to asynchronous external events that are being monitored or controlled. Triggers can be used to synchronize the operation of several different PXI peripheral modules.

On M Series devices, the eight PXI trigger signals are synonymous with RTSI <0..7>.

Note that in a PXI chassis with more than eight slots, the PXI trigger lines may be divided into multiple independent buses. Refer to the documentation for your chassis for details.

PXI_STAR Trigger

In a PXI system, the Star Trigger bus implements a dedicated trigger line between the first peripheral slot (adjacent to the system slot) and the other peripheral slots. The Star Trigger can be used to synchronize multiple devices or to share a common trigger signal among devices.

A Star Trigger controller can be installed in this first peripheral slot to provide trigger signals to other peripheral modules. Systems that do not require this functionality can install any standard peripheral module in this first peripheral slot.

An M Series device receives the Star Trigger signal (PXI_STAR) from a Star Trigger controller. PXI_STAR can be used as an external source for many AI, AO, and counter signals.

An M Series device is not a Star Trigger controller. An M Series device may be used in the first peripheral slot of a PXI system, but the system will not be able to use the Star Trigger feature.

PXI_STAR Filters

You can enable a programmable debouncing filter on each PFI, RTSI, or PXI_STAR signal. When the filters are enabled, your device samples the input on each rising edge of a filter clock. M Series devices use an onboard oscillator to generate the filter clock with a 40 MHz frequency.



Note NI-DAQmx *only* supports filters on counter inputs.

The following is an example of low to high transitions of the input signal. High to low transitions work similarly.

Assume that an input terminal has been low for a long time. The input terminal then changes from low to high, but glitches several times. When the filter clock has sampled the signal high on N consecutive edges, the low to high transition is propagated to the rest of the circuit. The value of N depends on the filter setting; refer to Table 9-3.

Table 9-3. Filters

Filter Setting	N (Filter Clocks Needed to Pass Signal)	Pulse Width Guaranteed to Pass Filter	Pulse Width Guaranteed to Not Pass Filter
125 ns	5	125 ns	100 ns
6.425 μ s	257	6.425 μ s	6.400 μ s
2.56 ms	~101,800	2.56 ms	2.54 ms
Disabled	—	—	—

The filter setting for each input can be configured independently. On power up, the filters are disabled. Figure 9-4 shows an example of a low to high transition on an input that has its filter set to 125 ns ($N = 5$).

Figure 9-4. Filter Example

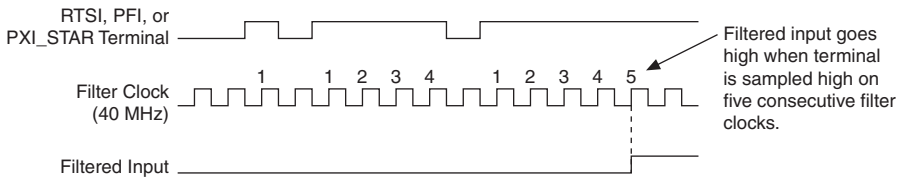

Enabling filters introduces jitter on the input signal. For the 125 ns and 6.425 μ s filter settings, the jitter is up to 25 ns. On the 2.56 ms setting, the jitter is up to 10.025 μ s.

When a PFI input is routed directly to RTSI, or a RTSI input is routed directly to PFI, the M Series device does not use the filtered version of the input signal.

Refer to the KnowledgeBase document, *Digital Filtering with M Series and CompactDAQ*, for more information about digital filters and counters. To access this KnowledgeBase, go to ni.com/info and enter the Info Code `rddfms`.

Bus Interface

The bus interface circuitry of M Series devices efficiently moves data between host memory and the measurement and acquisition circuits. M Series devices are available for the following platforms:

- PCI
- PCI Express
- PXI
- PXI Express
- USB

All M Series devices are jumperless for complete plug-and-play operation. The operating system automatically assigns the base address, interrupt levels, and other resources.

NI M Series PCI/PCIe/PXI/PXIe devices incorporate PCI-MITE technology to implement a high-performance PCI interface. M Series USB devices incorporate USB-STC2 technology to implement a Hi-Speed USB interface.

Data Transfer Methods

Refer to the following sections for information about bus interface data transfer methods for M Series devices.

PCI/PCI Express Device and PXI/PXI Express Module Data Transfer Methods

The primary ways to transfer data across the PCI bus are as follows:

- **Direct Memory Access (DMA)**—DMA is a method to transfer data between the device and computer memory without the involvement of the CPU. This method makes DMA the fastest available data transfer method. NI uses DMA hardware and software technology to achieve high throughput rates and increase system utilization. DMA is the default method of data transfer for PCI, PCI Express, PXI, and PXI Express devices and modules.

NI M Series PCI/PCIe/PXI/PXIe devices have six fully-independent DMA controllers for high-performance transfers of data blocks. One DMA controller is available for each measurement and acquisition block:

- Analog input
- Analog output
- Counter 0

- Counter 1
- Digital waveform generation (digital output)
- Digital waveform acquisition (digital input)

Each DMA controller channel contains a FIFO and independent processes for filling and emptying the FIFO. This allows the buses involved in the transfer to operate independently for maximum performance. Data is transferred simultaneously between the ports. The DMA controller supports burst transfers to and from the FIFO.

Each DMA controller supports several features to optimize PCI/PXI bus utilization. The DMA controllers pack and unpack data through the FIFOs. This feature allows the DMA controllers to combine multiple 16-bit transfers to the DAQ circuitry into a single 32-bit burst transfer on PCI. The DMA controllers also automatically handle unaligned memory buffers on PCI/PXI.

- **Interrupt Request (IRQ)**—IRQ transfers rely on the CPU to service data transfer requests. The device notifies the CPU when it is ready to transfer data. The data transfer speed is tightly coupled to the rate at which the CPU can service the interrupt requests. If you are using interrupts to transfer data at a rate faster than the rate the CPU can service the interrupts, your systems may start to freeze.
- **Programmed I/O**—Programmed I/O is a data transfer mechanism where the user's program is responsible for transferring data. Each read or write call in the program initiates the transfer of data. Programmed I/O is typically used in software-timed (on-demand) operations. Refer to the *Analog Output Data Generation Methods* section of Chapter 5, *Analog Output*, for more information.



Note On PCI, PCI Express, PXI, and PXI Express M Series devices, each measurement and acquisition circuit (that is, AI, AO, and so on) has a dedicated DMA channel. So in most applications, all data transfers use DMA. However, NI-DAQmx allows you to disable DMA and use interrupts. To change your data transfer mechanism between DMA and interrupts in NI-DAQmx, use the **Data Transfer Mechanism** property node.

USB Device Data Transfer Methods

The primary ways to transfer data across the PCI bus are as follows:

- **USB Signal Stream**—USB Signal Stream is a method to transfer data between the device and computer memory using USB bulk transfers without intervention of the microcontroller on the NI device. NI uses USB Signal Stream hardware and software technology to achieve high throughput rates and increase system utilization in USB devices.

M Series USB devices have four fully-independent USB Signal Stream for high-performance transfers of data blocks. These channels are assigned to the first four measurement/acquisition circuits that request one.

- **Programmed I/O**—Programmed I/O is a data transfer mechanism where the user's program is responsible for transferring data. Each read or write call in the program initiates the transfer of data. Programmed I/O is typically used in software-timed (on-demand) operations. Refer to the [Analog Output Data Generation Methods](#) section of Chapter 5, [Analog Output](#), for more information.



Note USB Signal Stream channels are assigned to the first four measurement/acquisition circuits that request one. When a USB Signal Stream is not available, you must set the data transfer mechanism to programmed I/O; otherwise the driver returns an error. To change your data transfer mechanism between USB Signal Stream and programmed I/O, use the **Data Transfer Mechanism** property node function in NI-DAQmx.

PXI Considerations

PXI clock and trigger signals are only available on PXI devices.

PXI Clock and Trigger Signals

Refer to the [PXI_CLK10](#), [PXI Triggers](#), [PXI_STAR Trigger](#), and [PXI_STAR Filters](#) sections of Chapter 9, [Digital Routing and Clock Generation](#), for more information about PXI clock and trigger signals.

PXI and PXI Express

NI PXI M Series devices can be installed in any PXI chassis and most slots of PXI Express hybrid chassis. NI PXI Express M Series devices can be installed in any PXI Express slot in PXI Express chassis.

PXI specifications are developed by the PXI System Alliance (www.pxisa.org). Using the terminology of the PXI specifications, some NI PXI M Series devices are 3U Hybrid Slot-Compatible PXI-1 Peripheral Modules. Refer to your device specifications to see if your PXI M Series device is hybrid slot-compatible.

3U designates devices that are 100 mm tall (as opposed to the taller 6U modules).

Hybrid slot-compatible defines where the device can be installed. PXI M Series devices can be installed in the following chassis and slots:

- **PXI chassis**—PXI M Series devices can be installed in any peripheral slot of a PXI chassis.
- **PXI Express chassis**¹—PXI M Series devices can be installed in the following PXI Express chassis slots:
 - PXI-1 slots—Accepts all PXI modules
 - PXI hybrid slots—Accepts PXI modules that are hybrid slot-compatible or PXI Express modules
 - PXI Express slots—Accepts PXI Express modules

PXI-1 devices use PCI signaling to communicate to the host controller (as opposed to PCI Express signaling).

Peripheral devices are installed in peripheral slots and are not system controllers.

Using PXI with CompactPCI

Using PXI-compatible products with standard CompactPCI products is an important feature provided by the *PXI Hardware Specification Revision 2.1*. If you use a PXI-compatible plug-in module in a standard CompactPCI chassis, you cannot use PXI-specific functions, but you can still use the basic plug-in device functions. For example, the RTSI bus on a PXI M Series device is available in a PXI chassis, but not in a CompactPCI chassis.

The CompactPCI specification permits vendors to develop sub-buses that coexist with the basic PCI interface on the CompactPCI bus. Compatible operation is not guaranteed between CompactPCI devices with different sub-buses nor between CompactPCI devices with sub-buses and PXI. The standard implementation for CompactPCI does not include these sub-buses. The PXI M Series device works in any standard CompactPCI chassis adhering to the *PICMG CompactPCI 2.0 R3.0* core specification.

PXI-specific features are implemented on the J2 connector of the CompactPCI bus. The PXI device is compatible with any CompactPCI chassis with a sub-bus that does not drive the lines used by that device. Even if the sub-bus is capable of driving these lines, the PXI device is still compatible as long as those terminals on the sub-bus are disabled by default and never enabled.



Caution Damage can result if these lines are driven by the sub-bus. NI is *not* liable for any damage resulting from improper signal connections.

¹ For some PXI M Series devices, there are two variants—one that will work in PXI hybrid slots and one that supports local bus for SCXI control when the device is in the right-most slot. Refer to the device specifications for more information.

Triggering

A trigger is a signal that causes an action, such as starting or stopping the acquisition of data. When you configure a trigger, you must decide how you want to produce the trigger and the action you want the trigger to cause. All M Series devices support internal software triggering, as well as external digital triggering. Some devices also support analog triggering. For information about the different actions triggers can perform for each sub-system of the device, refer to the following sections:

- The *Analog Input Triggering* section of Chapter 4, *Analog Input*
- The *Analog Output Triggering* section of Chapter 5, *Analog Output*
- The *Counter Triggering* section of Chapter 7, *Counters*



Note Not all M Series devices support analog triggering. For more information about triggering compatibility, refer to the specifications document for your device.

Triggering with a Digital Source

Your DAQ device can generate a trigger on a digital signal. You must specify a source and an edge. The digital source can be any of the PFI, RTSI, or PXI_STAR signals.

The edge can be either the rising edge or falling edge of the digital signal. A rising edge is a transition from a low logic level to a high logic level. A falling edge is a high to low transition.

Figure 11-1 shows a falling-edge trigger.

Figure 11-1. Falling-Edge Trigger

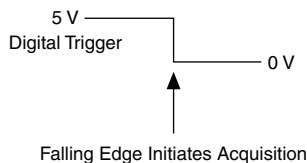

You also can program your DAQ device to perform an action in response to a trigger from a digital source. The action can affect the following:

- Analog input acquisition
- Analog output generation
- Counter behavior
- Digital waveform acquisition and generation

Triggering with an Analog Source

Some M Series devices can generate a trigger on an analog signal. To find your device triggering options, refer to the specifications document for your device.

Figure 11-2 shows the analog trigger circuit.

Figure 11-2. Analog Trigger Circuit

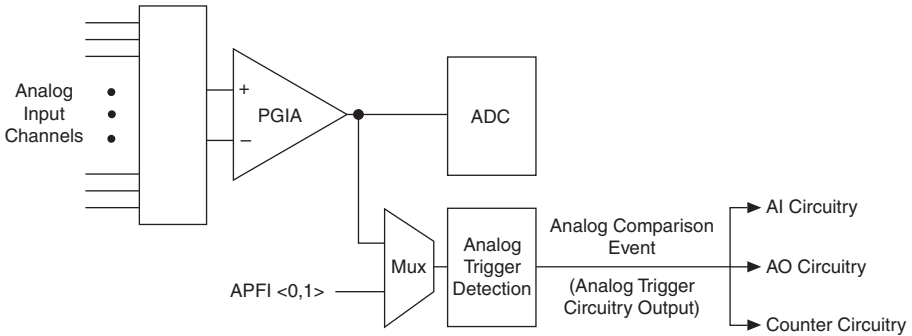

You must specify a source and an analog trigger type. The source can be either an APFI <0,1> terminal or an analog input channel.

APFI <0,1> Terminals

When you use either APFI <0,1> terminal as an analog trigger, you should drive the terminal with a low impedance signal source (less than 1 k Ω source impedance). If APFI <0,1> are left unconnected, they are susceptible to crosstalk from adjacent terminals, which can cause false triggering. Note that the APFI <0,1> terminals also can be used for other functions such as the AO External Reference input, as described in the [AO Offset and AO Reference Selection](#) section of Chapter 5, [Analog Output](#).

Analog Input Channels

Select any analog input channel to drive the NI-PGIA. The NI-PGIA amplifies the signal as determined by the input ground-reference setting and the input range. The output of the NI-PGIA then drives the analog trigger detection circuit. By using the NI-PGIA, you can trigger on very small voltage changes in the input signal.

When the DAQ device is waiting for an analog trigger with a AI channel as the source, the AI muxes should not route different AI channels to the NI-PGIA. If a different channel is routed to the NI-PGIA, the trigger condition on the desired channel could be missed. The other channels also could generate false triggers.

This behavior places some restrictions on using AI channels as trigger sources. When you use an analog start trigger, the trigger channel must be the first channel in the channel list. When you use an analog reference or pause trigger, and the analog channel is the source of the trigger, there can be only one channel in the channel list.

Analog Trigger Actions

The output of the analog trigger detection circuit is the Analog Comparison Event signal. You can program your DAQ device to perform an action in response to the Analog Comparison Event signal. The action can affect the following:

- Analog input acquisition
- Analog output generation
- Counter behavior

Routing Analog Comparison Event to an Output Terminal

You can route Analog Comparison Event out to any PFI <0..15> or RTSI <0..7> terminal.

Analog Trigger Types

Configure the analog trigger circuitry to different triggering modes:

- **Analog Edge Triggering**—Configure the analog trigger circuitry to detect when the analog signal is below or above a level you specify.

In below-level analog triggering mode, shown in Figure 11-3, the trigger is generated when the signal value is less than Level.

Figure 11-3. Below-Level Analog Triggering Mode

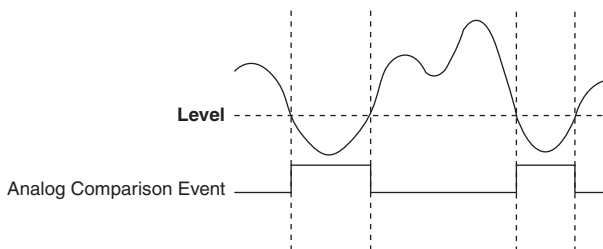

In above-level analog triggering mode, shown in Figure 11-4, the trigger is generated when the signal value is greater than Level.

Figure 11-4. Above-Level Analog Triggering Mode

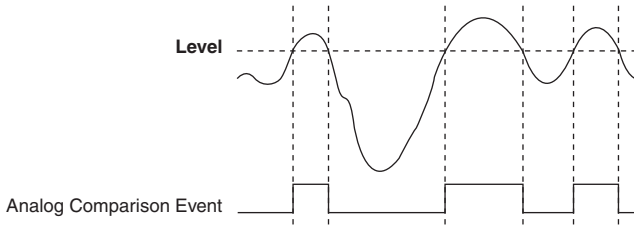

- **Analog Edge Triggering with Hysteresis**—Hysteresis adds a programmable voltage region above or below the trigger level that an input signal must pass through before the DAQ device recognizes a trigger condition, and is often used to reduce false triggering due to noise or jitter in the signal.
 - **Analog Edge Trigger with Hysteresis (Rising Slope)**—When using hysteresis with a rising slope, you specify a trigger level and amount of hysteresis. The high threshold is the trigger level; the low threshold is the trigger level minus the hysteresis. For the trigger to assert, the signal must first be below the low threshold, then go above the high threshold. The trigger stays asserted until the signal returns below the low threshold. The output of the trigger detection circuitry is the internal Analog Comparison Event signal, as shown in Figure 11-5.

Figure 11-5. Analog Edge Triggering with Hysteresis Rising Slope Example

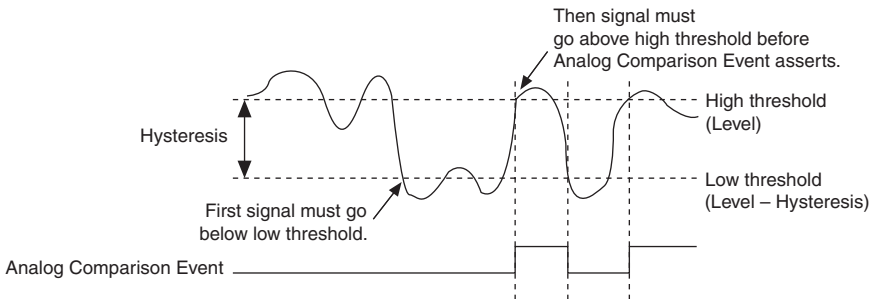

- **Analog Edge Trigger with Hysteresis (Falling Slope)**—When using hysteresis with a falling slope, you specify a trigger level and amount of hysteresis. The low threshold is the trigger level; the high threshold is the trigger level plus the hysteresis.

For the trigger to assert, the signal must first be above the high threshold, then go below the low threshold. The trigger stays asserted until the signal returns above the high threshold. The output of the trigger detection circuitry is the internal Analog Comparison Event signal, as shown in Figure 11-6.

Figure 11-6. Analog Edge Triggering with Hysteresis Falling Slope Example

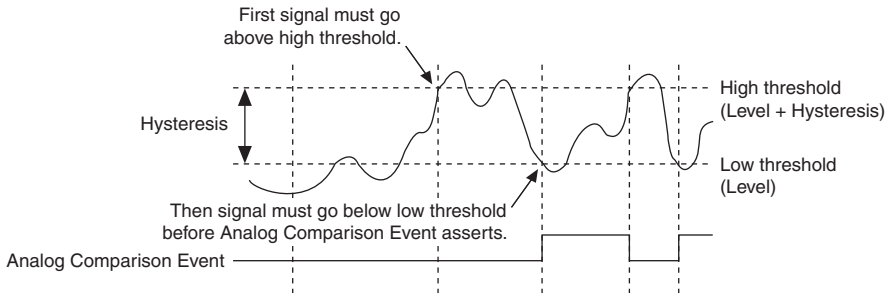

- **Analog Window Triggering**—An analog window trigger occurs when an analog signal either passes into (enters) or passes out of (leaves) a window defined by two voltage levels. Specify the levels by setting the window Top value and the window Bottom value.

Figure 11-7 demonstrates a trigger that asserts when the signal enters the window.

Figure 11-7. Analog Window Triggering Mode (Entering Window)

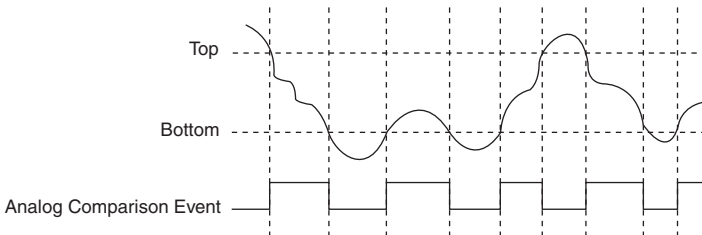

Analog Trigger Accuracy

The analog trigger circuitry compares the voltage of the trigger source to the output of programmable trigger DACs. When you configure the level (or the high and low limits in window trigger mode), the device adjusts the output of the trigger DACs. Refer to the specifications document for your device to find the accuracy or resolution of these DACs, which also shows the accuracy or resolution of analog triggers.

To improve accuracy, do the following:

- Use an AI channel (with a small input range) instead of APFI <0,1> as your trigger source. The DAQ device does not amplify the APFI <0,1> signals. When using an AI channel, the NI-PGIA amplifies the AI channel signal before driving the analog trigger circuitry. If you configure the AI channel to have a small input range, you can trigger on very small voltage changes in the input signal.
- Software-calibrate the analog trigger circuitry. The propagation delay from when a valid trigger condition is met to when the analog trigger circuitry emits the Analog Comparison Event may have an impact on your measurements if the trigger signal has a high slew rate. If you find these conditions have a noticeable impact on your measurements, you can perform software calibration on the analog trigger circuitry by configuring your task as normal and applying a known signal for your analog trigger. Comparing the observed results against the expected results, you can calculate the necessary offsets to apply in software to fine-tune the desired triggering behavior.

Module/Device-Specific Information

This appendix contains device pinouts, and information about specifications, cable and accessory choices, and other important topics for the following M Series modules/devices:

- [NI 6220](#)
- [NI 6221 \(68-Pin\)](#)
- [NI PCI-6221 \(37-Pin\)](#)
- [NI 6224](#)
- [NI 6225](#)
- [NI 6229](#)
- [NI 6250](#)
- [NI 6251](#)
- [NI 6254](#)
- [NI 6255](#)
- [NI 6259](#)
- [NI 6280](#)
- [NI 6281](#)
- [NI 6284](#)
- [NI 6289](#)

To obtain documentation for devices not listed here, refer to ni.com/manuals.



Note M Series devices may be used with most E Series accessories. However, some E Series accessories use different terminal names. Refer to Appendix D, [Upgrading from E Series to M Series](#), for more information.

NI 6220

PCI/PXI-6220 Pinout

Figure A-1 shows the pinout of the PCI/PXI-6220.

Figure A-1. PCI/PXI-6220 Pinout

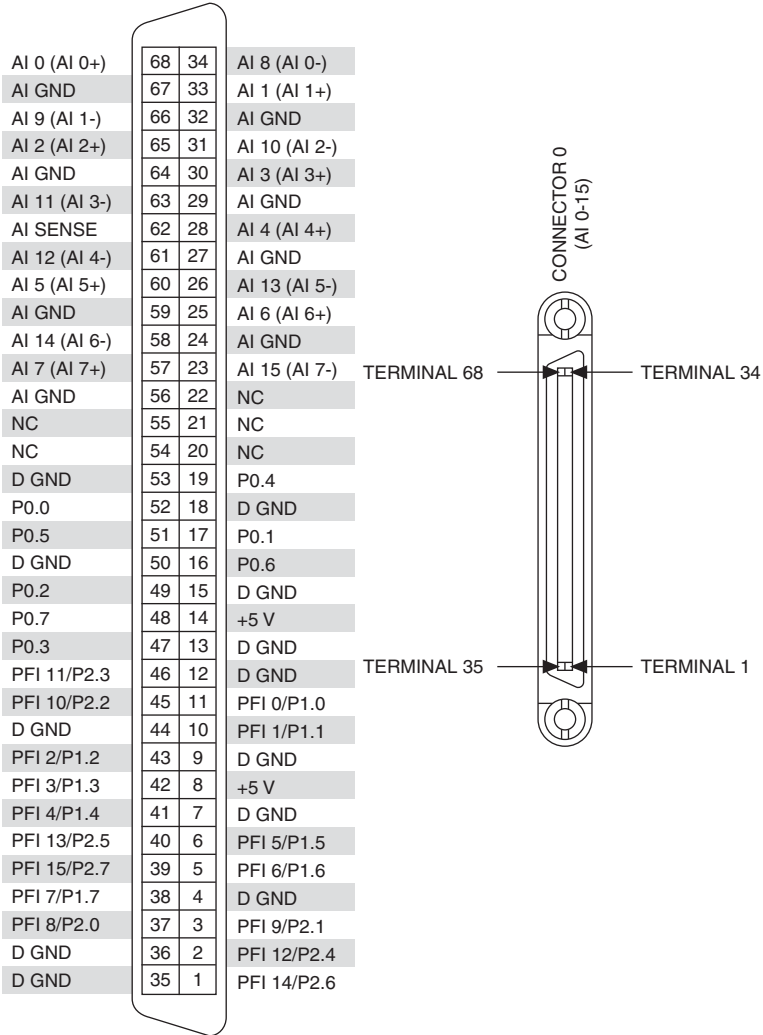

NC = No Connect

Table A-1. Default NI-DAQmx Counter/Timer Pins

Counter/Timer Signal	Default Pin Number (Name)
CTR 0 SRC	37 (PFI 8)
CTR 0 GATE	3 (PFI 9)
CTR 0 AUX	45 (PFI 10)
CTR 0 OUT	2 (PFI 12)
CTR 0 A	37 (PFI 8)
CTR 0 Z	3 (PFI 9)
CTR 0 B	45 (PFI 10)
CTR 1 SRC	42 (PFI 3)
CTR 1 GATE	41 (PFI 4)
CTR 1 AUX	46 (PFI 11)
CTR 1 OUT	40 (PFI 13)
CTR 1 A	42 (PFI 3)
CTR 1 Z	41 (PFI 4)
CTR 1 B	46 (PFI 11)
FREQ OUT	1 (PFI 14)



Note For a detailed description of each signal, refer to the *I/O Connector Signal Descriptions* section of Chapter 3, *Connector and LED Information*.



Note For more information about default NI-DAQmx counter inputs, refer to *Connecting Counter Signals* in the *NI-DAQmx Help* or the *LabVIEW Help*.

PCI/PXI-6220 Important Links

The following list contains links specific to your DAQ device:

- **Specifications**—Refer to the *NI 6220 Specifications* for more detailed information about the PCI/PXI-6220 device.
- **Accessory and Cabling Options**—Refer to the *68-Pin M Series Cables and Accessories* section of Chapter 2, *DAQ System Overview*, for more information.

NI 6221 (68-Pin)

The following sections contain information about the [PCI/PXI-6221](#), [USB-6221 Screw Terminal](#), and [USB-6221 BNC](#).

PCI/PXI-6221

PCI/PXI-6221 Pinout

Figure A-2 shows the pinout of the PCI/PXI-6221.

Figure A-2. PCI/PXI-6221 Pinout

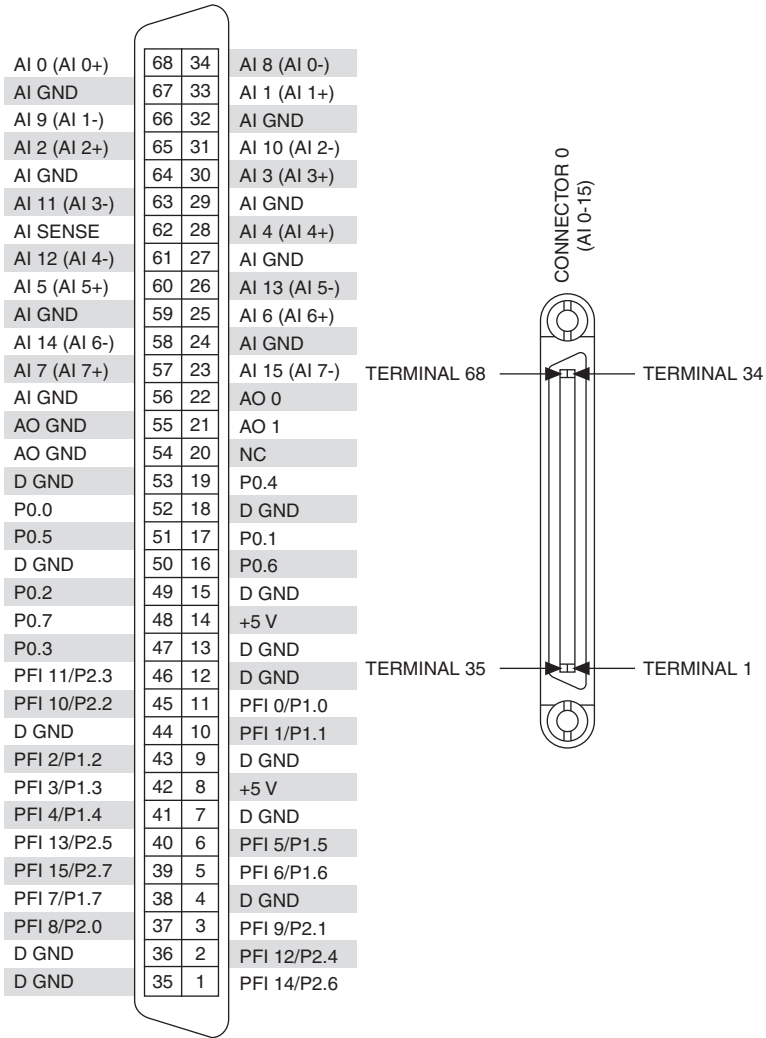

NC = No Connect

Table A-2. Default NI-DAQmx Counter/Timer Pins

Counter/Timer Signal	Default Pin Number (Name)
CTR 0 SRC	37 (PFI 8)
CTR 0 GATE	3 (PFI 9)
CTR 0 AUX	45 (PFI 10)
CTR 0 OUT	2 (PFI 12)
CTR 0 A	37 (PFI 8)
CTR 0 Z	3 (PFI 9)
CTR 0 B	45 (PFI 10)
CTR 1 SRC	42 (PFI 3)
CTR 1 GATE	41 (PFI 4)
CTR 1 AUX	46 (PFI 11)
CTR 1 OUT	40 (PFI 13)
CTR 1 A	42 (PFI 3)
CTR 1 Z	41 (PFI 4)
CTR 1 B	46 (PFI 11)
FREQ OUT	1 (PFI 14)



Note For a detailed description of each signal, refer to the *I/O Connector Signal Descriptions* section of Chapter 3, *Connector and LED Information*.



Note For more information about default NI-DAQmx counter inputs, refer to *Connecting Counter Signals* in the *NI-DAQmx Help* or the *LabVIEW Help*.

PCI/PXI-6221 Important Links

The following list contains links specific to your DAQ device:

- **Specifications**—Refer to the *NI 6221 Specifications* for more detailed information about the PCI/PXI-6221 device.
- **Accessory and Cabling Options**—Refer to the *68-Pin M Series Cables and Accessories* section of Chapter 2, *DAQ System Overview*, for more information.

USB-6221 Screw Terminal

USB-6221 Screw Terminal Pinout

Figure A-3 shows the pinout of the USB-6221 Screw Terminal.

Figure A-3. USB-6221 Screw Terminal Pinout

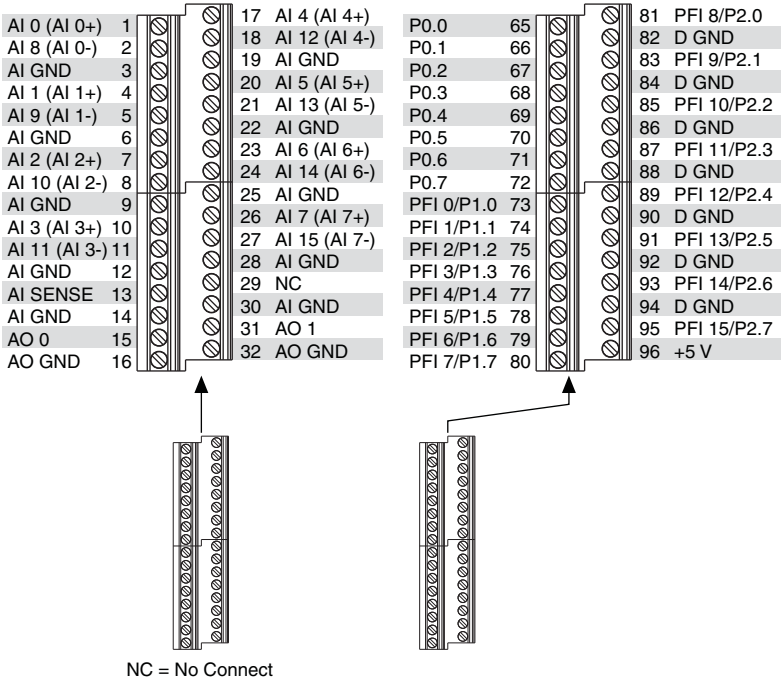

Table A-3. Default NI-DAQmx Counter/Timer Pins

Counter/Timer Signal	Default Pin Number (Name)
CTR 0 SRC	81 (PFI 8)
CTR 0 GATE	83 (PFI 9)
CTR 0 AUX	85 (PFI 10)
CTR 0 OUT	89 (PFI 12)
CTR 0 A	81 (PFI 8)
CTR 0 Z	83 (PFI 9)
CTR 0 B	85 (PFI 10)

Table A-3. Default NI-DAQmx Counter/Timer Pins (Continued)

Counter/Timer Signal	Default Pin Number (Name)
CTR 1 SRC	76 (PFI 3)
CTR 1 GATE	77 (PFI 4)
CTR 1 AUX	87 (PFI 11)
CTR 1 OUT	91 (PFI 13)
CTR 1 A	76 (PFI 3)
CTR 1 Z	77 (PFI 4)
CTR 1 B	87 (PFI 11)
FREQ OUT	93 (PFI 14)



Note For a detailed description of each signal, refer to the *I/O Connector Signal Descriptions* section of Chapter 3, *Connector and LED Information*.



Note For more information about default NI-DAQmx counter inputs, refer to *Connecting Counter Signals* in the *NI-DAQmx Help* or the *LabVIEW Help*.

USB-6221 Screw Terminal Important Links

The following list contains links specific to your DAQ device:

- **Specifications**—Refer to the *NI 6221 Specifications* for more detailed information about the USB-6221 Screw Terminal device.
- **LED Patterns**—Refer to the *LED Patterns* section of Chapter 3, *Connector and LED Information*, for information about the USB-6221 Screw Terminal LEDs.
- **Fuse Replacement**—Refer to the *USB Device Fuse Replacement* section of Chapter 1, *Getting Started*, for information about replacing the fuse on the USB-6221 Screw Terminal.
- **Accessory Options**—Refer to the *USB Device Accessories, USB Cable, and Power Supply* section of Chapter 2, *DAQ System Overview*, for more information.

USB-6221 BNC

USB-6221 BNC Pinout

Figure A-4 shows the pinout of the USB-6221 BNC.

Figure A-4. USB-6221 BNC Top Panel and Pinout

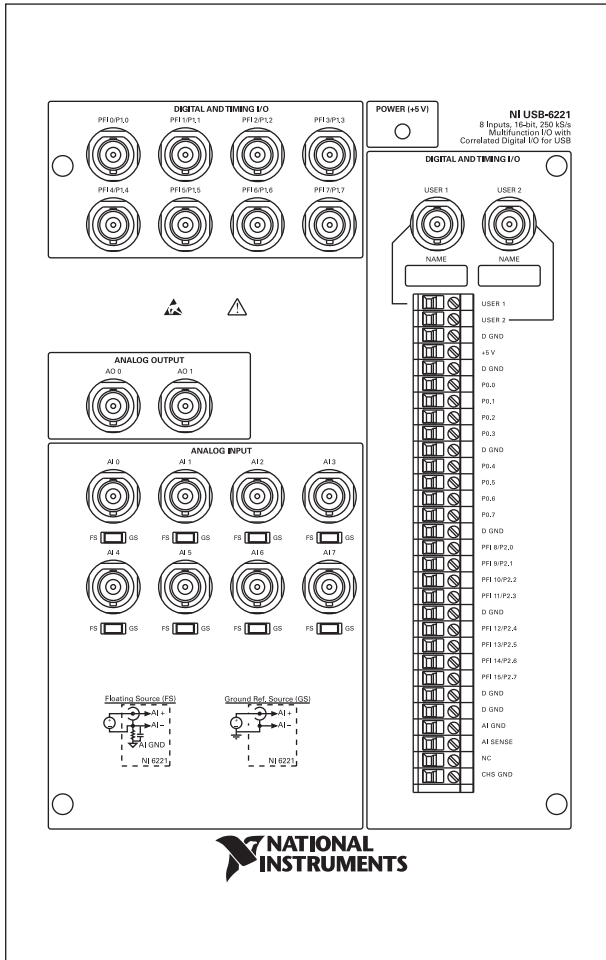

Table A-4. Default NI-DAQmx Counter/Timer Pins

Counter/Timer Signal	Default Pin Name
CTR 0 SRC	PFI 8
CTR 0 GATE	PFI 9
CTR 0 AUX	PFI 10
CTR 0 OUT	PFI 12
CTR 0 A	PFI 8
CTR 0 Z	PFI 9
CTR 0 B	PFI 10
CTR 1 SRC	PFI 3
CTR 1 GATE	PFI 4
CTR 1 AUX	PFI 11
CTR 1 OUT	PFI 13
CTR 1 A	PFI 3
CTR 1 Z	PFI 4
CTR 1 B	PFI 11
FREQ OUT	PFI 14



Note For a detailed description of each signal, refer to the *I/O Connector Signal Descriptions* section of Chapter 3, *Connector and LED Information*.



Note For more information about default NI-DAQmx counter inputs, refer to *Connecting Counter Signals* in the *NI-DAQmx Help* or the *LabVIEW Help*.

USB-6221 BNC Important Links

The following list contains links specific to your DAQ device:

- **Specifications**—Refer to the *NI 6221 Specifications* for more detailed information about the USB-6221 BNC device.
- **LED Patterns**—Refer to the *LED Patterns* section of Chapter 3, *Connector and LED Information*, for information about the USB-6221 BNC LEDs.
- **Fuse Replacement**—Refer to the *USB Device Fuse Replacement* section of Chapter 1, *Getting Started*, for information about replacing the fuse on the USB-6221 BNC.
- **Accessory Options**—Refer to the *USB Device Accessories, USB Cable, and Power Supply* section of Chapter 2, *DAQ System Overview*, for more information.

NI PCI-6221 (37-Pin)

PCI-6221 (37-Pin) Pinout

Figure A-5 shows the pinout of the PCI-6221 (37-pin).

Figure A-5. PCI-6221 (37-Pin) Pinout

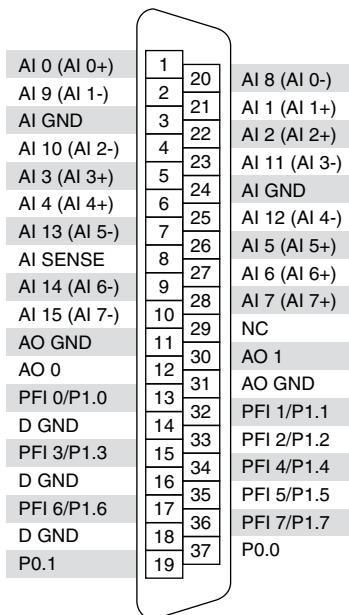

NC = No Connect

Table A-5. Default NI-DAQmx Counter/Timer Pins

Counter/Timer Signal	Default Pin Number (Name)
CTR 0 SRC	13 (PFI 0)
CTR 0 GATE	32 (PFI 1)
CTR 0 AUX	33 (PFI 2)
CTR 0 OUT	17 (PFI 6)
CTR 0 A	13 (PFI 0)
CTR 0 Z	32 (PFI 1)
CTR 0 B	33 (PFI 2)
CTR 1 SRC	15 (PFI 3)

Table A-5. Default NI-DAQmx Counter/Timer Pins (Continued)

Counter/Timer Signal	Default Pin Number (Name)
CTR 1 GATE	34 (PFI 4)
CTR 1 AUX	35 (PFI 5)
CTR 1 OUT	36 (PFI 7)
CTR 1 A	15 (PFI 3)
CTR 1 Z	34 (PFI 4)
CTR 1 B	35 (PFI 5)
FREQ OUT	35 (PFI 5)



Note For a detailed description of each signal, refer to the *I/O Connector Signal Descriptions* section of Chapter 3, *Connector and LED Information*.



Note For more information about default NI-DAQmx counter inputs, refer to *Connecting Counter Signals* in the *NI-DAQmx Help* or the *LabVIEW Help*.

PCI-6221 (37-Pin) Important Links

The following list contains links specific to your DAQ device:

- **Specifications**—Refer to the *NI 6221 (37-Pin) Specifications* for more detailed information about the PCI-6221 (37-pin) device.
- **Accessory and Cabling Options**—Refer to the *37-Pin M Series Cables and Accessories* section of Chapter 2, *DAQ System Overview*, for more information.

NI 6224

PCI/PXI-6224 Pinout

Figure A-6 shows the pinout of the PCI/PXI-6224. The I/O signals appear on two 68-pin connectors.

Figure A-6. PCI/PXI-6224 Pinout

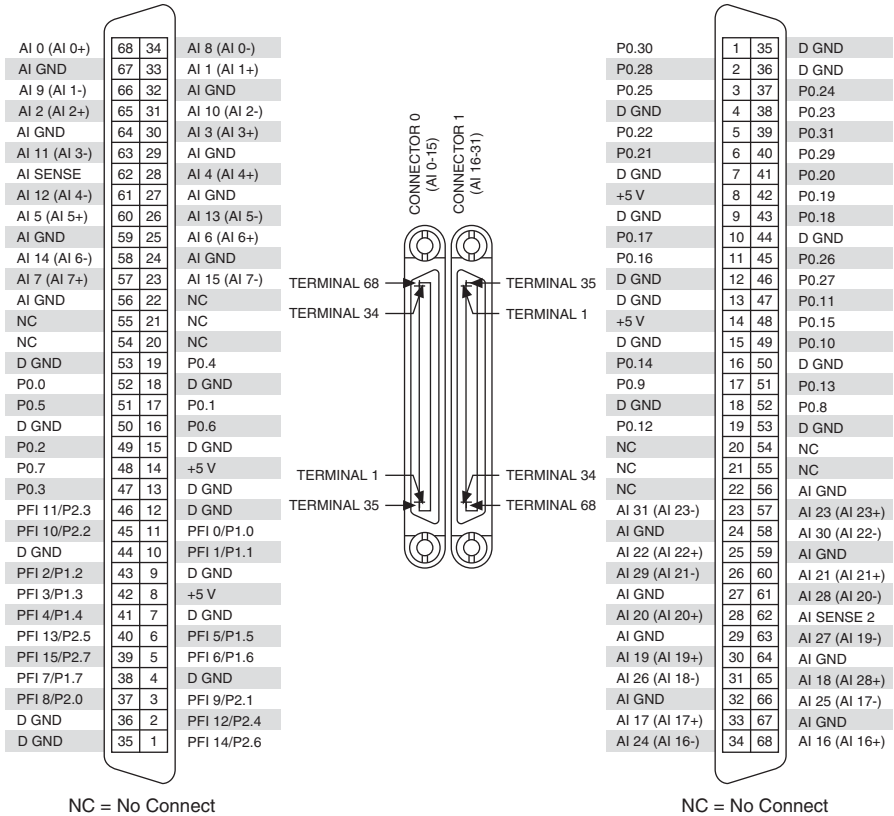

Table A-6. Default NI-DAQmx Counter/Timer Pins

Counter/Timer Signal	Default Connector 0 Pin Number (Name)
CTR 0 SRC	37 (PFI 8)
CTR 0 GATE	3 (PFI 9)
CTR 0 AUX	45 (PFI 10)
CTR 0 OUT	2 (PFI 12)
CTR 0 A	37 (PFI 8)
CTR 0 Z	3 (PFI 9)
CTR 0 B	45 (PFI 10)
CTR 1 SRC	42 (PFI 3)
CTR 1 GATE	41 (PFI 4)
CTR 1 AUX	46 (PFI 11)
CTR 1 OUT	40 (PFI 13)
CTR 1 A	42 (PFI 3)
CTR 1 Z	41 (PFI 4)
CTR 1 B	46 (PFI 11)
FREQ OUT	1 (PFI 14)



Note For a detailed description of each signal, refer to the *I/O Connector Signal Descriptions* section of Chapter 3, *Connector and LED Information*.



Note For more information about default NI-DAQmx counter inputs, refer to *Connecting Counter Signals* in the *NI-DAQmx Help* or the *LabVIEW Help*.

PCI/PXI-6224 Important Links

The following list contains links specific to your DAQ device:

- **Specifications**—Refer to the *NI 6224 Specifications* for more detailed information about the PCI/PXI-6224 device.
- **Accessory and Cabling Options**—Refer to the *68-Pin M Series Cables and Accessories* section of Chapter 2, *DAQ System Overview*, for more information.

NI 6225

The following sections contain information about the *PCI/PXI-6225*, *USB-6225 Screw Terminal*, and *USB-6225 Mass Termination*.

PCI/PXI-6225

PCI/PXI-6225 Pinout

Figure A-7 shows the pinout of the PCI/PXI-6225.

Figure A-7. PCI/PXI-6225 Pinout

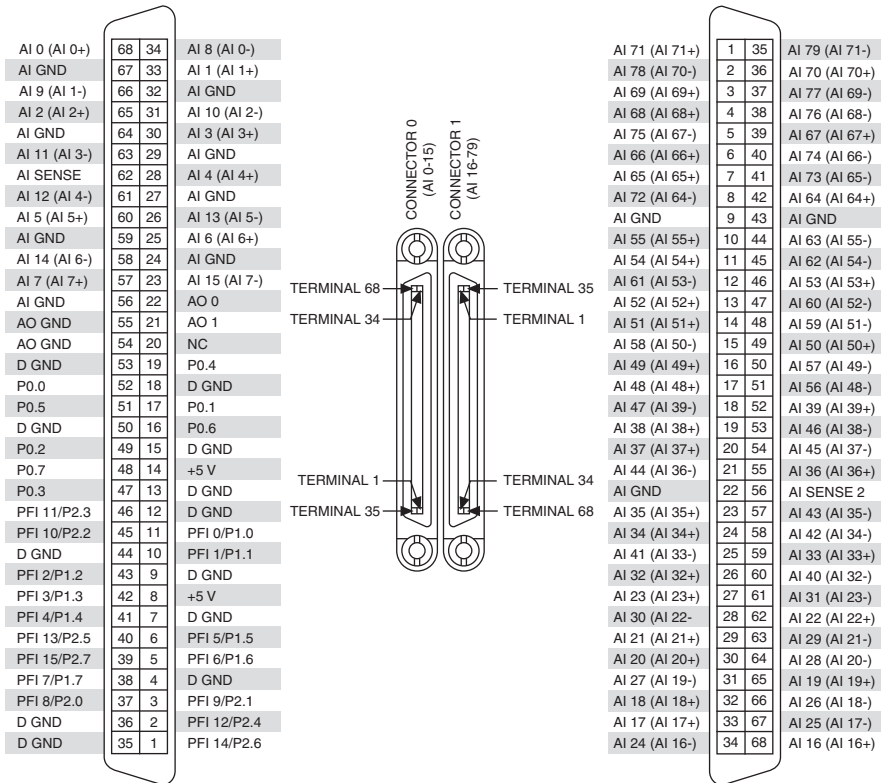

Table A-7. Default NI-DAQmx Counter/Timer Pins

Counter/Timer Signal	Default Connector 0 Pin Number (Name)
CTR 0 SRC	37 (PFI 8)
CTR 0 GATE	3 (PFI 9)
CTR 0 AUX	45 (PFI 10)
CTR 0 OUT	2 (PFI 12)
CTR 0 A	37 (PFI 8)
CTR 0 Z	3 (PFI 9)
CTR 0 B	45 (PFI 10)
CTR 1 SRC	42 (PFI 3)
CTR 1 GATE	41 (PFI 4)
CTR 1 AUX	46 (PFI 11)
CTR 1 OUT	40 (PFI 13)
CTR 1 A	42 (PFI 3)
CTR 1 Z	41 (PFI 4)
CTR 1 B	46 (PFI 11)
FREQ OUT	1 (PFI 14)



Note For a detailed description of each signal, refer to the *I/O Connector Signal Descriptions* section of Chapter 3, *Connector and LED Information*.



Note For more information about default NI-DAQmx counter inputs, refer to *Connecting Counter Signals* in the *NI-DAQmx Help* or the *LabVIEW Help*.

PCI/PXI-6225 Important Links

The following list contains links specific to your DAQ device:

- **Specifications**—Refer to the *NI 6225 Specifications* for more detailed information about the PCI/PXI-6225 device.
- **Accessory and Cabling Options**—Refer to the *68-Pin M Series Cables and Accessories* section of Chapter 2, *DAQ System Overview*, for more information.

USB-6225 Screw Terminal

USB-6225 Screw Terminal Pinout

Figure A-8 shows the pinout of the USB-6225 Screw Terminal.

Figure A-8. USB-6225 Screw Terminal Pinout

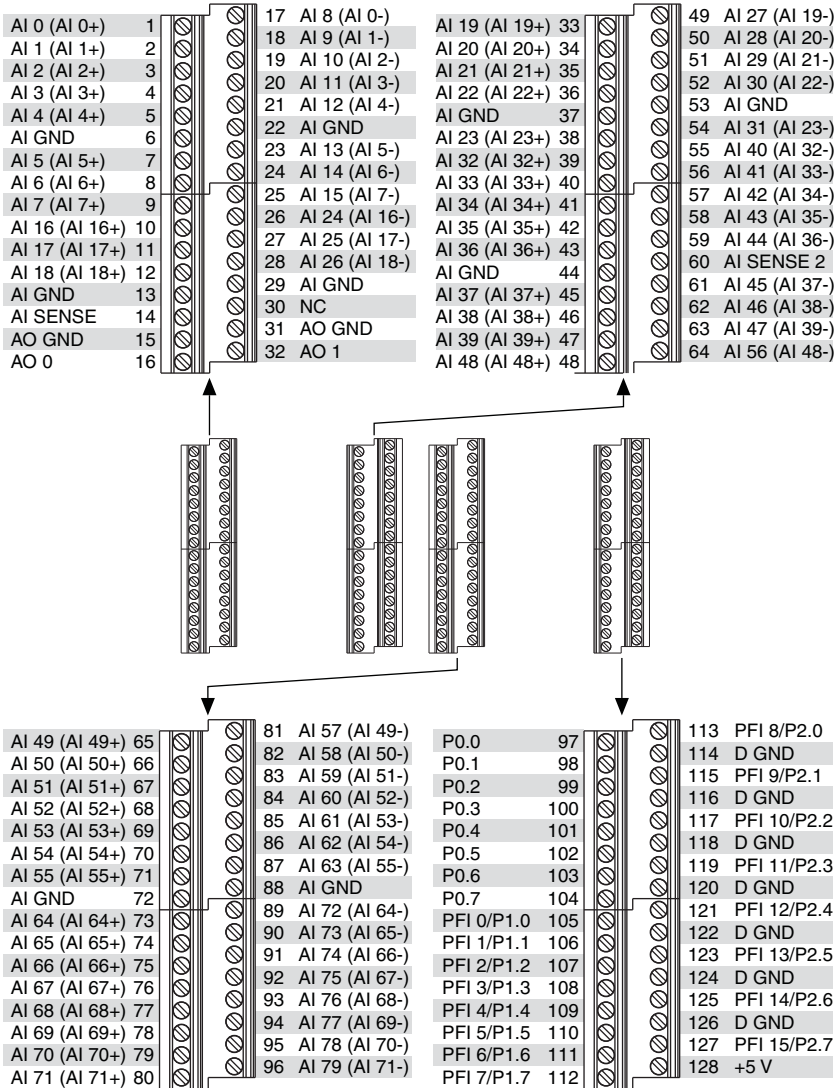

NC = No Connect

Table A-8. Default NI-DAQmx Counter/Timer Pins

Counter/Timer Signal	Default Pin Number (Name)
CTR 0 SRC	113 (PFI 8)
CTR 0 GATE	115 (PFI 9)
CTR 0 AUX	117 (PFI 10)
CTR 0 OUT	121 (PFI 12)
CTR 0 A	113 (PFI 8)
CTR 0 Z	115 (PFI 9)
CTR 0 B	117 (PFI 10)
CTR 1 SRC	108 (PFI 3)
CTR 1 GATE	109 (PFI 4)
CTR 1 AUX	119 (PFI 11)
CTR 1 OUT	123 (PFI 13)
CTR 1 A	108 (PFI 3)
CTR 1 Z	109 (PFI 4)
CTR 1 B	119 (PFI 11)
FREQ OUT	125 (PFI 14)



Note For a detailed description of each signal, refer to the *I/O Connector Signal Descriptions* section of Chapter 3, *Connector and LED Information*.



Note For more information about default NI-DAQmx counter inputs, refer to *Connecting Counter Signals* in the *NI-DAQmx Help* or the *LabVIEW Help*.

USB-6225 Screw Terminal Important Links

The following list contains links specific to your DAQ device:

- **Specifications**—Refer to the *NI 6225 Specifications* for more detailed information about the USB-6225 Screw Terminal device.
- **LED Patterns**—Refer to the *LED Patterns* section of Chapter 3, *Connector and LED Information*, for information about the USB-6225 Screw Terminal LEDs.
- **Fuse Replacement**—Refer to the *USB Device Fuse Replacement* section of Chapter 1, *Getting Started*, for information about replacing the fuse on the USB-6225 Screw Terminal.
- **Accessory Options**—Refer to the *USB Device Accessories, USB Cable, and Power Supply* section of Chapter 2, *DAQ System Overview*, for more information.

USB-6225 Mass Termination

USB-6225 Mass Termination Pinout

Figure A-9 shows the pinout of the USB-6225 Mass Termination device.

Figure A-9. USB-6225 Mass Termination Pinout

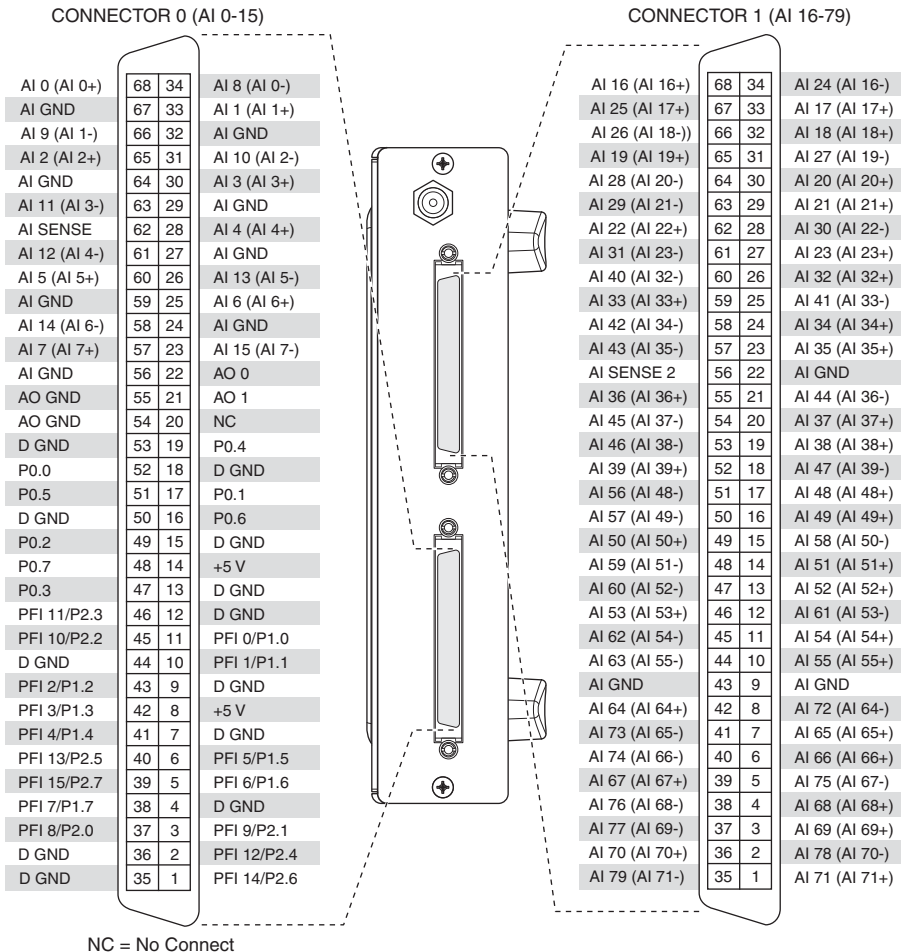

Table A-9. Default NI-DAQmx Counter/Timer Pins

Counter/Timer Signal	Default Connector 0 Pin Number (Name)
CTR 0 SRC	37 (PFI 8)
CTR 0 GATE	3 (PFI 9)

Table A-9. Default NI-DAQmx Counter/Timer Pins (Continued)

Counter/Timer Signal	Default Connector 0 Pin Number (Name)
CTR 0 AUX	45 (PFI 10)
CTR 0 OUT	2 (PFI 12)
CTR 0 A	37 (PFI 8)
CTR 0 Z	3 (PFI 9)
CTR 0 B	45 (PFI 10)
CTR 1 SRC	42 (PFI 3)
CTR 1 GATE	41 (PFI 4)
CTR 1 AUX	46 (PFI 11)
CTR 1 OUT	40 (PFI 13)
CTR 1 A	42 (PFI 3)
CTR 1 Z	41 (PFI 4)
CTR 1 B	46 (PFI 11)
FREQ OUT	1 (PFI 14)



Note For a detailed description of each signal, refer to the *I/O Connector Signal Descriptions* section of Chapter 3, *Connector and LED Information*.



Note For more information about default NI-DAQmx counter inputs, refer to *Connecting Counter Signals* in the *NI-DAQmx Help* or the *LabVIEW Help*.

USB-6225 Mass Termination Important Links

The following list contains links specific to your DAQ device:

- **Specifications**—Refer to the *NI 6225 Specifications* for more detailed information about the USB-6225 Mass Termination device.
- **LED Patterns**—Refer to the *LED Patterns* section of Chapter 3, *Connector and LED Information*, for information about the USB-6225 Mass Termination LEDs.
- **Fuse Replacement**—Refer to the *USB Device Fuse Replacement* section of Chapter 1, *Getting Started*, for information about replacing the fuse on the USB-6225 Mass Termination.
- **Accessory and Cabling Options**—Refer to the *68-Pin M Series Cables and Accessories* section of Chapter 2, *DAQ System Overview*, for more information.

NI 6229

The following sections contain information about the [PCI/PXI-6229](#), [USB-6229 Screw Terminal](#), and [USB-6229 BNC](#).

PCI/PXI-6229

PCI/PXI-6229 Pinout

Figure A-10 shows the pinout of the PCI/PXI-6229. The I/O signals appear on two 68-pin connectors.

Figure A-10. PCI/PXI-6229 Pinout

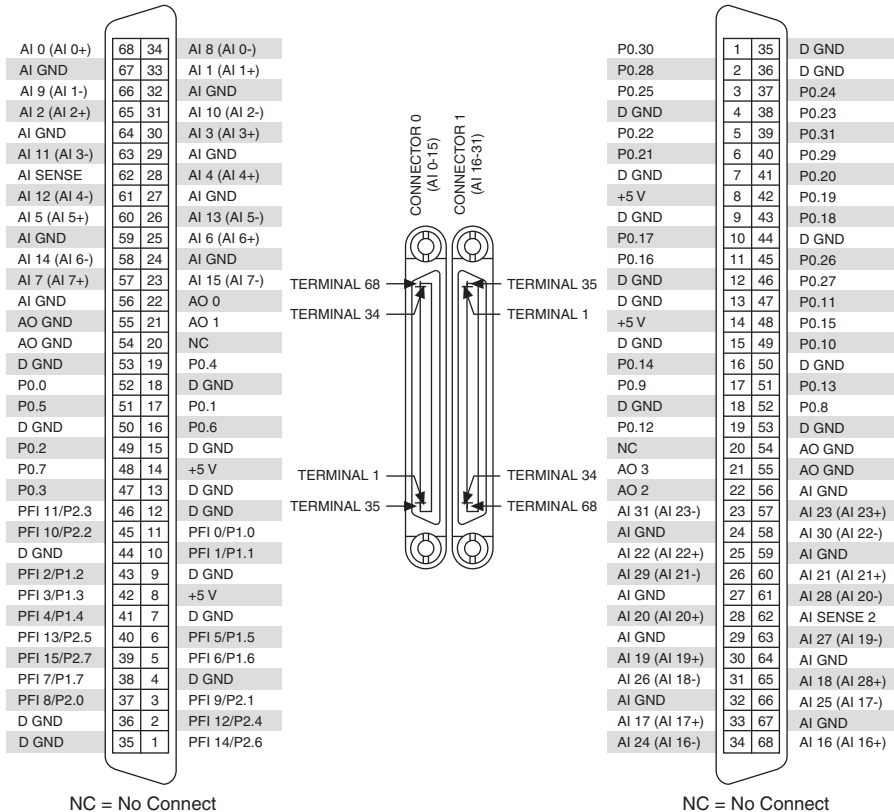

Table A-10. Default NI-DAQmx Counter/Timer Pins

Counter/Timer Signal	Default Connector 0 Pin Number (Name)
CTR 0 SRC	37 (PFI 8)
CTR 0 GATE	3 (PFI 9)
CTR 0 AUX	45 (PFI 10)
CTR 0 OUT	2 (PFI 12)
CTR 0 A	37 (PFI 8)
CTR 0 Z	3 (PFI 9)
CTR 0 B	45 (PFI 10)
CTR 1 SRC	42 (PFI 3)
CTR 1 GATE	41 (PFI 4)
CTR 1 AUX	46 (PFI 11)
CTR 1 OUT	40 (PFI 13)
CTR 1 A	42 (PFI 3)
CTR 1 Z	41 (PFI 4)
CTR 1 B	46 (PFI 11)
FREQ OUT	1 (PFI 14)



Note For a detailed description of each signal, refer to the *I/O Connector Signal Descriptions* section of Chapter 3, *Connector and LED Information*.



Note For more information about default NI-DAQmx counter inputs, refer to *Connecting Counter Signals* in the *NI-DAQmx Help* or the *LabVIEW Help*.

PCI/PXI-6229 Important Links

The following list contains links specific to your DAQ device:

- **Specifications**—Refer to the *NI 6229 Specifications* for more detailed information about the PCI/PXI-6229 device.
- **Accessory and Cabling Options**—Refer to the *68-Pin M Series Cables and Accessories* section of Chapter 2, *DAQ System Overview*, for more information.

USB-6229 Screw Terminal

USB-6229 Screw Terminal Pinout

Figure A-11 shows the pinout of the USB-6229 Screw Terminal.

Figure A-11. USB-6229 Screw Terminal Pinout

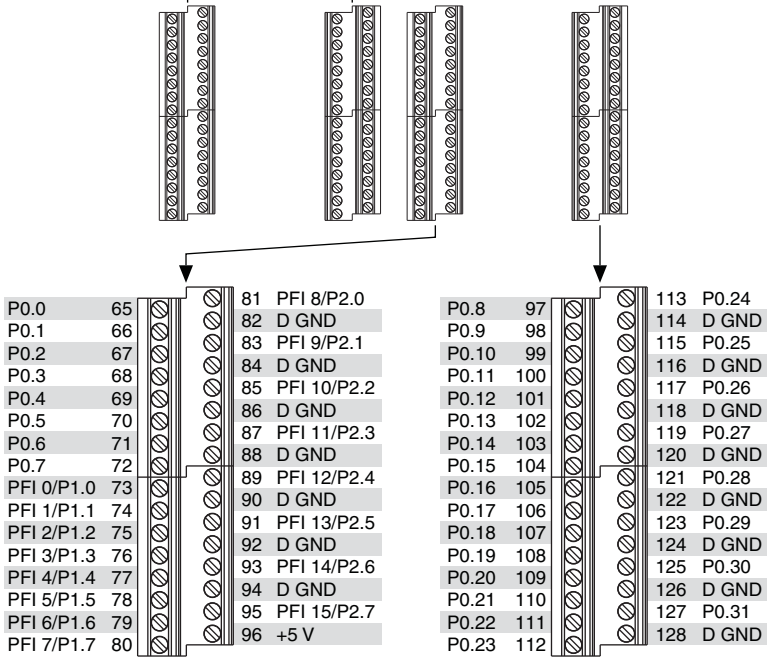
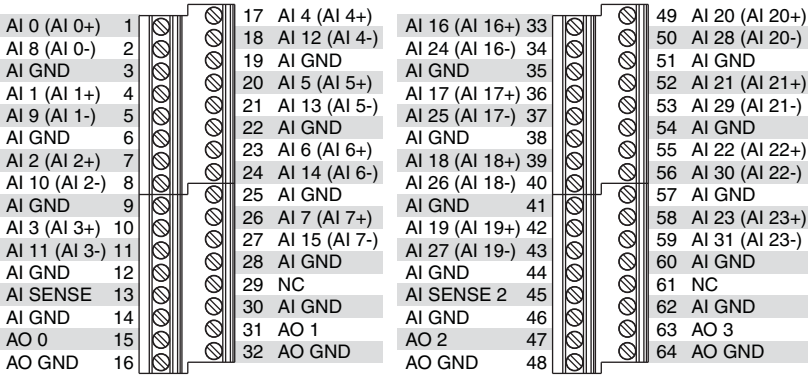

NC = No Connect

NC = No Connect

Table A-11. Default NI-DAQmx Counter/Timer Pins

Counter/Timer Signal	Default Pin Number (Name)
CTR 0 SRC	81 (PFI 8)
CTR 0 GATE	83 (PFI 9)
CTR 0 AUX	85 (PFI 10)
CTR 0 OUT	89 (PFI 12)
CTR 0 A	81 (PFI 8)
CTR 0 Z	83 (PFI 9)
CTR 0 B	85 (PFI 10)
CTR 1 SRC	76 (PFI 3)
CTR 1 GATE	77 (PFI 4)
CTR 1 AUX	87 (PFI 11)
CTR 1 OUT	91 (PFI 13)
CTR 1 A	76 (PFI 3)
CTR 1 Z	77 (PFI 4)
CTR 1 B	87 (PFI 11)
FREQ OUT	93 (PFI 14)



Note For a detailed description of each signal, refer to the *I/O Connector Signal Descriptions* section of Chapter 3, *Connector and LED Information*.



Note For more information about default NI-DAQmx counter inputs, refer to *Connecting Counter Signals* in the *NI-DAQmx Help* or the *LabVIEW Help*.

USB-6229 Screw Terminal Important Links

The following list contains links specific to your DAQ device:

- **Specifications**—Refer to the *NI 6229 Specifications* for more detailed information about the USB-6229 Screw Terminal device.
- **LED Patterns**—Refer to the *LED Patterns* section of Chapter 3, *Connector and LED Information*, for information about the USB-6229 Screw Terminal LEDs.
- **Fuse Replacement**—Refer to the *USB Device Fuse Replacement* section of Chapter 1, *Getting Started*, for information about replacing the fuse on the USB-6229 Screw Terminal.
- **Accessory Options**—Refer to the *USB Device Accessories, USB Cable, and Power Supply* section of Chapter 2, *DAQ System Overview*, for more information.

USB-6229 BNC

USB-6229 BNC Pinout

Figure A-12 shows the pinout of the USB-6229 BNC.

Figure A-12. USB-6229 BNC Top Panel and Pinout

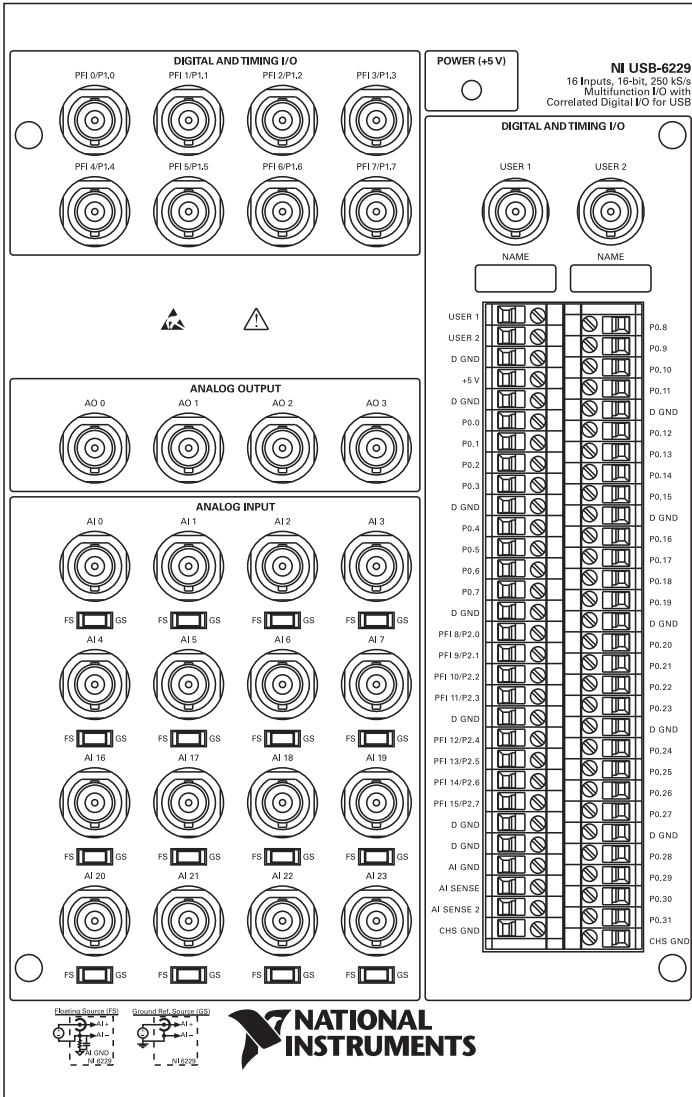

Table A-12. Default NI-DAQmx Counter/Timer Pins

Counter/Timer Signal	Default Pin Name
CTR 0 SRC	PFI 8
CTR 0 GATE	PFI 9
CTR 0 AUX	PFI 10
CTR 0 OUT	PFI 12
CTR 0 A	PFI 8
CTR 0 Z	PFI 9
CTR 0 B	PFI 10
CTR 1 SRC	PFI 3
CTR 1 GATE	PFI 4
CTR 1 AUX	PFI 11
CTR 1 OUT	PFI 13
CTR 1 A	PFI 3
CTR 1 Z	PFI 4
CTR 1 B	PFI 11
FREQ OUT	PFI 14



Note For a detailed description of each signal, refer to the *I/O Connector Signal Descriptions* section of Chapter 3, *Connector and LED Information*.



Note For more information about default NI-DAQmx counter inputs, refer to *Connecting Counter Signals* in the *NI-DAQmx Help* or the *LabVIEW Help*.

USB-6229 BNC Important Links

The following list contains links specific to your DAQ device:

- **Specifications**—Refer to the *NI 6229 Specifications* for more detailed information about the USB-6229 BNC device.
- **LED Patterns**—Refer to the *LED Patterns* section of Chapter 3, *Connector and LED Information*, for information about the USB-6229 BNC LEDs.
- **Fuse Replacement**—Refer to the *USB Device Fuse Replacement* section of Chapter 1, *Getting Started*, for information about replacing the fuse on the USB-6229 BNC.
- **Accessory Options**—Refer to the *USB Device Accessories, USB Cable, and Power Supply* section of Chapter 2, *DAQ System Overview*, for more information.

NI 6250

PCI/PXI-6250 Pinout

Figure A-13 shows the pinout of the PCI/PXI-6250.

Figure A-13. PCI/PXI-6250 Pinout

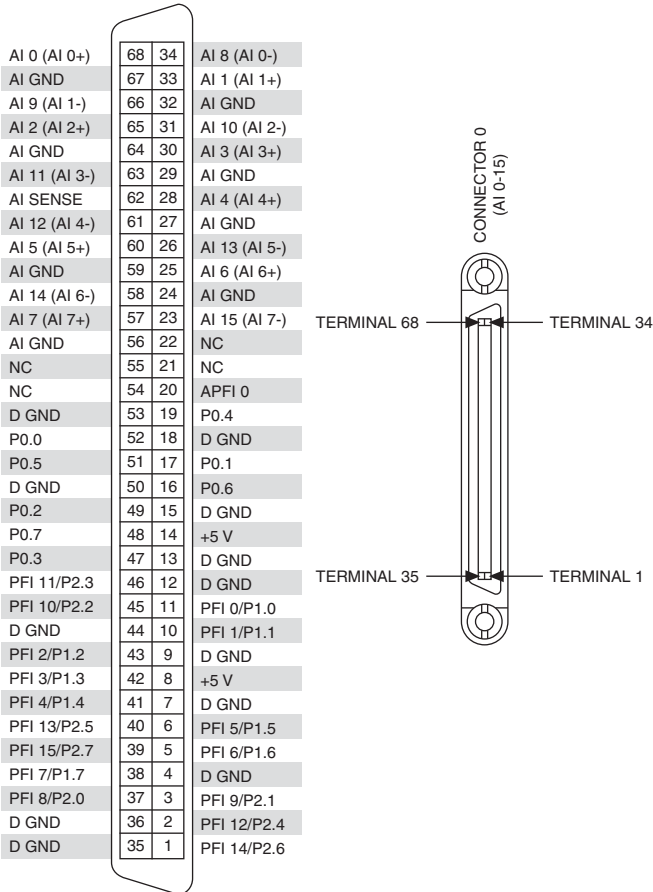

NC = No Connect

Table A-13. Default NI-DAQmx Counter/Timer Pins

Counter/Timer Signal	Default Pin Number (Name)
CTR 0 SRC	37 (PFI 8)
CTR 0 GATE	3 (PFI 9)
CTR 0 AUX	45 (PFI 10)
CTR 0 OUT	2 (PFI 12)
CTR 0 A	37 (PFI 8)
CTR 0 Z	3 (PFI 9)
CTR 0 B	45 (PFI 10)
CTR 1 SRC	42 (PFI 3)
CTR 1 GATE	41 (PFI 4)
CTR 1 AUX	46 (PFI 11)
CTR 1 OUT	40 (PFI 13)
CTR 1 A	42 (PFI 3)
CTR 1 Z	41 (PFI 4)
CTR 1 B	46 (PFI 11)
FREQ OUT	1 (PFI 14)



Note For a detailed description of each signal, refer to the *I/O Connector Signal Descriptions* section of Chapter 3, *Connector and LED Information*.



Note For more information about default NI-DAQmx counter inputs, refer to *Connecting Counter Signals* in the *NI-DAQmx Help* or the *LabVIEW Help*.

PCI/PXI-6250 Important Links

The following list contains links specific to your DAQ device:

- **Specifications**—Refer to the *NI 6250 Specifications* for more detailed information about the PCI/PXI-6250 device.
- **Accessory and Cabling Options**—Refer to the *68-Pin M Series Cables and Accessories* section of Chapter 2, *DAQ System Overview*, for more information.

NI 6251

The following sections contain information about the *NI PCI/PCle/PXI/PXIe-6251*, *USB-6251 Screw Terminal*, *USB-6251 BNC*, and *USB-6251 Mass Termination*.

NI PCI/PCle/PXI/PXIe-6251

NI PCI/PCle/PXI/PXIe-6251 Pinout

Figure A-14 shows the pinout of the NI PCI/PCle/PXI/PXIe-6251.

Figure A-14. NI PCI/PCle/PXI/PXIe-6251 Pinout

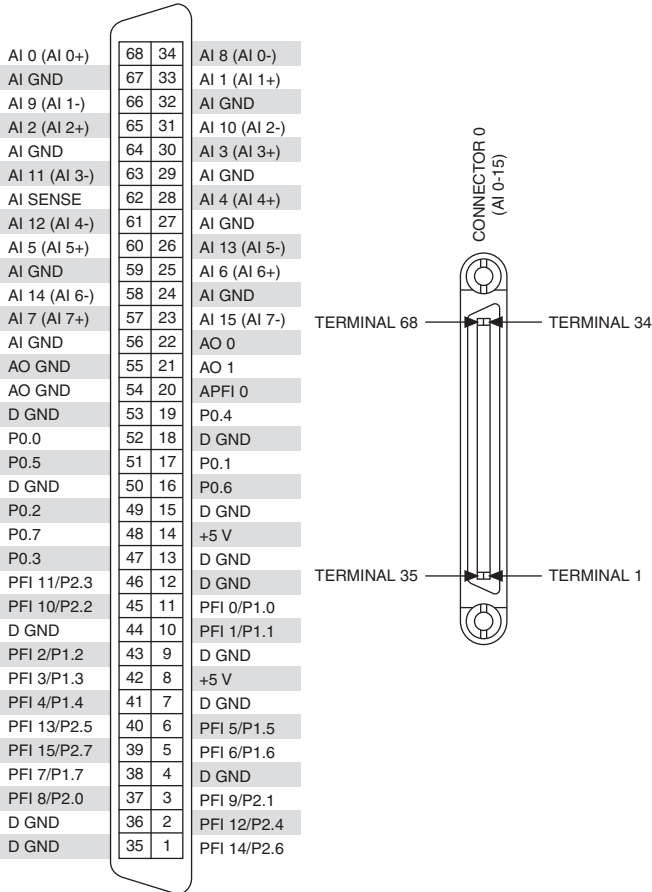

Table A-14. Default NI-DAQmx Counter/Timer Pins

Counter/Timer Signal	Default Pin Number (Name)
CTR 0 SRC	37 (PFI 8)
CTR 0 GATE	3 (PFI 9)
CTR 0 AUX	45 (PFI 10)
CTR 0 OUT	2 (PFI 12)
CTR 0 A	37 (PFI 8)
CTR 0 Z	3 (PFI 9)
CTR 0 B	45 (PFI 10)
CTR 1 SRC	42 (PFI 3)
CTR 1 GATE	41 (PFI 4)
CTR 1 AUX	46 (PFI 11)
CTR 1 OUT	40 (PFI 13)
CTR 1 A	42 (PFI 3)
CTR 1 Z	41 (PFI 4)
CTR 1 B	46 (PFI 11)
FREQ OUT	1 (PFI 14)



Note For a detailed description of each signal, refer to the *I/O Connector Signal Descriptions* section of Chapter 3, *Connector and LED Information*.



Note For more information about default NI-DAQmx counter inputs, refer to *Connecting Counter Signals* in the *NI-DAQmx Help* or the *LabVIEW Help*.

NI PCI/PCIe/PXI/PXIe-6251 Important Links

The following list contains links specific to your DAQ device:

- **Specifications**—Refer to the *NI 6251 Specifications* for more detailed information about the NI PCI/PCIe/PXI/PXIe-6251 device.
- **Accessory and Cabling Options**—Refer to the *68-Pin M Series Cables and Accessories* section of Chapter 2, *DAQ System Overview*, for more information.
- **PCI Express Disk Drive Power Connector**—Refer to the *RTSI Connector Pinout* section of Chapter 3, *Connector and LED Information*, for more information.

USB-6251 Screw Terminal

USB-6251 Screw Terminal Pinout

Figure A-15 shows the pinout of the USB-6251 Screw Terminal.

Figure A-15. USB-6251 Screw Terminal Pinout

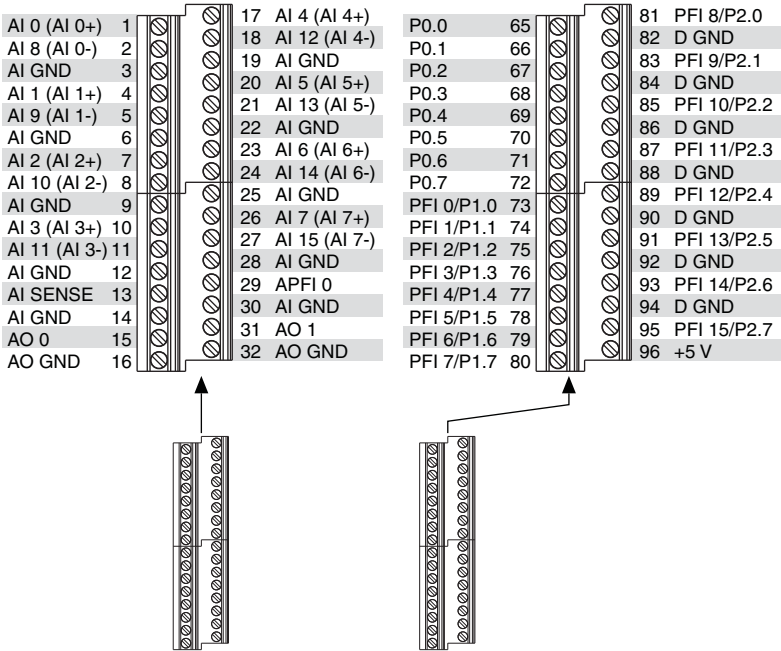

Table A-15. Default NI-DAQmx Counter/Timer Pins

Counter/Timer Signal	Default Pin Number (Name)
CTR 0 SRC	81 (PFI 8)
CTR 0 GATE	83 (PFI 9)
CTR 0 AUX	85 (PFI 10)
CTR 0 OUT	89 (PFI 12)
CTR 0 A	81 (PFI 8)
CTR 0 Z	83 (PFI 9)
CTR 0 B	85 (PFI 10)
CTR 1 SRC	76 (PFI 3)

Table A-15. Default NI-DAQmx Counter/Timer Pins (Continued)

Counter/Timer Signal	Default Pin Number (Name)
CTR 1 GATE	77 (PFI 4)
CTR 1 AUX	87 (PFI 11)
CTR 1 OUT	91 (PFI 13)
CTR 1 A	76 (PFI 3)
CTR 1 Z	77 (PFI 4)
CTR 1 B	87 (PFI 11)
FREQ OUT	93 (PFI 14)



Note For a detailed description of each signal, refer to the *I/O Connector Signal Descriptions* section of Chapter 3, *Connector and LED Information*.



Note For more information about default NI-DAQmx counter inputs, refer to *Connecting Counter Signals* in the *NI-DAQmx Help* or the *LabVIEW Help*.

USB-6251 Screw Terminal Important Links

The following list contains links specific to your DAQ device:

- **Specifications**—Refer to the *NI 625x Specifications* for more detailed information about the USB-6251 Screw Terminal device.
- **LED Patterns**—Refer to the *LED Patterns* section of Chapter 3, *Connector and LED Information*, for information about the USB-6251 Screw Terminal LEDs.
- **Fuse Replacement**—Refer to the *USB Device Fuse Replacement* section of Chapter 1, *Getting Started*, for information about replacing the fuse on the USB-6229 Screw Terminal.
- **Accessory Options**—Refer to the *USB Device Accessories, USB Cable, and Power Supply* section of Chapter 2, *DAQ System Overview*, for more information.

USB-6251 BNC

USB-6251 BNC Pinout

Figure A-16 shows the pinout of the USB-6251 BNC.

Figure A-16. USB-6251 BNC Top Panel and Pinout

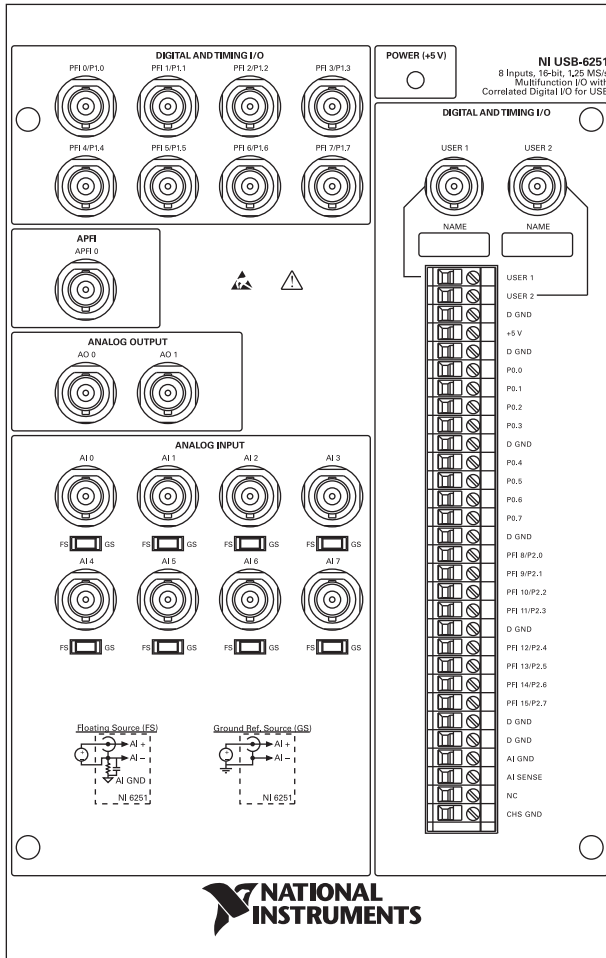

Table A-16. Default NI-DAQmx Counter/Timer Pins

Counter/Timer Signal	Default Pin Name
CTR 0 SRC	PFI 8
CTR 0 GATE	PFI 9
CTR 0 AUX	PFI 10
CTR 0 OUT	PFI 12
CTR 0 A	PFI 8
CTR 0 Z	PFI 9
CTR 0 B	PFI 10
CTR 1 SRC	PFI 3
CTR 1 GATE	PFI 4
CTR 1 AUX	PFI 11
CTR 1 OUT	PFI 13
CTR 1 A	PFI 3
CTR 1 Z	PFI 4
CTR 1 B	PFI 11
FREQ OUT	PFI 14



Note For a detailed description of each signal, refer to the *I/O Connector Signal Descriptions* section of Chapter 3, *Connector and LED Information*.



Note For more information about default NI-DAQmx counter inputs, refer to *Connecting Counter Signals* in the *NI-DAQmx Help* or the *LabVIEW Help*.

USB-6251 BNC Important Links

The following list contains links specific to your DAQ device:

- **Specifications**—Refer to the *NI 6251 Specifications* for more detailed information about the USB-6251 BNC device.
- **LED Patterns**—Refer to the *LED Patterns* section of Chapter 3, *Connector and LED Information*, for information about the USB-6251 BNC LEDs.
- **Fuse Replacement**—Refer to the *USB Device Fuse Replacement* section of Chapter 1, *Getting Started*, for information about replacing the fuse on the USB-6251 BNC.
- **Accessory Options**—Refer to the *USB Device Accessories, USB Cable, and Power Supply* section of Chapter 2, *DAQ System Overview*, for more information.

USB-6251 Mass Termination

USB-6251 Mass Termination Pinout

Figure A-17 shows the pinout of the USB-6251 Mass Termination device.

Figure A-17. USB-6251 Mass Termination Pinout

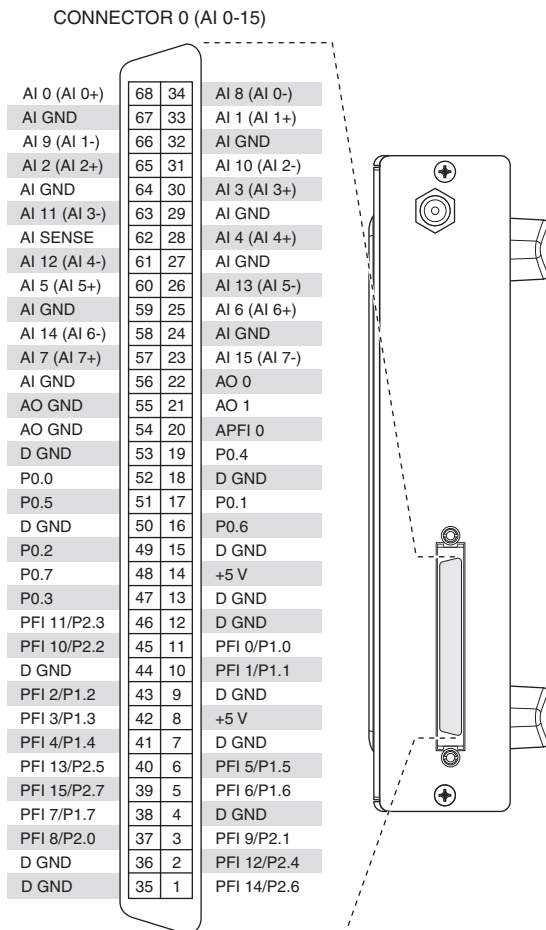

Table A-17. Default NI-DAQmx Counter/Timer Pins

Counter/Timer Signal	Default Pin Number (Name)
CTR 0 SRC	37 (PFI 8)
CTR 0 GATE	3 (PFI 9)

Table A-17. Default NI-DAQmx Counter/Timer Pins (Continued)

Counter/Timer Signal	Default Pin Number (Name)
CTR 0 AUX	45 (PFI 10)
CTR 0 OUT	2 (PFI 12)
CTR 0 A	37 (PFI 8)
CTR 0 Z	3 (PFI 9)
CTR 0 B	45 (PFI 10)
CTR 1 SRC	42 (PFI 3)
CTR 1 GATE	41 (PFI 4)
CTR 1 AUX	46 (PFI 11)
CTR 1 OUT	40 (PFI 13)
CTR 1 A	42 (PFI 3)
CTR 1 Z	41 (PFI 4)
CTR 1 B	46 (PFI 11)
FREQ OUT	1 (PFI 14)



Note For a detailed description of each signal, refer to the *I/O Connector Signal Descriptions* section of Chapter 3, *Connector and LED Information*.



Note For more information about default NI-DAQmx counter inputs, refer to *Connecting Counter Signals* in the *NI-DAQmx Help* or the *LabVIEW Help*.

USB-6229 Mass Termination Important Links

The following list contains links specific to your DAQ device:

- **Specifications**—Refer to the *NI 6229 Specifications* for more detailed information about the USB-6229 Mass Termination device.
- **LED Patterns**—Refer to the *LED Patterns* section of Chapter 3, *Connector and LED Information*, for information about the USB-6229 Mass Termination LEDs.
- **Fuse Replacement**—Refer to the *USB Device Fuse Replacement* section of Chapter 1, *Getting Started*, for information about replacing the fuse on the USB-6229 Mass Termination.
- **Accessory and Cabling Options**—Refer to the *68-Pin M Series Cables and Accessories* section of Chapter 2, *DAQ System Overview*, for more information.

NI 6254

PCI/PXI-6254 Pinout

Figure A-18 shows the pinout of the PCI/PXI-6254. The I/O signals appear on two 68-pin connectors.

Figure A-18. PCI/PXI-6254 Pinout

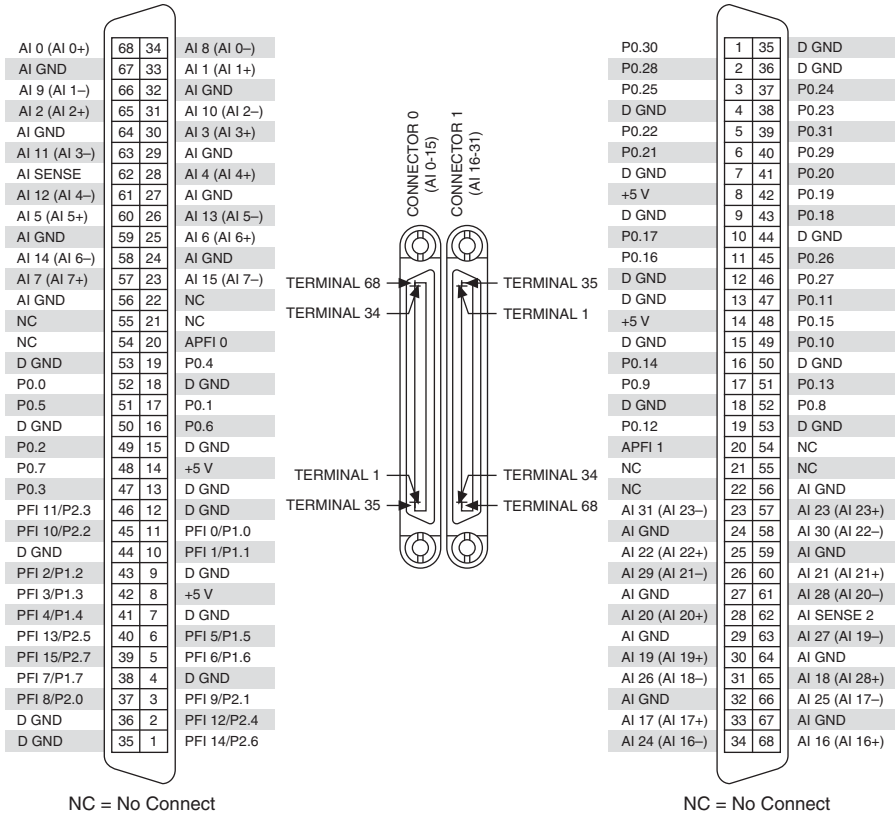

Table A-18. Default NI-DAQmx Counter/Timer Pins

Counter/Timer Signal	Default Connector 0 Pin Number (Name)
CTR 0 SRC	37 (PFI 8)
CTR 0 GATE	3 (PFI 9)
CTR 0 AUX	45 (PFI 10)
CTR 0 OUT	2 (PFI 12)
CTR 0 A	37 (PFI 8)
CTR 0 Z	3 (PFI 9)
CTR 0 B	45 (PFI 10)
CTR 1 SRC	42 (PFI 3)
CTR 1 GATE	41 (PFI 4)
CTR 1 AUX	46 (PFI 11)
CTR 1 OUT	40 (PFI 13)
CTR 1 A	42 (PFI 3)
CTR 1 Z	41 (PFI 4)
CTR 1 B	46 (PFI 11)
FREQ OUT	1 (PFI 14)



Note For a detailed description of each signal, refer to the *I/O Connector Signal Descriptions* section of Chapter 3, *Connector and LED Information*.



Note For more information about default NI-DAQmx counter inputs, refer to *Connecting Counter Signals* in the *NI-DAQmx Help* or the *LabVIEW Help*.

PCI/PXI-6254 Important Links

The following list contains links specific to your DAQ device:

- **Specifications**—Refer to the *NI 6254 Specifications* for more detailed information about the PCI/PXI-6254 device.
- **Accessory and Cabling Options**—Refer to the *68-Pin M Series Cables and Accessories* section of Chapter 2, *DAQ System Overview*, for more information.

NI 6255

The following sections contain information about the *PCI/PXI-6255*, *USB-6255 Screw Terminal*, and *USB-6255 Mass Termination*.

PCI/PXI-6255

PCI/PXI-6255 Pinout

Figure A-19 shows the pinout of the PCI/PXI-6255.

Figure A-19. PCI/PXI-6255 Pinout

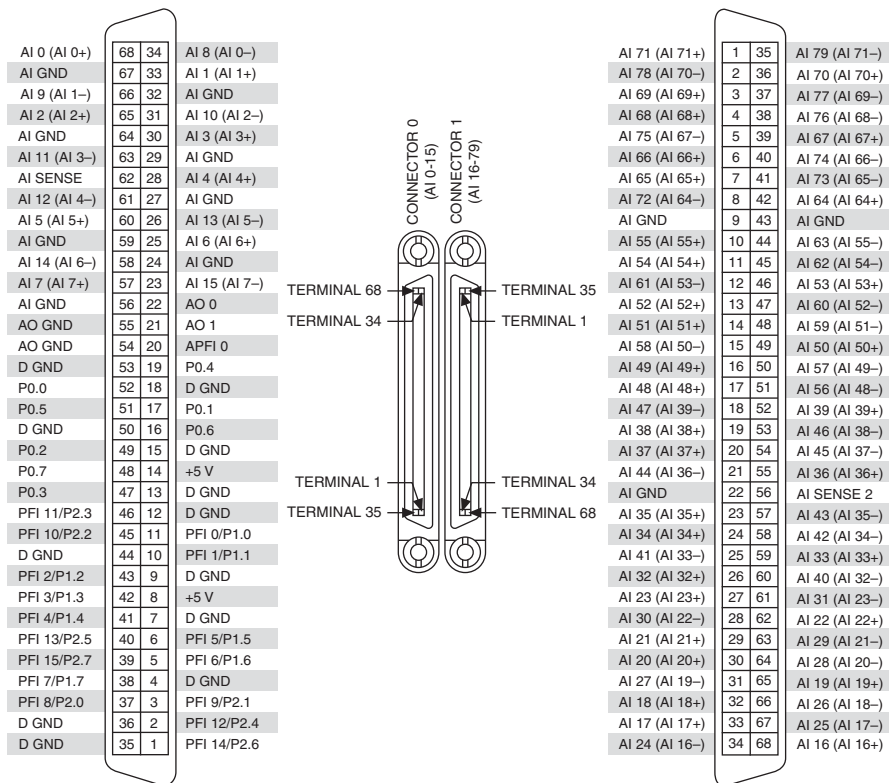

NC = No Connect

Table A-19. Default NI-DAQmx Counter/Timer Pins

Counter/Timer Signal	Default Connector 0 Pin Number (Name)
CTR 0 SRC	37 (PFI 8)
CTR 0 GATE	3 (PFI 9)
CTR 0 AUX	45 (PFI 10)
CTR 0 OUT	2 (PFI 12)
CTR 0 A	37 (PFI 8)
CTR 0 Z	3 (PFI 9)
CTR 0 B	45 (PFI 10)
CTR 1 SRC	42 (PFI 3)
CTR 1 GATE	41 (PFI 4)
CTR 1 AUX	46 (PFI 11)
CTR 1 OUT	40 (PFI 13)
CTR 1 A	42 (PFI 3)
CTR 1 Z	41 (PFI 4)
CTR 1 B	46 (PFI 11)
FREQ OUT	1 (PFI 14)



Note For a detailed description of each signal, refer to the *I/O Connector Signal Descriptions* section of Chapter 3, *Connector and LED Information*.



Note For more information about default NI-DAQmx counter inputs, refer to *Connecting Counter Signals* in the *NI-DAQmx Help* or the *LabVIEW Help*.

PCI/PXI-6255 Important Links

The following list contains links specific to your DAQ device:

- **Specifications**—Refer to the *NI 6255 Specifications* for more detailed information about the PCI/PXI-6255 device.
- **Accessory and Cabling Options**—Refer to the *68-Pin M Series Cables and Accessories* section of Chapter 2, *DAQ System Overview*, for more information.

USB-6255 Screw Terminal

USB-6255 Screw Terminal Pinout

Figure A-20 shows the pinout of the USB-6255 Screw Terminal.

Figure A-20. USB-6255 Screw Terminal Pinout

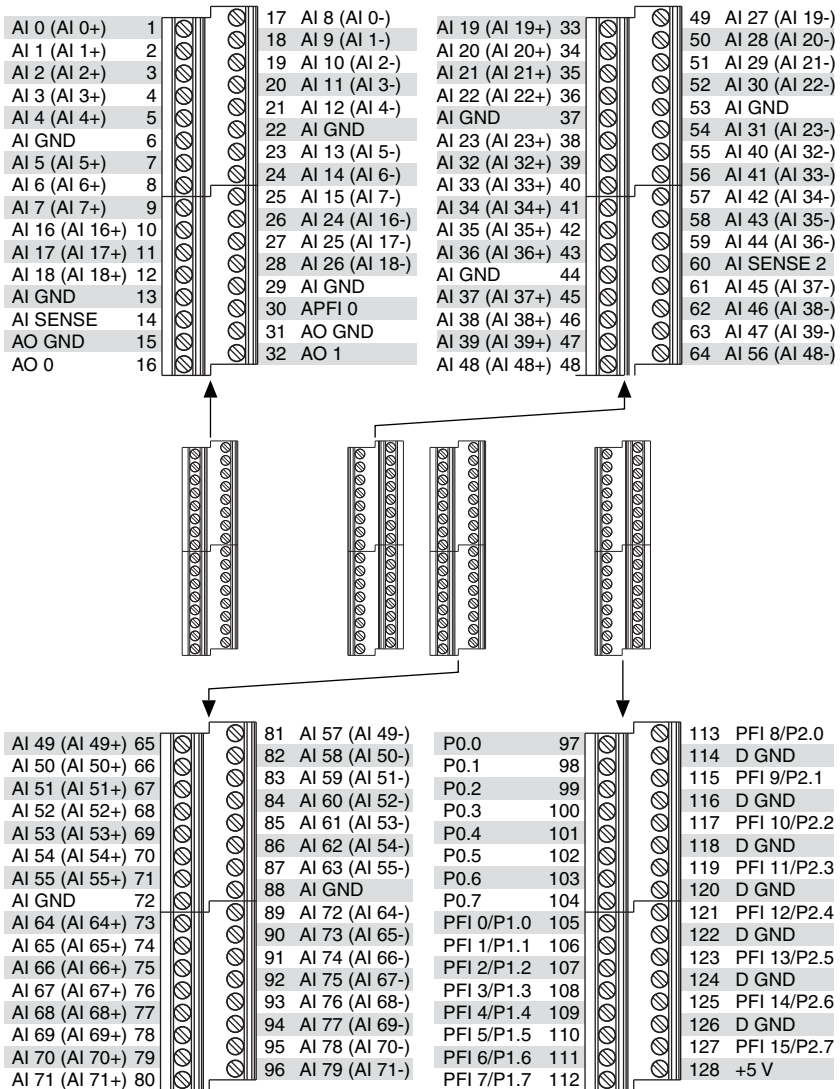

Table A-20. Default NI-DAQmx Counter/Timer Pins

Counter/Timer Signal	Default Pin Number (Name)
CTR 0 SRC	113 (PFI 8)
CTR 0 GATE	115 (PFI 9)
CTR 0 AUX	117 (PFI 10)
CTR 0 OUT	121 (PFI 12)
CTR 0 A	113 (PFI 8)
CTR 0 Z	115 (PFI 9)
CTR 0 B	117 (PFI 10)
CTR 1 SRC	108 (PFI 3)
CTR 1 GATE	109 (PFI 4)
CTR 1 AUX	119 (PFI 11)
CTR 1 OUT	123 (PFI 13)
CTR 1 A	108 (PFI 3)
CTR 1 Z	109 (PFI 4)
CTR 1 B	119 (PFI 11)
FREQ OUT	125 (PFI 14)



Note For a detailed description of each signal, refer to the *I/O Connector Signal Descriptions* section of Chapter 3, *Connector and LED Information*.



Note For more information about default NI-DAQmx counter inputs, refer to *Connecting Counter Signals* in the *NI-DAQmx Help* or the *LabVIEW Help*.

USB-6255 Screw Terminal Important Links

The following list contains links specific to your DAQ device:

- **Specifications**—Refer to the *NI 6255 Specifications* for more detailed information about the USB-6255 Screw Terminal device.
- **LED Patterns**—Refer to the *LED Patterns* section of Chapter 3, *Connector and LED Information*, for information about the USB-6255 Screw Terminal LEDs.
- **Fuse Replacement**—Refer to the *USB Device Fuse Replacement* section of Chapter 1, *Getting Started*, for information about replacing the fuse on the USB-6255 Screw Terminal.
- **Accessory Options**—Refer to the *USB Device Accessories, USB Cable, and Power Supply* section of Chapter 2, *DAQ System Overview*, for more information.

USB-6255 Mass Termination

USB-6255 Mass Termination Pinout

Figure A-21 shows the pinout of the USB-6255 Mass Termination device.

Figure A-21. USB-6255 Mass Termination Pinout

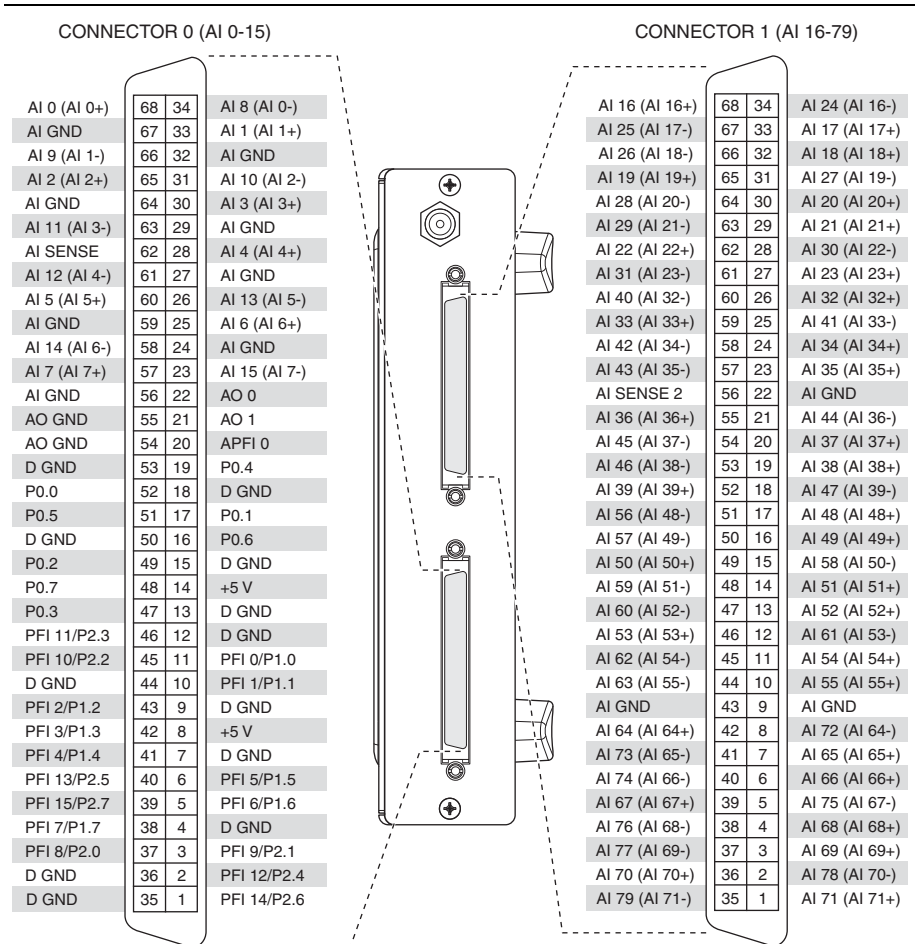

Table A-21. Default NI-DAQmx Counter/Timer Pins

Counter/Timer Signal	Default Connector 0 Pin Number (Name)
CTR 0 SRC	37 (PFI 8)
CTR 0 GATE	3 (PFI 9)

Table A-21. Default NI-DAQmx Counter/Timer Pins

Counter/Timer Signal	Default Connector 0 Pin Number (Name)
CTR 0 AUX	45 (PFI 10)
CTR 0 OUT	2 (PFI 12)
CTR 0 A	37 (PFI 8)
CTR 0 Z	3 (PFI 9)
CTR 0 B	45 (PFI 10)
CTR 1 SRC	42 (PFI 3)
CTR 1 GATE	41 (PFI 4)
CTR 1 AUX	46 (PFI 11)
CTR 1 OUT	40 (PFI 13)
CTR 1 A	42 (PFI 3)
CTR 1 Z	41 (PFI 4)
CTR 1 B	46 (PFI 11)
FREQ OUT	1 (PFI 14)



Note For a detailed description of each signal, refer to the *I/O Connector Signal Descriptions* section of Chapter 3, *Connector and LED Information*.



Note For more information about default NI-DAQmx counter inputs, refer to *Connecting Counter Signals* in the *NI-DAQmx Help* or the *LabVIEW Help*.

USB-6255 Mass Termination Important Links

The following list contains links specific to your DAQ device:

- **Specifications**—Refer to the *NI 6255 Specifications* for more detailed information about the USB-6255 Mass Termination device.
- **LED Patterns**—Refer to the *LED Patterns* section of Chapter 3, *Connector and LED Information*, for information about the USB-6255 Mass Termination LEDs.
- **Fuse Replacement**—Refer to the *USB Device Fuse Replacement* section of Chapter 1, *Getting Started*, for information about replacing the fuse on the USB-6255 Mass Termination.
- **Accessory and Cabling Options**—Refer to the *68-Pin M Series Cables and Accessories* section of Chapter 2, *DAQ System Overview*, for more information.

NI 6259

The following sections contain information about the *NI PCI/PCIe/PXI/PXIe-6259*, *USB-6259 Screw Terminal*, *USB-6259 BNC*, and *USB-6259 Mass Termination*.

NI PCI/PCIe/PXI/PXIe-6259

NI PCI/PCIe/PXI/PXIe-6259 Pinout

Figure A-22 shows the pinout of the NI PCI/PCIe/PXI/PXIe-6259. The I/O signals appear on two 68-pin connectors.

Figure A-22. NI PCI/PCIe/PXI/PXIe-6259 Pinout

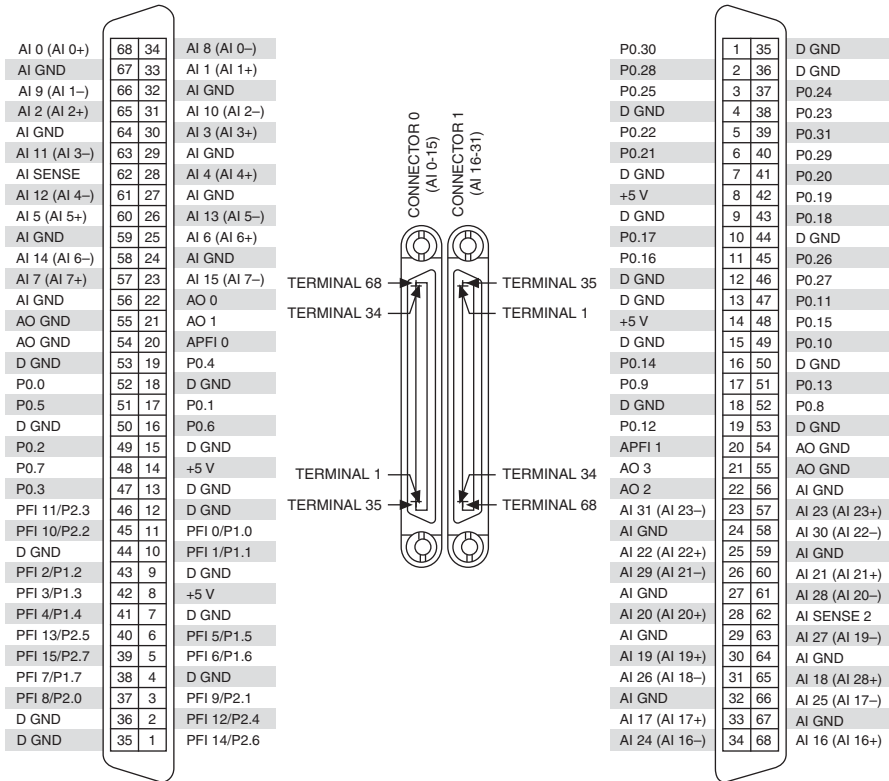

Table A-22. Default NI-DAQmx Counter/Timer Pins

Counter/Timer Signal	Default Connector 0 Pin Number (Name)
CTR 0 SRC	37 (PFI 8)
CTR 0 GATE	3 (PFI 9)
CTR 0 AUX	45 (PFI 10)
CTR 0 OUT	2 (PFI 12)
CTR 0 A	37 (PFI 8)
CTR 0 Z	3 (PFI 9)
CTR 0 B	45 (PFI 10)
CTR 1 SRC	42 (PFI 3)
CTR 1 GATE	41 (PFI 4)
CTR 1 AUX	46 (PFI 11)
CTR 1 OUT	40 (PFI 13)
CTR 1 A	42 (PFI 3)
CTR 1 Z	41 (PFI 4)
CTR 1 B	46 (PFI 11)
FREQ OUT	1 (PFI 14)



Note For a detailed description of each signal, refer to the *I/O Connector Signal Descriptions* section of Chapter 3, *Connector and LED Information*.



Note For more information about default NI-DAQmx counter inputs, refer to *Connecting Counter Signals* in the *NI-DAQmx Help* or the *LabVIEW Help*.

NI PCI/PCIe/PXI/PXIe-6259 Important Links

The following list contains links specific to your DAQ device:

- **Specifications**—Refer to the *NI 6259 Specifications* for more detailed information about the NI PCI/PCIe/PXI/PXIe-6259 device.
- **Accessory and Cabling Options**—Refer to the *68-Pin M Series Cables and Accessories* section of Chapter 2, *DAQ System Overview*, for more information.
- **PCI Express Disk Drive Power Connector**—Refer to the *RTSI Connector Pinout* section of Chapter 3, *Connector and LED Information*, for more information.

USB-6259 Screw Terminal

USB-6259 Screw Terminal Pinout

Figure A-23 shows the pinout of the USB-6259 Screw Terminal.

Figure A-23. USB-6259 Screw Terminal Pinout

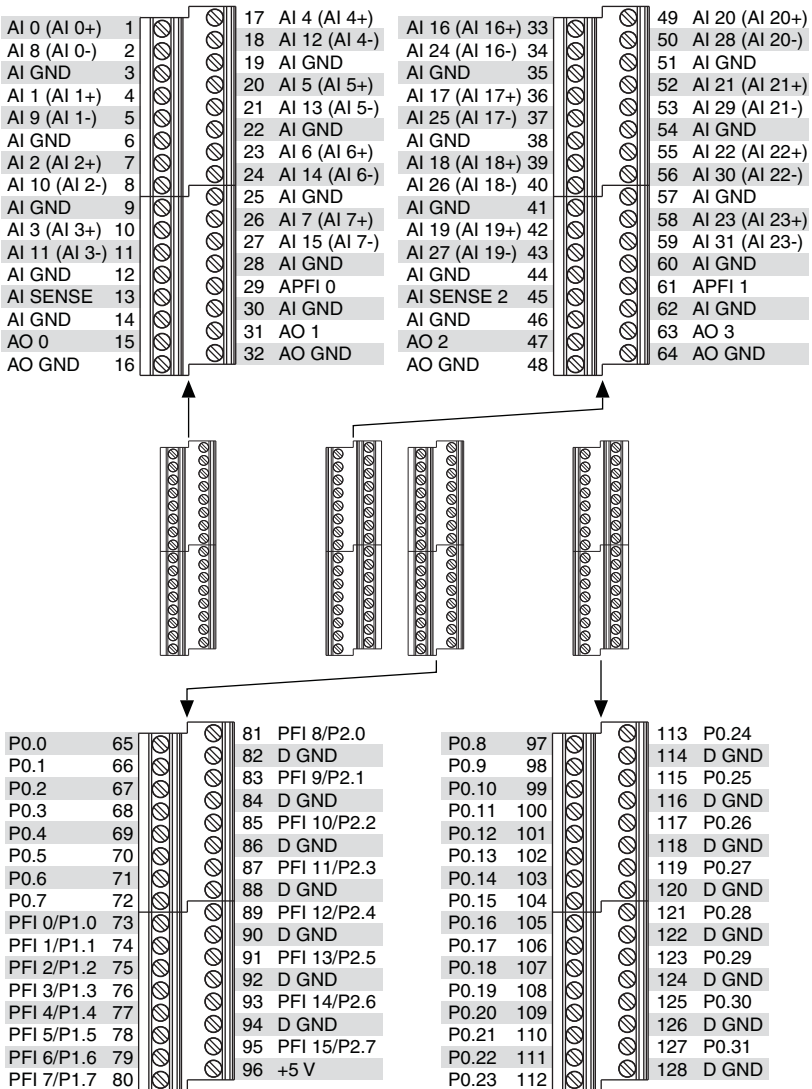

Table A-23. Default NI-DAQmx Counter/Timer Pins

Counter/Timer Signal	Default Pin Number (Name)
CTR 0 SRC	81 (PFI 8)
CTR 0 GATE	83 (PFI 9)
CTR 0 AUX	85 (PFI 10)
CTR 0 OUT	89 (PFI 12)
CTR 0 A	81 (PFI 8)
CTR 0 Z	83 (PFI 9)
CTR 0 B	85 (PFI 10)
CTR 1 SRC	76 (PFI 3)
CTR 1 GATE	77 (PFI 4)
CTR 1 AUX	87 (PFI 11)
CTR 1 OUT	91 (PFI 13)
CTR 1 A	76 (PFI 3)
CTR 1 Z	77 (PFI 4)
CTR 1 B	87 (PFI 11)
FREQ OUT	93 (PFI 14)



Note For a detailed description of each signal, refer to the *I/O Connector Signal Descriptions* section of Chapter 3, *Connector and LED Information*.



Note For more information about default NI-DAQmx counter inputs, refer to *Connecting Counter Signals* in the *NI-DAQmx Help* or the *LabVIEW Help*.

USB-6259 Screw Terminal Important Links

The following list contains links specific to your DAQ device:

- **Specifications**—Refer to the *NI 625x Specifications* for more detailed information about the USB-6259 Screw Terminal device.
- **LED Patterns**—Refer to the *LED Patterns* section of Chapter 3, *Connector and LED Information*, for information about the USB-6259 Screw Terminal LEDs.
- **Fuse Replacement**—Refer to the *USB Device Fuse Replacement* section of Chapter 1, *Getting Started*, for information about replacing the fuse on the USB-6259 Screw Terminal.
- **Accessory Options**—Refer to the *USB Device Accessories, USB Cable, and Power Supply* section of Chapter 2, *DAQ System Overview*, for more information.

USB-6259 BNC

USB-6259 BNC Pinout

Figure A-24 shows the pinout of the USB-6259 BNC.

Figure A-24. USB-6259 BNC Top Panel and Pinout

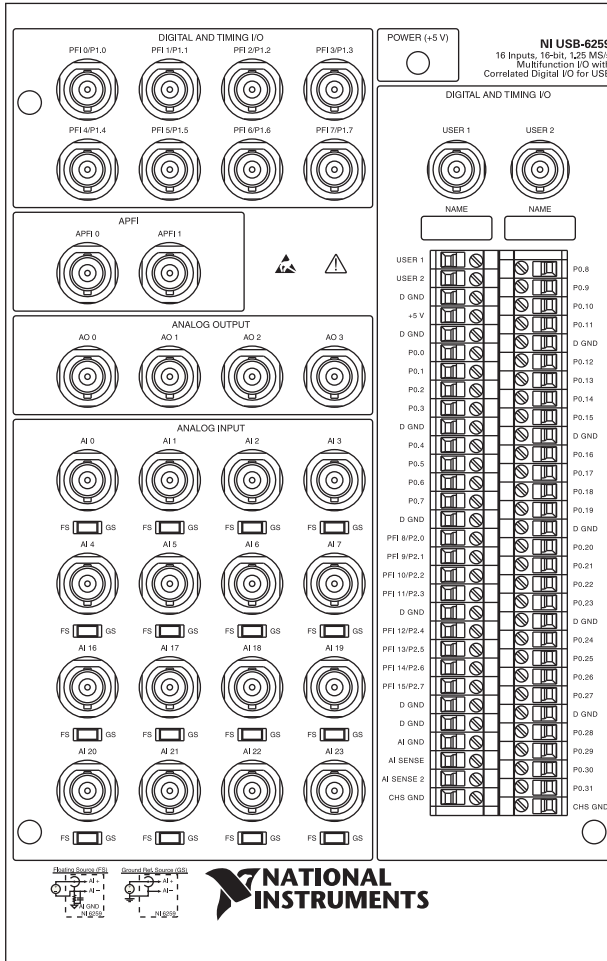

Table A-24. Default NI-DAQmx Counter/Timer Pins

Counter/Timer Signal	Default Pin Name
CTR 0 SRC	PFI 8
CTR 0 GATE	PFI 9
CTR 0 AUX	PFI 10
CTR 0 OUT	PFI 12
CTR 0 A	PFI 8
CTR 0 Z	PFI 9
CTR 0 B	PFI 10
CTR 1 SRC	PFI 3
CTR 1 GATE	PFI 4
CTR 1 AUX	PFI 11
CTR 1 OUT	PFI 13
CTR 1 A	PFI 3
CTR 1 Z	PFI 4
CTR 1 B	PFI 11
FREQ OUT	PFI 14



Note For a detailed description of each signal, refer to the *I/O Connector Signal Descriptions* section of Chapter 3, *Connector and LED Information*.



Note For more information about default NI-DAQmx counter inputs, refer to *Connecting Counter Signals* in the *NI-DAQmx Help* or the *LabVIEW Help*.

USB-6259 BNC Important Links

The following list contains links specific to your DAQ device:

- **Specifications**—Refer to the *NI 6259 Specifications* for more detailed information about the USB-6259 BNC device.
- **LED Patterns**—Refer to the *LED Patterns* section of Chapter 3, *Connector and LED Information*, for information about the USB-6259 BNC LEDs.
- **Fuse Replacement**—Refer to the *USB Device Fuse Replacement* section of Chapter 1, *Getting Started*, for information about replacing the fuse on the USB-6259 BNC.
- **Accessory Options**—Refer to the *USB Device Accessories, USB Cable, and Power Supply* section of Chapter 2, *DAQ System Overview*, for more information.

USB-6259 Mass Termination

USB-6259 Mass Termination Pinout

Figure A-25 shows the pinout of the USB-6259 Mass Termination device.

Figure A-25. USB-6259 Mass Termination Pinout

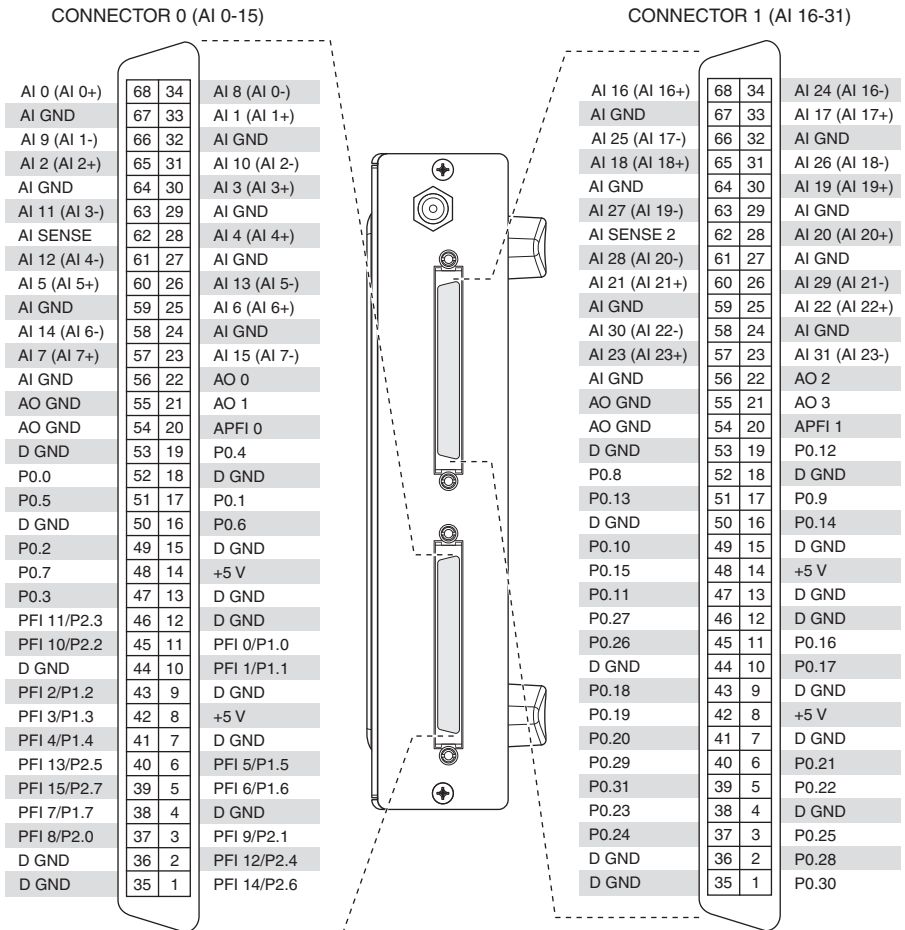

Table A-25. Default NI-DAQmx Counter/Timer Pins

Counter/Timer Signal	Default Connector 0 Pin Number (Name)
CTR 0 SRC	37 (PFI 8)
CTR 0 GATE	3 (PFI 9)

Table A-25. Default NI-DAQmx Counter/Timer Pins (Continued)

Counter/Timer Signal	Default Connector 0 Pin Number (Name)
CTR 0 AUX	45 (PFI 10)
CTR 0 OUT	2 (PFI 12)
CTR 0 A	37 (PFI 8)
CTR 0 Z	3 (PFI 9)
CTR 0 B	45 (PFI 10)
CTR 1 SRC	42 (PFI 3)
CTR 1 GATE	41 (PFI 4)
CTR 1 AUX	46 (PFI 11)
CTR 1 OUT	40 (PFI 13)
CTR 1 A	42 (PFI 3)
CTR 1 Z	41 (PFI 4)
CTR 1 B	46 (PFI 11)
FREQ OUT	1 (PFI 14)



Note For a detailed description of each signal, refer to the *I/O Connector Signal Descriptions* section of Chapter 3, *Connector and LED Information*.



Note For more information about default NI-DAQmx counter inputs, refer to *Connecting Counter Signals* in the *NI-DAQmx Help* or the *LabVIEW Help*.

USB-6259 Mass Termination Important Links

The following list contains links specific to your DAQ device:

- **Specifications**—Refer to the *NI 6259 Specifications* for more detailed information about the USB-6259 Mass Termination device.
- **LED Patterns**—Refer to the *LED Patterns* section of Chapter 3, *Connector and LED Information*, for information about the USB-6259 Mass Termination LEDs.
- **Fuse Replacement**—Refer to the *USB Device Fuse Replacement* section of Chapter 1, *Getting Started*, for information about replacing the fuse on the USB-6259 Mass Termination.
- **Accessory and Cabling Options**—Refer to the *68-Pin M Series Cables and Accessories* section of Chapter 2, *DAQ System Overview*, for more information.

NI 6280

PCI/PXI-6280 Pinout

Figure A-26 shows the pinout of the PCI/PXI-6280.

Figure A-26. PCI/PXI-6280 Pinout

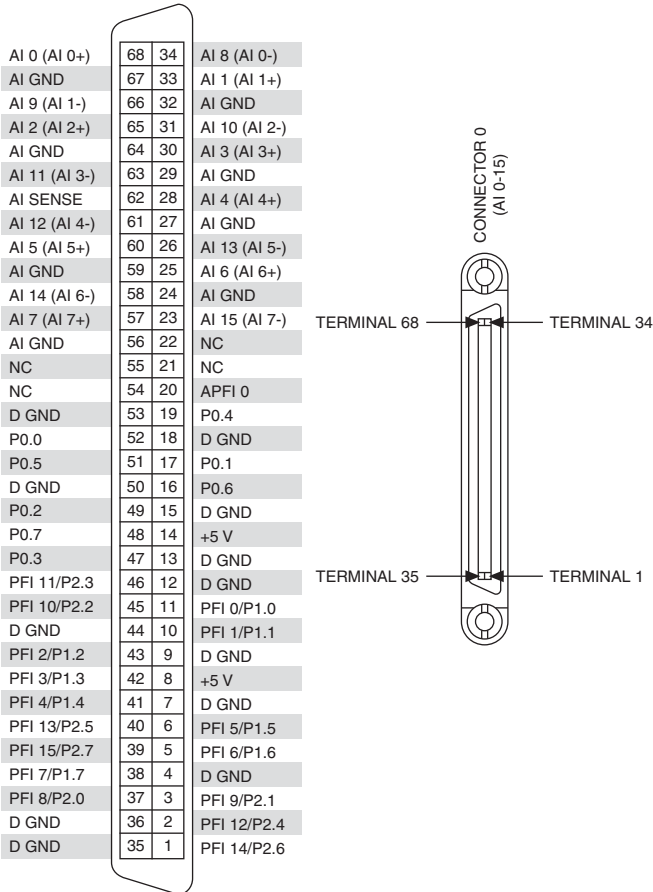

NC = No Connect

Table A-26. Default NI-DAQmx Counter/Timer Pins

Counter/Timer Signal	Default Pin Number (Name)
CTR 0 SRC	37 (PFI 8)
CTR 0 GATE	3 (PFI 9)
CTR 0 AUX	45 (PFI 10)
CTR 0 OUT	2 (PFI 12)
CTR 0 A	37 (PFI 8)
CTR 0 Z	3 (PFI 9)
CTR 0 B	45 (PFI 10)
CTR 1 SRC	42 (PFI 3)
CTR 1 GATE	41 (PFI 4)
CTR 1 AUX	46 (PFI 11)
CTR 1 OUT	40 (PFI 13)
CTR 1 A	42 (PFI 3)
CTR 1 Z	41 (PFI 4)
CTR 1 B	46 (PFI 11)
FREQ OUT	1 (PFI 14)



Note For a detailed description of each signal, refer to the *I/O Connector Signal Descriptions* section of Chapter 3, *Connector and LED Information*.



Note For more information about default NI-DAQmx counter inputs, refer to *Connecting Counter Signals* in the *NI-DAQmx Help* or the *LabVIEW Help*.

PCI/PXI-6280 Important Links

The following list contains links specific to your DAQ device:

- **Specifications**—Refer to the *NI 6280 Specifications* for more detailed information about the PCI/PXI-6280 device.
- **Accessory and Cabling Options**—Refer to the *68-Pin M Series Cables and Accessories* section of Chapter 2, *DAQ System Overview*, for more information.

NI 6281

The following sections contain information about the *PCI/PXI-6281*, *USB-6281 Screw Terminal*, and *USB-6281 Mass Termination*.

PCI/PXI-6281

PCI/PXI-6281 Pinout

Figure A-27 shows the pinout of the PCI/PXI-6281.

Figure A-27. PCI/PXI-6281 Pinout

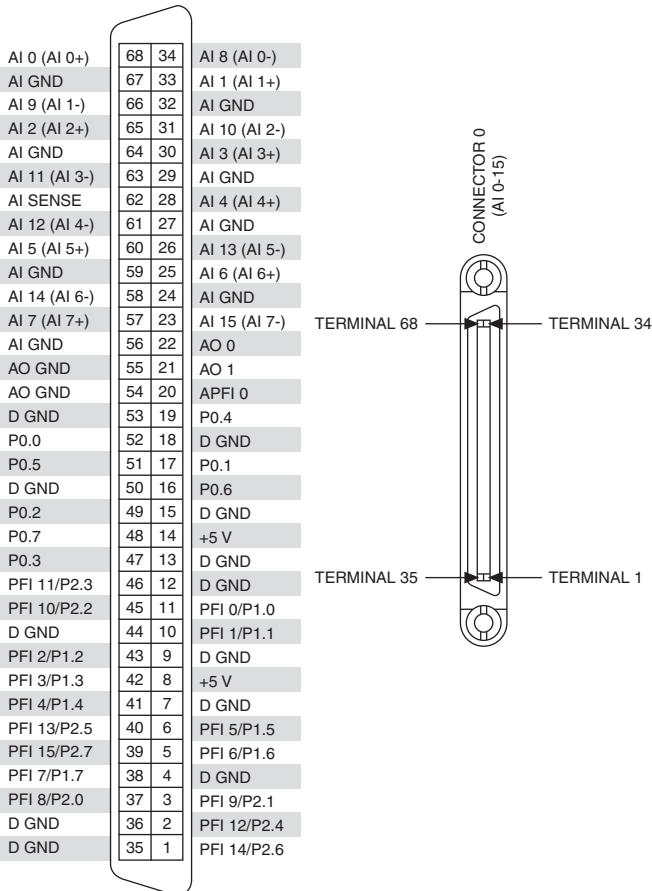

Table A-27. Default NI-DAQmx Counter/Timer Pins

Counter/Timer Signal	Default Pin Number (Name)
CTR 0 SRC	37 (PFI 8)
CTR 0 GATE	3 (PFI 9)
CTR 0 AUX	45 (PFI 10)
CTR 0 OUT	2 (PFI 12)
CTR 0 A	37 (PFI 8)
CTR 0 Z	3 (PFI 9)
CTR 0 B	45 (PFI 10)
CTR 1 SRC	42 (PFI 3)
CTR 1 GATE	41 (PFI 4)
CTR 1 AUX	46 (PFI 11)
CTR 1 OUT	40 (PFI 13)
CTR 1 A	42 (PFI 3)
CTR 1 Z	41 (PFI 4)
CTR 1 B	46 (PFI 11)
FREQ OUT	1 (PFI 14)



Note For a detailed description of each signal, refer to the *I/O Connector Signal Descriptions* section of Chapter 3, *Connector and LED Information*.



Note For more information about default NI-DAQmx counter inputs, refer to *Connecting Counter Signals* in the *NI-DAQmx Help* or the *LabVIEW Help*.

PCI/PXI-6281 Important Links

The following list contains links specific to your DAQ device:

- **Specifications**—Refer to the *NI 6281 Specifications* for more detailed information about the PCI/PXI-6281 device.
- **Accessory and Cabling Options**—Refer to the *68-Pin M Series Cables and Accessories* section of Chapter 2, *DAQ System Overview*, for more information.

USB-6281 Screw Terminal

USB-6281 Screw Terminal Pinout

Figure A-15 shows the pinout of the USB-6281 Screw Terminal.

Figure A-28. USB-6281 Screw Terminal Pinout

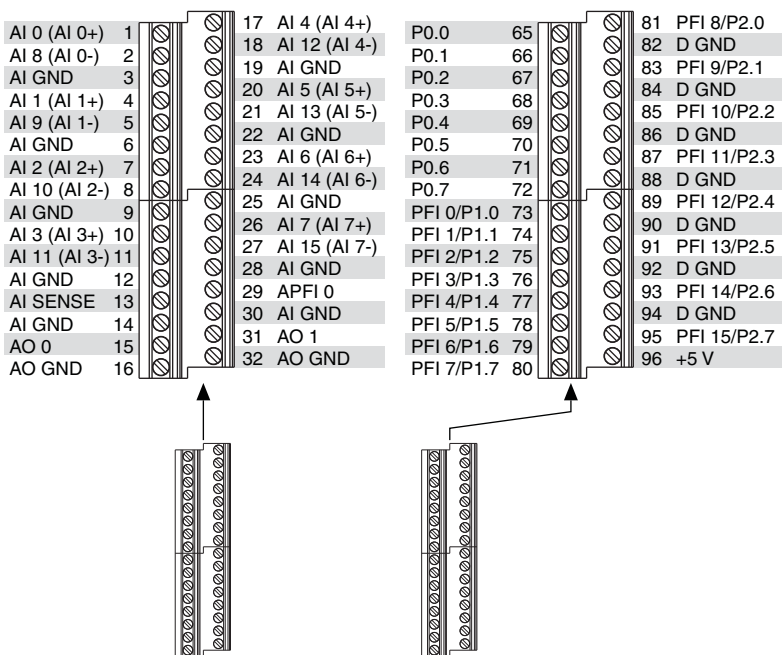

Table A-28. Default NI-DAQmx Counter/Timer Pins

Counter/Timer Signal	Default Pin Number (Name)
CTR 0 SRC	81 (PFI 8)
CTR 0 GATE	83 (PFI 9)
CTR 0 AUX	85 (PFI 10)
CTR 0 OUT	89 (PFI 12)
CTR 0 A	81 (PFI 8)
CTR 0 Z	83 (PFI 9)
CTR 0 B	85 (PFI 10)
CTR 1 SRC	76 (PFI 3)

Table A-28. Default NI-DAQmx Counter/Timer Pins (Continued)

Counter/Timer Signal	Default Pin Number (Name)
CTR 1 GATE	77 (PFI 4)
CTR 1 AUX	87 (PFI 11)
CTR 1 OUT	91 (PFI 13)
CTR 1 A	76 (PFI 3)
CTR 1 Z	77 (PFI 4)
CTR 1 B	87 (PFI 11)
FREQ OUT	93 (PFI 14)



Note For a detailed description of each signal, refer to the *I/O Connector Signal Descriptions* section of Chapter 3, *Connector and LED Information*.



Note For more information about default NI-DAQmx counter inputs, refer to *Connecting Counter Signals* in the *NI-DAQmx Help* or the *LabVIEW Help*.

USB-6281 Screw Terminal Important Links

The following list contains links specific to your DAQ device:

- **Specifications**—Refer to the *NI 6281 Specifications* for more detailed information about the USB-6281 Screw Terminal device.
- **LED Patterns**—Refer to the *LED Patterns* section of Chapter 3, *Connector and LED Information*, for information about the USB-6281 Screw Terminal LEDs.
- **Fuse Replacement**—Refer to the *USB Device Fuse Replacement* section of Chapter 1, *Getting Started*, for information about replacing the fuse on the USB-6259 Screw Terminal.
- **Accessory Options**—Refer to the *USB Device Accessories, USB Cable, and Power Supply* section of Chapter 2, *DAQ System Overview*, for more information.

USB-6281 Mass Termination

USB-6281 Mass Termination Pinout

Figure A-17 shows the pinout of the USB-6281 Mass Termination device.

Figure A-29. USB-6281 Mass Termination Pinout

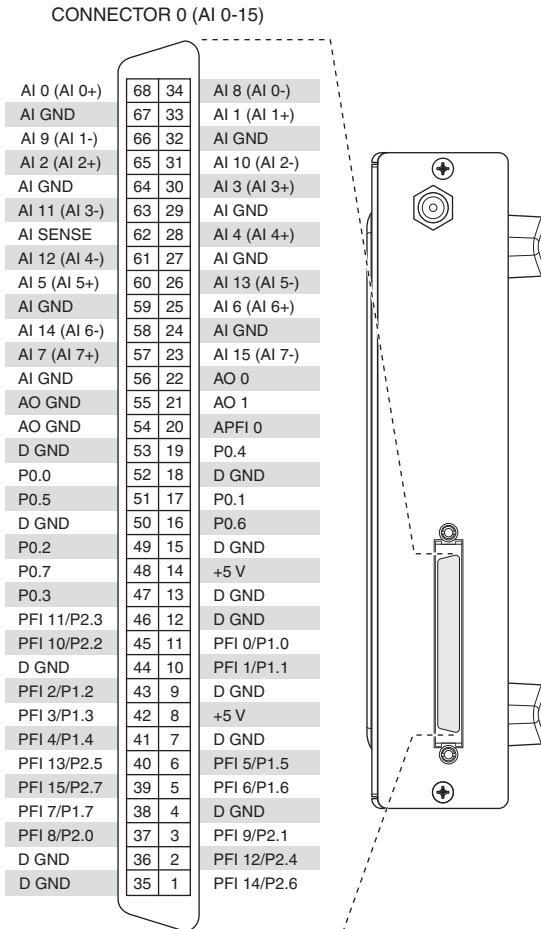

Table A-29. Default NI-DAQmx Counter/Timer Pins

Counter/Timer Signal	Default Pin Number (Name)
CTR 0 SRC	37 (PFI 8)
CTR 0 GATE	3 (PFI 9)

Table A-29. Default NI-DAQmx Counter/Timer Pins (Continued)

Counter/Timer Signal	Default Pin Number (Name)
CTR 0 AUX	45 (PFI 10)
CTR 0 OUT	2 (PFI 12)
CTR 0 A	37 (PFI 8)
CTR 0 Z	3 (PFI 9)
CTR 0 B	45 (PFI 10)
CTR 1 SRC	42 (PFI 3)
CTR 1 GATE	41 (PFI 4)
CTR 1 AUX	46 (PFI 11)
CTR 1 OUT	40 (PFI 13)
CTR 1 A	42 (PFI 3)
CTR 1 Z	41 (PFI 4)
CTR 1 B	46 (PFI 11)
FREQ OUT	1 (PFI 14)



Note For a detailed description of each signal, refer to the *I/O Connector Signal Descriptions* section of Chapter 3, *Connector and LED Information*.



Note For more information about default NI-DAQmx counter inputs, refer to *Connecting Counter Signals* in the *NI-DAQmx Help* or the *LabVIEW Help*.

USB-6281 Mass Termination Important Links

The following list contains links specific to your DAQ device:

- **Specifications**—Refer to the *NI 6281 Specifications* for more detailed information about the USB-6281 Mass Termination device.
- **LED Patterns**—Refer to the *LED Patterns* section of Chapter 3, *Connector and LED Information*, for information about the USB-6281 Mass Termination LEDs.
- **Fuse Replacement**—Refer to the *USB Device Fuse Replacement* section of Chapter 1, *Getting Started*, for information about replacing the fuse on the USB-6281 Mass Termination.
- **Accessory and Cabling Options**—Refer to the *68-Pin M Series Cables and Accessories* section of Chapter 2, *DAQ System Overview*, for more information.

NI 6284

PCI/PXI-6284 Pinout

Figure A-30 shows the pinout of the PCI/PXI-6284. The I/O signals appear on two 68-pin connectors.

Figure A-30. PCI/PXI-6284 Pinout

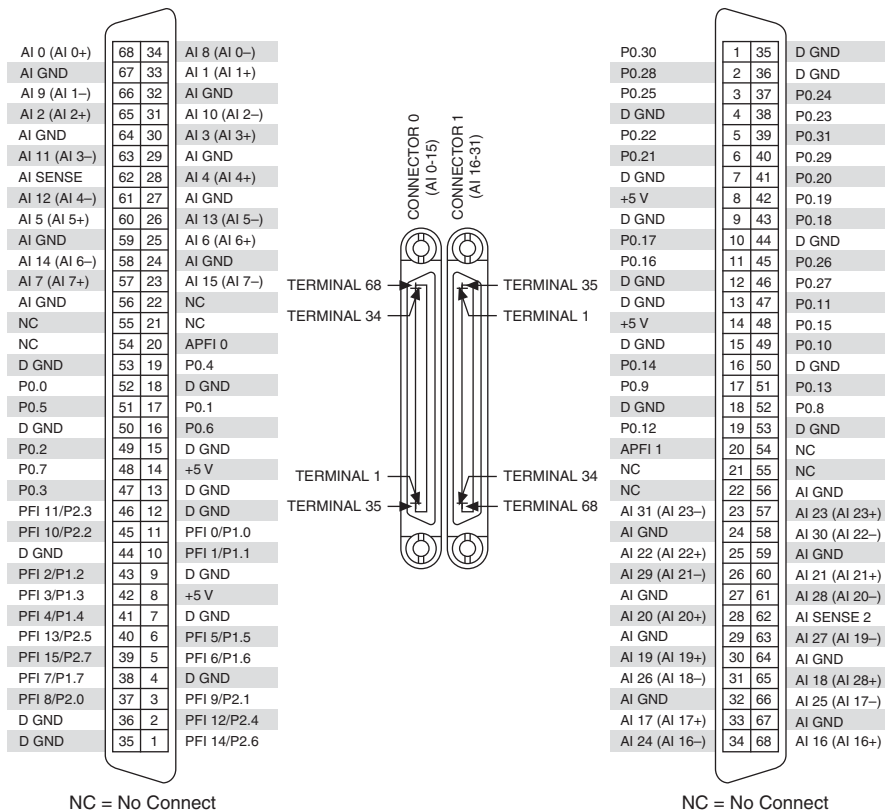

Table A-30. Default NI-DAQmx Counter/Timer Pins

Counter/Timer Signal	Default Connector 0 Pin Number (Name)
CTR 0 SRC	37 (PFI 8)
CTR 0 GATE	3 (PFI 9)
CTR 0 AUX	45 (PFI 10)

Table A-30. Default NI-DAQmx Counter/Timer Pins (Continued)

Counter/Timer Signal	Default Connector 0 Pin Number (Name)
CTR 0 OUT	2 (PFI 12)
CTR 0 A	37 (PFI 8)
CTR 0 Z	3 (PFI 9)
CTR 0 B	45 (PFI 10)
CTR 1 SRC	42 (PFI 3)
CTR 1 GATE	41 (PFI 4)
CTR 1 AUX	46 (PFI 11)
CTR 1 OUT	40 (PFI 13)
CTR 1 A	42 (PFI 3)
CTR 1 Z	41 (PFI 4)
CTR 1 B	46 (PFI 11)
FREQ OUT	1 (PFI 14)



Note For a detailed description of each signal, refer to the *I/O Connector Signal Descriptions* section of Chapter 3, *Connector and LED Information*.



Note For more information about default NI-DAQmx counter inputs, refer to *Connecting Counter Signals* in the *NI-DAQmx Help* or the *LabVIEW Help*.

PCI/PXI-6284 Important Links

The following list contains links specific to your DAQ device:

- **Specifications**—Refer to the *NI 6284 Specifications* for more detailed information about the PCI/PXI-6284 device.
- **Accessory and Cabling Options**—Refer to the *68-Pin M Series Cables and Accessories* section of Chapter 2, *DAQ System Overview*, for more information.

NI 6289

The following sections contain information about the [PCI/PXI-6289](#), [USB-6289 Screw Terminal](#), and [USB-6289 Mass Termination](#).

PCI/PXI-6289

PCI/PXI-6289 Pinout

Figure A-31 shows the pinout of the PCI/PXI-6289. The I/O signals appear on two 68-pin connectors.

Figure A-31. PCI/PXI-6289 Pinout

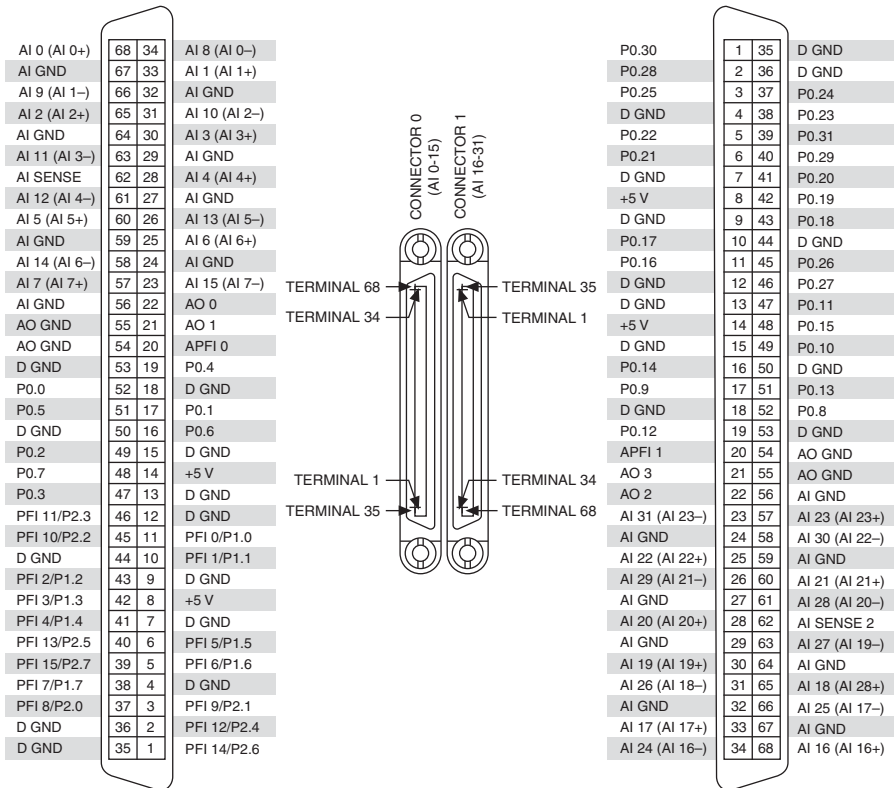

Table A-31. Default NI-DAQmx Counter/Timer Pins

Counter/Timer Signal	Default Connector 0 Pin Number (Name)
CTR 0 SRC	37 (PFI 8)
CTR 0 GATE	3 (PFI 9)
CTR 0 AUX	45 (PFI 10)
CTR 0 OUT	2 (PFI 12)
CTR 0 A	37 (PFI 8)
CTR 0 Z	3 (PFI 9)
CTR 0 B	45 (PFI 10)
CTR 1 SRC	42 (PFI 3)
CTR 1 GATE	41 (PFI 4)
CTR 1 AUX	46 (PFI 11)
CTR 1 OUT	40 (PFI 13)
CTR 1 A	42 (PFI 3)
CTR 1 Z	41 (PFI 4)
CTR 1 B	46 (PFI 11)
FREQ OUT	1 (PFI 14)



Note For a detailed description of each signal, refer to the *I/O Connector Signal Descriptions* section of Chapter 3, *Connector and LED Information*.



Note For more information about default NI-DAQmx counter inputs, refer to *Connecting Counter Signals* in the *NI-DAQmx Help* or the *LabVIEW Help*.

PCI/PXI-6289 Important Links

The following list contains links specific to your DAQ device:

- **Specifications**—Refer to the *NI 6289 Specifications* for more detailed information about the PCI/PXI-6289 device.
- **Accessory and Cabling Options**—Refer to the *68-Pin M Series Cables and Accessories* section of Chapter 2, *DAQ System Overview*, for more information.

USB-6289 Screw Terminal

USB-6289 Screw Terminal Pinout

Figure A-23 shows the pinout of the USB-6289 Screw Terminal.

Figure A-32. USB-6289 Screw Terminal Pinout

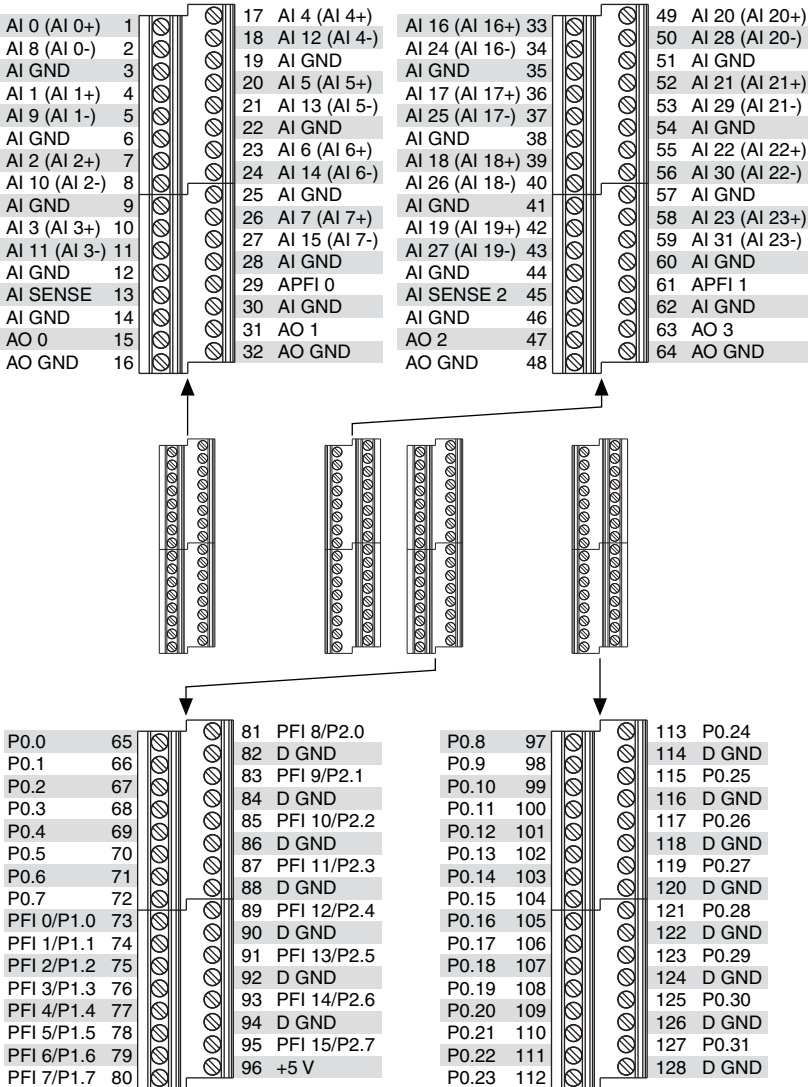

Table A-32. Default NI-DAQmx Counter/Timer Pins

Counter/Timer Signal	Default Pin Number (Name)
CTR 0 SRC	81 (PFI 8)
CTR 0 GATE	83 (PFI 9)
CTR 0 AUX	85 (PFI 10)
CTR 0 OUT	89 (PFI 12)
CTR 0 A	81 (PFI 8)
CTR 0 Z	83 (PFI 9)
CTR 0 B	85 (PFI 10)
CTR 1 SRC	76 (PFI 3)
CTR 1 GATE	77 (PFI 4)
CTR 1 AUX	87 (PFI 11)
CTR 1 OUT	91 (PFI 13)
CTR 1 A	76 (PFI 3)
CTR 1 Z	77 (PFI 4)
CTR 1 B	87 (PFI 11)
FREQ OUT	93 (PFI 14)



Note For a detailed description of each signal, refer to the *I/O Connector Signal Descriptions* section of Chapter 3, *Connector and LED Information*.



Note For more information about default NI-DAQmx counter inputs, refer to *Connecting Counter Signals* in the *NI-DAQmx Help* or the *LabVIEW Help*.

USB-6289 Screw Terminal Important Links

The following list contains links specific to your DAQ device:

- **Specifications**—Refer to the *NI 6289 Specifications* for more detailed information about the USB-6289 Screw Terminal device.
- **LED Patterns**—Refer to the *LED Patterns* section of Chapter 3, *Connector and LED Information*, for information about the USB-6289 Screw Terminal LEDs.
- **Fuse Replacement**—Refer to the *USB Device Fuse Replacement* section of Chapter 1, *Getting Started*, for information about replacing the fuse on the USB-6289 Screw Terminal.
- **Accessory Options**—Refer to the *USB Device Accessories, USB Cable, and Power Supply* section of Chapter 2, *DAQ System Overview*, for more information.

USB-6289 Mass Termination

USB-6289 Mass Termination Pinout

Figure A-25 shows the pinout of the USB-6289 Mass Termination device.

Figure A-33. USB-6289 Mass Termination Pinout

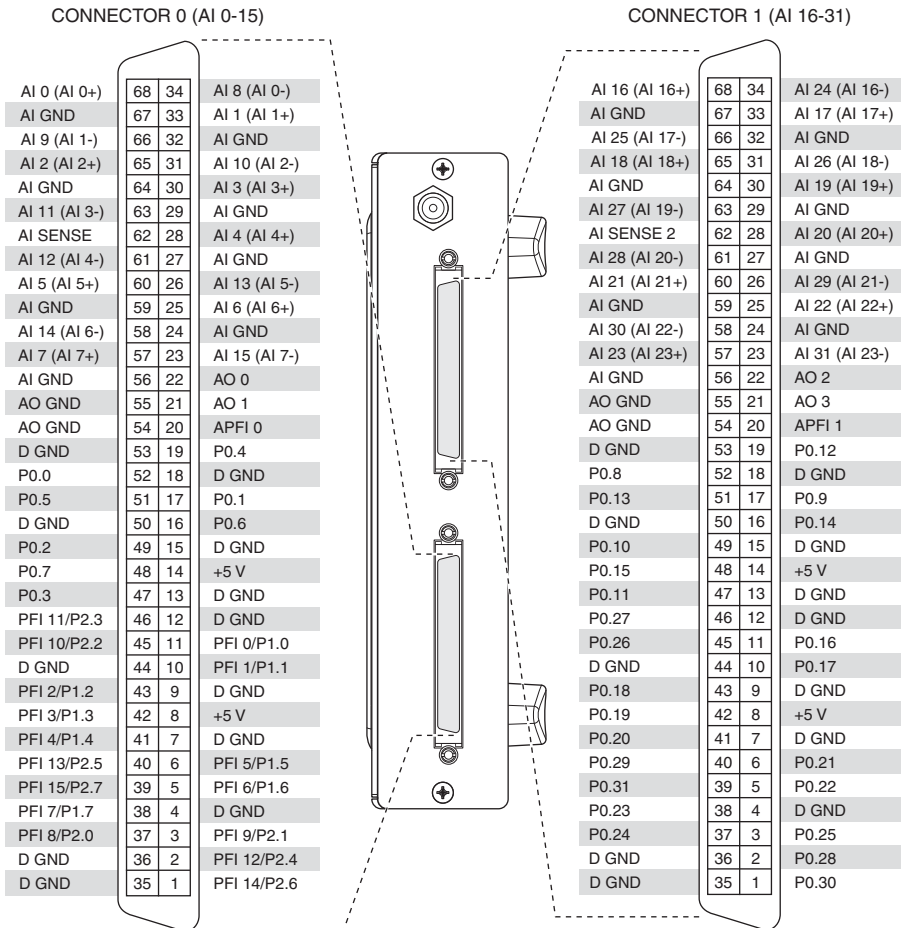

Table A-33. Default NI-DAQmx Counter/Timer Pins

Counter/Timer Signal	Default Connector 0 Pin Number (Name)
CTR 0 SRC	37 (PFI 8)
CTR 0 GATE	3 (PFI 9)

Table A-33. Default NI-DAQmx Counter/Timer Pins (Continued)

Counter/Timer Signal	Default Connector 0 Pin Number (Name)
CTR 0 AUX	45 (PFI 10)
CTR 0 OUT	2 (PFI 12)
CTR 0 A	37 (PFI 8)
CTR 0 Z	3 (PFI 9)
CTR 0 B	45 (PFI 10)
CTR 1 SRC	42 (PFI 3)
CTR 1 GATE	41 (PFI 4)
CTR 1 AUX	46 (PFI 11)
CTR 1 OUT	40 (PFI 13)
CTR 1 A	42 (PFI 3)
CTR 1 Z	41 (PFI 4)
CTR 1 B	46 (PFI 11)
FREQ OUT	1 (PFI 14)



Note For a detailed description of each signal, refer to the *I/O Connector Signal Descriptions* section of Chapter 3, *Connector and LED Information*.



Note For more information about default NI-DAQmx counter inputs, refer to *Connecting Counter Signals* in the *NI-DAQmx Help* or the *LabVIEW Help*.

USB-6289 Mass Termination Important Links

The following list contains links specific to your DAQ device:

- **Specifications**—Refer to the *NI 6289 Specifications* for more detailed information about the USB-6289 Mass Termination device.
- **LED Patterns**—Refer to the *LED Patterns* section of Chapter 3, *Connector and LED Information*, for information about the USB-6289 Mass Termination LEDs.
- **Fuse Replacement**—Refer to the *USB Device Fuse Replacement* section of Chapter 1, *Getting Started*, for information about replacing the fuse on the USB-6289 Mass Termination.
- **Accessory and Cabling Options**—Refer to the *68-Pin M Series Cables and Accessories* section of Chapter 2, *DAQ System Overview*, for more information.

Timing Diagrams

This appendix contains detailed timing information and diagrams for the M Series device blocks:

- [Analog Input Timing Diagrams](#)
- [Analog Output Timing Diagrams](#)
- [Digital I/O Timing Diagrams](#)
- [Counters Timing Diagrams](#)
- [Clock Generation Timing Diagrams](#)

Analog Input Timing Diagrams

The following sections describe the timing specifications and timing of the triggers and clock signals related to the analog input timing engine:

- **Input Timing**—Input timing relates to any signal external to the M Series device that is used as a clock or a trigger. This timing describes the delays involved with importing the external signal into the device.
- **Internal Timing**—Internal timing describes the relationship between internal signals. In general, how the input and other internal signals get used to generate output signals, such as the convert signal.
- **Output Timing**—Output timing refers to the timing parameters related to exporting signals internal to the device to a terminal for external use.

Figure B-1 is a simplified model of the M Series analog input timing engine.

Figure B-1. M Series Analog Input Timing Engine

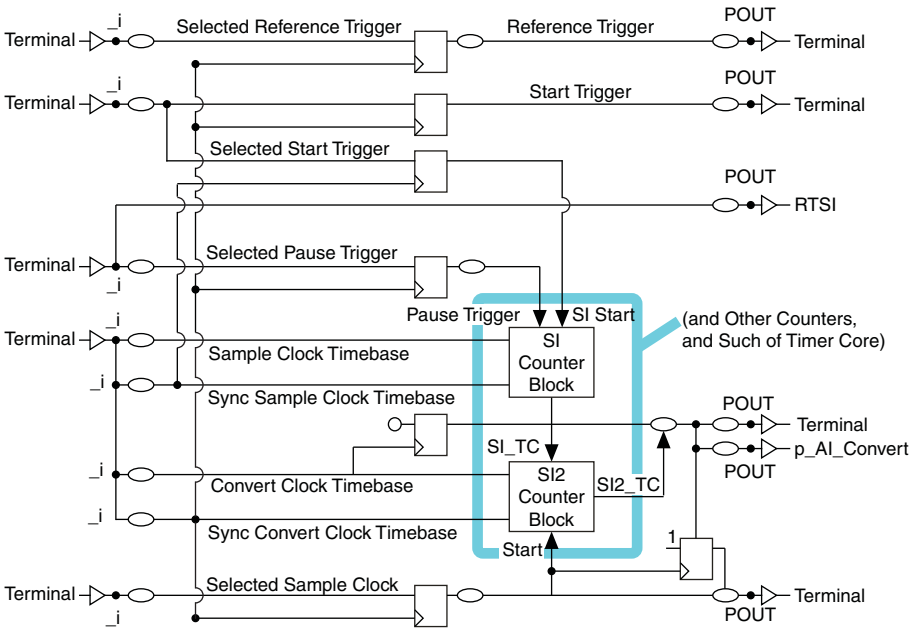

The following signals are used in Figure B-1 and in the following sections:

- **Terminal**—Refers to any device terminal, such as PFI or RTSI. These terminals are used as inputs and as outputs for signals.
- $_i$ —Refers to any internal signal available to the analog input timing engine for use. In the case of signals coming from an external terminal, this is the signal after it has been through the first input buffer. $_i$ also can refer to other internal signals such as internal timebases or signals coming from other blocks.
- **POUT**—Refers to any output signal right before it is driven to an output terminal.
- **Convert Clock Timebase and Sync Convert Clock Timebase**—Convert Clock Timebase is the source signal used to generate the signal that will actually cause the ADC to do a conversion (**p_AI_Convert**). This signal can be an internal or external timebase that is divided by the **SI2** counter, or can be an external Convert Clock signal. Sync Convert Clock Timebase is a signal related to Convert Clock Timebase that is used to synchronize external signals before they are used by circuits running from Convert Clock Timebase.
- **Sample Clock Timebase and Sync Sample Clock Timebase**—Sample Clock Timebase is the source for the **SI** counter and can be used to generate the sample timing. Each Sample Clock in turn triggers the generation of one or more converts. This signal can be an internal or external timebase. Sync Sample Clock Timebase is a signal related to Sample Clock Timebase that is used to synchronize external signals before they are used by circuits running from Sample Clock Timebase.

- **Selected Start Trigger and Start Trigger**—Start Trigger is the signal that starts the analog input timing engine. This signal can come from external signals, a software command, or internal sources. Selected Start Trigger is the signal chosen to be the Start Trigger before it is synchronized (just after the selection mux).
- **Selected Reference Trigger and Reference Trigger**—A Reference Trigger is a trigger that can stop the AI timing engine. If the Reference Trigger is enabled, the AI timing engine will stop acquiring data once it sees a valid event on the Reference Trigger and it has acquired the posttrigger number of samples. This signal can come from external signals, a software command, or internal sources. The Selected Reference Trigger is the signal chosen to be the Reference Trigger before it is synchronized (just after the selection mux).
- **Selected Sample Clock and Sample Clock**—Selected Sample Clock is the signal selected to become Sample Clock before any synchronization (just after the selection mux). The Sample Clock marks the beginning of a new sample. This signal can be an external or internal signal. When an internal signal, it can be generated with the SI counter dividing the Sample Clock Timebase signal. It also can come from an external terminal or from a signal from another internal resource inside the M Series device.
- **Selected Pause Trigger and Pause Trigger**—The Pause Trigger can be used to pause the acquisition for a certain period of time. Selected Pause Trigger is the signal that becomes the Pause Trigger signal before synchronization.
- **p_AI_Convert**—The signal that starts the conversions of data at the ADC component. This signal goes directly to the ADC, but copies can be routed to output terminals.

Input Timing

Input timing refers to the delays involved in importing external signals to be used as triggers or clocks in the AI timing engine. Figures B-2 and B-3 and Table B-1 describe the insertion delays for external signals.

Figure B-2. Input Timing and the Analog Input Timing Engine

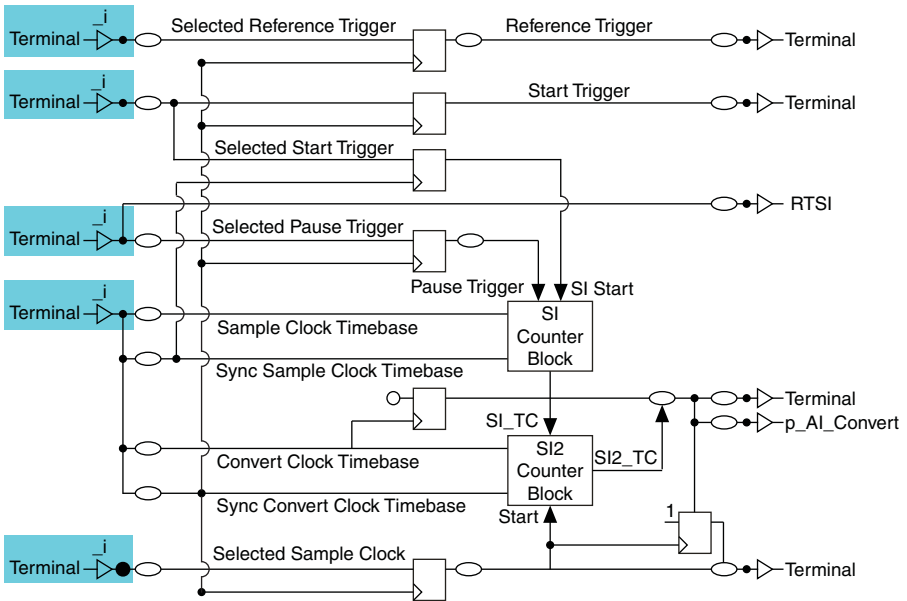

Figure B-3. Input Timing Diagram

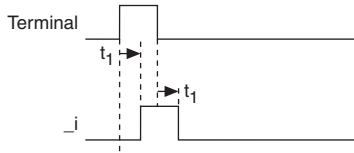

Table B-1. Input Timing

Time	From	To	Min (ns)		Max (ns)	
t_1^*	PFI	PFI_i	4.2	6.4	15.2	19.2
	RTSI	RTSI_i	0.9	2.2	2.0	3.0
	STAR	STAR_i	0.9	—	—	2.8

* The delay ranges given for PFI and RTSI represent the fastest and slowest terminal routing within the trigger group for a given condition (maximum or minimum timing). This difference can be useful when two external signals will be used together and the relative timing between the signals is important.

Internal Timing

AI Timing Clocks

The analog input timing engine has two levels of timing that control an AI acquisition. The first level is the convert level. This is the timing that controls when the analog to digital conversions take place. The SC, DIV, and SI2 counters run on this timing level. The signal that clocks this timing level is called Convert Clock Timebase. This signal can come from an internal source (for example, an internal timebase) or an external signal. It can be divided down using the SI2 counter, or it can be used directly (in external convert mode). In order to synchronize triggers to the Convert Clock Timebase signal, another related signal is generated called Sync Convert Clock Timebase. Sync Convert Clock Timebase is generated differently depending on the mode the AI timing engine is operating on:

- When Convert Clock Timebase is a signal that is divided down using the SI2 counter (either internal or external), it is considered to be a free-running clock. In this case, the Sync Convert Clock Timebase is the inverted version of the Convert Clock Timebase signal. The idea is to use the falling edge of the original signal to synchronize external signals before the rising edge of the Convert Clock Timebase occurs (after polarity selection). This case is the one described in this section.
- When Convert Clock Timebase is not going to be divided by the SI2 counter (in the case of an external convert signal), this signal is assumed to be not free-running and highly irregular. In this case, Sync Convert Clock Timebase is selected to be the actual external signal, and Convert Clock Timebase is a delayed version of the external signal. This delay is long enough so that external signals can be synchronized with Sync Convert Clock Timebase and used by Convert Clock Timebase. For timing diagrams and parameters for this case, refer to the [Convert Clock](#) section.

The second level of timing is the sample level. Basically, converts are grouped in sets called samples, and the timing of the samples can be independent from the timing of the converts. The M Series device can use a timebase to generate the sample timing. This timebase is called Sample Clock Timebase. This signal can be internal (for example, an internal timebase) or external. Either way, the signal gets divided in the SI counter and used to generate Sample Clock signals (which in turn, signal the start of a sample). In order to synchronize external triggers to the Sample Clock Timebase, another related signal is created, Sync Sample Clock Timebase. This is always the inverted signal selected to be Sample Clock Timebase, while the Sample Clock Timebase signal is a copy without inversion of the signal. The idea is that for each significant edge of the Sample Clock Timebase, there is a significant edge of the Sync Sample Clock Timebase signal that occurs before Sample Clock Timebase and that can be used to synchronize the input triggers.

The source for Convert Clock Timebase and Sample Clock Timebase is the internal signal bus, `_i`. The timing of this signal is described in relation to this common point. The Convert Clock Timebase and Sample Clock Timebase can be asynchronous from each other.

Figure B-4. AI Timing Clocks and the Analog Input Timing Engine

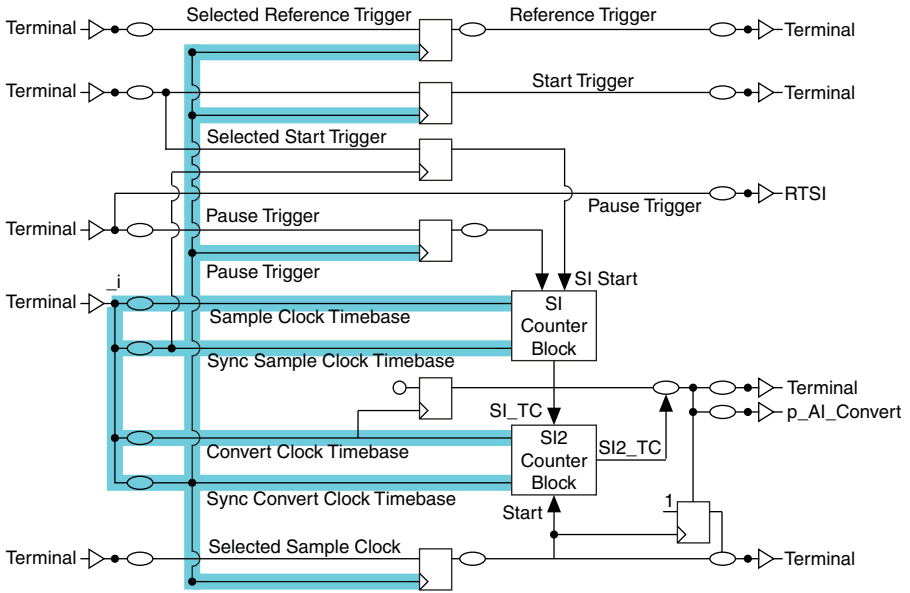

Figure B-5. AI Timing Clocks Timing Diagram

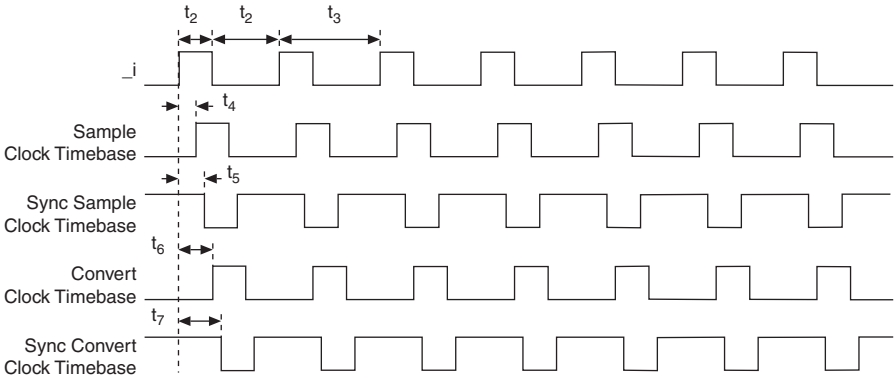

Table B-2. AI Timing Clocks Timing

Time	Description	Line	Min (ns)	Max (ns)
t_2	Minimum Pulse Width	—	12.5	—
t_3	Minimum Period	—	50.0	—
t_4	Delay to Sample Clock Timebase	PFI	3.8	9.3
		RTSI	3.5	9.0
		STAR	3.0	6.4
t_5	Delay to Sync Sample Clock Timebase	PFI	3.4	8.5
		RTSI	3.2	8.3
		STAR	2.7	5.6
t_6	Delay to Convert Clock Timebase	PFI	4.1	10.2
		RTSI	3.9	9.9
		STAR	3.4	7.3
t_7	Delay to Sync Convert Clock Timebase	PFI	3.6	8.9
		RTSI	3.3	8.6
		STAR	2.9	6.0

Convert Clock

Convert Clock is the signal that determines when an analog to digital conversion is started. The signal going to the ADC is called p_AI_Convert. Convert Clock also can be routed to several external I/O terminals for external use. Convert Clock is always generated from the Convert Clock Timebase signal, either directly or indirectly (by dividing it down using the SI2 counter). If the SI2 counter is used, it is assumed that a reliable free-running clock is being used. Refer to the *AI Timing Clocks* section for the timing relationship between Convert Clock Timebase and Sync Convert Clock Timebase. If the SI2 counter is not being used (external convert case), the Convert Clock Timebase is assumed to be not free-running and the relationship between the Convert Clock Timebase and the Sync Convert Clock Timebase is an asynchronous delay.

Whether the SI2 counter is used or not, the timing parameters in the generation of Convert Clock are the same starting at the Convert Clock Timebase signal.

Figure B-6. Convert Clock and the Analog Input Timing Engine

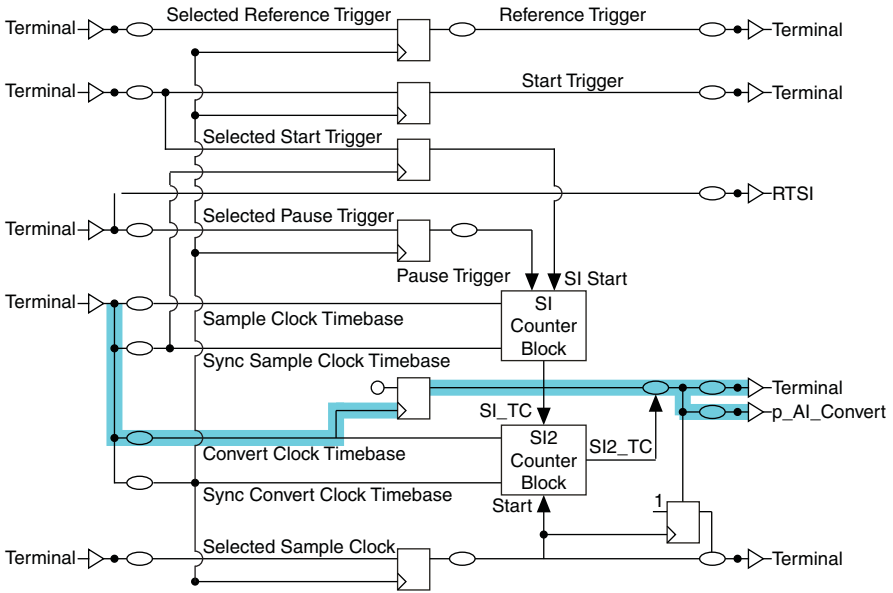

Figure B-7. Convert Clock Timing Diagram

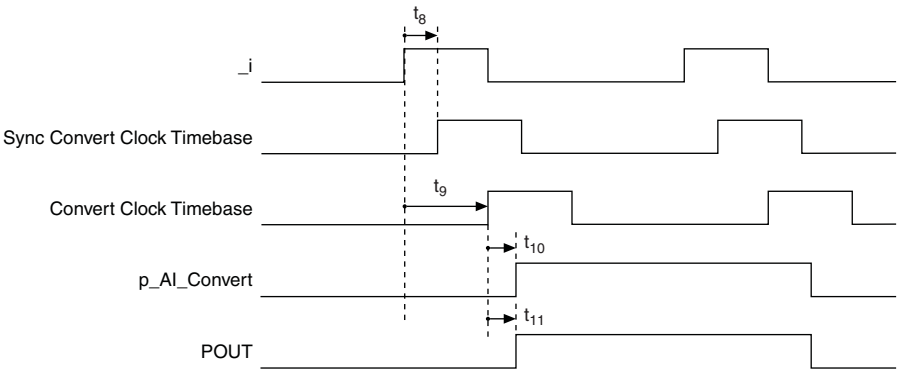
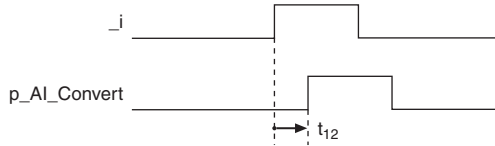

Table B-3. Convert Clock Timing

Time	Description	Line	Min (ns)	Max (ns)
t_8	Delay from $_i$ to Sync Convert Clock Timebase	PFI	6.4	15.9
		RTSI	6.0	15.6
		STAR	5.7	12.9

Table B-3. Convert Clock Timing (Continued)

Time	Description	Line	Min (ns)	Max (ns)
t_9	Delay from $_i$ to Convert Clock Timebase	PFI	16.2	39.1
		RTSI	16.0	38.8
		STAR	15.5	36.1
t_{10}	Delay from Convert Clock Timebase to $p_AI_Convert$	—	6.0	13.0
t_{11}	Delay from Convert Clock Timebase to Convert Clock, when exported to an external terminal (POUT)	PFI	4.6	10.8
		RTSI	4.6	10.5

Figure B-8. Convert Clock and Any Internal Signal Timing Diagram**Table B-4.** Convert Clock and Any Internal Signal Timing

Time	Description	Line	Min (ns)	Max (ns)
t_{12}	$_i$ to $p_AI_Convert$ in external convert mode	PFI	22.2	52.1
		RTSI	22.1	51.8
		STAR	21.5	49.1

Start Trigger

The Start Trigger is the signal that starts an AI acquisition. This signal can come from an external source (through an external terminal) or from an internal source. One possible internal source is a software-generated pulse. A multiplexer selects from all the possible sources (all of them at $_i$ level) and outputs a signal called Selected Start Trigger. Selected Start Trigger then gets sent to the two timing levels in the AI section (the Convert Clock Timebase and the Sample Clock Timebase timing level) for synchronization to each clock. Once the Convert Clock Timebase timing domain has received a valid Start Trigger, the AI timing engine is ready to begin generating converts, as soon as it receives a Sample Clock (beginning of a sample). Once the Sample Clock Timebase domain has received a valid Start Trigger, the AI timing engine is ready to begin generating Sample Clocks.

Figure B-9. Convert Clock Timebase Timing and the Analog Input Timing Engine

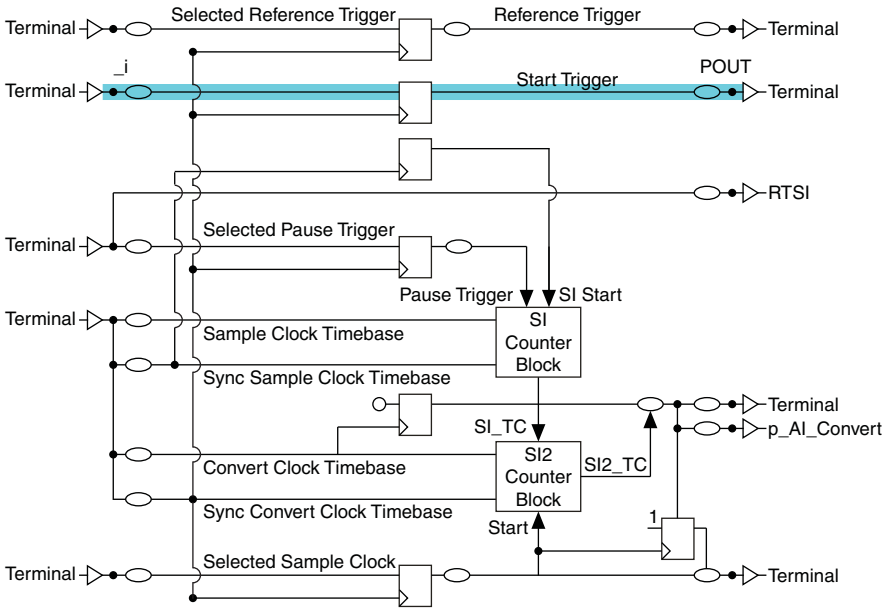

Figure B-10. Convert Clock Timebase Timing Diagram

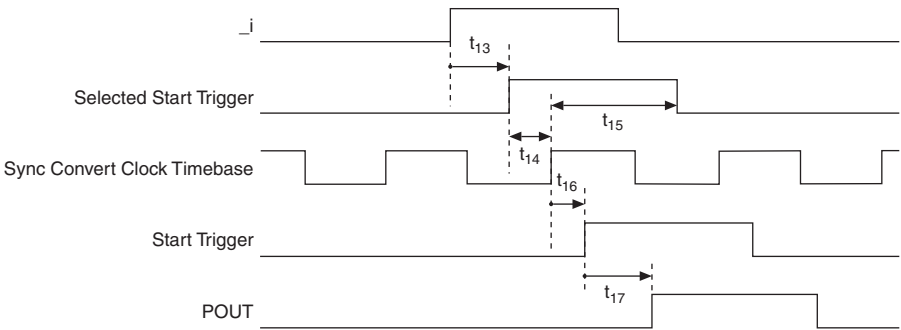

Table B-5. Convert Clock Timebase Timing

Time	Description	Line	Min (ns)	Max (ns)
t ₁₃	Delay to Selected Start Trigger	PFI	3.4	8.8
		RTSI	3.3	8.5
		STAR	2.7	5.7
t ₁₄	Selected Start Trigger Setup Time (to Sync Convert Clock Timebase)	—	1.5	—
t ₁₅	Selected Start Trigger Hold Time (to Sync Convert Clock Timebase)	—	0	—
t ₁₆	Sync Convert Clock Timebase to Start Trigger	—	0.9	2.4
t ₁₇	Start Trigger to POUT	PFI	1.1	3.1
		RTSI	1.1	2.7

Figure B-11. Sample Clock Timebase Timing and the Analog Input Timing Engine

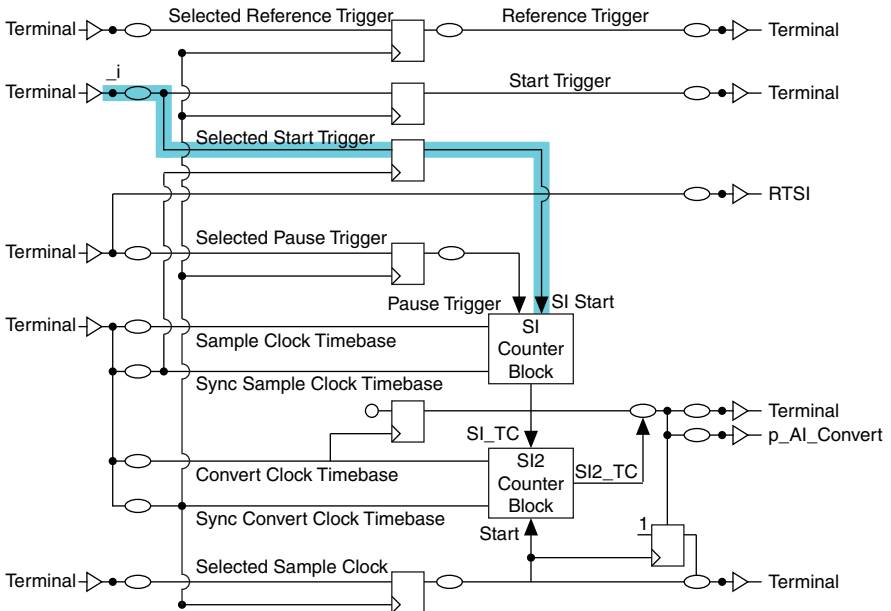

Figure B-12. Sample Clock Timebase Timing Diagram

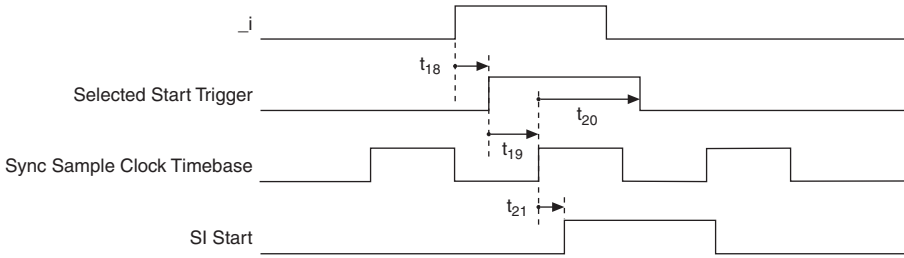

Table B-6. Sample Clock Timebase Timing

Time	Description	Line	Min (ns)	Max (ns)
t_{18}	Delay to Selected Start Trigger	PFI	3.4	8.8
		RTSI	3.3	8.5
		STAR	2.7	5.7
t_{19}	Selected Start Trigger Setup/Hold Time (to Sync Sample Clock Timebase)	—	1.5	—
t_{20}	Selected Start Trigger Setup/Hold Time (to Sync Sample Clock Timebase)	—	0	—
t_{21}	Sync Sample Clock Timebase to SI_Start	—	0.9	2.2

Reference Trigger

Use the Reference Trigger to stop the acquisition. It is normally used in pretrigger acquisitions; it is necessary to acquire data before and after the trigger. The Reference Trigger signals the time when the AI timing engine starts counting the number of posttrigger conversions to take before stopping. The Reference Trigger can come from external or internal sources and its source is selected with a multiplexer. Its output is called the Selected Reference Trigger. Its output is called the Selected Reference Trigger.

Figure B-13. Reference Trigger and the Analog Input Timing Engine

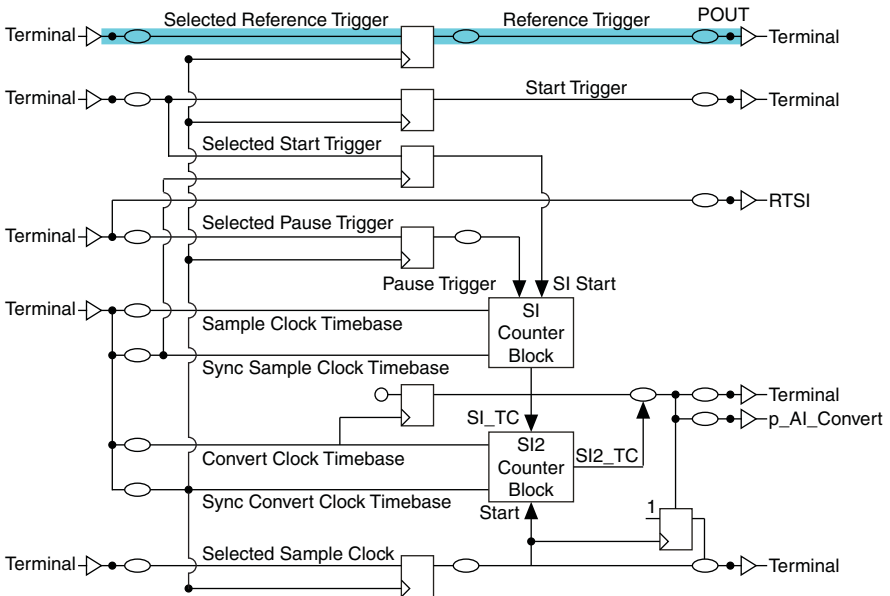

Figure B-14. Reference Trigger Timing Diagram

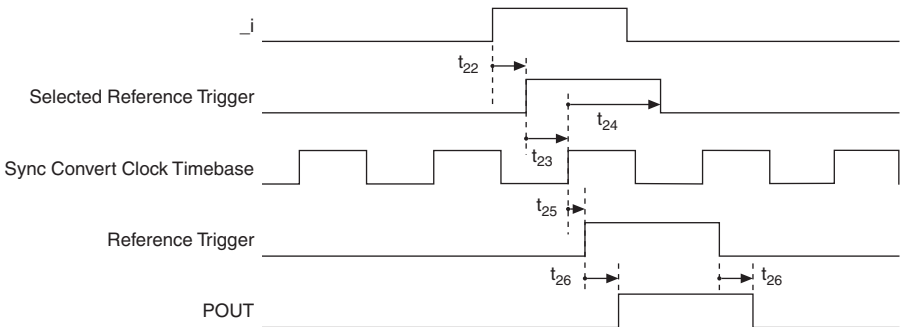

Table B-7. Reference Trigger Timing

Time	Description	Line	Min (ns)	Max (ns)
t_{22}	Delay to the Selected Reference Trigger	PFI	3.6	8.9
		RTSI	3.4	8.4
		STAR	2.9	5.6
t_{23}	Selected Reference Trigger Setup (to Sync Convert Clock Timebase)	—	1.5	—
t_{24}	Selected Reference Trigger Hold (to Sync Convert Clock Timebase)	—	0	—
t_{25}	Sync Convert Clock Timebase to Reference Trigger	—	0.9	2.2
t_{26}	Reference Trigger to POUT	PFI	0.8	2.3
		RTSI	0.8	1.9

Sample Clock

Sample Clock signals the start of a sample (which, in turn, is a set of converts). Sample Clock is generated from external or internal sources. The main internal source is the terminal count (TC) of the SI counter that runs on the Sample Clock Timebase signal. All the sources for Sample Clock are at the `_i` level and are selected using a multiplexer. The output of this multiplexer is called Selected Sample Clock.

Figure B-15. Sample Clock and the Analog Input Timing Engine

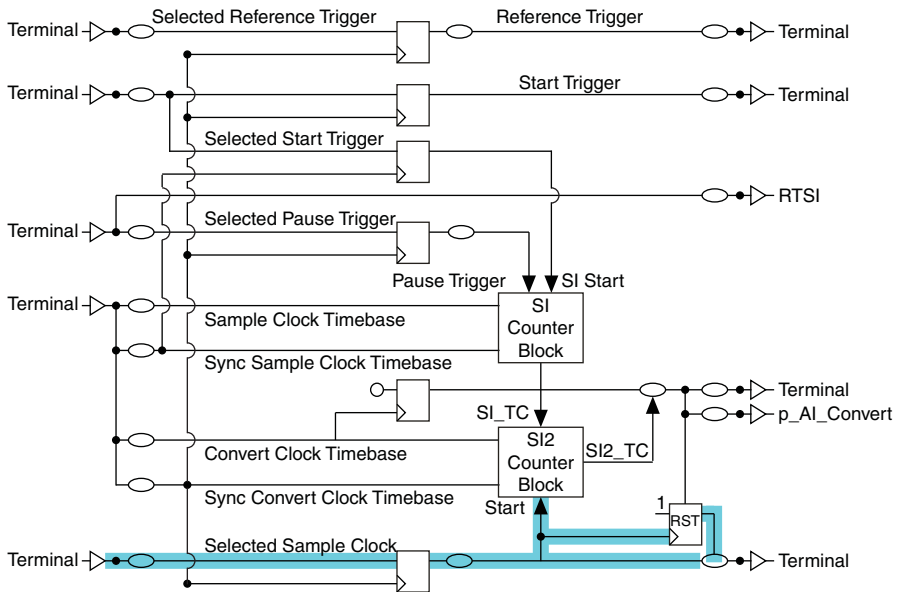

Figure B-16. Sample Clock Timing Diagram

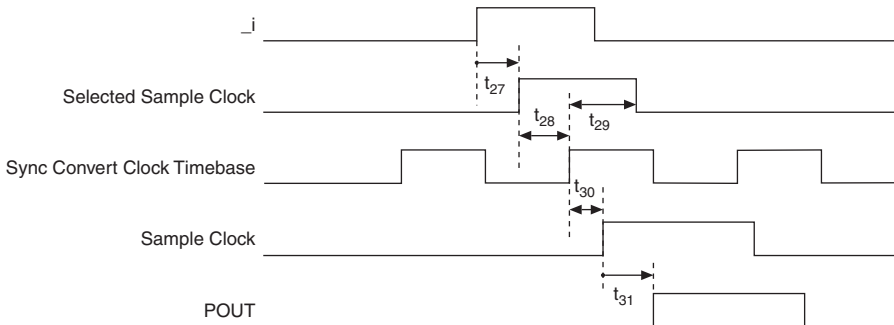

Table B-8. Sample Clock Timing

Time	Description	Line	Min (ns)	Max (ns)
t ₂₇	Delay to Selected Sample Clock	PFI	3.5	8.9
		RTSI	3.4	8.6
		STAR	2.8	5.9
t ₂₈	Selected Sample Clock Setup time (to Sync Convert Clock Timebase)	—	1.5	—
t ₂₉	Selected Sample Clock Hold time (to Sync Convert Clock Timebase)	—	0	—
t ₃₀	Sync Convert Clock Timebase to Sample Clock	—	2.4	5.8
t ₃₁	Sample Clock to POUT	PFI	2.4	5.5
		RTSI	3.2	6.8

The AI timing engine also can export a signal related to the Sample Clock called AI_Sample_In_Progress. This signal asserts with the Sample Clock and stays asserted until after the last convert of the sample. It is useful for external simultaneous sample and hold signal conditioning.

Figure B-17. AI_Sample_In_Progress Timing Diagram

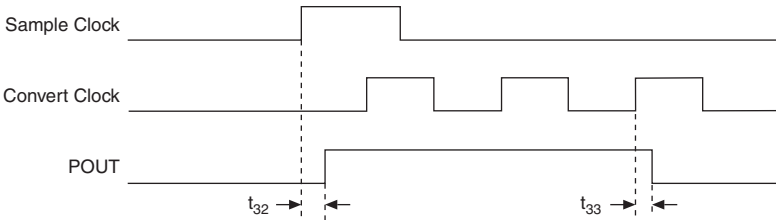

Table B-9. AI_Sample_In_Progress Timing

Time	Description	Line	Min (ns)	Max (ns)
t ₃₂	Sample Clock to POUT as leading edge of AI_Sample_In_Progress	PFI	3.4	8.0
		RTSI	4.2	9.2
t ₃₃	Convert Clock to POUT as trailing edge of AI_Sample_In_Progress	PFI	5.4	12.4
		RTSI	6.2	13.6

Pause Trigger

The Pause Trigger signal can be used to pause the acquisition any time the signal deasserts. It is generated from internal or external sources. A multiplexer selects a signal from the `_i` bus; its output is called Selected Pause Trigger.

Figure B-18. Pause Trigger and the Analog Input Timing Engine

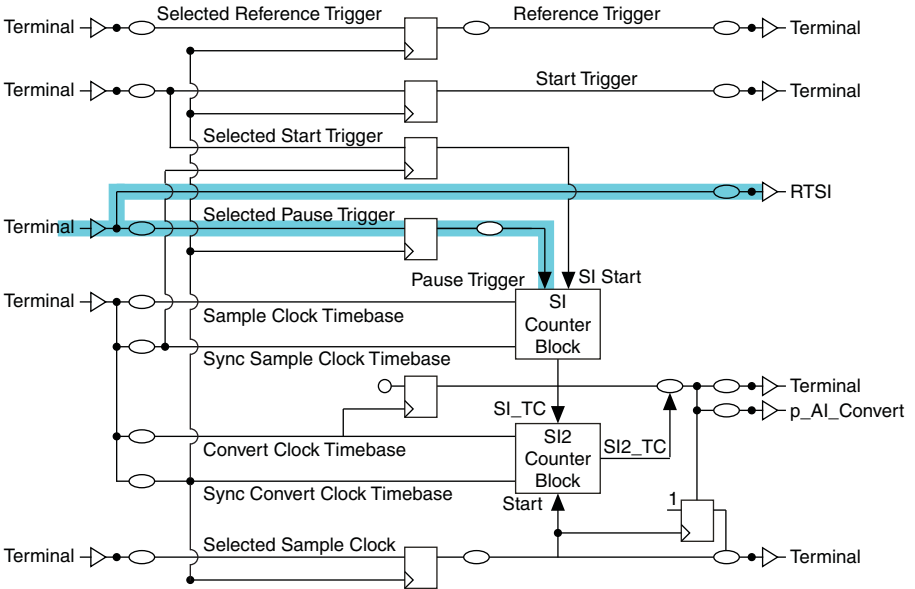

Figure B-19. Pause Trigger Timing Diagram

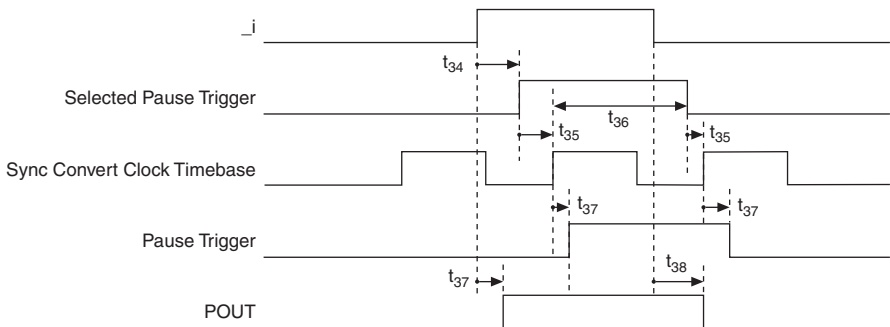

Table B-10. Pause Trigger Timing

Time	Description	Line	Min (ns)	Max (ns)
t ₃₄	_i to Selected Gate	PFI	3.2	7.8
		RTSI	3.0	7.5
		STAR	2.5	4.9
t ₃₅	Selected Pause Trigger Setup Time (to Sync Convert Clock Timebase)	—	1.5	—
t ₃₆	Hold (Sync Convert Clock Timebase)	—	0	—
t ₃₇	Sync Convert Clock Timebase to Pause Trigger	—	0.6	2.6
t ₃₈	Pause Trigger Source in _i to POUT	RTSI	1.1	3.1

Output Timing

Output timing refers to the delays involved in exporting internal signals to external terminals, so they can be used to trigger or time external devices. These timing parameters include the selection multiplexer in each terminal plus the delay of the output driver. Figures B-20 and B-21 and Table B-11 describe output timing.

The delays presented in this section assume a 200 pF load on PFI lines and a 50 pF load on RTSI lines. Actual delays vary with the actual load.

Figure B-20. Output Timing and the Analog Input Timing Engine

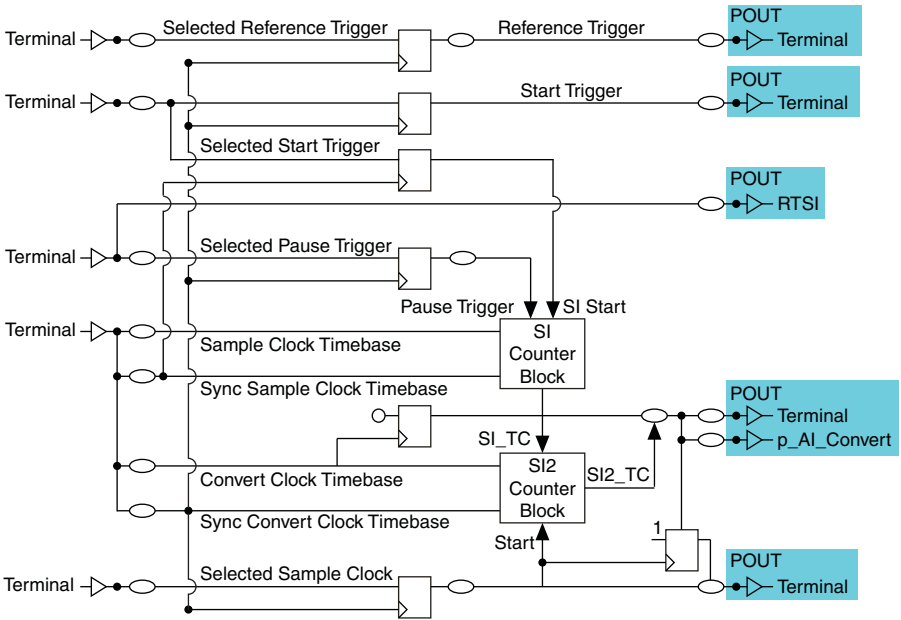

Figure B-21. Output Timing Diagram

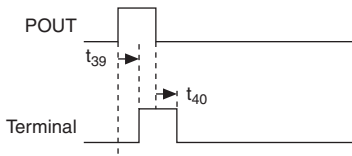

Table B-11. Output Timing

Edge	Line	Min (ns)	Max (ns)
Rising Edge	PFI	7.2	25.7
	RTSI	5.6	14.0
Falling Edge	PFI	7.5	25.9
	RTSI	6.0	13.9

Analog Output Timing Diagrams

The analog output timing can be broken into the following three sections:

- **Input Timing**—The timing for external signals to enter the M Series device and be available on the internal signal buses.
- **Internal Analog Output Timing**—The timing specifications of the analog output unit itself, to and from internal signals.
- **Output Timing**—The timing of exported signals going to the M Series device external terminals.

Figure B-22 gives an overview of analog output timing.

Figure B-22. M Series Analog Output Timing

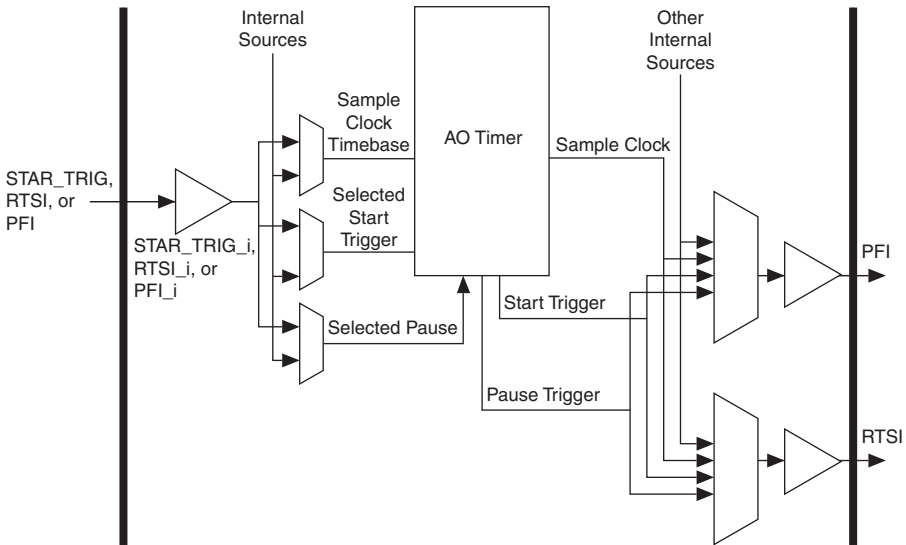

The following signals are used in Figure B-22 and in the following sections:

- **Sample Clock**—This signal multiplied by the digital to analog conversions. This signal is routed to the DAC, and in every pulse, the DAC will perform a data conversion. This signal can come directly from an external signal or can be the result of dividing down the Sample Clock Timebase using the UI counter.
- **Sample Clock Timebase**—This signal can be used to generate the Sample Clock. This signal acts as the clock for the UI counter, and a Sample Clock can be generated every N periods of the Sample Clock Timebase by programming the UI counter accordingly. This signal can come from an internal source (such as the board oscillator) or an external source.
- **Sync Sample Clock Timebase**—The Sync Sample Clock Timebase is a signal that is generated internally and is related to the Sample Clock Timebase. How it is generated and

the relationship between the two signals depends on the mode of operation. In general, the Sync Sample Clock Timebase is used to synchronize the input signals to the analog output timing engine before they are used by the Sample Clock Timebase.

- **Start Trigger and Selected Start Trigger**—The Start Trigger determines when a timed analog output operation will begin. This signal can come from a software command or an external pulse. Selected Start Trigger is the output of the selection block for the Start Trigger source.
- **Pause Trigger and Selected Pause**—The waveform generation can be paused using the pause trigger. When enabled, the waveform generation will occur as long as the gate is enabled. The generation will be paused if the gate is disabled. This signal can come from a software command or an external signal. The Selected Pause is the output of the selection block for the Pause Trigger source.
- **Star_Trig, RTSI, or PFI**—These terminals are the I/O interface for the device. All external triggers are input on these terminals. Internal signals can be exported to these terminals as well.
- **_i Signals**—All signals marked with `_i` are external signals that have been through the I/O buffers and are ready for internal use.

Input Timing

Input timing refers to the delays of importing signals from the external terminals so that the analog output timing engine can use them as sources for different triggers or clocks. Figure B-23 and Table B-12 describe the insertion delays for external signals.

Figure B-23. Input Timing Diagram

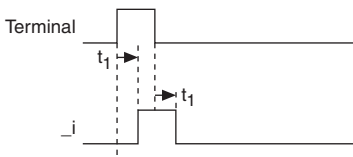

Table B-12. Input Timing

Time	From	To	Min (ns)		Max (ns)	
t_1^*	PFI	PFI_i	4.1	6.4	15.2	19.2
	RTSI	RTSI_i	0.9	2.2	2.0	3.0
	STAR	STAR_i	0.9	—	—	2.8

* The delay ranges given for PFI and RTSI represent the fastest and slowest terminal routing within the trigger group for a given condition (maximum or minimum timing). This difference can be useful when two external signals will be used together and the relative timing between the signals is important.

Internal Analog Output Timing

The analog output timer has two internal clocks that are referenced—Sample Clock Timebase and Sync Sample Clock Timebase. How they are generated depends on how the analog output timer is configured. If the analog output timing engine is configured to operate with an external Sample Clock, analog output internal clock timing can be derived from Table B-13.

Figure B-24. External Update Source Clock Insertions Timing Diagram

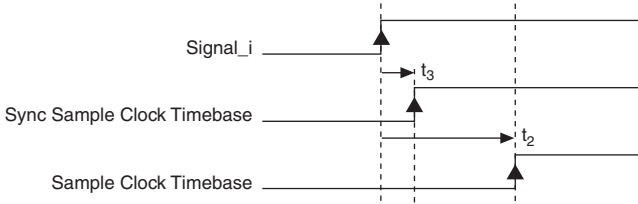

Table B-13. External Update Source Clock Insertions Timing

Time	From	To	Min (ns)	Max (ns)
t_2	Signal_i	Sample Clock Timebase	11.6	30.0
t_3	Signal_i	Sync Sample Clock Timebase	1.5	7.0

If the Sample Clock is being generated by dividing down the Sample Clock Timebase, the analog output generation is timed from the output of the UI counter. The signal Sample Clock Timebase can be an external signal. When the analog output timing engine operates in this mode, it is assumed that the source signal for the Sample Clock timebase is a free-running clock, so the Sync Sample Clock Timebase is the inverted version of Sample Clock Timebase. Configuring the analog output timing engine for rising edge operation will cause the external signals to be synchronized on the falling edge of the Sample Clock Timebase, which corresponds to the rising edge of Sync Sample Clock Timebase.

Figure B-25. Sample Clock Timebase and the Sync Sample Clock Timebase Timing Diagram

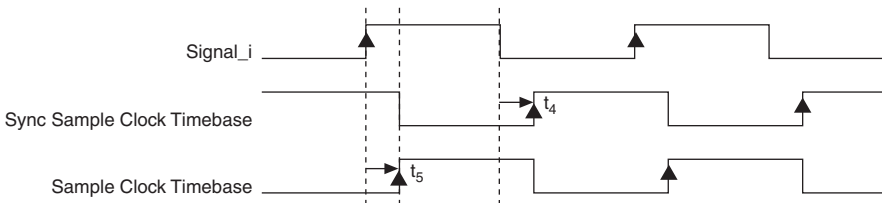
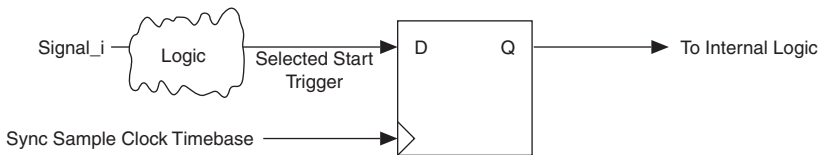
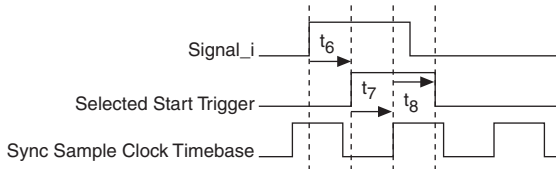

Table B-14. Sample Clock Timebase and the Sync Sample Clock Timebase Timing

Time	From	To	Min (ns)	Max (ns)
t_4	Signal_i	Sample Clock Timebase	2.4	9.3
t_5	Signal_i	Sync Sample Clock Timebase	2.4	9.3

Start Trigger

As an output, the Start Trigger is routed as an asynchronous pulse. The actual signal that gets routed is the Selected Start Trigger signal, so there is no synchronous delay involved.

Figure B-26. Start Trigger Input Delay Path**Figure B-27.** Start Trigger Timing Diagram**Table B-15.** Start Trigger Timing from Signal_i to Selected Start Trigger

Time	From	To	Min (ns)	Max (ns)
t_6	Signal_i	Selected Start Trigger	2.9	9.8

Table B-16. Start Trigger Setup and Hold Timing

Time	Parameter	Min (ns)	Max (ns)
t_7	Setup	1.5	—
t_8	Hold	0	—

Pause Trigger

The analog output Pause Trigger can be used to pause an ongoing generation. It is received on the rising edge of Sync Sample Clock Timebase.

Figure B-28. Pause Trigger Input Delay Path

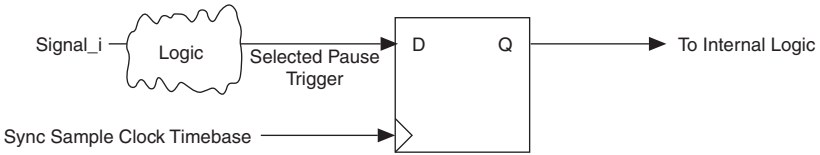

Figure B-29. Pause Trigger Timing Diagram

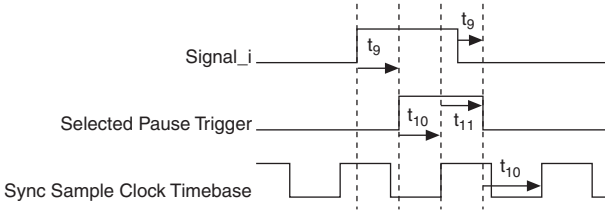

Table B-17. Pause Trigger Timing from Signal_i to Selected Pause Trigger

Time	From	To	Min (ns)	Max (ns)
t_9	Signal_i	Selected Pause Trigger	1.7	7.8

Table B-18. Pause Trigger Setup and Hold Timing

Time	Parameter	Min (ns)	Max (ns)
t_{10}	Setup	1.5	—
t_{11}	Hold	0	—

Input Timing Verification

Consider an application that uses an external trigger and an external clock. The trigger and clock signals are routed to an internal D flip-flop (DFF). To ensure that the trigger is sampled on a particular clock edge, the setup and hold times of the internal DFF must be met:

- Recall that a “terminal” is a PFI pin, RTSI pin, or PXI_Star pin.
- Let TriggerDelay be the delay from the trigger terminal to the DFF.
- Let ClockDelay be the delay from the clock terminal to the DFF.
- Let DFF_{Setup} and DFF_{Hold} be the setup and hold time of the DFF.
- Let $External_{Setup}$ and $External_{Hold}$ be the setup and hold time of the trigger to the clock at the terminals.

Figure B-30 shows the external trigger and external clock and the trigger delay and clock delay.

Figure B-30. External Trigger and External Clock Application

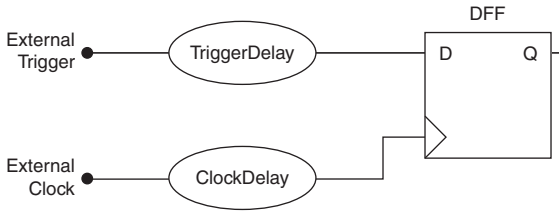

To satisfy the DFF setup and hold requirement, the following condition must be true:

$$\text{External}_{\text{Setup}} \geq \text{DFF}_{\text{Setup}} - \text{ClockDelay} + \text{TriggerDelay}$$

$$\text{External}_{\text{Hold}} \geq \text{DFF}_{\text{Hold}} + \text{ClockDelay} - \text{TriggerDelay}$$

$\text{DFF}_{\text{Setup}}$ and DFF_{Hold} are given by Table B-16 for AO Start Trigger and Table B-18 for AO Pause triggers.

ClockDelay is the sum of the input timing, shown in Table B-12, and insertion timing, shown in Table B-13.

TriggerDelay is the sum of the input timing, shown in Table B-12, and internal timing, shown in Tables B-15 and B-17.

For setup calculations, use the maximum timing parameters. For hold calculations, use the minimum timing parameters.

For input timing, as shown in Table B-12, two numbers are given for the maximum delay and two numbers for the minimum delay. In order to account for the worst case skew between different input terminals, use the range given in the input delay tables in the *Input Timing* section in a way that provides the most conservative results. For setup calculations, use the bigger number for TriggerDelay and the smaller number ClockDelay. For hold calculations, use the smaller number for TriggerDelay and the larger number for ClockDelay.

Output Timing

The analog output timer has three possible trigger outputs—Start Trigger, Pause Trigger, and Sample Clock. The delays presented in this section assume a 200 pF load on PFI lines and a 50 pF load on RTSI lines. Actual delays will vary with the actual load. The two numbers given for each condition represent the variation from the best case and worst case terminals.

- **Start Trigger**—As an output, the Start Trigger is routed as an asynchronous pulse. The actual signal that gets routed is the Selected Start Trigger signal, so there is no synchronous delay involved.

Figure B-31. Start Trigger Path

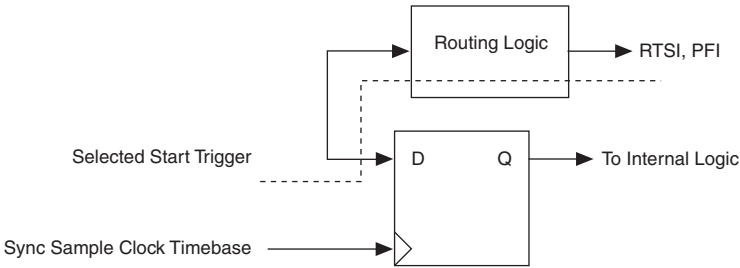

Figure B-32. Start Trigger Output Delay Timing Diagram

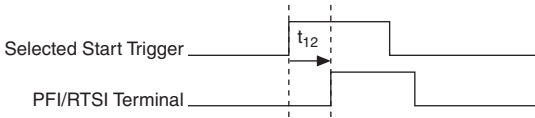

Table B-19. Start Trigger Output Delay Timing

Time	From	To	Min (ns)		Max (ns)	
t_{12}	Selected Start Trigger	PFI	8.1	9.1	27.1	30.8
	Selected Start Trigger	RTSI	7.5	7.7	17.9	18.5

- Pause Trigger**—Pause Trigger is only output asynchronously and only to RTSI. The actual signal being routed is Selected Pause. The Pause Trigger output timing can be derived by adding the delay in Table B-20 to the total Selected Pause delay.

Figure B-33. Pause Trigger Path

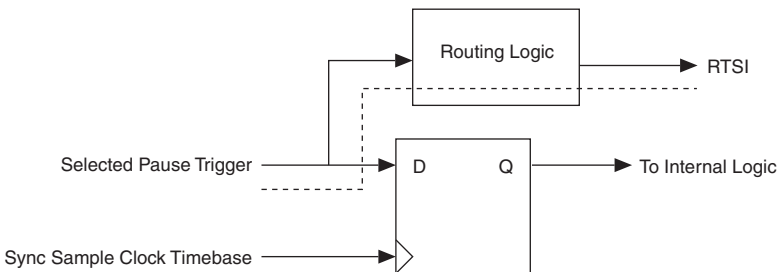
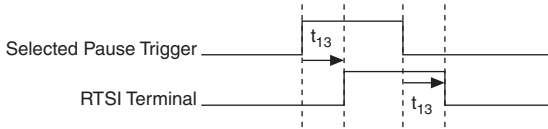
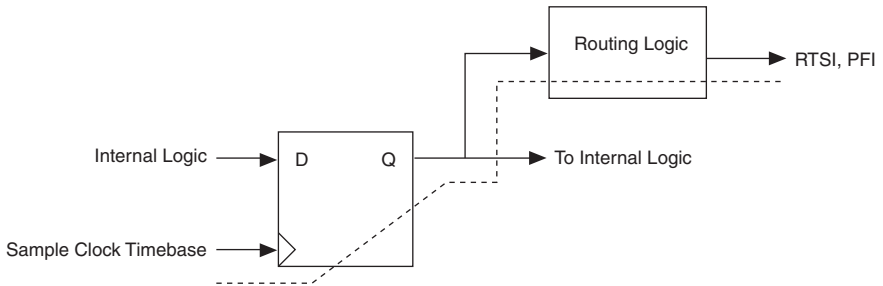
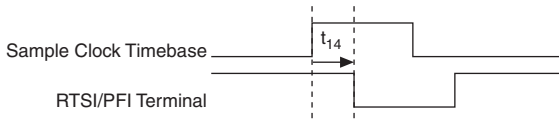

Figure B-34. Pause Trigger Output Routing Delay Timing Diagram**Table B-20.** Pause Trigger Output Routing Delay Timing

Time	From	To	Min (ns)		Max (ns)	
t_{13}	Selected Pause Trigger	RTSI	6.7	7.1	16.3	17.0

- Sample Clock**—The rising edge of the Sample Clock is output synchronous to the Sample Clock Timebase. It can be calculated by adding the Sample Clock Timebase insertion to the delay in Table B-21. The exported Sample Clock signal is active low, each falling edge representing a conversion.

Figure B-35. Sample Clock Path**Figure B-36.** Sample Clock Delay Timing Diagram**Table B-21.** Sample Clock Delay Timing

Time	From	To	Min (ns)		Max (ns)	
t_{14}	AO Sample Clock	PFI	9.7	10.7	31.1	34.3
	AO Sample Clock	RTSI	8.8	9.1	21.3	21.7

Digital I/O Timing Diagrams

This section describes the timing delays and requirements of digital waveform acquisitions and digital waveform generations.

Digital Waveform Acquisition Timing

To describe digital waveform acquisition timing delays and requirements, refer to the circuitry shown in Figure B-37. In the figure, P0, PFI, RTSI, and PXI_STAR represent signals at connector pins of the M Series device. The other named signals represent internal signals.

Figure B-37. Digital Waveform Acquisition Timing Circuitry

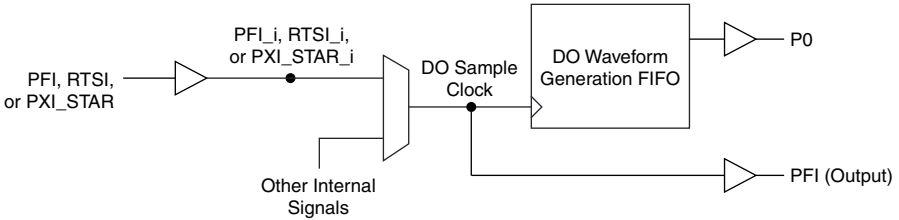

Figure B-38 and Tables B-22 and B-23 describe the digital waveform acquisition timing delays and requirements. Your inputs must meet the requirements to ensure proper behavior.

Figure B-38. Digital Waveform Acquisition Timing Delays

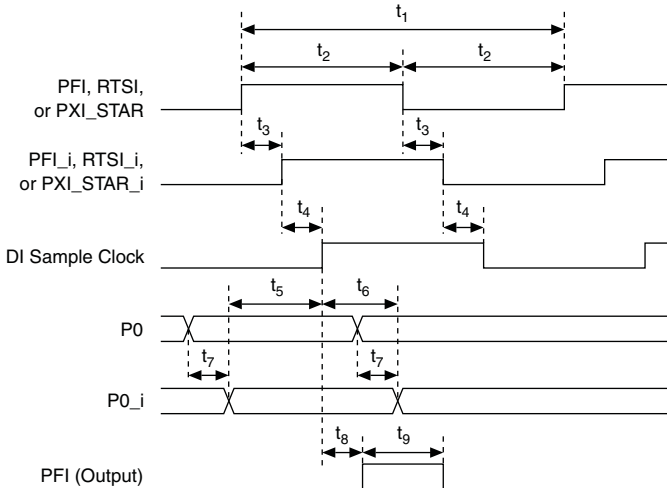

Table B-22. DI Timing Delays

Time	From	To	Min (ns)		Max (ns)	
t_3^*	PFI	PFI_i	5.2	6.2	18.2	22.0
	RTSI	RTSI_i	2.0	2.5	5.0	6.0
	PXI_STAR	PXI_STAR_i	1.5		3.5	
t_4	PFI_i, RTSI_i, PXI_STAR_i, or other internal signal	DI Sample Clock	3.5		9	
t_7	P0	P0_i	4.7		20.1	
t_8	DI Sample Clock	PFI (output)	8.0		29.8	
t_9^\dagger	PFI (output) high	PFI (output) low	One period of 80 MHz Timebase		Two periods of 80 MHz Timebase	
<p>* The delay ranges given for PFI and RTSI represent the fastest and slowest terminal routing within the trigger group for a given condition (maximum or minimum timing). This difference can be useful when two external signals will be used together and the relative timing between the signals is important.</p> <p>† When DI Sample Clock is routed to a PFI output pin, the pulse width of the output is independent of the pulse width of the input. The pulse width is specified in a number of periods of the 80 MHz Timebase</p>						

Table B-23. DI Timing Requirements

Time	Requirement	Condition	Min (ns)	Max (ns)
t_1	PFI, RTSI, or PXI_STAR minimum period	When used as DI Sample Clock	NI 622x devices: 1000.0 NI 625x/628x devices: 100.0	—
t_2	PFI, RTSI, or PXI_STAR minimum pulse width	When used as DI Sample Clock	12.0	—
t_5	Setup time from P0_i to DI Sample Clock	—	1.5	—
t_6	Hold time from DI Sample Clock to P0_i	—	0	—

Digital Waveform Generation Timing

To describe digital waveform generation timing delays and requirements, we model the circuitry as shown in Figure B-39. In the figure, P0, PFI, RTSI, and PXI_STAR represent signals at connector pins of the M Series device. The other named signals represent internal signals.

Figure B-39. Digital Waveform Generation Timing Circuitry

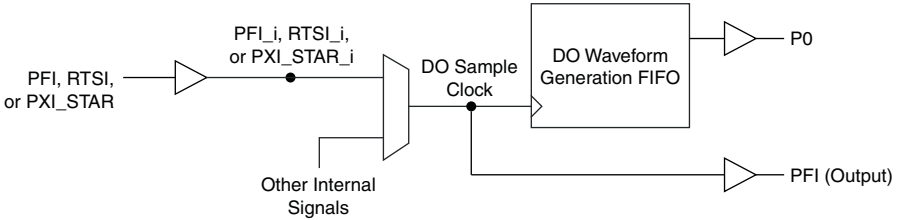

Figure B-40 and Tables B-24 and B-25 describe the digital waveform generation timing delays and requirements. Your inputs must meet the requirements to ensure proper behavior.

Figure B-40. Digital Waveform Acquisition Timing Delays

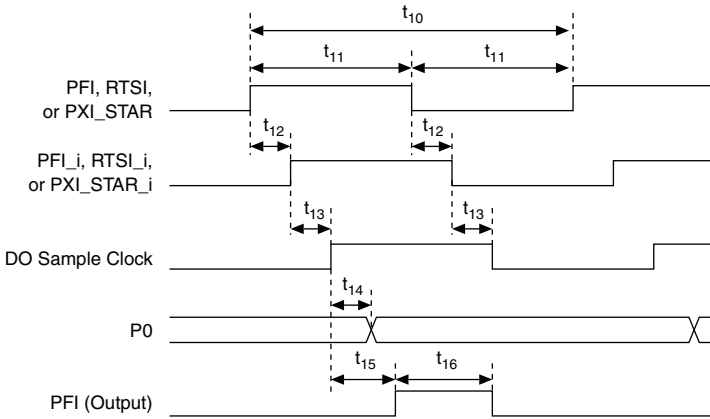

Table B-24. DO Timing Delays

Time	From	To	Min (ns)		Max (ns)	
t_{12}^*	PFI	PFI_i	5.2	6.2	18.2	22.0
	RTSI	RTSI_i	2.0	2.5	5.0	6.0
	PXI_STAR	PXI_STAR_i	1.5		3.5	
t_{13}	PFI_i, RTSI_i, PXI_STAR_i, or other internal signal	DO Sample Clock	3.5		9.5	

Table B-24. DO Timing Delays (Continued)

Time	From	To	Min (ns)	Max (ns)
t_{14}	DO Sample Clock	P0	7.5	27.5
t_{15}	DO Sample Clock	PFI (output)	8.0	29.8
t_{16}^{\dagger}	PFI (output) high	PFI (output) low	Two periods of 80 MHz Timebase	Three periods of 80 MHz Timebase

* The delay ranges given for PFI and RTSI represent the fastest and slowest terminal routing within the trigger group for a given condition (maximum or minimum timing). This difference can be useful when two external signals will be used together and the relative timing between the signals is important.

\dagger When DO Sample Clock is routed to a PFI output pin, the pulse width of the output is independent of the pulse width of the input. The pulse width is specified in a number of periods of the 80 MHz Timebase.

Table B-25. DO Timing Requirements

Time	Requirement	Condition	Min (ms)	Max (ms)
t_{10}	PFI, RTSI, or PXI_STAR minimum period	When used as DO Sample Clock	NI 622x devices: 1000.0 NI 625x/NI 628x devices: 100.0	—
t_{11}	PFI, RTSI, or PXI_STAR minimum pulse width	When used as DO Sample Clock	12.0	—

Counters Timing Diagrams

This section describes input delays, input requirements, output delays, gating modes, and quadrature and two pulse encoder timing.

Input Delays

This section describes some of the timing delays of the counter/timer circuit. To describe delays of the counter/timer, we model the circuitry as shown in Figure B-41. In the figure, PFI, RTSI, and PXI_STAR represent signals at connectors pins of the M Series device. The other named signals represent internal signals.

Figure B-41. Counter/Timer Circuitry

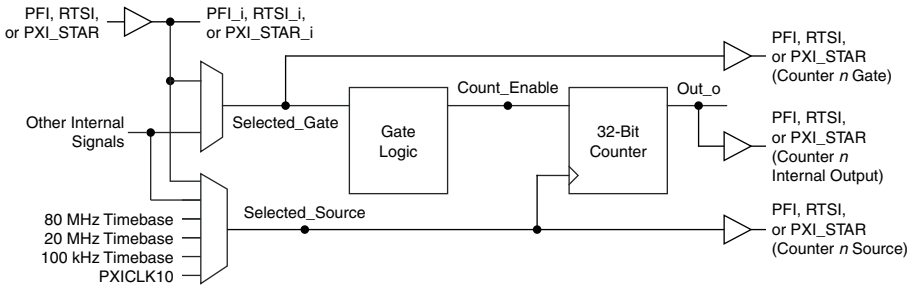

Pin to Internal Signal Delays

Input timing is the timing specification for importing a signal to an internal bus on the M Series device. Table B-26 shows the input timing for the counters on all input terminals. Signals refer to the signal at the I/O connector of the device, and signals appended with *_i* refer to the signal internal to the device after the input buffer.

Figure B-42. Pin to Internal Signal Delays Timing Diagram

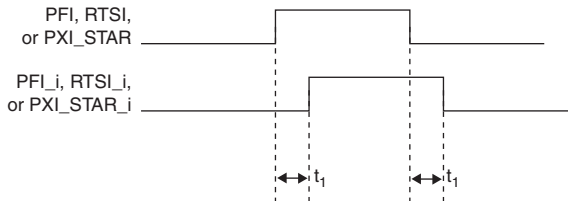

Table B-26. Pin to Internal Signal Delays Timing

Time	From	To	Min (ns)		Max (ns)	
t_1^*	PFI	PFI_i	5.2	6.2	18.2	22.0
	RTSI	RTSI_i	2.0	2.5	5.0	6.0
	STAR	STAR_i	0.9	—	—	2.5

* The delay ranges given for PFI and RTSI represent the fastest and slowest terminal routing within the trigger group for a given condition (maximum or minimum timing). This difference can be useful when two external signals will be used together and the relative timing between the signals is important.

Selected Gate and Selected Source Delays

Tables B-27 and B-28 show the timing for the Selected Source and Selected Gate internal signals.

Selected Source is used to clock the 32-bit counter. Selected Gate drives the Gate Logic, which generates the Counter Enable signal.

All internal counter timing is referenced to these two signals. Any internal signal refers to signals with `_i` from the previous table or signals coming from another subsystem inside the M Series device. It does not include internal timebases or the `PXI_CLK10`.

Figure B-43. Selected Gate Delays Timing Diagram

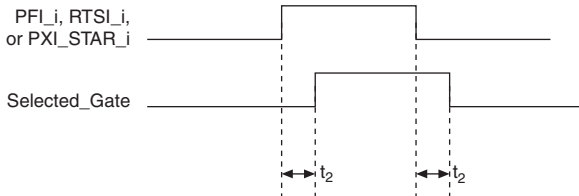

Table B-27. Selected Gate Delays Timing

Time	From	To	Min (ns)	Max (ns)
t_2	PFI_i, RTSI_i, PXI_STAR_i, or any internal signal	Selected Gate	1.0	6.0

Figure B-44. Selected Source Delays Timing Diagram

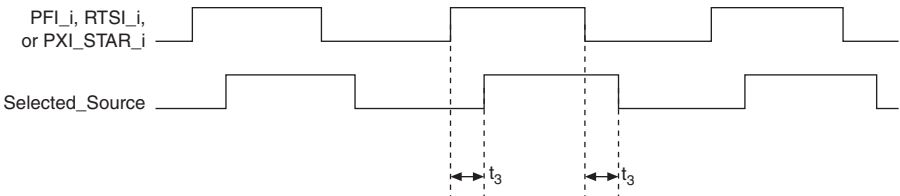

Table B-28. Selected Source Delays Timing

Time	From	To	Min (ns)	Max (ns)
t ₃	PFI_i, RTSI_i, PXI_STAR_i, or any internal signal	Selected Source	8.0	21.0
	20 MHz Timebase	Selected Source	1.5	4.0
	100 kHz Timebase	Selected Source	1.5	4.0
	80 MHz Timebase	Selected Source	1.0	2.5
	PXI_CLK10	Selected Source	1.0	3.5

Count Enable Delay

Table B-29 shows timing for the internal Count Enable signal, as shown in Figure B-41. Count Enable enables the 32-bit counter to count on the rising edge of the Selected Source signal.

The delays depend on both the synchronization mode and gating mode for the application.

Figure B-45. Count Enable Delays



Table B-29. Selected Gate to Count Enable Delays

Time	Synchronization Mode	Gating Mode	Min (ns)	Max (ns)
t_4	80 MHz Source	Edge	0.5	5.0
		Level	-1.0	0.5
	Other Internal Source	Edge	1/2 Source Period - 1 ns	1/2 Source Period + 3 ns
		Level	1/2 Source Period - 2.5 ns	1/2 Source Period - 1 ns
	External Source	Edge	7.5	22.0
		Level	6.0	18.0

Input Requirements

Refer to the Figure B-41 for the M Series counter/timer circuitry.

Source Period and Pulse Width

Figure B-46 and Table B-30 show the timing requirements for Counter n Source. The requirements depend on the synchronization mode.

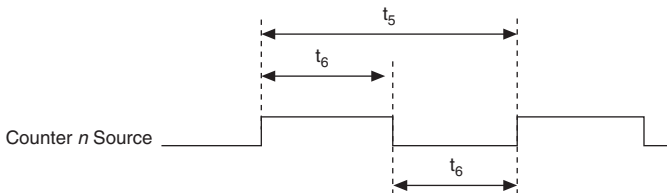
Figure B-46. Counter n Source Timing Requirements**Table B-30.** Counter n Source Timing

Time	Description	Synchronization Mode	Min (ns)*	Max (ns)
t_5	Counter n Source Period	80 MHz Source	12.5	—
		Other Internal Source	25.0	—
		External Source	50.0	—

Table B-30. Counter *n* Source Timing (Continued)

Time	Description	Synchronization Mode	Min (ns)*	Max (ns)
t_6	Counter <i>n</i> Source Pulse Width	80 MHz Source	6.2	—
		Other Internal Source	12.5	—
		External Source	16.0	—

* The times in this table are measured at the pin of the M Series device. For example, t_5 specifies the minimum period of a signal driving a PFI, RTSI, or PXI_STAR pin when that signal is internally routed to Counter *n* Source.

Gate Pulse Width

Figure B-47 and Table B-31 show the timing requirements for Counter *n* Gate. The requirements depend on the gating mode.

Figure B-47. Counter *n* Gate Pulse Width Timing Diagram

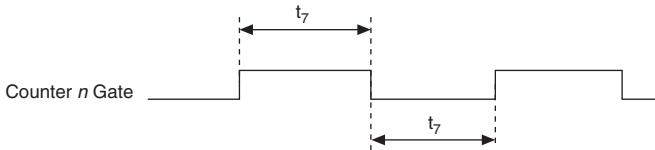

Table B-31. Counter *n* Gate Pulse Width Timing

Time	Description	Gating Mode	Min (ns)*	Max (ns)
t_7	Counter <i>n</i> Gate Pulse Width	Edge	12.0	—
	Counter <i>n</i> Gate Pulse Width	Level	One Source Period	—

* The times in this table are measured at the pin of the M Series device. That is, t_7 specifies the minimum pulse width of a signal driving a PFI, RTSI, or PXI_STAR pin when that signal is internally routed to Counter *n* Gate.

Gate to Source Setup and Hold

The counter can be modeled as a set of flip flops where the D input is Count Enable and the clock input is Selected Source, as shown in Figure B-41. This section shows the setup and hold requirements for two different cases:

- A PFI pin drives Counter *n* Source and a different PFI pin drives Counter *n* Gate
- The general case (all other combinations of signals driving Source and Gate)

Figure B-48 and Table B-32 show the setup and hold requirements at the PFI pins for the first case (where a PFI pin drives Counter n Source and a different PFI pin drives Counter n Gate).

Figure B-48. Gate to Source Setup and Hold Timing Diagram

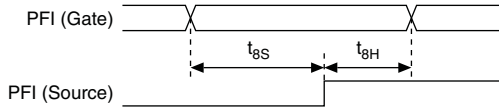

Table B-32. Gate to Source Setup and Hold Timing

Time	Description	Gating Mode	Synchronization Mode	Min (ns)	Max (ns)
t_{8S}	Setup time from PFI (Gate) to PFI (Source)	Edge	External Source	12.3	—
		Level	External Source	8.3	—
t_{8H}	Hold time from PFI (Gate) to PFI (Source)	Edge	External Source	0.5	—
		Level	External Source	2.0	—

Figure B-49 and Table B-33 show the setup and hold requirements of the internal block of the DAQ-STC2. Use the table to calculate the setup and hold times for your Source and Gate signals for the general case. In the general case, you can determine whether the setup and hold requirements are met by adding up the various delays of the appropriate signals through the counter/timer circuit.

Figure B-49. DAQ-STC2 Internal Block Setup and Hold Requirements Timing Diagram

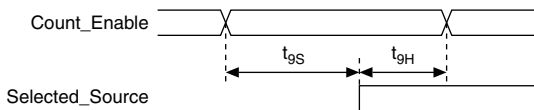

Table B-33. DAQ-STC2 Internal Block Setup and Hold Requirements Timing

Time	Parameter	Min (ns)	Max (ns)
t_{9S}	Setup	1.5	—
t_{9H}	Hold	0	—

Example of the General Case

Calculate the setup and hold time requirements when the Gate and Source come from PFI lines and the Gate is used in level mode.



Note This example shows how we determine the setup and hold times for the PFI to PFI example above (first case) using level gating.

Setup

To calculate the setup time, subtract the Source delay from the Gate delay. Use maximum delays.

Gate Delay	
PFI to PFI _i	22.0 ns
PFI _i to Selected Gate	6.0 ns
Selected Gate to Count Enable (Level)	18.0 ns
Count Enable Setup Time	+ 1.5 ns
	47.5 ns
Source Delay	
PFI to PFI _i	18.2 ns
PFI _i to Selected Source	+ 21.0 ns
	39.2 ns

$$T_{\text{Setup}} > 47.5 \text{ ns} - 39.2 \text{ ns} = 8.3 \text{ ns}$$

Hold

To calculate the hold time, subtract the Gate delay from the Source delay. Use minimum delays.

Gate Delay	
PFI to PFI _i	5.2 ns
PFI _i to Selected Gate	1.0 ns
Selected Gate to Count Enable (Level)	6.0 ns
Count Enable Hold Time	+ 0.0 ns
	12.2 ns
Source Delay	
PFI to PFI _i	6.2 ns
PFI _i to Selected Source	+ 8.0 ns
	14.2 ns

$$T_{\text{Hold}} > 14.2 \text{ ns} - 12.2 \text{ ns} = 2.0 \text{ ns}$$

Output Delays

Refer to the Figure B-41 for the M Series counter/timer circuitry.

Figure B-50 and Table B-34 show the output delays.

Figure B-50. Output Delays

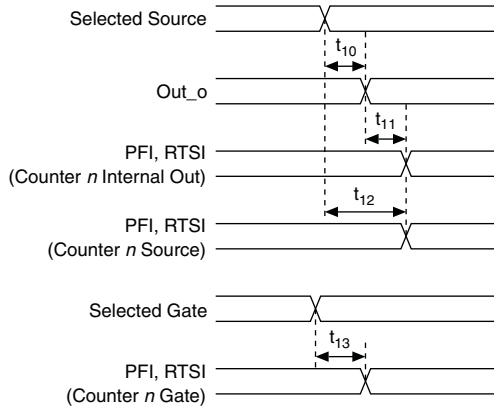

Table B-34. Output Delays Timing

Time	Line	Min (ns)	Max (ns)
t_{10}	—	1.0	4.0
t_{11}	PFI	7.5	28.2
	RTSI	6.5	18.0
t_{12}	PFI	8.5	32.2
	RTSI	7.5	22.0
t_{13}	PFI	7.5	28.7
	RTSI	6.5	18.0

Gating Modes

Gating mode refers to how the counter/timer uses the Gate input. Some timing operations depend on the gating mode. Depending on the application, the counter/timers either level gating mode or edge gating mode.

In NI-DAQmx, the counter/timers use level gating mode for the following measurements:

- Edge counting
- Pulse width measurements
- Two-signal edge separation measurements

All other measurements use edge gating mode.

Quadrature and Two Pulse Encoder Timing

Counter *n* A, Counter *n* B, and Counter *n* Z, described in the *Counter n A, Counter n B, and Counter n Z Signals* section of Chapter 7, *Counters*, are used in position measurements using quadrature encoder or two-pulse encoder counting modes. Table B-35 shows the timing requirements for these signals.

Figure B-51. Quadrature and Two Pulse Encoder Timing Diagrams

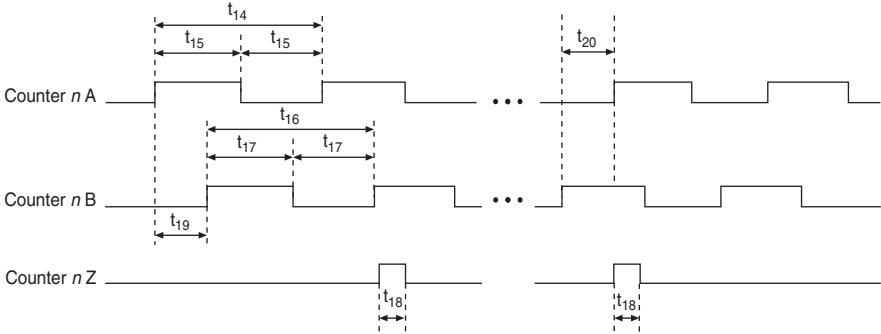

Table B-35. Quadrature and Two Pulse Encoder Timing

Time	Description	Min (ns)*	Max (ns)
t_{14}	Counter <i>n</i> A Period	50.0	—
t_{15}	Counter <i>n</i> A Pulse Width	25.0	—
t_{16}	Counter <i>n</i> B Period	50.0	—
t_{17}	Counter <i>n</i> B Pulse Width	25.0	—
t_{18}	Counter <i>n</i> Z Pulse Width	25.0	—
t_{19}	Delay from Counter <i>n</i> A to Counter <i>n</i> B	25.0	—
t_{20}	Delay from Counter <i>n</i> B to Counter <i>n</i> A	25.0	—

* The times in this table are measured at the pin of the M Series device. For example, t_{14} specifies the minimum period of a signal driving a PFI, RTSI, or PXI_STAR pin when that signal is internally routed to Counter *n* A.

Clock Generation Timing Diagrams

Table B-36 shows delays for generating different clocks, described in the [Clock Routing](#) section of Chapter 9, [Digital Routing and Clock Generation](#), from the onboard 80 MHz oscillator.

Figure B-52. Generating Different Clocks from the Onboard 80 MHz Oscillator

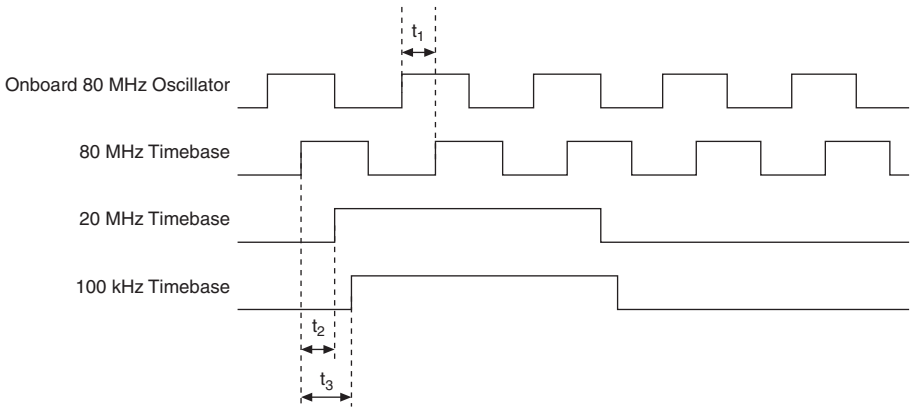

Table B-36. Generating Different Clocks from the Onboard 80 MHz Oscillator

Time	From	To	Min (ns)	Max (ns)
t_1	Onboard 80 MHz Oscillator	80 MHz Timebase	4.0	9.0
t_2	80 MHz Timebase	20 MHz Timebase	0.5	2.5
t_3	80 MHz Timebase	100 kHz Timebase	1.0	5.0

Table B-37 shows delays for generating different clocks using an External Reference Clock and the PLL.

Figure B-53. Generating Different Clocks Using an External Reference Clock and the PLL

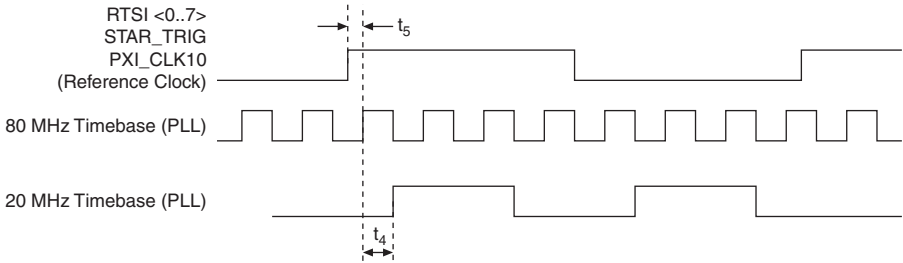

Table B-37. Generating Different Clocks Using an External Reference Clock and the PLL

Time	From	To	Min (ns)	Max (ns)
t_4	80 MHz Timebase	20 MHz Timebase	1.5	5.0
t_5	The source of the external reference clock (RTSI <0..7>, STAR_TRIG, PXI_CLK10)	80 MHz Timebase (through PLL_OUT)	1.0	5.5

Troubleshooting

This section contains common questions about M Series devices. If your questions are not answered here, refer to the National Instruments KnowledgeBase at ni.com/kb.

Analog Input

I am seeing crosstalk, or ghost voltages, when sampling multiple channels. What does this mean?

You may be experiencing a phenomenon called charge injection, which occurs when you sample a series of high-output impedance sources with a multiplexer. Multiplexers contain switches, usually made of switched capacitors. When a channel, for example AI 0, is selected in a multiplexer, those capacitors accumulate charge. When the next channel, for example AI 1, is selected, the accumulated current (or charge) leaks backward through channel 1. If the output impedance of the source connected to AI 1 is high enough, the resulting reading can somewhat affect the voltage in AI 0. To circumvent this problem, use a voltage follower that has operational amplifiers (op-amps) with unity gain for each high-impedance source before connecting to an M Series device. Otherwise, you must decrease the sample rate for each channel.

Another common cause of channel crosstalk is due to sampling among multiple channels at various gains. In this situation, the settling times can increase. For more information about charge injection and sampling channels at different gains, refer to the *Multichannel Scanning Considerations* section of Chapter 4, *Analog Input*.

I am using my device in differential analog input ground-reference mode and I have connected a differential input signal, but my readings are random and drift rapidly. What is wrong?

In DIFF mode, if the readings from the DAQ device are random and drift rapidly, you should check the ground-reference connections. The signal can be referenced to a level that is considered floating with reference to the device ground reference. Even if you are in DIFF mode, you must still reference the signal to the same ground level as the device reference. There are various methods of achieving this reference while maintaining a high common-mode rejection ratio (CMRR). These methods are outlined in the *Connecting Analog Input Signals* section of Chapter 4, *Analog Input*.

AI GND is an AI common signal that routes directly to the ground connection point on the devices. You can use this signal if you need a general analog ground connection point to the device. Refer to the *When to Use Differential Connections with Ground-Referenced Signal Sources* section of Chapter 4, *Analog Input*, for more information.

How can I use the AI Sample Clock and AI Convert Clock signals on an M Series device to sample the AI channel(s)?

M Series devices use AI Sample Clock (ai/SampleClock) and AI Convert Clock (ai/ConvertClock) to perform interval sampling. As Figure C-1 shows, AI Sample Clock controls the sample period, which is determined by the following equation:

$$1/\text{sample period} = \text{sample rate}$$

Figure C-1. AI Sample Clock and AI Convert Clock

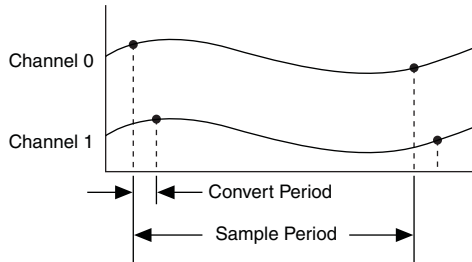

AI Convert Clock controls the convert period, which is determined by the following equation:

$$1/\text{convert period} = \text{convert rate}$$

This method allows multiple channels to be sampled relatively quickly in relationship to the overall sample rate, providing a nearly simultaneous effect with a fixed delay between channels.

Analog Output

I am seeing glitches on the output signal. How can I minimize it?

When you use a DAC to generate a waveform, you may observe glitches on the output signal. These glitches are normal; when a DAC switches from one voltage to another, it produces glitches due to released charges. The largest glitches occur when the most significant bit of the DAC code changes. You can build a lowpass deglitching filter to remove some of these glitches, depending on the frequency and nature of the output signal. Visit ni.com/support for more information about minimizing glitches.

Counters

When multiple sample clocks on my buffered counter measurement occur before consecutive edges on my source, I see weird behavior. Why?

Duplicate count prevention ensures that the counter returns correct data for counter measurement in some applications where a slow or non-periodic external source is used.

Refer to the *Duplicate Count Prevention* section of Chapter 7, *Counters*, for more information.

How do I connect counter signals to my M Series device?

The *Default Counter/Timer Pinouts* section of Chapter 7, *Counters*, has information about counter signal connections.

M Series Installation Issues

My M Series device is not detected by Measurement & Automation Explorer (MAX) or the Windows 2000/NT/XP operating system. When using other devices (such as E Series devices) on the same PC, they work fine. What is the problem?

Appendix D, *Upgrading from E Series to M Series*, lists issues encountered when upgrading from E Series to M Series devices.

Customers also can refer to NI's KnowledgeBase at ni.com/kb for more updated troubleshooting tips and answers to frequently asked questions about M Series devices.

Upgrading from E Series to M Series

This appendix supplies information about the differences between M Series and E Series multifunction I/O families.

M Series and E Series Pinout Comparison

The pinout of Connector 0 of 68-pin M Series devices is similar to the pinout of 68-pin E Series devices. On M Series devices, some terminals have enhanced functionality or other slight differences. Table D-1 compares the two pinouts.

Table D-1. M Series and E Series Device Pinout Comparison

E Series Signal*	M Series Signal	Differences
FREQ OUT	PFI 14/P2.6	E Series devices drive each of these terminals with one particular internal timing signal.
CTR 0 OUT (GPCTR0_OUT)	PFI 12/P2.4	M Series devices can drive each terminal with the same signal as on E Series devices. On M Series devices, you also can route many other internal timing signals to each terminal.
CTR 1 OUT (GPCTR1_OUT)	PFI 13/P2.5	
EXT STROBE	PFI 10/P2.2	
AI HOLD COMP (SCANCLK)	PFI 11/P2.3	
PFI 9/CTR 0 GATE (GPCTR0_GATE)	PFI 9/P2.1	As a PFI input, the functionality of E Series and M Series devices is similar for these terminals.
PFI 6/AO START TRIG (WFTRIG)	PFI 6/P1.6	E Series devices can drive each of these terminals with one particular internal timing signal.
PFI 5/AO SAMP CLK (UPDATE)	PFI 5/P1.5	M Series devices can drive each terminal with the same signal as on E Series devices. On M Series devices, you also can route many other internal timing signals to each terminal.
PFI 1/AI REF TRIG (TRIG2)	PFI 1/P1.1	
PFI 8/CTR 0 SRC (GPCTR0_SOURCE)	PFI 8/P2.0	On M Series devices, you also can use these terminals as digital I/O signals.
PFI 7/AI SAMP CLK (STARTSCAN)	PFI 7/P1.7	Also refer to Chapter 8, PFI .
PFI 4/CTR 1 GATE (GPCTR1_GATE)	PFI 4/P1.4	
PFI 3/CTR 1 SRC (GPCTR1_SOURCE)	PFI 3/P1.3	
PFI 2/AI CONV CLK (CONVERT)	PFI 2/P1.2	

Table D-1. M Series and E Series Device Pinout Comparison (Continued)

E Series Signal*	M Series Signal	Differences
PFI 0/AI START TRIG (TRIG1)	PFI 0/P1.0	<p>On E Series devices, as an input, this terminal can either be a PFI input or the analog trigger input.</p> <p>On M Series devices, as an input, this terminal can only be a PFI input. Analog triggers use the APFI <0,1> terminals.</p> <p>E Series devices can drive this terminal with the AI START TRIG signal.</p> <p>M Series devices, as an output, can drive this terminal with the AI START TRIG signal. You also can route many other internal timing signals to this terminal.</p> <p>On M Series devices, you also can use this terminal as the digital I/O signal, P1.0.</p> <p>Also refer to Chapter 8, PFI.</p>
P0.6	P0.6	<p>On both E Series and M Series devices, these terminals are digital I/O signals. You can individually configure each signal as an input or output.</p>
P0.7	P0.7	<p>On E Series devices, P0.6 and P0.7 also can control the up/down signal of general-purpose Counters 0 and 1, respectively.</p> <p>On M Series devices, you have to use one of the PFI terminals to control the up/down signal of general-purpose Counters 0 and 1.</p>
AO EXT REF (EXTREF)	APFI 0	<p>On E Series devices, this terminal is the external reference input for the AO circuitry.</p> <p>On M Series devices, this terminal can be used as the external reference input for the AO circuitry, the external offset for the AO circuitry, or the analog trigger input. These functions are not available on all devices. Refer to the specifications for your device.</p> <p>Note that this terminal is a no connect on some E Series and M Series devices.</p>
D GND	PFI 15/P2.7	<p>On E Series devices, this is one of the D GND terminals. On M Series devices, this is the PFI 15/P2.7 terminal.</p>
<p>* In NI-DAQmx, National Instruments has revised terminal names so they are easier to understand and more consistent among National Instruments hardware and software products. This column shows the NI-DAQmx terminal names (Traditional NI-DAQ (Legacy) terminal names are shown in parentheses).</p>		

More Information about Upgrading to M Series

The following documents will help you overcome typical hurdles in upgrading from E Series to M Series devices:

- *Major Differences Between E Series and M Series DAQ Devices* KnowledgeBase lists the advantages of M Series over E Series and the functional differences and other differences between the two DAQ device families. To access this KnowledgeBase, go to ni.com/info and enter the Info Code `rdmess`.
- *Migrating an Application from E Series to M Series* Developer Zone document highlights the main differences to remember when moving an application from E Series to M Series devices. To access this document, go to ni.com/info and enter the Info Code `rdem1`.
- *Using E Series Accessories with M Series Devices* KnowledgeBase describes how to use 68-pin E Series accessories with M Series devices. To access this KnowledgeBase, go to ni.com/info and enter the Info Code `rdea2m`.
- *M Series or S Series Devices Are Not Detected During Installation on Some Computers* KnowledgeBase describes the difference between M Series and E Series power rails, and the PCI specification for the PCI bus and power rails, and contains an up-to-date list of computers with power rails that do not support M Series devices. To access this KnowledgeBase, go to ni.com/info and enter the Info Code `rdmseis`.

Where to Go from Here

This section lists where you can find example programs for the M Series devices and modules and relevant documentation.

Example Programs

NI-DAQmx software includes example programs to help you get started programming with M Series devices and modules. Modify example code and save it in an application, or use examples to develop a new application, or add example code to an existing application.

To locate NI software examples, go to ni.com/info and enter the Info Code `daqmxexp`. For additional examples, refer to ni.com/examples.

To run examples without the device installed, use an NI-DAQmx simulated device. For more information, in Measurement & Automation Explorer (MAX), select **Help»Help Topics»NI-DAQmx»MAX Help for NI-DAQmx** and search for simulated devices.

Related Documentation

Each application software package and driver includes information about writing applications for taking measurements and controlling measurement devices. The following references to documents assume you have NI-DAQmx 15.5 or later.

M Series Documentation

DAQ Getting Started Guide for PXI/PXI Express, *DAQ Getting Started Guide for PCI/PCI Express*, or *DAQ Getting Started Guide for Externally Powered USB*, packaged with your device or module, and also available on ni.com/manuals, show you how to install your software and device or module. They also describe how to confirm that your device or module is operating properly, configure your device or module, run test panels, and take a measurement.

The *NI 62xx Specifications* lists all specifications for your M Series device or module. Go to ni.com/manuals and search for your device.

The *B/E/M/S/X Series Calibration Procedure* contains information for calibrating your multifunction I/O device. Go to ni.com/manuals.

NI-DAQmx for Windows

The *NI-DAQmx Readme* lists which devices, ADEs, and NI application software are supported by this version of NI-DAQmx.

The *NI-DAQmx Help* contains API overviews, general information about measurement concepts, key NI-DAQmx concepts, and common applications that are applicable to all programming environments.

NI-DAQmx for Linux

The *DAQ Getting Started* guides for your device describe how to install your NI-DAQmx-supported DAQ device/module and confirm that your device is operating properly.

The *NI-DAQ Readme for Linux* lists supported devices and modules and includes software installation instructions, frequently asked questions, and known issues.

The *C Function Reference Help* describes functions and attributes.

The *NI-DAQmx for Linux Configuration Guide* provides configuration instructions, templates, and instructions for using test panels.



Note All NI-DAQmx documentation for Linux is installed at `/usr/local/natinst/nidaqmx/docs`.



Note USB-622x/625x/628x devices are *not* supported in NI-DAQmx for Linux.

NI-DAQmx Base (Linux/Mac OS X)

The *NI-DAQmx Base Getting Started Guide* describes how to install your NI-DAQmx Base software, your NI-DAQmx Base-supported DAQ device, and how to confirm that your device is operating properly.

Getting Started with NI-DAQmx Base for Linux and Mac Users describes how to install your NI-DAQmx Base software, your NI-DAQmx Base-supported DAQ device, and how to confirm that your device is operating properly on your Mac/Linux machine.

The *NI-DAQmx Base Readme* lists which devices are supported by this version of NI-DAQmx Base.

The *NI-DAQmx Base VI Reference Help* contains VI reference and general information about measurement concepts.

The *NI-DAQmx Base C Reference Help* contains C reference and general information about measurement concepts.



Note All NI-DAQmx Base documentation for Linux is installed at `/usr/local/natinst/nidaqmxbase/documentation`.



Note All NI-DAQmx Base documentation for Mac OS X is installed at `/Applications/National Instruments/NI-DAQmx Base/documentation`.



Note USB-622x/625x/628x devices are *not* supported in NI-DAQmx Base.

LabVIEW

Refer to ni.com/gettingstarted for more information about LabVIEW.

Use the *LabVIEW Help*, available by selecting **Help»LabVIEW Help** in LabVIEW, to access information about LabVIEW programming concepts, step-by-step instructions for using LabVIEW, and reference information about LabVIEW VIs, functions, palettes, menus, and tools. Refer to the following locations on the **Contents** tab of the *LabVIEW Help* for information about NI-DAQmx:

- **VI and Function Reference»Measurement I/O VIs and Functions»DAQmx - Data Acquisition VIs and Functions**—Describes the LabVIEW NI-DAQmx VIs and functions.
- **Property and Method Reference»NI-DAQmx Properties**—Contains the property reference.
- **Taking Measurements**—Contains the conceptual and how-to information you need to acquire and analyze measurement data in LabVIEW, including common measurements, measurement fundamentals, NI-DAQmx key concepts, and device considerations.

LabVIEW Real-Time

Refer to ni.com/gettingstarted for more information about getting started with LabVIEW Real-Time.

The *Real-Time Module Concepts* book of the *LabVIEW Real-Time Module Help* includes conceptual information about real-time programming techniques, application architectures, and Real-Time Module features you can use to create real-time applications. Refer to the Real-Time Module concepts before attempting to create a deterministic real-time application.

LabWindows/CVI

The **Data Acquisition** book of the *LabWindows/CVI Help* contains *Taking an NI-DAQmx Measurement in LabWindows/CVI*, which includes step-by-step instructions about creating a measurement task using the DAQ Assistant. In LabWindows/CVI, select **Help»Contents**, then select **Using LabWindows/CVI»Data Acquisition**. This book also contains information about accessing detailed information through the *NI-DAQmx Help*.

The **NI-DAQmx Library** book of the *LabWindows/CVI Help* contains API overviews and function reference for NI-DAQmx. Select **Library Reference»NI-DAQmx Library** in the *LabWindows/CVI Help*.

Measurement Studio

If you program your NI-DAQmx-supported device in Measurement Studio using Visual C# or Visual Basic .NET, you can interactively create channels and tasks by launching the DAQ Assistant from MAX or from within Visual Studio. You can use Measurement Studio to generate

the configuration code based on your task or channel. Refer to the *DAQ Assistant Help* for additional information about generating code.

The *NI Measurement Studio Help* is fully integrated with the Microsoft Visual Studio help. To view this help file from within Visual Studio, select **Measurement Studio»NI Measurement Studio Help**. For information related to developing with NI-DAQmx, refer to the following topics within the *NI Measurement Studio Help*:

- For step-by-step instructions on how to create an NI-DAQmx application using the Measurement Studio Application Wizard and the DAQ Assistant, refer to *Walkthrough: Creating a Measurement Studio NI-DAQmx Application*.
- For help with NI-DAQmx methods and properties, refer to the *NationalInstruments.DAQmx* namespace and the *NationalInstruments.DAQmx.ComponentModel* namespace.
- For conceptual help with NI-DAQmx, refer to *Using the Measurement Studio NI-DAQmx .NET Library* and *Creating Projects with Measurement Studio NI-DAQmx*.
- For general help with programming in Measurement Studio, refer to *Getting Started with the Measurement Studio Class Libraries*.

To create an NI-DAQmx application using Visual Basic .NET or Visual C#, follow these general steps:

1. In Visual Studio, select **File»New»Project** to launch the New Project dialog box.
2. Choose a programming language (Visual C# or Visual Basic .NET), and then select **Measurement Studio** to see a list of project templates.
3. Select **NI DAQ Windows Application**. You add DAQ tasks as part of this step. Choose a project type. You add DAQ tasks as a part of this step.

ANSI C without NI Application Software

The *NI-DAQmx Help* contains API overviews and general information about measurement concepts. Select **Start»All Programs»National Instruments»NI-DAQmx»NI-DAQmx Help**.

The *NI-DAQmx C Reference Help* describes the NI-DAQmx Library functions, which you can use with National Instruments data acquisition devices to develop instrumentation, acquisition, and control applications. Select **Start»All Programs»National Instruments»NI-DAQmx»Text-Based Code Support»NI-DAQmx C Reference Help**.

.NET Languages without NI Application Software

With the Microsoft .NET Framework, you can use NI-DAQmx to create applications using Visual C# and Visual Basic .NET without Measurement Studio. Refer to the *NI-DAQmx Readme* for specific versions supported.

Training Courses

If you need more help getting started developing an application with NI products, NI offers training courses. To enroll in a course or obtain a detailed course outline, refer to ni.com/training.

Technical Support on the Web

For additional support, refer to ni.com/support or ni.com/examples.



Note You can download these documents at ni.com/manuals.

Many DAQ specifications and user guides/manuals are available as PDFs. You must have Adobe Reader 7.0 or later (PDF 1.6 or later) installed to view the PDFs. Refer to the Adobe Systems Incorporated website at www.adobe.com to download Adobe Reader. Refer to the National Instruments Product Manuals Library at ni.com/manuals for updated documentation resources.

NI Services

NI provides global services and support as part of our commitment to your success. Take advantage of product services in addition to training and certification programs that meet your needs during each phase of the application life cycle; from planning and development through deployment and ongoing maintenance.

To get started, register your product at ni.com/myproducts.

As a registered NI product user, you are entitled to the following benefits:

- Access to applicable product services.
- Easier product management with an online account.
- Receive critical part notifications, software updates, and service expirations.

Log in to your MyNI user profile to get personalized access to your services.

Services and Resources

- **Maintenance and Hardware Services**—NI helps you identify your systems' accuracy and reliability requirements and provides warranty, sparing, and calibration services to help you maintain accuracy and minimize downtime over the life of your system. Visit ni.com/services for more information.
 - **Warranty and Repair**—All NI hardware features a one-year standard warranty that is extendable up to five years. NI offers repair services performed in a timely manner by highly trained factory technicians using only original parts at a NI service center.
 - **Calibration**—Through regular calibration, you can quantify and improve the measurement performance of an instrument. NI provides state-of-the-art calibration services. If your product supports calibration, you can obtain the calibration certificate for your product at ni.com/calibration.
- **System Integration**—If you have time constraints, limited in-house technical resources, or other project challenges, National Instruments Alliance Partner members can help. To learn more, call your local NI office or visit ni.com/alliance.

- **Training and Certification**—The NI training and certification program is the most effective way to increase application development proficiency and productivity. Visit ni.com/training for more information.
 - The Skills Guide assists you in identifying the proficiency requirements of your current application and gives you options for obtaining those skills consistent with your time and budget constraints and personal learning preferences. Visit ni.com/skills-guide to see these custom paths.
 - NI offers courses in several languages and formats including instructor-led classes at facilities worldwide, courses on-site at your facility, and online courses to serve your individual needs.
- **Technical Support**—Support at ni.com/support includes the following resources:
 - **Self-Help Technical Resources**—Visit ni.com/support for software drivers and updates, a searchable KnowledgeBase, product manuals, step-by-step troubleshooting wizards, thousands of example programs, tutorials, application notes, instrument drivers, and so on. Registered users also receive access to the NI Discussion Forums at ni.com/forums. NI Applications Engineers make sure every question submitted online receives an answer.
 - **Software Support Service Membership**—The Standard Service Program (SSP) is a renewable one-year subscription included with almost every NI software product, including NI Developer Suite. This program entitles members to direct access to NI Applications Engineers through phone and email for one-to-one technical support, as well as exclusive access to online training modules at ni.com/self-paced-training. NI also offers flexible extended contract options that guarantee your SSP benefits are available without interruption for as long as you need them. Visit ni.com/ssp for more information.
- **Declaration of Conformity (DoC)**—A DoC is our claim of compliance with the Council of the European Communities using the manufacturer’s declaration of conformity. This system affords the user protection for electromagnetic compatibility (EMC) and product safety. You can obtain the DoC for your product by visiting ni.com/certification.

For information about other technical support options in your area, visit ni.com/services, or contact your local office at ni.com/contact.

You also can visit the Worldwide Offices section of ni.com/niglobal to access the branch office websites, which provide up-to-date contact information, support phone numbers, email addresses, and current events.

Index

Symbols

+5 V power source, 3-5

Numerics

10 MHz reference clock, 9-2

100 kHz Timebase, 9-2

20 MHz Timebase, 9-2

37-pin devices

accessory options, 2-8

cabling options, 2-8

68-pin devices

accessory options, 2-3

cabling options, 2-3

80 MHz source mode, 7-36

80 MHz Timebase, 9-2

A

A/D converter, 4-2

accessories, 2-3

37-pin connector devices, 2-8

68-pin connector devices, 2-3

choosing for your device, 1-13

PCI/PCIe/PXI/PXIe-6251, A-30

PCI/PCIe/PXI/PXIe-6259, A-46

PCI/PXI-6220, A-3

PCI/PXI-6221 (68-pin), A-6

PCI/PXI-6225, A-16

PCI/PXI-6229, A-22

PCI/PXI-6250, A-28

PCI/PXI-6254, A-38

PCI/PXI-6255, A-40

PCI/PXI-6280, A-54

PCI/PXI-6281, A-56

PCI/PXI-6284, A-62

PCI/PXI-6289, A-64

PCI/XPI-6224, A-14

PCI-6221 (37-pin), A-12

USB-6221 BNC, A-10

USB-6221 Screw Terminal, A-8

USB-6225 Mass Termination, A-20

USB-6225 Screw Terminal, A-18

USB-6229 BNC, A-26

USB-6229 Screw Terminal, A-24

USB-6251 BNC, A-34

USB-6251 Mass Termination, A-36

USB-6255 Mass Termination, A-20,
A-44

USB-6259 BNC, A-50

USB-6259 Mass Termination, A-52

USB-6281 Mass Termination, A-60

USB-6289 Mass Termination, A-68

used with M Series, D-4

accuracy, analog triggers, 11-6

acquisitions

circular-buffered, 4-9

digital waveform, 6-3

double-buffered, 4-9

hardware-timed, 4-9

on-demand, 4-9

software-timed, 4-9

AI channels, sampling with AI Sample Clock
and AI Convert Clock, C-2

AI Convert Clock signal, 4-25

AI Convert Clock Timebase signal, 4-29

AI data acquisition methods, 4-9

AI FIFO, 4-2

AI Hold Complete Event signal, 4-29

AI Pause Trigger signal, 4-31

AI Reference Trigger signal, 4-30

AI Sample Clock signal, 4-23

AI Sample Clock Timebase signal, 4-25

AI Start Trigger signal, 4-29

AI timing signals, 4-21

ai/ConvertClock, 4-25

ai/ConvertClockTimebase, 4-29

ai/HoldCompleteEvent, 4-29

ai/PauseTrigger, 4-31

ai/ReferenceTrigger, 4-30

ai/SampleClock, 4-23

ai/SampleClockTimebase, 4-25

ai/StartTrigger, 4-29

analog

comparison event, routing, 11-3

comparison event, signal, 11-3

edge triggering, 11-3

- trigger actions, 11-3
- trigger types, 11-3
- triggering, 11-2
- analog edge triggering
 - with hysteresis, 11-4
- analog input, 4-1
 - channels, 11-2
 - charge injection, C-1
 - circuitry, 4-1
 - connecting signals, 4-11
 - connecting through I/O connector, 4-1
 - crosstalk when sampling multiple channels, C-1
 - data acquisitions, 4-9
 - methods, 4-9
 - differential, troubleshooting, C-1
 - getting started with applications in software, 4-32
 - ghost voltages when sampling multiple channels, C-1
 - ground-reference settings, 4-1
 - lowpass filter, 4-3
 - MUX, 4-1
 - range, 4-2
 - sampling channels with AI Sample Clock and AI Convert Clock, C-2
 - signals, 4-21
 - AI Convert Clock, 4-25
 - AI Convert Clock Timebase, 4-29
 - AI Hold Complete Event, 4-29
 - AI Pause Trigger, 4-31
 - AI Reference Trigger, 4-30
 - AI Sample Clock, 4-23
 - AI Sample Clock Timebase, 4-25
 - AI Start Trigger, 4-29
 - timing diagrams, B-1
 - timing signals, 4-21
 - triggering, 4-10
 - troubleshooting, C-1
- analog output, 5-1
 - circuitry, 5-1
 - connecting signals, 5-5
 - data generation methods, 5-3
 - fundamentals, 5-1
 - getting started with applications in software, 5-10
 - glitches on the output signal, 5-3
 - offset, 5-2
 - reference selection, 5-2
 - signals, 5-6
 - AO Pause Trigger, 5-7
 - AO Sample Clock, 5-8
 - AO Sample Clock Timebase, 5-9
 - AO Start Trigger, 5-6
 - timing diagrams, B-20
 - timing signals, 5-6
 - trigger signals, 5-5
 - triggering, 5-5
 - troubleshooting, C-2
- analog source, triggering, 11-2
- analog to digital converter, 4-2
- analog trigger, 11-2
 - accuracy, 11-6
 - actions, 11-3
 - improving accuracy, 11-6
- analog window triggering, 11-5
- ANSI C documentation, E-4
- AO FIFO, 5-1
- AO offset, 5-1
- AO offset and AO reference selection settings, 5-2
- AO Pause Trigger signal, 5-7
- AO reference selection, 5-1
- AO Sample Clock, 5-1
- AO Sample Clock signal, 5-8
- AO Sample Clock Timebase signal, 5-9
- AO Start Trigger signal, 5-6
- ao/PauseTrigger, 5-7
- ao/SampleClock, 5-8
- ao/StartTrigger, 5-6
- APFI terminals, 11-2
- applications
 - counter input, 7-1
 - counter output, 7-19
 - edge counting, 7-2
 - arm start trigger, 7-29
- avoiding scanning faster than necessary, 4-8

B

buffered

- edge counting, 7-3
- hardware-timed acquisitions, 4-9
- hardware-timed generations, 5-4
- period measurement, 7-6
- position measurement, 7-17
- pulse-width measurement, 7-4
- semi-period measurement, 7-7
- two-signal edge-separation measurement, 7-18

bus

- interface, 10-1
- RTSI, 9-4

C

C Series I/O module

- specifications, E-1

cable management, 1-8

cables, 2-3

- 37-pin connector devices, 2-8
- 68-pin connector devices, 2-3
- choosing for your device, 1-13
- custom, 2-7
- PCI/PCIe/PXI/PXIe-6251, A-30
- PCI/PCIe/PXI/PXIe-6259, A-46
- PCI/PXI-6220, A-3
- PCI/PXI-6221 (68-pin), A-6
- PCI/PXI-6224, A-14
- PCI/PXI-6225, A-16
- PCI/PXI-6229, A-22
- PCI/PXI-6250, A-28
- PCI/PXI-6254, A-38
- PCI/PXI-6255, A-40
- PCI/PXI-6280, A-54
- PCI/PXI-6281, A-56
- PCI/PXI-6284, A-62
- PCI/PXI-6289, A-64
- PCI-6221 (37-pin), A-12
- USB-6225 Mass Termination, A-20
- USB-6251 Mass Termination, A-36
- USB-6255 Mass Termination, A-44
- USB-6259 Mass Termination, A-52
- USB-6281 Mass Termination, A-60
- USB-6289 Mass Termination, A-68

calibration, 1-4

cascading counters, 7-30

Change Detection Event signal, 6-7

changing data transfer methods

- between DMA and IRQ, 10-2, 10-3
- between USB signal stream and programmed I/O, 10-3

channel

- scanning order, 4-7
- Z behavior, 7-16

channels

- analog input, 11-2
- sampling with AI Sample Clock and AI Convert Clock, C-2

charge injection, C-1

choosing frequency measurement, 7-11

circular-buffered acquisition, 4-9

clock

- 10 MHz reference, 9-2
- external reference, 9-2
- generation, 9-1
 - timing diagrams, B-41
- PXI, and trigger signals, 9-8
- routing, 9-1

CompactPCI, using with PXI, 10-4

configuring AI ground-reference settings in software, 4-6

connecting

- analog input signals, 4-11
- analog output signals, 5-5
- counter signals, C-3
- digital I/O signals, 6-8
- floating signal sources, 4-12
- ground-referenced signal sources, 4-17
- PFI input signals, 8-3

connections

- for floating signal sources, 4-17
- single-ended for floating signal sources, 4-17
- single-ended, RSE configuration, 4-17

connector

- information, 3-1
- PCI/PCIe/PXI/PXIe-6251 pinout, A-29
- PCI/PCIe/PXI/PXIe-6259 pinout, A-45
- PCI/PXI-6220 pinout, A-2

- PCI/PXI-6221 (68-pin) pinout, A-4
- PCI/PXI-6224 pinout, A-13
- PCI/PXI-6225 pinout, A-15
- PCI/PXI-6229 pinout, A-21
- PCI/PXI-6250 pinout, A-27
- PCI/PXI-6254 pinout, A-37
- PCI/PXI-6255 pinout, A-39
- PCI/PXI-6280 pinout, A-53
- PCI/PXI-6281 pinout, A-55
- PCI/PXI-6284 pinout, A-61
- PCI/PXI-6289 pinout, A-63
- PCI-6221 (37-pin) pinout, A-11
- RTSI, 3-7
- USB-6221 BNC pinout, A-9
- USB-6221 Screw Terminal pinout, A-7
- USB-6225 Mass Termination pinout, A-19
- USB-6225 Screw Terminal pinout, A-17
- USB-6229 BNC pinout, A-25
- USB-6229 Screw Terminal pinout, A-23
- USB-6251 BNC pinout, A-33
- USB-6251 Mass Termination pinout, A-35
- USB-6251 Screw Terminal pinout, A-31
- USB-6255 Mass Termination pinout, A-43
- USB-6255 Screw Terminal pinout, A-41
- USB-6259 BNC pinout, A-49
- USB-6259 Mass Termination pinout, A-51
- USB-6259 Screw Terminal pinout, A-47
- USB-6281 Mass Termination pinout, A-59
- USB-6281 Screw Terminal pinout, A-57
- USB-6289 Mass Termination pinout, A-67
- USB-6289 Screw Terminal pinout, A-65
- considerations
 - for field wiring, 4-21
 - for multichannel scanning, 4-6
 - for PXI, 10-3
- continuous pulse train generation, 7-21
- controller, DMA, 10-2
- controlling counting direction, 7-2
- count enable delay, B-34
- counter
 - input and output, 7-28
 - output applications, 7-19
 - terminals, default, 7-28
- Counter *n* A signal, 7-27
- Counter *n* Aux signal, 7-26
- Counter *n* B signal, 7-27
- Counter *n* Gate signal, 7-25
- Counter *n* HW Arm signal, 7-27
- Counter *n* Internal Output signal, 7-28
- Counter *n* Source signal, 7-24
- Counter *n* TC signal, 7-28
- Counter *n* Up_Down signal, 7-27
- Counter *n* Z signal, 7-27
- counter signals
 - Counter *n* A, 7-27
 - Counter *n* Aux, 7-26
 - Counter *n* B, 7-27
 - Counter *n* Gate, 7-25
 - Counter *n* HW Arm, 7-27
 - Counter *n* Internal Output, 7-28
 - Counter *n* Source, 7-24
 - Counter *n* TC, 7-28
 - Counter *n* Up_Down, 7-27
 - FREQ OUT, 7-28
 - Frequency Output, 7-28
- counters, 7-1
 - cascading, 7-30
 - connecting terminals, 7-28
 - duplicate count prevention, 7-32
 - edge counting, 7-2
 - filters, 7-30
 - generation, 7-19
 - input applications, 7-1
 - other features, 7-30
 - output applications, 7-19
 - prescaling, 7-32
 - pulse train generation, 7-21
 - retriggerable single pulse generation, 7-20
 - simple pulse generation, 7-19
 - single pulse generation, 7-19
 - single pulse generation with start trigger, 7-20
 - synchronization modes, 7-35

- timing diagrams, B-31
 - counter input delays, B-31
- timing signals, 7-24
- triggering, 7-29
- troubleshooting, C-3
- counting edges, 7-2
- crossstalk when sampling multiple channels, C-1
- custom cabling, 2-7

D

- DACs, 5-1
- DAQ
 - hardware, 2-1
 - system, 2-1
- DAQ-6202, 2-2
- DAQ-STC2, 2-2
- data
 - acquisition methods, 4-9
 - generation methods, 5-3
 - transfer methods, 10-1, 10-2
 - DMA, 10-1
 - IRQ, 10-2
 - programmed I/O, 10-2, 10-3
 - USB Signal Stream, 10-2
- default
 - counter terminals, 7-28
 - NI-DAQmx counter/timer pins, 7-28
 - pins, 7-28
- detection, troubleshooting, C-3
- device
 - information, A-1
 - multiple synchronization, 9-3
 - NI 6220, A-2
 - NI 6221, A-4
 - NI 6224, A-13
 - NI 6225, A-15
 - NI 6229, A-21
 - NI 6250, A-27
 - NI 6251, A-29
 - NI 6254, A-37
 - NI 6255, A-39
 - NI 6259, A-45
 - NI 6280, A-53
 - NI 6281, A-55

- NI 6284, A-61
- NI 6289, A-63
- pinouts, 1-13
- self-calibration, 1-4
- specifications, A-1
- DI change detection, 6-7
- DI Sample Clock signal, 6-3
- di/SampleClock, 6-3
- DIFF connections
 - using with floating signal sources, 4-13
 - using with ground-referenced signal sources, 4-19
 - when to use with floating signal sources, 4-12
 - when to use with ground-referenced signal sources, 4-18
- differential analog input, troubleshooting, C-1
- differential connections
 - using with floating signal sources, 4-13
 - using with ground-referenced signal sources, 4-19
 - when to use with floating signal sources, 4-12
 - when to use with ground-referenced signal sources, 4-18
- digital
 - waveform acquisition, 6-3
 - waveform generation, 6-4
- digital I/O, 6-1
 - block diagram, 6-1
 - circuitry, 6-1
 - connecting signals, 6-8
 - DI change detection, 6-7
 - digital waveform generation, 6-4
 - getting started with applications in software, 6-9
 - I/O protection, 6-5
 - programmable power-up states, 6-6
 - static DIO, 6-2
 - timing diagrams, B-28
 - triggering, 11-1
 - waveform acquisition, 6-3
 - waveform triggering, 6-2
- digital routing, 9-1

digital signals

- Change Detection Event, 6-7
- connecting, 6-8
- DI Sample Clock, 6-3
- DO Sample Clock, 6-4

digital source, triggering, 11-1

digital waveform

- acquisition, 6-3
- generation, 6-4

disk drive power (PCI Express), 1-5

disk drive power connector (PCI Express devices), 1-5

DMA, 10-2

- as a transfer method, 10-1
- changing data transfer methods, 10-2, 10-3
- controllers, 10-2

DO Sample Clock signal, 6-4

do/SampleClock, 6-4

double-buffered acquisition, 4-9

duplicate count prevention, 7-32

- enabling in NI-DAQmx, 7-35
- example, 7-33
- prevention example, 7-34
- troubleshooting, C-3

E

E Series

- differences from M Series, D-4
- migrating applications from, D-4
- pinout comparison versus M Series, D-1
- upgrading from, D-4

edge counting, 7-2

- buffered, 7-3
- on-demand, 7-2
- sample clock, 7-3
- single point, 7-2

edge-separation measurement

- buffered two-signal, 7-18
- single two-signal, 7-18

enabling duplicate count prevention in

NI-DAQmx, 7-35

encoders, quadrature, 7-15

encoding

- X1, 7-15
- X2, 7-15
- X4, 7-15

equivalent time sampling, 7-23

example programs, E-1

exporting timing output signals using PFI terminals, 8-2

external reference clock, 9-2

external source mode, 7-36

F

features, counter, 7-30

field wiring considerations, 4-21

filters

- counter, 7-30
- PFI, 8-4
- PXI_STAR, 9-8
- RTSI, 9-6

finite pulse train timing generation, 7-22

floating signal sources

- connecting, 4-12
- description, 4-12
- using in differential mode, 4-13
- using in NRSE mode, 4-16
- using in RSE mode, 4-17
- when to use in differential mode, 4-12
- when to use in NRSE mode, 4-12
- when to use in RSE mode, 4-13

FREQ OUT signal, 7-28

frequency

- division, 7-23
- generation, 7-22
- generator, 7-22
- measurement, 7-8

Frequency Output signal, 7-28

fuse replacement

- USB-6221 Screw Terminal, A-8, A-10
- USB-6225 Mass Termination, A-20
- USB-6225 Screw Terminal, A-18
- USB-6229 BNC, A-26
- USB-6229 Screw Terminal, A-24, A-32
- USB-6251 BNC, A-34
- USB-6251 Mass Termination, A-36

USB-6251 Screw Terminal, A-32, A-42,
A-48, A-58, A-66

USB-6255 Mass Termination, A-44

USB-6255 Screw Terminal, A-42

USB-6259 BNC, A-50

USB-6259 Mass Termination, A-52

USB-6259 Screw Terminal, A-48

USB-6281 Mass Termination, A-60

USB-6281 Screw Terminal, A-58

USB-6289 Mass Termination, A-68

USB-6289 Screw Terminal, A-66

fuse replacement (USB devices), 3-7

G

generations

analog output data, 5-3

buffered hardware-timed, 5-4

clock, 9-1

continuous pulse train, 7-21

digital waveform, 6-4

frequency, 7-22

hardware-timed, 5-4

non-buffered hardware-timed, 5-5

pulse for ETS, 7-23

pulse train, 7-21

retriggerable single pulse, 7-20

simple pulse, 7-19

single pulse, 7-19

single pulse with start trigger, 7-20

software-timed, 5-3

getting started, 1-3

AI applications in software, 4-32

AO applications in software, 5-10

DIO applications in software, 6-9

ghost voltages when sampling multiple
channels, C-1

ground-reference

connections, checking, C-1

settings, 4-1, 4-4

analog input, 4-4

ground-referenced signal sources

connecting, 4-17

description, 4-17

using in differential mode, 4-19

using in NRSE mode, 4-20

when to use in differential mode, 4-18

when to use in NRSE mode, 4-18

when to use in RSE mode, 4-19

H

hardware, 2-1

hardware installation, 1-3

hardware-timed

acquisitions, 4-9

generations, 5-4

hysteresis, analog edge triggering with, 11-4

I

I/O connector, 3-1

PCI/PCIe/PXI/PXIe-6251 pinout, A-29

PCI/PCIe/PXI/PXIe-6259 pinout, A-45

PCI/PXI-6220 pinout, A-2

PCI/PXI-6221 (68-pin) pinout, A-4

PCI/PXI-6224 pinout, A-13

PCI/PXI-6225 pinout, A-15

PCI/PXI-6229 pinout, A-21

PCI/PXI-6250 pinout, A-27

PCI/PXI-6254 pinout, A-37

PCI/PXI-6255 pinout, A-39

PCI/PXI-6280 pinout, A-53

PCI/PXI-6281 pinout, A-55

PCI/PXI-6284 pinout, A-61

PCI/PXI-6289 pinout, A-63

PCI-6221 (37-pin) pinout, A-11

USB-6221 BNC pinout, A-9

USB-6221 Screw Terminal pinout, A-7

USB-6225 Mass Termination
pinout, A-19

USB-6225 Screw Terminal pinout, A-17

USB-6229 BNC pinout, A-25

USB-6229 Screw Terminal pinout, A-23

USB-6251 BNC pinout, A-33

USB-6251 Mass Termination
pinout, A-35

USB-6251 Screw Terminal pinout, A-31

USB-6255 Mass Termination
pinout, A-43

USB-6255 Screw Terminal pinout, A-41

USB-6259 BNC pinout, A-49

- USB-6259 Mass Termination pinout, A-51
- USB-6259 Screw Terminal pinout, A-47
- USB-6281 Mass Termination pinout, A-59
- USB-6281 Screw Terminal pinout, A-57
- USB-6289 Mass Termination pinout, A-67
- USB-6289 Screw Terminal pinout, A-65
- I/O protection, 6-5, 8-5
- improving analog trigger accuracy, 11-6
- input signals
 - using PFI terminals as, 8-2
 - using RTSI terminals as, 9-6
- input timing, analog input, B-3
- insertion of grounded channels between signal channels, 4-7
- installation
 - hardware, 1-3
 - NI-DAQ, 1-3
 - other software, 1-3
 - troubleshooting, C-3
- instrumentation amplifier, 4-1
- interface, bus, 10-1
- internal timing, analog input, B-5
- interrupt request, as a transfer method, 10-2
- IRQ
 - as a transfer method, 10-2
 - changing data transfer methods, 10-2, 10-3

L

- LabVIEW documentation, E-3
- LabVIEW Real-Time documentation, E-3
- LabWindows/CVI documentation, E-3
- LED patterns
 - USB devices, 3-7
 - USB-6221 Screw Terminal, A-8, A-10, A-14, A-16
 - USB-6225 Mass Termination, A-20
 - USB-6225 Screw Terminal, A-18
 - USB-6229 BNC, A-26
 - USB-6229 Screw Terminal, A-24
 - USB-6251 BNC, A-34
 - USB-6251 Mass Termination, A-36

- USB-6251 Screw Terminal, A-32
- USB-6255 Mass Termination, A-44
- USB-6255 Screw Terminal, A-42
- USB-6259 BNC, A-50
- USB-6259 Mass Termination, A-52
- USB-6259 Screw Terminal, A-48
- USB-6281 Mass Termination, A-60
- USB-6281 Screw Terminal, A-58
- USB-6289 Mass Termination, A-68
- USB-6289 Screw Terminal, A-66
- low impedance sources, 4-6
- lowpass filter, analog input, 4-3

M

M Series

- and E Series accessories, D-4
- differences from E Series, D-4
- information, A-1
- migrating applications to, D-4
- pinout comparison versus E Series, D-1
- specifications, A-1
- upgrading to, D-4
- Measurement Studio documentation, E-3
- measurements
 - buffered period, 7-6
 - buffered pulse-width, 7-4
 - buffered semi-period, 7-7
 - buffered two-signal
 - edge-separation, 7-18
 - choosing frequency, 7-11
 - frequency, 7-8
 - period, 7-5
 - position, 7-14
 - pulse-width, 7-3
 - semi-period, 7-7
 - single period, 7-5
 - single pulse-width, 7-4
 - single semi-period, 7-7
 - single two-signal edge-separation, 7-18
 - two-signal edge-separation, 7-17
 - using quadrature encoders, 7-15
 - using two pulse encoders, 7-16

- measuring
 - high frequency with two counters, 7-9
 - large range of frequencies using two counters, 7-10
 - low frequency with one counter, 7-8
 - averaged, 7-9
- methods, data transfer, 10-1, 10-2
- minimizing
 - glitches on the output signal, 5-3
 - output signal glitches, C-2
 - voltage step between adjacent channels, 4-8
- multichannel scanning considerations, 4-6
- multiple device synchronization, 9-3
- MUX, 4-1

N

- .NET languages documentation, E-4
- NI 6220, A-2
 - accessory options, A-3
 - cabling options, A-3
 - pinout, A-2
 - specifications, A-3
- NI 6221, A-4
- NI 6224, A-13
 - accessory options, A-14, A-20
 - cabling options, A-14, A-20
 - pinout, A-13
 - specifications, A-14, A-16
- NI 6225, A-15
 - specifications, A-20
- NI 6229, A-21
- NI 6250, A-27
 - accessory options, A-28
 - cabling options, A-28
 - pinout, A-27
 - specifications, A-28
- NI 6251, A-29
 - specifications, A-36
- NI 6254, A-37
 - accessory options, A-38
 - cabling options, A-38
 - pinout, A-37
 - specifications, A-38
- NI 6255, A-39
 - specifications, A-40, A-44
- NI 6259, A-45
 - specifications, A-52
- NI 6280, A-53
 - accessory options, A-54
 - cabling options, A-54
 - pinout, A-53
 - specifications, A-54
- NI 6281, A-55
 - specifications, A-56
- NI 6284, A-61
 - accessory options, A-62
 - cabling options, A-62
 - pinout, A-61
 - specifications, A-62
- NI 6289, A-63
 - specifications, A-64, A-68
- NI-DAQmx
 - default counter terminals, 7-28
 - documentation, E-1
 - enabling duplicate count prevention, 7-35
 - installation, 1-3
- NI-PGIA, 4-1
- non-buffered
 - hardware-timed acquisitions, 4-10
 - hardware-timed generations, 5-5
- non-referenced single-ended connections
 - using with floating signal sources, 4-16
 - using with ground-referenced signal sources, 4-20
 - when to use with floating signal sources, 4-12
 - when to use with ground-referenced signal sources, 4-18
- NRSE connections
 - using with floating signal sources, 4-16
 - using with ground-referenced signal sources, 4-20
 - when to use with floating signal sources, 4-12
 - when to use with ground-referenced signal sources, 4-18

O

- on-demand
 - acquisitions, 4-9
 - edge counting, 7-2
 - timing, 4-9
- options, 2-10
- order of channels for scanning, 4-7
- other
 - internal source mode, 7-36
 - software, installing, 1-3
- output
 - signal glitches, C-2
 - minimizing, 5-3
 - terminal, routing analog comparison
 - events, 11-3
- outputs, using RTSI as, 9-5
- overview, 2-1

P

- pause trigger, 7-30
 - analog input internal timing
 - diagram, B-17
- PCI Express
 - See also* PCIe-6251
 - See also* PCIe-6259
 - disk drive power connector, 1-5
- PCI/PCIe/PXI/PXIe-6251
 - accessory options, A-30
 - cabling options, A-30
 - pinout, A-29
 - specifications, A-30
- PCI/PCIe/PXI/PXIe-6259
 - accessory options, A-46
 - cabling options, A-46
 - pinout, A-45
 - specifications, A-46
- PCI/PXI-6221 (68-pin)
 - accessory options, A-6, A-12
 - cabling options, A-6, A-12
 - pinout, A-4
 - specifications, A-6
- PCI/PXI-6225
 - accessory options, A-16
 - cabling options, A-16
 - pinout, A-15
 - specifications, A-16
- PCI/PXI-6229
 - accessory options, A-22
 - cabling options, A-22
 - pinout, A-21
 - specifications, A-22
- PCI/PXI-6255
 - accessory options, A-40
 - cabling options, A-40
 - pinout, A-39
- PCI/PXI-6281
 - accessory options, A-56
 - cabling options, A-56
 - pinout, A-55
- PCI/PXI-6289, A-63
 - accessory options, A-64
 - cabling options, A-64
 - pinout, A-63
- PCI-6220, A-2
- PCI-6221 (37-pin)
 - pinout, A-11
 - specifications, A-12
- PCI-6221 (68-pin), A-4
- PCI-6224, A-13
- PCI-6225, A-15
- PCI-6229, A-21
- PCI-6250, A-27
- PCI-6251, A-29
- PCI-6254, A-37
- PCI-6255, A-39
- PCI-6259, A-45
- PCI-6280, A-53
- PCI-6281, A-55
- PCI-6284, A-61
- PCIe-6251, A-29
- PCIe-6259, A-45
- period measurement, 7-5
 - buffered, 7-6
 - single, 7-5

- PFI, 8-1
 - connecting input signals, 8-3
 - exporting timing output signals using
 - PFI terminals, 8-2
 - filters, 8-4
 - I/O protection, 8-5
 - programmable power-up states, 8-5
 - using terminals as static digital I/Os, 8-3
 - using terminals as timing input signals, 8-2
- PFI terminals as static digital I/Os, 8-3
- pin assignments. *See* pinouts
- pinouts
 - comparison, D-1
 - counter default, 7-28
 - device, 1-13
 - NI 6250, A-27
 - NI 6254, A-37
 - NI 6280, A-53
 - NI 6284, A-61
 - PCI/PCIe/PXI/PXIe-6251, A-29
 - PCI/PCIe/PXI/PXIe-6259, A-45
 - PCI/PXI-6220, A-2
 - PCI/PXI-6221 (68-pin), A-4
 - PCI/PXI-6224, A-13
 - PCI/PXI-6225, A-15
 - PCI/PXI-6229, A-21
 - PCI/PXI-6255, A-39
 - PCI/PXI-6281, A-55
 - PCI/PXI-6289, A-63
 - PCI-6221 (37-pin), A-11
 - RTSI connector, 3-7, 9-4
 - USB-6221 BNC, A-9
 - USB-6221 Screw Terminal, A-7
 - USB-6225 Mass Termination, A-19
 - USB-6225 Screw Terminal, A-17
 - USB-6229 BNC, A-25
 - USB-6229 Screw Terminal, A-23
 - USB-6251 BNC, A-33
 - USB-6251 Mass Termination, A-35
 - USB-6251 Screw Terminal, A-31
 - USB-6255 Mass Termination, A-43
 - USB-6255 Screw Terminal, A-41
 - USB-6259 BNC, A-49
 - USB-6259 Mass Termination, A-51
 - USB-6259 Screw Terminal, A-47
 - USB-6281 Mass Termination, A-59
 - USB-6281 Screw Terminal, A-57
 - USB-6289 Mass Termination, A-67
 - USB-6289 Screw Terminal, A-65
- pins, default, 7-28
- position measurement, 7-14
 - buffered, 7-17
- power
 - +5 V, 3-5
 - connector, PCI Express disk drive, 1-5
 - rail, D-4
- power-up states, 6-6, 8-5
- prescaling, 7-32
- programmable
 - function interface (PFI), 8-1
 - power-up states, 6-6, 8-5
- programmed I/O, 10-2, 10-3
 - changing data transfer methods, 10-3
- programming devices in software, 2-11
- pulse
 - encoders, 7-16
 - generation for ETS, 7-23
 - train generation, 7-21
 - continuous, 7-21
- pulse-width measurement, 7-3
 - buffered, 7-4
 - single, 7-4
- PXI
 - and PXI Express, 10-3
 - clock, 10-3
 - clock and trigger signals, 9-8
 - considerations, 10-3
 - trigger signals, 10-3
 - triggers, 9-8
 - using with CompactPCI, 10-4
- PXI Express
 - See also* PXIe-6251
 - See also* PXIe-6259
 - and PXI, 10-3
 - chassis compatibility, 10-3
- PXI_CLK10, 9-8
- PXI_STAR
 - filters, 9-8
 - trigger, 9-8

- PXI-6220, A-2
- PXI-6221, A-4
- PXI-6224, A-13
- PXI-6225, A-15
- PXI-6229, A-21
- PXI-6250, A-27
- PXI-6251, A-29
- PXI-6254, A-37
- PXI-6255, A-39
- PXI-6259, A-45
- PXI-6280, A-53
- PXI-6281, A-55
- PXI-6284, A-61
- PXIe-6251, A-29
- PXIe-6259, A-45

Q

- quadrature encoders, 7-15

R

- range, analog input, 4-2
- real-time system integration bus, 9-4
- reciprocal frequency measurement, 7-10
- reference
 - clock
 - 10 MHz, 9-2
 - external, 9-2
 - trigger, analog input internal timing, B-13
- referenced single-ended connections
 - using with floating signal sources, 4-17
 - when to use with floating signal sources, 4-13
 - when to use with ground-referenced signal sources, 4-19
- retriggerable single pulse generation, 7-20
- routing
 - analog comparison event to an output terminal, 11-3
 - clock, 9-1
 - digital, 9-1
- RSE configuration, 4-17

- RSE connections
 - using with floating signal sources, 4-17
 - when to use with floating signal sources, 4-13
 - when to use with ground-referenced signal sources, 4-19

- RTSI, 9-4
 - connector pinout, 3-7, 9-4
 - filters, 9-6
 - using as outputs, 9-5
 - using terminals as timing input signals, 9-6

S

- safety guidelines
 - for hazardous voltages, 1-2
- sample clock
 - analog input internal timing, B-15
 - edge counting, 7-3
- sample clock measurement, 7-17
- scanning speed, 4-8
- SCC, 2-11
- SCXI, 2-10
 - self-calibration, 1-4
- semi-period measurement, 7-7
 - buffered, 7-7
 - single, 7-7
- sensors, 2-10
- settings
 - analog input ground-reference, 4-4
 - AO offset, 5-2
 - AO reference selection, 5-2
- short high-quality cabling, 4-7
- signal conditioning, 2-10
 - options, 2-10
- signal descriptions, 3-1
- signal label
 - USB screw terminal devices, 1-6
- signal routing, RTSI bus, 9-4
- signal sources
 - floating, 4-12
 - ground-referenced, 4-17
- Signal Stream, USB, 10-2

signals

- AI Convert Clock, 4-25
- AI Convert Clock Timebase, 4-29
- AI Hold Complete Event, 4-29
- AI Pause Trigger, 4-31
- AI Reference Trigger, 4-30
- AI Sample Clock, 4-23
- AI Sample Clock Timebase, 4-25
- AI Start Trigger, 4-29
- analog input, 4-21
- analog output, 5-6
- AO Pause Trigger, 5-7
- AO Sample Clock, 5-8
- AO Sample Clock Timebase, 5-9
- AO Start Trigger, 5-6
- Change Detection Event, 6-7
- connecting analog input, 4-11
- connecting analog output, 5-5
- connecting counter, C-3
- connecting digital I/O, 6-8
- connecting PFI input, 8-3
- Counter *n* A, 7-27
- Counter *n* Aux, 7-26
- Counter *n* B, 7-27
- Counter *n* Gate, 7-25
- Counter *n* HW Arm, 7-27
- Counter *n* Internal Output, 7-28
- Counter *n* Source, 7-24
- Counter *n* TC, 7-28
- Counter *n* Up_Down, 7-27
- Counter *n* Z, 7-27
- counters, 7-24
- DI Sample Clock, 6-3
- DO Sample Clock, 6-4
- exporting timing output using PFI terminals, 8-2
- FREQ OUT, 7-28
- Frequency Output, 7-28
- minimizing output glitches, C-2
- output, minimizing glitches on, 5-3
- simple pulse generation, 7-19
- single
 - period measurement, 7-5
 - point edge counting, 7-2
 - pulse generation, 7-19
 - retriggerable, 7-20
 - with start trigger, 7-20
 - pulse-width measurement, 7-4
 - semi-period measurement, 7-7
 - two-signal edge-separation measurement, 7-18
- single-ended connections
 - for floating signal sources, 4-17
 - RSE configuration, 4-17
- software, 1-3
 - configuring AI ground-reference settings, 4-6
 - programming devices, 2-11
- software-timed
 - acquisitions, 4-9
 - generations, 5-3
- specifications, A-1
 - PCI/PCIe/PXI/PXIe-6251, A-30
 - PCI/PCIe/PXI/PXIe-6259, A-46
 - PCI/PXI-6220, A-3
 - PCI/PXI-6221, A-6
 - PCI/PXI-6224, A-14, A-16
 - PCI/PXI-6225, A-16
 - PCI/PXI-6229, A-22
 - PCI/PXI-6250, A-28
 - PCI/PXI-6254, A-38
 - PCI/PXI-6255, A-40
 - PCI/PXI-6280, A-54
 - PCI/PXI-6281, A-56
 - PCI/PXI-6284, A-62
 - PCI/PXI-6289, A-64
 - PCI-6221 (37-pin), A-12
 - USB-6221 Screw Terminal, A-8, A-10, A-12, A-14, A-16
 - USB-6225 Mass Termination, A-20
 - USB-6225 Screw Terminal, A-18
 - USB-6229 BNC, A-26
 - USB-6229 Screw Terminal, A-24, A-32
 - USB-6251 BNC, A-34
 - USB-6251 Mass Termination, A-36
 - USB-6251 Screw Terminal, A-32
 - USB-6255 Mass Termination, A-44
 - USB-6255 Screw Terminal, A-42
 - USB-6259 BNC, A-50
 - USB-6259 Mass Termination, A-52

- USB-6259 Screw Terminal, A-48
 - USB-6281 Mass Termination, A-60
 - USB-6281 Screw Terminal, A-58
 - USB-6289 Mass Termination, A-68
 - USB-6289 Screw Terminal, A-66
 - start
 - analog input internal timing, B-9
 - trigger, 7-30
 - static DIO, 6-2
 - using PFI terminals as, 8-3
 - switching from a large to a small input range, 4-7
 - synchronization modes, 7-35
 - 80 MHz source, 7-36
 - external source, 7-36
 - other internal source, 7-36
 - synchronizing multiple devices, 9-3
 - synchronous counting mode, 7-32
- T**
- technical support, E-5
 - terminal configuration, 4-4
 - analog input, 4-1
 - terminal name, D-1
 - terminals
 - connecting counter, 7-28
 - NI-DAQmx default counter, 7-28
 - Timebase
 - 100 kHz, 9-2
 - 20 MHz, 9-2
 - 80 MHz, 9-2
 - timed acquisitions, 4-9
 - timing diagrams
 - AI timing clocks, B-5
 - analog input, B-1
 - analog input internal timing, B-5
 - analog input output timing, B-18
 - analog input pause trigger, B-17
 - analog input reference trigger, B-13
 - analog input sample clock, B-15
 - analog input signal definitions, B-2
 - analog input Start, B-9
 - analog input timing, B-3
 - analog output, B-20
 - analog output input timing, B-21
 - analog output Pause Trigger, B-26
 - analog output pause trigger, B-23
 - analog output signal definitions, B-20
 - analog output Start trigger, B-23
 - analog output timing Start trigger, B-25
 - clock generation, B-41
 - Convert Clock, B-7
 - count enable delays, B-34
 - counter gating modes, B-39
 - counter input requirements, B-35
 - counter output delays, B-38
 - counter pin to internal signal delays, B-32
 - counters, B-31
 - digital I/O, B-28
 - digital waveform acquisition, B-28
 - digital waveform generation, B-30
 - gate pulse width input requirements, B-36
 - gate to source setup and hold, B-36
 - input timing verification, B-24
 - internal analog output timing, B-22
 - output timing, B-25
 - pulse width input requirements, B-35
 - quadrature encoder, B-40
 - selected gate to count enable delays, B-34
 - selected gate to selected source delays, B-33
 - source period input requirements, B-35
 - two pulse encoder, B-40
 - timing output signals, exporting using PFI terminals, 8-2
 - training, E-5
 - transducers, 2-10
 - trigger, 11-1
 - analog actions, 11-3
 - arm start, 7-29
 - pause, 7-30
 - PXI, 9-8
 - PXI_STAR, 9-8
 - Star Trigger, 9-8
 - start, 7-30

- triggering, 11-1
 - analog accuracy, 11-6
 - analog actions, 11-3
 - analog edge, 11-3
 - analog edge with hysteresis, 11-4
 - analog input, 4-10
 - analog input channels, 11-2
 - analog types, 11-3
 - analog window, 11-5
 - APFI terminals, 11-2
 - counter, 7-29
 - digital waveform, 6-2
 - with a digital source, 11-1
 - with an analog source, 11-2
- troubleshooting
 - analog input, C-1
 - analog output, C-2
 - counters, C-3
 - installation, C-3
- two-signal edge-separation
 - measurement, 7-17
 - buffered, 7-18
 - single, 7-18
- types of analog triggers, 11-3

U

- upgrading from E Series to M Series, D-4
- USB
 - bulk transfers, 10-2
 - cable strain relief, 1-8, 1-12
 - Signal Stream, 10-2
- USB M Series
 - device security, 1-8
 - security cable slot, 1-8
- USB Signal Stream, 10-2
 - as a transfer method, 10-2
 - changing data transfer methods, 10-3
- USB-6221 BNC
 - cable management, 1-8
 - pinout, A-9
 - USB cable strain relief, 1-8
- USB-6221 Mass Termination
 - USB cable strain relief, 1-8
- USB-6221 Screw Terminal
 - accessory options, A-8, A-10, A-18, A-24, A-26, A-34, A-50
 - cabling options, A-8, A-10, A-18, A-24, A-26, A-34, A-50
 - fuse replacement, A-8, A-10
 - LED patterns, A-8, A-10, A-14, A-16
 - pinout, A-7
 - signal label, 1-6
 - specifications, A-8, A-10, A-12, A-14, A-16
 - USB cable strain relief, 1-8, 1-12
- USB-6225 Mass Termination, A-15
 - accessory options, A-20
 - cabling options, A-20
 - fuse replacement, A-20
 - LED patterns, A-20
 - pinout, A-19
 - specifications, A-20
 - USB cable strain relief, 1-8, 1-12
- USB-6225 Screw Terminal, A-15
 - fuse replacement, A-18
 - LED patterns, A-18
 - pinout, A-17
 - signal label, 1-6
 - specifications, A-18
 - USB cable strain relief, 1-8, 1-12
- USB-6229 BNC
 - cable management, 1-8
 - fuse replacement, A-26
 - LED patterns, A-26
 - pinout, A-25
 - specifications, A-26
 - USB cable strain relief, 1-8
- USB-6229 Screw Terminal
 - fuse replacement, A-24, A-32
 - LED patterns, A-24
 - pinout, A-23
 - signal label, 1-6
 - specifications, A-24, A-32
 - USB cable strain relief, 1-8, 1-12
- USB-6251 BNC
 - cable management, 1-8
 - fuse replacement, A-34
 - LED patterns, A-34

- pinout, A-33
- specifications, A-34
- USB cable strain relief, 1-8
- USB-6251 Mass Termination
 - accessory options, A-36
 - cabling options, A-36
 - fuse replacement, A-36
 - LED patterns, A-36
 - pinout, A-35
 - specifications, A-36
 - USB cable strain relief, 1-8, 1-12
- USB-6251 Screw Terminal
 - fuse replacement, A-32, A-42, A-48, A-58, A-66
 - LED patterns, A-32
 - pinout, A-31
 - signal label, 1-6
 - specifications, A-32
 - USB cable strain relief, 1-8, 1-12
- USB-6255
 - USB cable strain relief, 1-8, 1-12
- USB-6255 Mass Termination, A-39
 - accessory options, A-44
 - cabling options, A-44
 - fuse replacement, A-44
 - LED patterns, A-44
 - pinout, A-43
 - specifications, A-44
 - USB cable strain relief, 1-8, 1-12
- USB-6255 Screw Terminal, A-39
 - fuse replacement, A-42
 - LED patterns, A-42
 - pinout, A-41
 - signal label, 1-6
 - specifications, A-42
- USB-6259 BNC
 - cable management, 1-8
 - fuse replacement, A-50
 - LED patterns, A-50
 - pinout, A-49
 - specifications, A-50
 - USB cable strain relief, 1-8
- USB-6259 Mass Termination
 - accessory options, A-52
 - cabling options, A-52
 - fuse replacement, A-52
 - LED patterns, A-52
 - pinout, A-51
 - specifications, A-52
 - USB cable strain relief, 1-8, 1-12
- USB-6259 Screw Terminal
 - fuse replacement, A-48
 - LED patterns, A-48
 - pinout, A-47
 - signal label, 1-6
 - specifications, A-48
 - USB cable strain relief, 1-8, 1-12
- USB-6281 Mass Termination
 - accessory options, A-60
 - cabling options, A-60
 - fuse replacement, A-60
 - LED patterns, A-60
 - pinout, A-59
 - specifications, A-60
 - USB cable strain relief, 1-8, 1-12
- USB-6281 Screw Terminal
 - fuse replacement, A-58
 - LED patterns, A-58
 - pinout, A-57
 - signal label, 1-6
 - specifications, A-58
 - USB cable strain relief, 1-8, 1-12
- USB-6289 Mass Termination
 - accessory options, A-68
 - cabling options, A-68
 - fuse replacement, A-68
 - LED patterns, A-68
 - pinout, A-67
 - specifications, A-68
 - USB cable strain relief, 1-8, 1-12
- USB-6289 Screw Terminal
 - fuse replacement, A-66
 - LED patterns, A-66
 - pinout, A-65
 - signal label, 1-6
 - specifications, A-66
 - USB cable strain relief, 1-8, 1-12

using

- low impedance sources, 4-6

PFI terminals

- as static digital I/Os, 8-3
- as timing input signals, 8-2
- to export timing output signals, 8-2

RTSI

- as outputs, 9-5
- terminals as timing input signals, 9-6
- short high-quality cabling, 4-7
- the disk drive power connector (PCI Express), 1-5

W

waveform

- generation
 - digital, 6-4
 - signals, 5-6
- triggering, 6-2

X

- X1 encoding, 7-15
- X2 encoding, 7-15
- X4 encoding, 7-15