

## COMPREHENSIVE SERVICES

We offer competitive repair and calibration services, as well as easily accessible documentation and free downloadable resources.

## SELL YOUR SURPLUS

We buy new, used, decommissioned, and surplus parts from every NI series. We work out the best solution to suit your individual needs.

 Sell For Cash    Get Credit    Receive a Trade-In Deal

## OBSOLETE NI HARDWARE IN STOCK & READY TO SHIP

We stock **New**, **New Surplus**, **Refurbished**, and **Reconditioned** NI Hardware.



*Bridging the gap between the manufacturer and your legacy test system.*

 1-800-915-6216

 [www.apexwaves.com](http://www.apexwaves.com)

 [sales@apexwaves.com](mailto:sales@apexwaves.com)

*All trademarks, brands, and brand names are the property of their respective owners.*

**Request a Quote**

 **CLICK HERE**

**CB-68T**

# CB-27T, TBX-68T, AND CB-68T ISOTHERMAL TERMINAL BLOCKS INSTALLATION GUIDE

This installation guide describes how to install and connect signals to the CB-27T, TBX-68T, and CB-68T isothermal terminal blocks for use with the NI 435X products, which includes the NI USB-4350 for computers that are USB compatible, NI PCMCIA-4350 for computers that are PCMCIA compatible, NI PXI-4351 for PXI and CompactPCI chassis, and NI PCI-4351 for PCI bus computers.

The CB-27T isothermal terminal block is a shielded board with screw terminals that connects to the NI PCMCIA-4350 input/output (I/O) connector.

The TBX-68T isothermal terminal block is a DIN rail-mountable terminal block that consists of a shielded board with screw terminals and digital signal conditioning accessory connections. It connects to the I/O connector on the NI USB-4350, NI PXI-4351, and NI PCI-4351.

The CB-68T isothermal terminal block is a CA-1000 enclosure-mountable terminal block that consists of a shielded board with screw terminals and digital signal conditioning accessory connections. It connects to the I/O connector on the NI USB-4350, NI PXI-4351, and NI PCI-4351.

The terminal blocks can easily accommodate thermocouples, resistance temperature detectors (RTDs), thermistors, and voltage signals. The terminal blocks feature isothermal construction to minimize the temperature gradients across the screw terminals and a high-accuracy thermistor cold-junction temperature sensor for measuring with thermocouples. Enclosures keep out air currents to maintain an isothermal environment for the screw terminals and the cold-junction sensor. The TBX-68T mounts on most European standard DIN EN mounting rails. The TBX-68T and CB-68T also have connectors for cables from selected relay and digital signal conditioning modules.

The terminal blocks provide connections to all digital I/O (DIO) lines on the NI 435X devices. The terminal blocks also provide connections to all except two analog input channels (CH)—CH0 is dedicated for the

---

National Instruments™, NI™, ni.com™, and NI-DAQ™ are trademarks of National Instruments Corporation. Product and company names mentioned herein are trademarks or trade names of their respective companies. For patents covering National Instruments products, refer to the appropriate location: **Help»Patents** in your software, the `patents.txt` file on your CD, or [ni.com/patents](http://ni.com/patents).

October 2002  
321613D-01

cold-junction sensor and CH1 is dedicated for auto-zeroing circuitry. Refer to the *NI 435X User Manual* for further details on these two channels.

## Conventions

---

The following conventions are used in this guide:

» The » symbol leads you through nested menu items and dialog box options to a final action. The sequence **File»Page Setup»Options** directs you to pull down the **File** menu, select the **Page Setup** item, and select **Options** from the last dialog box.

◆ The ◆ symbol indicates that the following text applies only to a specific product, a specific operating system, or a specific software version.



This icon denotes a note, which alerts you to important information.



This icon denotes a caution, which advises you of precautions to take to avoid injury, data loss, or a system crash. When this symbol is marked on the product, see the *Read Me First: Safety and Radio-Frequency Interference* document, shipped with the product, for precautions to take.

**bold** Bold text denotes items that you must select or click in the software, such as menu items and dialog box options. Bold text also denotes parameter names.

monospace Text in this font denotes text or characters that you should enter from the keyboard, sections of code, programming examples, and syntax examples. This font is also used for the proper names of disk drives, paths, directories, programs, subprograms, subroutines, device names, functions, operations, variables, filenames and extensions, and code excerpts.

*italic* Italic text denotes variables, emphasis, a cross reference, or an introduction to a key concept. This font also denotes text that is a placeholder for a word or value that you must supply.

## What You Need to Get Started

---

You need the following to set up and use the accessories:

- One of the following NI 435X devices:
  - NI PCMCIA-4350 or NI USB-4350
  - NI PXI-4351 or NI PCI-4351
- NI 435X User Manual*

- CB-27T, TBX-68T, and CB-68T Isothermal Terminal Blocks Installation Guide*
- Read Me First: Safety and Radio-Frequency Interference*
- One of the following isothermal terminal blocks:
  - NI PCMCIA-4350
    - CB-27T isothermal terminal block
  - NI USB-4350, NI PXI-4351, and NI PCI-4351
    - TBX-68T isothermal terminal block
    - CB-68T isothermal terminal block
- One of the following cable assemblies:
  - NI PCMCIA-4350
    - PSH32-30F shielded cable
  - NI USB-4350, NI PXI-4351, and NI PCI-4351
    - SH6868 shielded cable (recommended)
    - R6868 ribbon cable
- Tie wraps (for CB-27T installation only)
- 1/8 in. flathead screwdriver
- Number 1 Phillips screwdriver
- Wire cutters
- Wire insulation strippers

For the CB-68T only:

- CA-1000 accessory enclosure
- CA-1000 Configurable Connector Accessory Enclosure Installation Guide*

For digital signal conditioning only:

- Digital signal conditioning accessory and its documentation
- NB7 or NB8 cable as required

# Installing the CB-68T into the CA-1000 Enclosure

---



**Caution** Refer to the *Read Me First: Safety and Radio-Frequency Interference* document before removing equipment covers or connecting/disconnecting any signal wires.

Refer to Figure 1 as you complete the following steps to install the CB-68T into the CA-1000 enclosure:

1. Remove the top cover of the CA-1000 by unscrewing the eight screws with a Phillips screwdriver.
2. Remove the rear panel of the CA-1000 enclosure by unscrewing the four screws at the top of the panel using a Phillips screwdriver.
3. Remove one of the half-panelettes (either the left or the right) by removing the screw at the top of the panelette. If installing two CB-68T units, remove both half-panelettes.

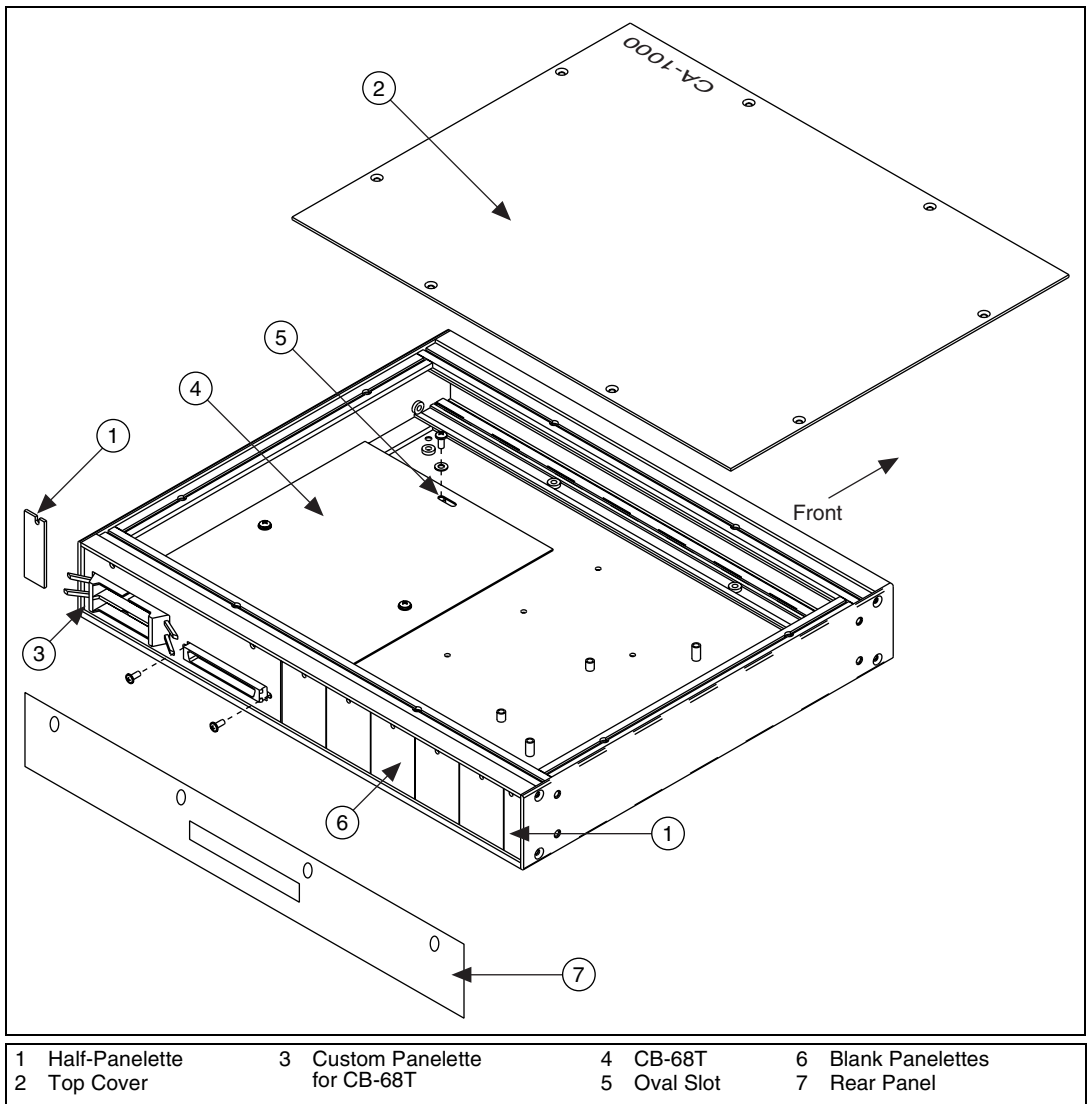


**Note** The CA-1000 holds up to two CB-68T units or one CB-68T unit and one digital signal conditioning accessory.

4. Install the custom panelette provided with the CB-68T on the side that the half panelette was removed from in step 3.
5. Insert the CB-68T in the CA-1000 enclosure so that the 68-pin connector comes through the opening in the custom panelette. Attach the CB-68T with the screws provided.
6. Place the washer on the screw and screw it into the oval slot in the CB-68T board.
7. Install up to five blank panelettes in the rear of the CA-1000 enclosure to fill openings. Tighten the screws with a Phillips screwdriver.
8. Install the desired connector panelettes in the front of the CA-1000 enclosure. Many connector panelettes are available including thermocouple connectors, BNC connectors, and banana jacks. Refer to the *CA-1000 Configurable Connector Accessory Enclosure Installation Guide* for more information.
9. Connect the signal wires as directed in the [Connecting the Signals to the TBX-68T, CB27T, and CB-68T](#) section of this document.
10. Replace the top cover.



**Note** To enable direct cabling on the CB-68T to an accessory in the same CA-1000 enclosure, you can optionally install two standard vertical 50-pin connectors on the CB-68T in the locations provided. Do not connect an accessory to the external accessory connector if you are using the internal accessory connector.



**Figure 1.** Installing the CB-68T

# Connecting the Signals to the TBX-68T, CB27T, and CB-68T

---



**Caution** Refer to the *Read Me First: Safety and Radio-Frequency Interference* document before removing equipment covers or connecting/disconnecting any signal wires.

Refer to Figures 2, 3, and 4 as you complete the following steps to connect the signals to the terminal block:

1. Remove the CB-27T or TBX-68T terminal block cover by unscrewing the four cover screws using the Phillips screwdriver.
2. Remove the front panel of the CB-27T.
3. Use wire cutters and wire insulation strippers to strip 6 mm (.25 in.) from the end of the signal wires to connect them to the screw terminals.
4. Loosen the screws in the screw terminals with a 1/8 in. flathead screwdriver.
5. Insert the stripped wires into the screw terminals. Tighten the screw terminals with the 1/8 in. flathead screwdriver.



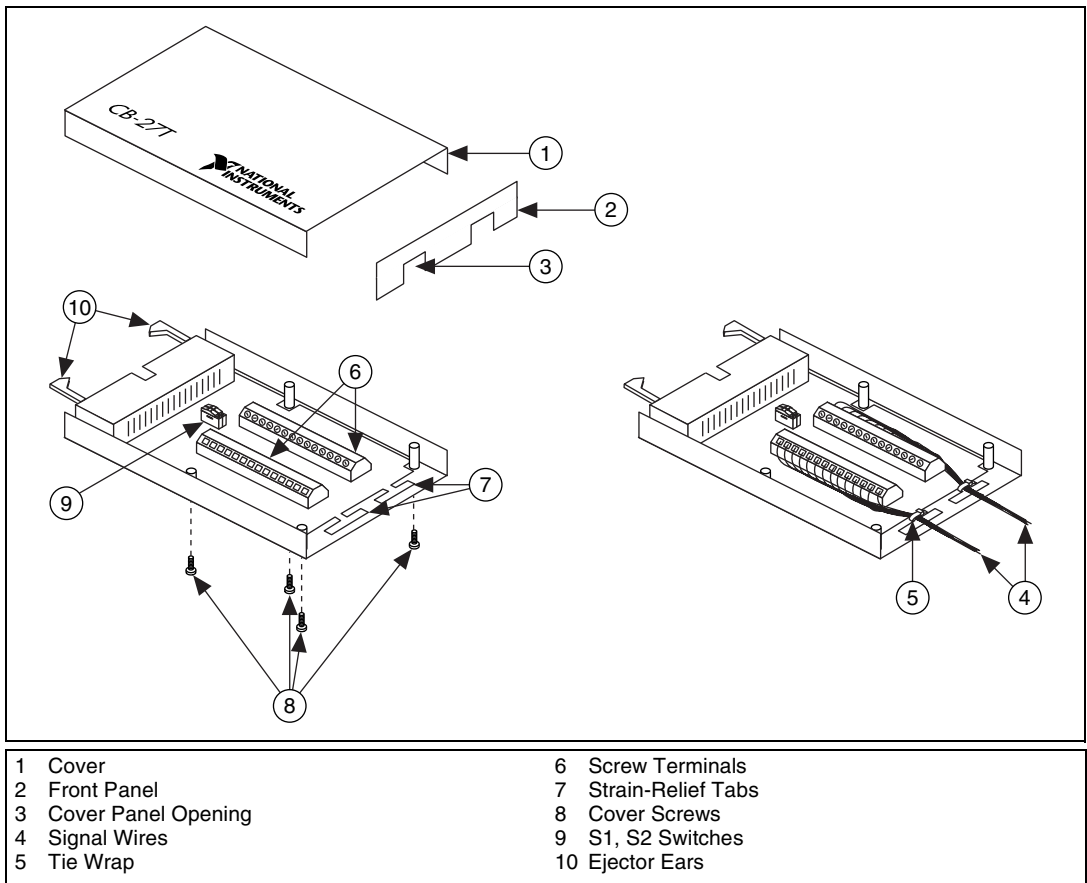
**Note** If you use digital signal conditioning accessories on the TBX-68T or CB-68T, lock the cable connectors in place with the ejector ears.

6. Make sure the signal wires can exit through the CB-27T or TBX-68T terminal block cover panel opening. On the CB-27T, you can use tie wraps to tie the wires to the strain-relief tabs. On the CB-68T, you can use a strain-relief panelette or wire the signals to a variety of available connector panelettes. Many connector panelettes are available including thermocouple connectors, BNC connectors, and banana jacks. Refer to the *CA-1000 Configurable Connector Accessory Enclosure Installation Guide* for more information.



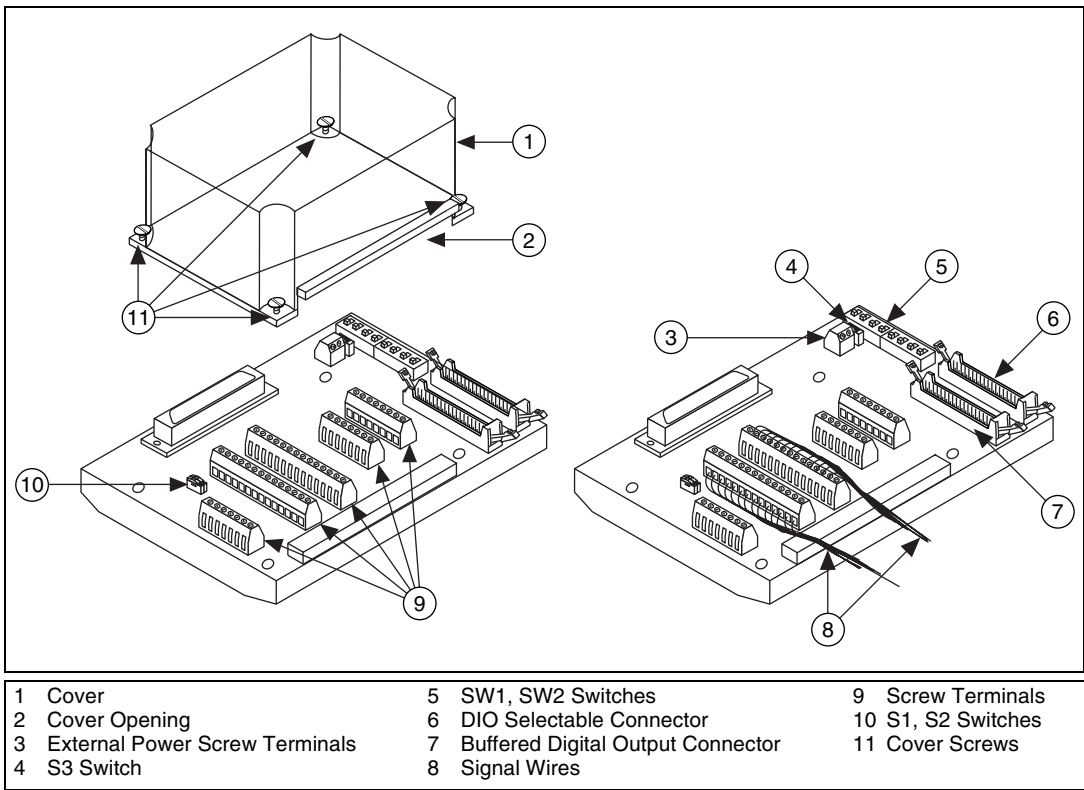
**Note** The TBX-68T and CB-68T terminal blocks do not provide strain relief for signal wires. Add strain relief and insulation for the signal wires, if necessary.

7. Replace the front panel of the CB-27T.
8. Replace the terminal block cover and tighten the cover screws.

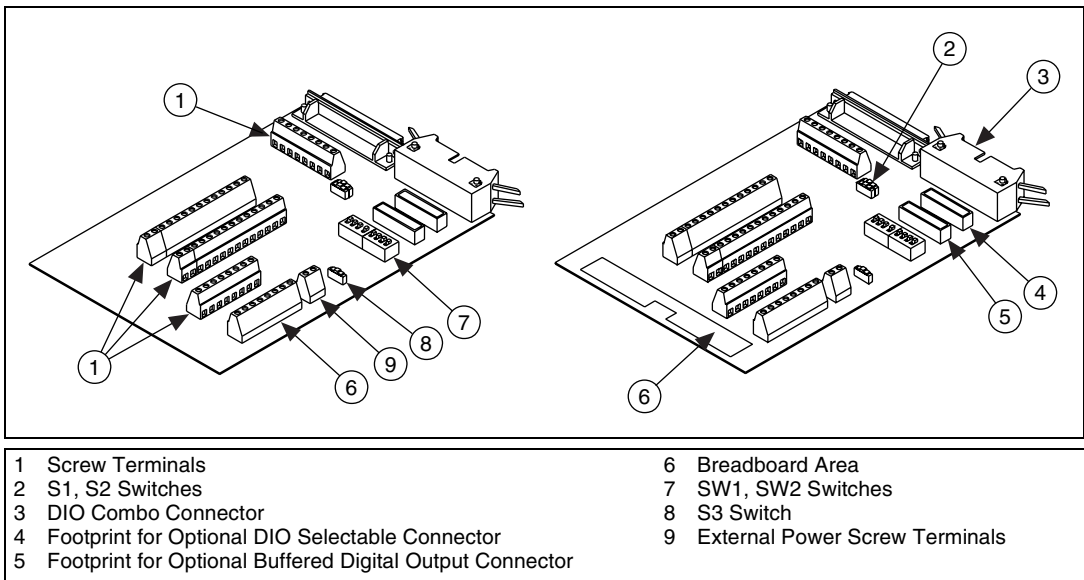


**Figure 2.** CB-27T Parts Locator Diagram





**Figure 3.** TBX-68T Parts Locator Diagram



**Figure 4.** CB-68T Parts Locator Diagram

# Connecting the TBX-68T, CB-27T, and CB-68T to the NI 435X

---



**Note** To minimize the temperature gradient inside the terminal block and thus maintain its isothermal nature for accurate cold-junction compensation, place the terminal block away from extreme temperature differentials.

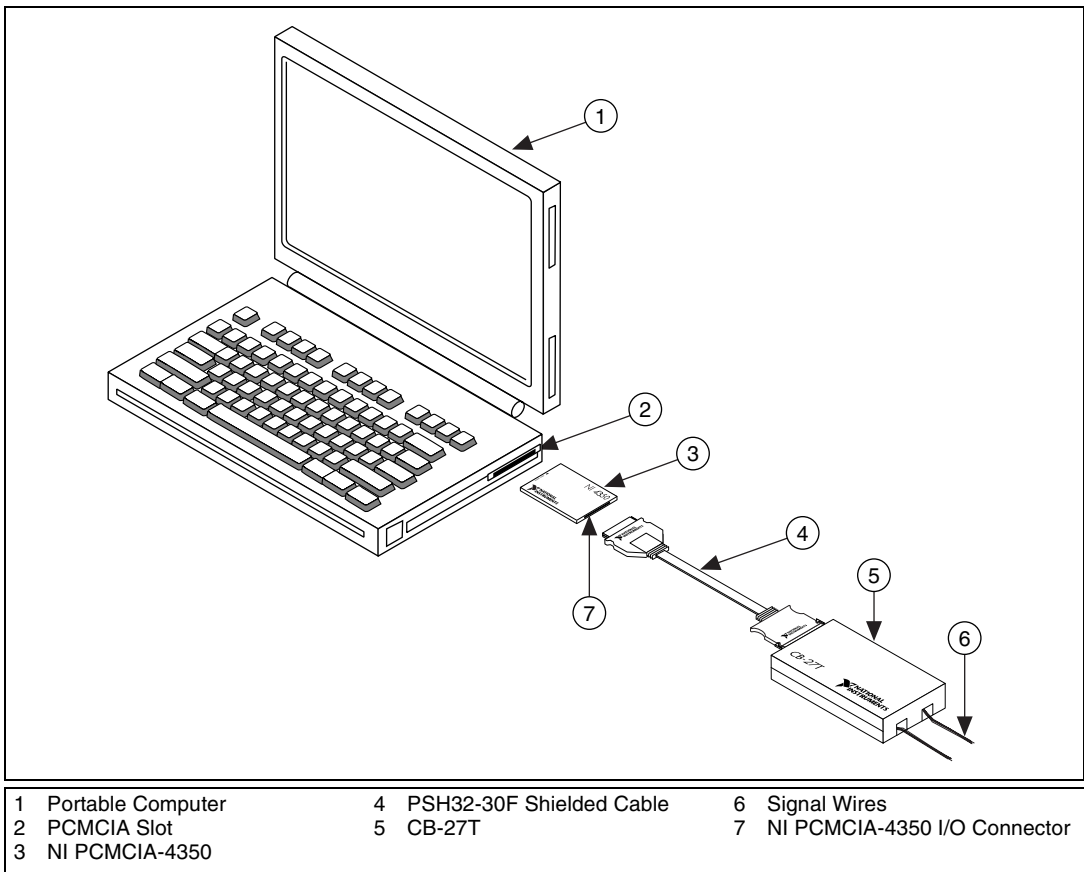
Refer to Figures 5, 6, and 7 as you complete the following steps to connect the terminal block to the NI 435X connector:

1. Attach one end of the cable to the NI 435X device.
  2. Attach the other end of the cable to the terminal block.
- ◆ On the CB-27T, use the ejector ears to lock the cable connector in place.
  - ◆ On the TBX-68T and CB-68T, if you use the SH6868 cable, the two connectors snap together. The R6868 ribbon cable has no latches and simply joins together without a snap.

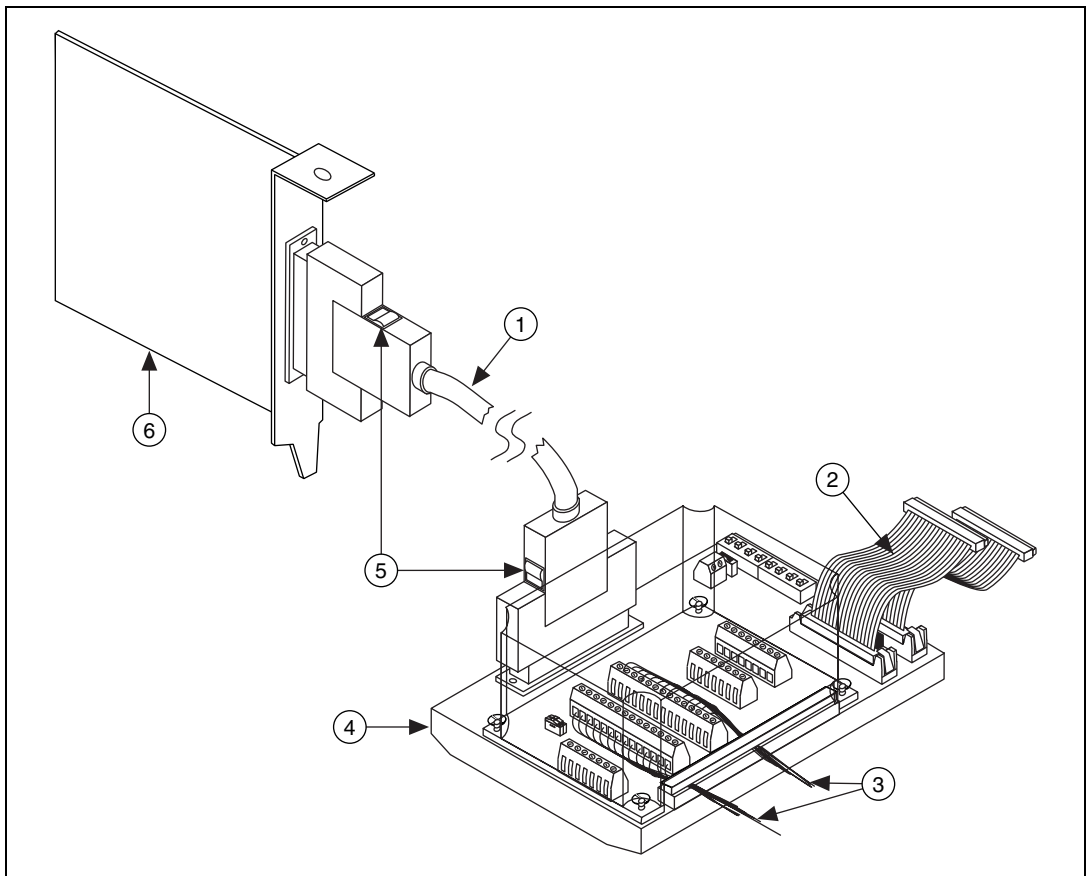
To disconnect the cable from the CB-27T and accessories from the TBX-68T or CB-68T, press outward on the ejector ears; the cable will pop out. To disconnect the SH6868 cable from the TBX-68T or CB-68T, push the two ejector ears on the backshell of the cable and gently pull on the backshell. Do *not* pull the cable.



**Caution** The connectors of both the NI 435X device and the cable are keyed for correct attachment. Do *not* force the cable when inserting it into or removing it from the NI 435X connector.

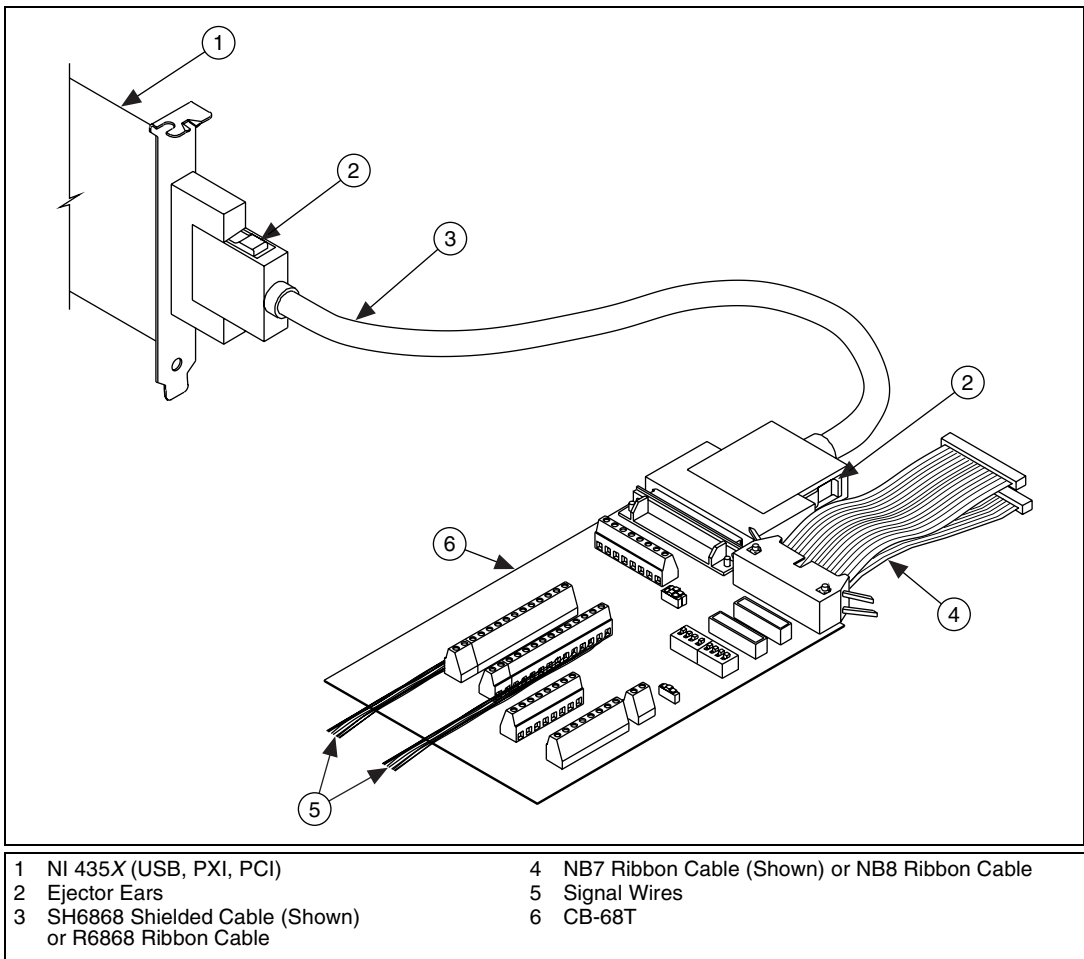


**Figure 5.** Connecting the CB-27T Cable Assembly



- |   |                           |
|---|---------------------------|
| 1 SH6868 Shielded Cable (Shown) or R6868 Ribbon Cable | 4 TBX-68T                 |
| 2 NB7 Ribbon Cable (Shown) or NB8 Ribbon Cable        | 5 Ejector Ears            |
| 3 Signal Wires  | 6 NI 435X (USB, PXI, PCI) |

**Figure 6.** Connecting the TBX-68T Cable Assembly



**Figure 7.** Connecting the CB-68T Cable Assembly

# Rack-Mounting the TBX-68T or CB-68T

---

When you have completed signal connections and terminal block installation, you can mount the TBX-68T assembly into the rack. If you are using the National Instruments TBX rack-mount assembly, refer to the *TBX Rack-Mount Kit Installation Guide* for instructions.

If you are not using this rack-mount assembly, mount the TBX assembly directly onto the DIN rail by snapping the TBX-68T bottom onto the DIN rail with a firm push.

To remove the TBX-68T from the DIN rail, place a flathead screwdriver into the slot above the terminal block base and pry it away from the rail.

If you are using the CB-68T, refer to the *CA-1000 Configurable Connector Accessory Enclosure Installation Guide* for instructions.



**Note** You cannot mount the CB-27T onto a rack.

## Using the Current Source

---

You can use the current sources on the NI 435X devices to provide excitation for RTDs, thermistors, and other resistors. Follow the instructions in the *NI 435X User Manual* to connect the signals.

The screw terminals on the terminal block labeled IEX+, IEX0+, IEX1+, IEX-, IEX0-, and IEX1- provide external access to this current source. IEX+, IEX0+, and IEX1+ are the current outputs and IEX-, IEX0-, and IEX1- are the current returns. To enable external access of the current source IEX or IEX0, push both slide switches S1 and S2, shown in Figures 2 and 3, to the *ON* position.



**Note** To measure the cold-junction temperature sensor while you are not using the current source externally through IEX+ and IEX-, push the slide switches S1 and S2 to the *OFF* position.

IEX+ and IEX- are equivalent to IEX0+ and IEX0- on the TBX-68T and CB-68T.

# Cold-Junction Temperature Sensor

---

The CB-27T, TBX-68T, and the CB-68T cold-junction temperature sensors consist of a precision thermistor powered by the 25  $\mu\text{A}$  current excitation source on the NI 435X device. At 25  $^{\circ}\text{C}$ , the resistance of the thermistor is 5,000  $\Omega$ . The thermistor resistance varies from 16,305 to 1,492  $\Omega$  over a 0–55  $^{\circ}\text{C}$  temperature range. The corresponding sensor output voltage varies from 408–37 mV over this temperature range.

To select and read the temperature sensor, refer to the software documentation for programming information.

Alternatively, you can use the following formulas to convert the cold-junction sensor voltage to cold-junction temperature:

$$T(^{\circ}\text{C}) = T_K - 273.15$$

where  $T_K$  is the temperature in kelvin.

$$T_K = \frac{1}{a + b \ln R_T + c [\ln (R_T)]^3}$$

where

$$a = 1.295361 \times 10^{-3}$$

$$b = 2.343159 \times 10^{-4}$$

$$c = 1.018703 \times 10^{-7}$$

$R_T$  = resistance of the thermistor in ohms

$$T(^{\circ}\text{F}) = \frac{[T(^{\circ}\text{C})]9}{5} + 32$$

where  $T(^{\circ}\text{F})$  and  $T(^{\circ}\text{C})$  are the temperature readings in degrees Fahrenheit and degrees Celsius, respectively.



**Note** When you have configured the NI 435X device with the correct accessory in Measurement & Automation Explorer, NI-DAQ can automatically perform cold-junction compensation on measurements taken on thermocouple channels.

# Using Digital Signal Conditioning Accessories

You can connect the TBX-68T and the CB-68T to up to two of the following accessories at one time:

- SSR 8-channel backplane for use with SSR (Solid-State Relay) Series digital signal conditioning modules
- SC-206X Series digital signal conditioning boards
- ER-8 electromechanical relay accessory

Use one of the following cable assemblies to connect these accessories to the TBX-68T or CB-68T. Refer to Table 1 for connection information.

- Use the NB8 ribbon cable for the SSR 8-channel backplane. Refer to the *SSR Series Modules and Backplanes User Guide* for more information.
- Use the NB7 ribbon cable for the SC-206X Series digital conditioning boards and the ER-8 electromechanical relay accessory. Refer to the *SC-206X Series User Manual* and the *ER-8/16 User Manual* for more information.

**Table 1.** Configuration Guide for the TBX-68T and CB-68T

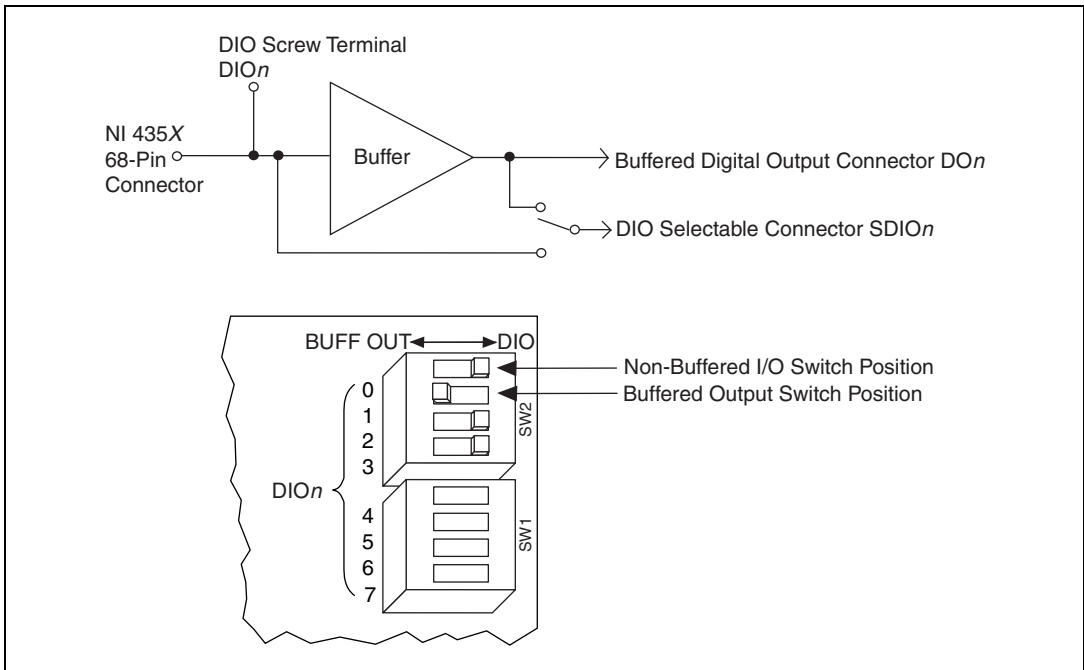
Digital Signal Conditioning Connector	Function	Accessory	Cable
Nonbuffered Individual Line Switch-Selectable Input/Output	Input	SC-2060—8 optically isolated digital inputs	NB7
		SSR-8—8 solid-state input relays	NB8
	Output	ER-8—8 low-cost electromechanical relays	NB7
		SC-2061—8 optically isolated digital outputs	NB7
		SC-2062—8 electromechanical relays	NB7
Buffered Output	Output	ER-8—8 low-cost electromechanical relays	NB7
		SC-2061—8 optically isolated digital outputs	NB7
		SC-2062—8 electromechanical relays	NB7
		SSR-8—8 solid-state output relays	NB8

Refer to Figures 3 and 4 to locate the following:

- A 26-pin individual channel, switch-selectable (SW1 and SW2) buffered output/nonbuffered I/O connector
- 26-pin buffered output connector
- Switch-selectable (S3) NI 435X/external 5 V power source for accessories screw terminal (J15)



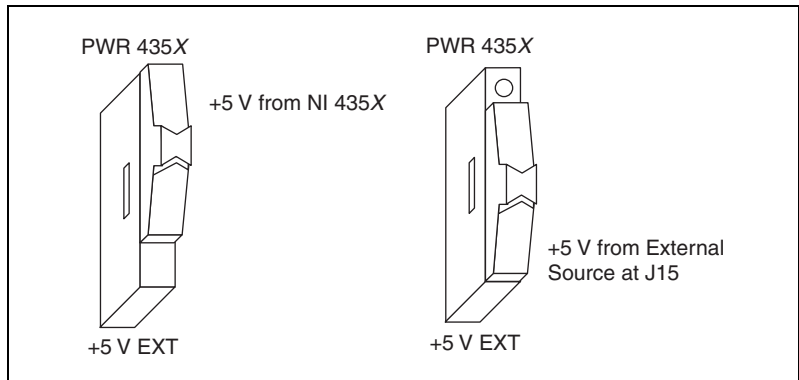
Refer to Figures 8 and 9 for switch settings.



**Figure 8.** DIO-Selectable Connector Switches (SW1 and SW2) on the TBX-68T and CB-68T



**Note** Digital input accessories attached to the DIO SELECTABLE connector control the state of the corresponding digital lines of the BUFFERED DIGITAL OUTPUT connector.



**Figure 9.** Switch-Selectable 5 V Power Source for Accessories

Figures 10 and 11 show the pin assignments for the DIO-selectable and buffered digital output 26-pin connectors.

PWR 435X/+5 V EXT	1	2	DGND
PWR 435X/+5 V EXT	3	4	DGND
PWR 435X/+5 V EXT	5	6	DGND
PWR 435X/+5 V EXT	7	8	DGND
Buffered DO 7	9	10	DGND
Buffered DO 6	11	12	DGND
Buffered DO 5	13	14	DGND
Buffered DO 4	15	16	DGND
Buffered DO 3	17	18	DGND
Buffered DO 2	19	20	DGND
Buffered DO 1	21	22	DGND
Buffered DO 0	23	24	DGND
PWR 435X/+5 V EXT	25	26	DGND

**Figure 10.** 26-Pin Buffered Digital Output Connector Pin Assignments

PWR 435X/+5 V EXT	1	2	DGND
PWR 435X/+5 V EXT	3	4	DGND
PWR 435X/+5 V EXT	5	6	DGND
PWR 435X/+5 V EXT	7	8	DGND
DIO 7/Buffered DIO 7	9	10	DGND
DIO 6/Buffered DIO 6	11	12	DGND
DIO 5/Buffered DIO 5	13	14	DGND
DIO 4/Buffered DIO 4	15	16	DGND
DIO 3/Buffered DIO 3	17	18	DGND
DIO 2/Buffered DIO 2	19	20	DGND
DIO 1/Buffered DIO 1	21	22	DGND
DIO 0/Buffered DIO 0	23	24	DGND
PWR 435X/+5 V EXT	25	26	DGND

**Figure 11.** 26-Pin DIO-Selectable Connector Pin Assignments

# Specifications

---

Cold-junction temperature sensor accuracy <sup>1</sup> .....	0.06 °C from 15 to 35 °C 0.2 °C from 0 to 15 °C and 35 to 55 °C
Isothermal accuracy .....	0.1 °C
Compatible DIN rails.....	DIN EN 50 022 DIN EN 50 035
Terminal block dimensions	
CB-27T .....	11.7 × 7.0 × 2.3 cm (4.6 × 2.75 × 0.9 in.)
TBX-68T .....	16.28 × 12.57 × 8.43 cm (6.41 × 4.95 × 3.32 in.)
CB-68T .....	16.7 × 16.5 × 3.2 cm (6.6 × 6.5 × 1.25 in.)
Max working voltage <sup>2</sup> (signal + common mode).....	Each input should remain within ±42 V of ground

## Digital Output Specifications

Max non-buffered digital I/O <sup>3</sup> .....	8 mA source/8 mA sink
Max buffered digital output .....	15 mA source/64 mA sink

## Safety

The CB-27T, TBX-68T, and CB-68T are designed to meet the requirements of the following standards for safety and electrical equipment for measurement, control, and laboratory use:

- EN 61010-1, IEC 61010-1
- UL 3111-1, UL3121-1
- CAN/CSA C22.2 No. 1010.1

---

<sup>1</sup> Includes only the thermistor accuracy. The combined effects of the temperature sensor accuracy, as well as the current source tolerances due to tolerances in all component values in the NI 435X devices, the effects caused by temperature and loading, and self-heating and current leakage are discussed in the *NI 435X User Manual*.

<sup>2</sup> Refer to the NI 435X maximum working voltage specification; use the lower number of the two.

<sup>3</sup> Refer to the *NI 435X User Manual*.

## Electromagnetic Compatibility

EMC/EMI.....	CE, C-Tick, and FCC Part 15 (Class A) Compliant
Electromagnetic emissions.....	EN 55011 Class A at 10 m FCC Part 15A above 1 GHz
Electromagnetic immunity .....	Evaluated to EN 61326:1997/ A1:1998, Table 1



**Note** For full EMC compliance, you *must* operate this device with shielded cabling. In addition, all covers and filler panels *must* be installed. Refer to the Declaration of Conformity (DoC) for this product for any additional regulatory compliance information. To obtain the DoC for this product, click **Declaration of Conformity** at [ni.com/hardref.nsf/](http://ni.com/hardref.nsf/). This Web site lists the DoCs by product family. Select the appropriate product family, followed by your product, and a link to the DoC appears in Adobe Acrobat format. Click the Acrobat icon to download or read the DoC. FCC Regulatory Compliance Statements are contained in the *Read Me First: Safety and Radio-Frequency Interference* document for this product.

## Technical Support Resources

---

### NI Web Support

National Instruments Web support is your first stop for help in solving installation, configuration, and application problems and questions. Online problem-solving and diagnostic resources include frequently asked questions, knowledge bases, product-specific troubleshooting wizards, manuals, drivers, software updates, and more. Web support is available through the Technical Support section of [ni.com](http://ni.com).

### Worldwide Support

National Instruments has offices located around the world to help address your support needs. You can access our branch office Web sites from the Worldwide Offices section of [ni.com](http://ni.com). Branch office Web sites provide up-to-date contact information, support phone numbers, email addresses, and current events.

If you have searched the technical support resources on our Web site and still cannot find the answers you need, contact your local office or National Instruments corporate. For telephone support in the United States, dial 512 795 8248. For telephone support outside the United States, contact your local branch office:

Australia 03 9879 5166, Austria 0662 45 79 90 0, Belgium 02 757 00 20,  
Brazil 55 11 3262 3599, Canada (Calgary) 403 274 9391,  
Canada (Montreal) 514 288 5722, Canada (Ottawa) 613 233 5949,  
Canada (Québec) 514 694 8521, Canada (Toronto) 905 785 0085,  
China 86 21 6555 7838, Czech Republic 02 2423 5774,  
Denmark 45 76 26 00, Finland 09 725 725 11, France 01 48 14 24 24,  
Germany 089 741 31 30, Greece 01 42 96 427, Hong Kong 2645 3186,  
India 91 80 4190000, Israel 03 6393737, Italy 02 413091,  
Japan 03 5472 2970, Korea 02 3451 3400, Malaysia 603 9596711,  
Mexico 001 800 010 0793, Netherlands 0348 433466,  
New Zealand 09 914 0488, Norway 32 27 73 00, Poland 22 3390 150,  
Portugal 210 311 210, Russia 095 238 7139, Singapore 65 6 226 5886,  
Slovenia 3 425 4200, South Africa 11 805 8197, Spain 91 640 0085,  
Sweden 08 587 895 00, Switzerland 056 200 51 51,  
Taiwan 02 2528 7227, United Kingdom 01635 523545



321613D-01

Oct02