

## COMPREHENSIVE SERVICES

We offer competitive repair and calibration services, as well as easily accessible documentation and free downloadable resources.

## SELL YOUR SURPLUS

We buy new, used, decommissioned, and surplus parts from every NI series. We work out the best solution to suit your individual needs.

 Sell For Cash    Get Credit    Receive a Trade-In Deal

## OBSOLETE NI HARDWARE IN STOCK & READY TO SHIP

We stock **New**, **New Surplus**, **Refurbished**, and **Reconditioned** NI Hardware.



*Bridging the gap between the manufacturer and your legacy test system.*

 1-800-915-6216

 [www.apexwaves.com](http://www.apexwaves.com)

 [sales@apexwaves.com](mailto:sales@apexwaves.com)

*All trademarks, brands, and brand names are the property of their respective owners.*

**Request a Quote**

 **CLICK HERE**

**DAQCard-1200**

# DAQ

---

## DAQCard™ -1200 User Manual

Multifunction I/O Card for  
the PCMCIA Bus

## **Worldwide Technical Support and Product Information**

ni.com

## **National Instruments Corporate Headquarters**

11500 North Mopac Expressway Austin, Texas 78759-3504 USA Tel: 512 683 0100

## **Worldwide Offices**

Australia 03 9879 5166, Austria 0662 45 79 90 0, Belgium 02 757 00 20, Brazil 011 3262 3599,  
Canada (Calgary) 403 274 9391, Canada (Montreal) 514 288 5722, Canada (Ottawa) 613 233 5949,  
Canada (Québec) 514 694 8521, Canada (Toronto) 905 785 0085, China (Shanghai) 021 6555 7838,  
China (ShenZhen) 0755 3904939, Czech Republic 02 2423 5774, Denmark 45 76 26 00, Finland 09 725 725 11,  
France 01 48 14 24 24, Germany 089 741 31 30, Greece 30 1 42 96 427, Hong Kong 2645 3186,  
India 91 80 535 5406, Israel 03 6393737, Italy 02 413091, Japan 03 5472 2970, Korea 02 3451 3400,  
Malaysia 603 9596711, Mexico 001 800 010 0793, Netherlands 0348 433466, New Zealand 09 914 0488,  
Norway 32 27 73 00, Poland 0 22 528 94 06, Portugal 351 210 311 210, Russia 095 238 7139,  
Singapore 2265886, Slovenia 386 3 425 4200, South Africa 11 805 8197, Spain 91 640 0085,  
Sweden 08 587 895 00, Switzerland 056 200 51 51, Taiwan 02 2528 7227, United Kingdom 01635 523545

For further support information, see the *Technical Support Resources* appendix. To comment on the documentation, send e-mail to [techpubs@ni.com](mailto:techpubs@ni.com).

# Important Information

---

## Warranty

The DAQCard-1200 is warranted against defects in materials and workmanship for a period of one year from the date of shipment, as evidenced by receipts or other documentation. National Instruments will, at its option, repair or replace equipment that proves to be defective during the warranty period. This warranty includes parts and labor.

The media on which you receive National Instruments software are warranted not to fail to execute programming instructions, due to defects in materials and workmanship, for a period of 90 days from date of shipment, as evidenced by receipts or other documentation. National Instruments will, at its option, repair or replace software media that do not execute programming instructions if National Instruments receives notice of such defects during the warranty period. National Instruments does not warrant that the operation of the software shall be uninterrupted or error free.

A Return Material Authorization (RMA) number must be obtained from the factory and clearly marked on the outside of the package before any equipment will be accepted for warranty work. National Instruments will pay the shipping costs of returning to the owner parts which are covered by warranty.

National Instruments believes that the information in this document is accurate. The document has been carefully reviewed for technical accuracy. In the event that technical or typographical errors exist, National Instruments reserves the right to make changes to subsequent editions of this document without prior notice to holders of this edition. The reader should consult National Instruments if errors are suspected. In no event shall National Instruments be liable for any damages arising out of or related to this document or the information contained in it.

EXCEPT AS SPECIFIED HEREIN, NATIONAL INSTRUMENTS MAKES NO WARRANTIES, EXPRESS OR IMPLIED, AND SPECIFICALLY DISCLAIMS ANY WARRANTY OF MERCHANTABILITY OR FITNESS FOR A PARTICULAR PURPOSE. CUSTOMER'S RIGHT TO RECOVER DAMAGES CAUSED BY FAULT OR NEGLIGENCE ON THE PART OF NATIONAL INSTRUMENTS SHALL BE LIMITED TO THE AMOUNT THERETOFORE PAID BY THE CUSTOMER. NATIONAL INSTRUMENTS WILL NOT BE LIABLE FOR DAMAGES RESULTING FROM LOSS OF DATA, PROFITS, USE OF PRODUCTS, OR INCIDENTAL OR CONSEQUENTIAL DAMAGES, EVEN IF ADVISED OF THE POSSIBILITY THEREOF. This limitation of the liability of National Instruments will apply regardless of the form of action, whether in contract or tort, including negligence. Any action against National Instruments must be brought within one year after the cause of action accrues. National Instruments shall not be liable for any delay in performance due to causes beyond its reasonable control. The warranty provided herein does not cover damages, defects, malfunctions, or service failures caused by owner's failure to follow the National Instruments installation, operation, or maintenance instructions; owner's modification of the product; owner's abuse, misuse, or negligent acts; and power failure or surges, fire, flood, accident, actions of third parties, or other events outside reasonable control.

## Copyright

Under the copyright laws, this publication may not be reproduced or transmitted in any form, electronic or mechanical, including photocopying, recording, storing in an information retrieval system, or translating, in whole or in part, without the prior written consent of National Instruments Corporation.

## Trademarks

CVI™, DAQCard™, DAQPad™, LabVIEW™, Measurement Studio™, National Instruments™, NI™, ni.com™, and NI-DAQ™ are trademarks of National Instruments Corporation.

Product and company names mentioned herein are trademarks or trade names of their respective companies.

## Patents

For patents covering National Instruments products, refer to the appropriate location: **Help»Patents** in your software, the `patents.txt` file on your CD, or [ni.com/patents](http://ni.com/patents).

## WARNING REGARDING USE OF NATIONAL INSTRUMENTS PRODUCTS

(1) NATIONAL INSTRUMENTS PRODUCTS ARE NOT DESIGNED WITH COMPONENTS AND TESTING FOR A LEVEL OF RELIABILITY SUITABLE FOR USE IN OR IN CONNECTION WITH SURGICAL IMPLANTS OR AS CRITICAL COMPONENTS IN ANY LIFE SUPPORT SYSTEMS WHOSE FAILURE TO PERFORM CAN REASONABLY BE EXPECTED TO CAUSE SIGNIFICANT INJURY TO A HUMAN.

(2) IN ANY APPLICATION, INCLUDING THE ABOVE, RELIABILITY OF OPERATION OF THE SOFTWARE PRODUCTS CAN BE IMPAIRED BY ADVERSE FACTORS, INCLUDING BUT NOT LIMITED TO FLUCTUATIONS IN ELECTRICAL POWER SUPPLY, COMPUTER HARDWARE MALFUNCTIONS, COMPUTER OPERATING SYSTEM SOFTWARE FITNESS, FITNESS OF COMPILERS AND DEVELOPMENT SOFTWARE USED TO DEVELOP AN APPLICATION, INSTALLATION ERRORS, SOFTWARE AND HARDWARE COMPATIBILITY PROBLEMS, MALFUNCTIONS OR FAILURES OF ELECTRONIC MONITORING OR CONTROL DEVICES, TRANSIENT FAILURES OF ELECTRONIC SYSTEMS (HARDWARE AND/OR SOFTWARE), UNANTICIPATED USES OR MISUSES, OR ERRORS ON THE PART OF THE USER OR APPLICATIONS DESIGNER (ADVERSE FACTORS SUCH AS THESE ARE HEREAFTER COLLECTIVELY TERMED "SYSTEM FAILURES"). ANY APPLICATION WHERE A SYSTEM FAILURE WOULD CREATE A RISK OF HARM TO PROPERTY OR PERSONS (INCLUDING THE RISK OF BODILY INJURY AND DEATH) SHOULD NOT BE RELIANT SOLELY UPON ONE FORM OF ELECTRONIC SYSTEM DUE TO THE RISK OF SYSTEM FAILURE. TO AVOID DAMAGE, INJURY, OR DEATH, THE USER OR APPLICATION DESIGNER MUST TAKE REASONABLY PRUDENT STEPS TO PROTECT AGAINST SYSTEM FAILURES, INCLUDING BUT NOT LIMITED TO BACK-UP OR SHUT-DOWN MECHANISMS. BECAUSE EACH END-USER SYSTEM IS CUSTOMIZED AND DIFFERS FROM NATIONAL INSTRUMENTS' TESTING PLATFORMS AND BECAUSE A USER OR APPLICATION DESIGNER MAY USE NATIONAL INSTRUMENTS PRODUCTS IN COMBINATION WITH OTHER PRODUCTS IN A MANNER NOT EVALUATED OR CONTEMPLATED BY NATIONAL INSTRUMENTS, THE USER OR APPLICATION DESIGNER IS ULTIMATELY RESPONSIBLE FOR VERIFYING AND VALIDATING THE SUITABILITY OF NATIONAL INSTRUMENTS PRODUCTS WHENEVER NATIONAL INSTRUMENTS PRODUCTS ARE INCORPORATED IN A SYSTEM OR APPLICATION, INCLUDING, WITHOUT LIMITATION, THE APPROPRIATE DESIGN, PROCESS AND SAFETY LEVEL OF SUCH SYSTEM OR APPLICATION.

# Compliance

---

## FCC/Canada Radio Frequency Interference Compliance\*

### Determining FCC Class

The Federal Communications Commission (FCC) has rules to protect wireless communications from interference. The FCC places digital electronics into two classes. These classes are known as Class A (for use in industrial-commercial locations only) or Class B (for use in residential or commercial locations). Depending on where it is operated, this product could be subject to restrictions in the FCC rules. (In Canada, the Department of Communications (DOC), of Industry Canada, regulates wireless interference in much the same way.)

Digital electronics emit weak signals during normal operation that can affect radio, television, or other wireless products. By examining the product you purchased, you can determine the FCC Class and therefore which of the two FCC/DOC Warnings apply in the following sections. (Some products may not be labeled at all for FCC; if so, the reader should then assume these are Class A devices.)

FCC Class A products only display a simple warning statement of one paragraph in length regarding interference and undesired operation. Most of our products are FCC Class A. The FCC rules have restrictions regarding the locations where FCC Class A products can be operated.

FCC Class B products display either a FCC ID code, starting with the letters **EXN**, or the FCC Class B compliance mark that appears as shown here on the right.

Consult the FCC Web site at [fcc.gov](http://fcc.gov) for more information.

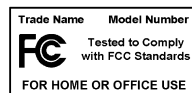

### FCC/DOC Warnings

This equipment generates and uses radio frequency energy and, if not installed and used in strict accordance with the instructions in this manual and the CE Mark Declaration of Conformity\*\*, may cause interference to radio and television reception. Classification requirements are the same for the FCC and the DOC.

Changes or modifications not expressly approved by National Instruments could void the user's authority to operate the equipment under the FCC Rules.

### Class A

#### Federal Communications Commission

This equipment has been tested and found to comply with the limits for a Class A digital device, pursuant to part 15 of the FCC Rules. These limits are designed to provide reasonable protection against harmful interference when the equipment is operated in a commercial environment. This equipment generates, uses, and can radiate radio frequency energy and, if not installed and used in accordance with the instruction manual, may cause harmful interference to radio communications. Operation of this equipment in a residential area is likely to cause harmful interference in which case the user will be required to correct the interference at his own expense.

#### Canadian Department of Communications

This Class A digital apparatus meets all requirements of the Canadian Interference-Causing Equipment Regulations.

Cet appareil numérique de la classe A respecte toutes les exigences du Règlement sur le matériel brouilleur du Canada.

### Class B

#### Federal Communications Commission

This equipment has been tested and found to comply with the limits for a Class B digital device, pursuant to part 15 of the FCC Rules. These limits are designed to provide reasonable protection against harmful interference in a residential installation. This equipment generates, uses, and can radiate radio frequency energy and, if not installed and used in accordance with the instructions, may cause harmful interference to radio communications. However, there is no guarantee that interference will not occur in a particular installation. If this equipment does cause harmful interference to radio or television reception, which can be determined by turning the equipment off and on, the user is encouraged to try to correct the interference by one or more of the following measures:

- Reorient or relocate the receiving antenna.
- Increase the separation between the equipment and receiver.
- Connect the equipment into an outlet on a circuit different from that to which the receiver is connected.
- Consult the dealer or an experienced radio/TV technician for help.

## Canadian Department of Communications

This Class B digital apparatus meets all requirements of the Canadian Interference-Causing Equipment Regulations.

Cet appareil numérique de la classe B respecte toutes les exigences du Règlement sur le matériel brouilleur du Canada.

## Compliance to EU Directives

Readers in the European Union (EU) must refer to the Manufacturer's Declaration of Conformity (DoC) for information\*\* pertaining to the CE Mark compliance scheme. The Manufacturer includes a DoC for most every hardware product except for those bought for OEMs, if also available from an original manufacturer that also markets in the EU, or where compliance is not required as for electrically benign apparatus or cables.

To obtain the DoC for this product, click **Declaration of Conformity** at [ni.com/hardref.nsf/](http://ni.com/hardref.nsf/). This Web site lists the DoCs by product family. Select the appropriate product family, followed by your product, and a link to the DoC appears in Adobe Acrobat format. Click the Acrobat icon to download or read the DoC.

\* Certain exemptions may apply in the USA, see FCC Rules §15.103 **Exempted devices**, and §15.105(c). Also available in sections of CFR 47.

\*\* The CE Mark Declaration of Conformity will contain important supplementary information and instructions for the user or installer.

# Contents

---

## About This Manual

Conventions .....	xi
National Instruments Documentation .....	xii

## Chapter 1

### Introduction

About the DAQCard-1200 .....	1-1
What You Need to Get Started .....	1-2
Software Programming Choices .....	1-2
NI-DAQ .....	1-2
National Instruments ADE Software .....	1-4
Optional Equipment .....	1-4
Unpacking .....	1-5
Safety Information .....	1-5

## Chapter 2

### Installing and Configuring the DAQCard-1200

Installing the Software .....	2-1
Installing the Hardware .....	2-1
Configuring the DAQCard-1200 .....	2-3
Configuring Analog Input .....	2-3
Analog Input Polarity .....	2-4
Analog Input Mode .....	2-4
DIFF Input Mode (Four Channels) .....	2-4
RSE Input Mode (Eight Channels, Default Setting) .....	2-5
NRSE Input Mode (Eight Channels) .....	2-5
Configuring Analog Output .....	2-5
Analog Output Polarity .....	2-6
Configuring Digital I/O .....	2-6
Configuring Counters .....	2-6

## Chapter 3 Connecting the Signals

I/O Connector .....	3-1
Signal Connection Descriptions .....	3-3
Connecting Analog Input Signals .....	3-4
Types of Signal Sources .....	3-6
Floating Signal Sources.....	3-6
Ground-Referenced Signal Sources .....	3-6
Input Configurations.....	3-7
Differential Connection Considerations	
(DIFF Input Mode).....	3-7
Single-Ended Connection Considerations	
(RSE and NRSE Input Modes).....	3-11
Common-Mode Signal Rejection Considerations.....	3-13
Connecting Analog Output Signals.....	3-14
Connecting Digital I/O Signals .....	3-15
Port C Pin Connections.....	3-17
Timing Specifications.....	3-18
Mode 1 Input Timing .....	3-19
Mode 1 Output Timing.....	3-20
Mode 2 Bidirectional Timing.....	3-20
Connecting Analog I/O and General-Purpose Timing Signals.....	3-22
Analog Input Timing Connections .....	3-22
Analog Output Timing Connections.....	3-26
General-Purpose Timing Connections.....	3-27
Connecting the Power .....	3-31

## Chapter 4 Theory of Operation

Functional Overview .....	4-1
PC Card I/O Channel Interface Circuitry .....	4-2
Timing .....	4-3
Analog Input.....	4-5
Analog Input Circuitry .....	4-6
Data Acquisition Timing.....	4-8
Data Acquisition Operation .....	4-8
Round-Robin Data Acquisition .....	4-8
Interval Data Acquisition.....	4-8
Data Acquisition Rates.....	4-9



Analog Output.....	4-10
Analog Output Circuitry.....	4-10
Power-On State.....	4-11
DAC Timing.....	4-11
Digital I/O.....	4-12

## **Chapter 5**

### **Calibration**

Loading Calibration Constants .....	5-1
Self-Calibration.....	5-2
External Calibration.....	5-2

## **Appendix A**

### **Specifications**

## **Appendix B**

### **Differences among the Lab-PC+, the DAQPad-1200, and the DAQ-Card-1200**

## **Appendix C**

### **Common Questions**

## **Appendix D**

### **Technical Support Resources**

## **Glossary**

## **Index**

# About This Manual

---

This manual describes the mechanical and electrical aspects of the National Instruments (NI) DAQCard-1200 and contains information concerning its installation and operation. The DAQCard-1200 is a compact, low-cost, low-power analog input (AI), analog output (AO), digital I/O (DIO), and timing I/O (TIO) card for IBM PC/XT, PC AT, and compatible computers that are equipped with a PCMCIA Type II PC Card socket.

## Conventions

---

The following conventions appear in this manual:

<>

Angle brackets that contain numbers separated by an ellipsis represent a range of values associated with a bit or signal name—for example, DBIO<3..0>.

»

The» symbol leads you through nested menu items and dialog box options to a final action. The sequence **File»Page Setup»Options** directs you to pull down the **File** menu, select the **Page Setup** item, and select **Options** from the last dialog box.



This icon denotes a note, which alerts you to important information.



This icon denotes a caution, which advises you of precautions to take to avoid injury, data loss, or a system crash. When this symbol is marked on the product, refer to the *Safety Information* section of Chapter 1, *Introduction*, for precautions to take.

**bold**

Bold text denotes items that you must select or click on in the software, such as menu items and dialog box options. Bold text also denotes parameter names.

*italic*

Italic text denotes variables, emphasis, a cross reference, or an introduction to a key concept. This font also denotes text that is a placeholder for a word or value that you must supply.

monospace

Text in this font denotes text or characters that you should enter from the keyboard, sections of code, programming examples, and syntax examples. This font is also used for the proper names of disk drives, paths, directories, programs, subprograms, subroutines, device names, functions, operations, variables, filenames and extensions, and code excerpts.

<b>PC</b>	PC refers to all PC AT series computers with PCI or PXI bus unless otherwise noted.
<b>PCMCIA</b>	PCMCIA is an international standards body and trade association that promotes the interoperability of PC cards.
<b>Platform</b>	Text in this font denotes a specific platform and indicates that the text following it applies only to that platform.

## National Instruments Documentation

---

The *DAQCard-1200 User Manual* is one piece of the documentation set for the data acquisition (DAQ) system. You could have any of several types of documentation depending on the hardware and software in your system.

Use the documentation you have as follows:

- **Hardware documentation**—This documentation has detailed information about the DAQ hardware that plugs into or is connected to the computer. Use this documentation for hardware installation and configuration instructions, specification information about DAQ hardware, and application hints.
- **Software documentation**—You may have both application software and NI-DAQ software documentation. NI application software includes LabVIEW and Measurement Studio. After you set up your hardware system, use either your application software documentation or the NI-DAQ documentation to help you write your application. If you have a large, complicated system, it is worthwhile to look through the software documentation before you configure your hardware.
- **Accessory installation guides or manuals**—If you are using accessory products, read the cable assembly installation guide. It explains how to physically connect the relevant pieces of the system. Consult this guide when you make the connections.

---

# Introduction

This chapter discusses what you need to get started, optional software, optional equipment, how to unpack the DAQCard-1200, and safety information for using the device.

## About the DAQCard-1200

---

The DAQCard-1200 is a low-cost, low-power AI, AO, DIO, and TIO card for computers equipped with a Type II PC Card slot. The card contains a 12-bit, successive-approximation A/D converter (ADC) with eight inputs, which you can configure as eight single-ended or four differential channels. The DAQCard-1200 also has two 12-bit D/A converters (DACs) with voltage outputs, 24 lines of TTL-compatible DIO and three 16-bit counter/timer channels for TIO. The specially designed standard 50-pin I/O connector for the DAQCard-1200 enables you to connect all the analog, digital, and timing signals to the card. The DAQCard-1200 is fully software configurable and factory calibrated so that you can easily install the card and begin acquiring data.

The low power consumption of the DAQCard-1200 makes this card ideal for use in portable computers and makes portable data acquisition practical. The card requires very little power when operating, thus extending the life of your computer batteries.

In addition, the low-cost and multifunctional nature of a system based on the DAQCard-1200 makes it ideal for laboratory work in industrial and academic environments. The multiple channel analog input is useful in signal analysis and data logging. The 12-bit ADC is useful in high-resolution applications such as chromatography, temperature measurement, and DC voltage measurement. You can use the AO channels to generate experimental stimuli or for machine and process control and analog function generation. You can use the 24 TTL-compatible DIO lines for switching external devices such as transistors and solid-state relays, for reading the status of external digital logic, and for generating interrupts. You can use the counter/timers to synchronize events, generate pulses, and measure frequency and time. The DAQCard-1200, used in conjunction

with the PC, is a versatile, cost-effective and portable platform for laboratory test, measurement, and control.

The DAQCard-1200 is shipped with NI-DAQ, the NI driver software that handles every function listed on the data sheet for our hardware. Using NI-DAQ, you can start your application quickly and easily without having to program the card at the register level. Utilities shipped with NI-DAQ also can help you conserve additional power by configuring the DAQCard-1200 in the power-down mode.

Detailed specifications of the DAQCard-1200 are in Appendix A, [Specifications](#).

## What You Need to Get Started

---

To set up and use the DAQCard-1200, you need the following items:

- DAQCard-1200
- DAQCard-1200 I/O cable
- DAQCard-1200 User Manual*
- One of the following software packages and documentation:
  - LabVIEW (**for Windows or Mac OS**)
  - Measurement Studio (**for Windows**)
- NI-DAQ (**for PC compatibles or Mac OS**)
- The computer

## Software Programming Choices

---

When programming NI data acquisition (DAQ) hardware, you can use NI application development environment (ADE) software or other ADEs. In either case, you use NI-DAQ.

### NI-DAQ

NI-DAQ, which shipped with the DAQCard-1200, has an extensive library of functions that you can call from your ADE. These functions allow you to use all the features of the DAQCard-1200.

NI-DAQ carries out many of the complex interactions, such as programming interrupts, between the computer and the DAQ hardware. NI-DAQ maintains a consistent software interface among its different versions so that you can change platforms with minimal modifications to your code. Whether you use LabVIEW, Measurement Studio, or other ADEs, your application uses NI-DAQ, as illustrated in Figure 1-1.

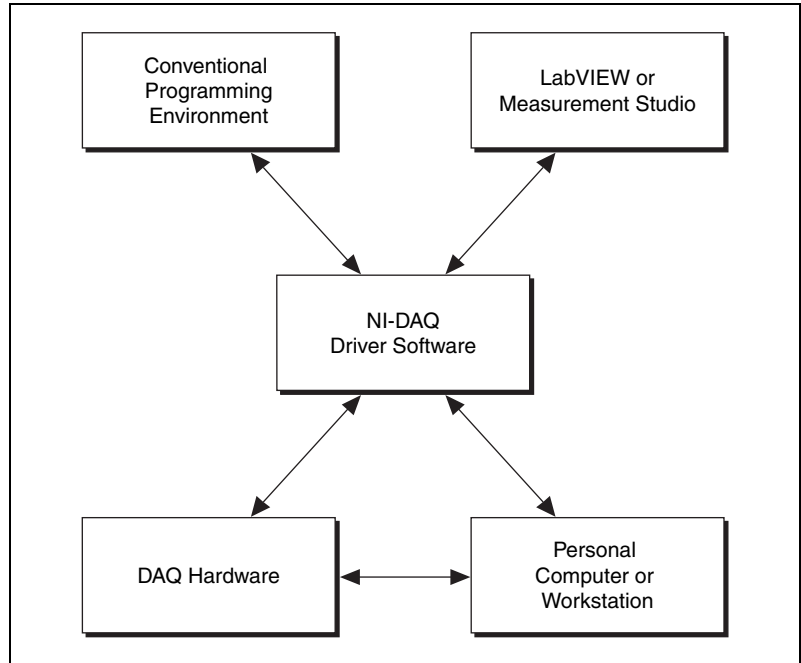

**Figure 1-1.** The Relationship Between the Programming Environment, NI-DAQ, and the Hardware

To download a free copy of the most recent version of NI-DAQ, click **Download Software** at [ni.com](http://ni.com).

## National Instruments ADE Software

LabVIEW features interactive graphics, a state-of-the-art interface, and a powerful graphical programming language. The LabVIEW Data Acquisition VI Library, a series of virtual instruments (VIs) for using LabVIEW with National Instruments DAQ hardware, is included with LabVIEW.

Measurement Studio, which includes LabWindows/CVI, tools for Visual C++, and tools for Visual Basic, is a development suite that allows you to use ANSI C, Visual C++, and Visual Basic to design your test and measurement software. For C developers, Measurement Studio includes LabWindows/CVI, a fully integrated ANSI C application development environment that features interactive graphics and the LabWindows/CVI Data Acquisition and Easy I/O libraries. For Visual Basic developers, Measurement Studio features a set of ActiveX controls for using National Instruments DAQ hardware. These ActiveX controls provide a high-level programming interface for building virtual instruments. For Visual C++ developers, Measurement Studio offers a set of Visual C++ classes and tools to integrate those classes into Visual C++ applications. The libraries, ActiveX controls, and classes are available with Measurement Studio and NI-DAQ.

Using LabVIEW or Measurement Studio greatly reduces the development time for your data acquisition and control application.

## Optional Equipment

---

NI offers a variety of products to use with the DAQCard-1200, including cables, connector blocks, and other accessories, including the following items:

- BNC-2081
- CB-50 or CB-50LP I/O connector block with a 0.5 or 1.0 m cable
- ER-8, ER-16 electromechanical relays
- PR50-50F or PR50-50M cables
- SC-2042, SC-2043 strain gauge and resistance-temperature detector (RTD) accessories
- SCXI products

For more specific information about these products, refer to [ni.com/catalog](http://ni.com/catalog) or call the office nearest you.

# Unpacking

---

The DAQCard-1200 is shipped in an antistatic package to prevent electrostatic damage to the device.



**Caution** *Never* touch the exposed pins of connectors.

Because the DAQCard-1200 is enclosed in a fully shielded case, no additional electrostatic precautions are necessary.

Remove the DAQCard-1200 from the package and inspect the device for loose components or any sign of damage. Notify NI if the DAQCard-1200 appears damaged in any way. Do *not* install a damaged device into your computer.

Store the DAQCard-1200 in the antistatic envelope when not in use.

## Safety Information

---

The following section contains important safety instructions that you *must* follow when installing and using the product.

Do *not* operate the product in a manner not specified in this document. Misuse of the product can result in a hazard. You can compromise the safety protection built into the product if the product is damaged in any way. If the product is damaged, return it to NI for repair.

Do *not* substitute parts or modify the product except as described in this document. Use the product only with the chassis, modules, accessories, and cables specified in the installation instructions. You *must* have all covers and filler panels installed during operation of the product.

Do *not* operate the product in an explosive atmosphere or where there may be flammable gases or fumes. Operate the product only at or below the pollution degree stated in Appendix A, *Specifications*. Pollution is foreign matter in a solid, liquid, or gaseous state that can reduce dielectric strength or surface resistivity. The following is a description of pollution degrees:

- Pollution degree 1 means no pollution or only dry, nonconductive pollution occurs. The pollution has no influence.
- Pollution degree 2 means that only nonconductive pollution occurs in most cases. Occasionally, however, a temporary conductivity caused by condensation must be expected.



- Pollution degree 3 means that conductive pollution occurs, or dry, nonconductive pollution occurs that becomes conductive due to condensation.

Clean the product with a soft nonmetallic brush. Make sure that the product is completely dry and free from contaminants before returning it to service.

You *must* insulate signal connections for the maximum voltage for which the product is rated. Do *not* exceed the maximum ratings for the product. Remove power from signal lines before connecting them to or disconnecting them from the product.

Operate this product only at or below the installation category stated in Appendix A, *Specifications*.

The following is a description of installation categories:

- Installation category I is for measurements performed on circuits not directly connected to MAINS<sup>1</sup>. This category is a signal level such as voltages on a printed wire board (PWB) on the secondary of an isolation transformer.

Examples of installation category I are measurements on circuits not derived from MAINS and specially protected (internal) MAINS-derived circuits.

- Installation category II is for measurements performed on circuits directly connected to the low-voltage installation. This category refers to local-level distribution such as that provided by a standard wall outlet.

Examples of installation category II are measurements on household appliances, portable tools, and similar equipment.

- Installation category III is for measurements performed in the building installation. This category is a distribution level referring to hardwired equipment that does not rely on standard building insulation.

Examples of installation category III include measurements on distribution circuits and circuit breakers. Other examples of installation category III are wiring including cables, bus-bars, junction boxes, switches, socket outlets in the building/fixed installation, and equipment for industrial use, such as stationary motors with a permanent connection to the building/fixed installation.

---

<sup>1</sup> MAINS is defined as the electricity supply system to which the equipment concerned is designed to be connected either for powering the equipment or for measurement purposes.

- Installation category IV is for measurements performed at the source of the low-voltage (<1,000 V) installation.

Examples of category IV are electric meters, and measurements on primary overcurrent protection devices and ripple-control units.

Below is a diagram of a sample installation.

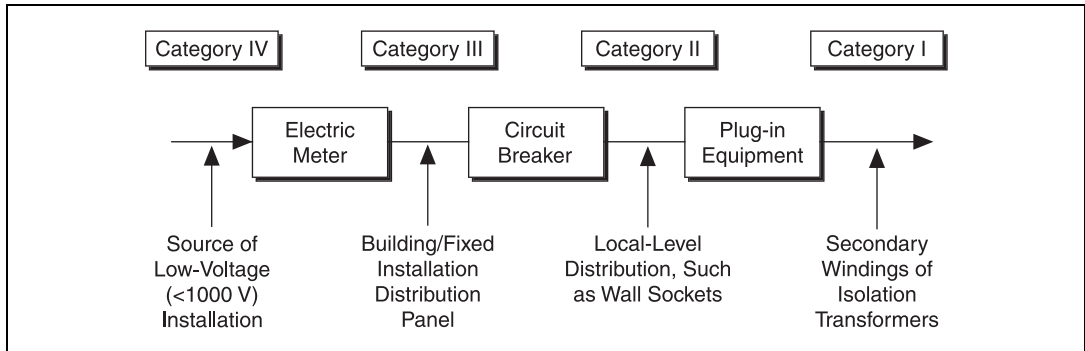

---

# Installing and Configuring the DAQCard-1200

This chapter describes how to install and configure the DAQCard-1200.

---

## Installing the Software

Install the software before you install the DAQCard-1200. Install the ADE, such as LabVIEW or Measurement Studio, according to the instructions on the CD and the release notes. After you have installed the ADE, install NI-DAQ according to the instructions on the CD and the *DAQ Quick Start Guide* included with the DAQCard-1200.



**Note** It is important to install NI-DAQ before installing the DAQCard-1200 to ensure that the DAQCard-1200 is properly detected.

---

## Installing the Hardware

The following are general installation instructions. Consult the computer user manual or technical reference manual for specific instructions and warnings about installing new devices. Refer to Figure 2-1 when installing the DAQCard-1200.

1. Power off and unplug the computer.



**Note** You must have Card & Socket Services 2.0 or later on the computer.

2. Insert the PCMCIA bus connector of the DAQCard-1200 in any available Type II PC Card slot until the connector is firmly seated. The DAQCard-1200 has two connectors—a 68-pin PCMCIA bus connector on one end and a 50-pin I/O connector on the other end. Notice that the card is keyed so that it can be inserted only one way.



**Note** If the computer supports hot-swapping, you may insert or remove the DAQCard-1200 at any time, whether the computer is powered on or off.

3. Visually verify the installation by making sure that the DAQCard-1200 is fully inserted into the slot.
4. Attach the I/O cable. You can use either a 50-pin female or a 50-pin male cable to plug into the DAQCard-1200. For more information on these products, refer to the *Optional Equipment* section in Chapter 1, *Introduction*. Notice that the cable is keyed so that you can insert it only one way.



**Note** Be careful not to put strain on the I/O cable when inserting it into and removing it from the DAQCard-1200. Always grasp the cable by the connector you are plugging or unplugging. *Never* pull directly on the I/O cable to unplug it from the DAQCard-1200.

5. Plug in and power on the computer.

The DAQCard-1200 is now installed. You are now ready to configure the hardware and software and to make the appropriate connections to the I/O connector cable as described in Chapter 3, *Connecting the Signals*.

Figure 2-1 shows an example of a typical configuration.

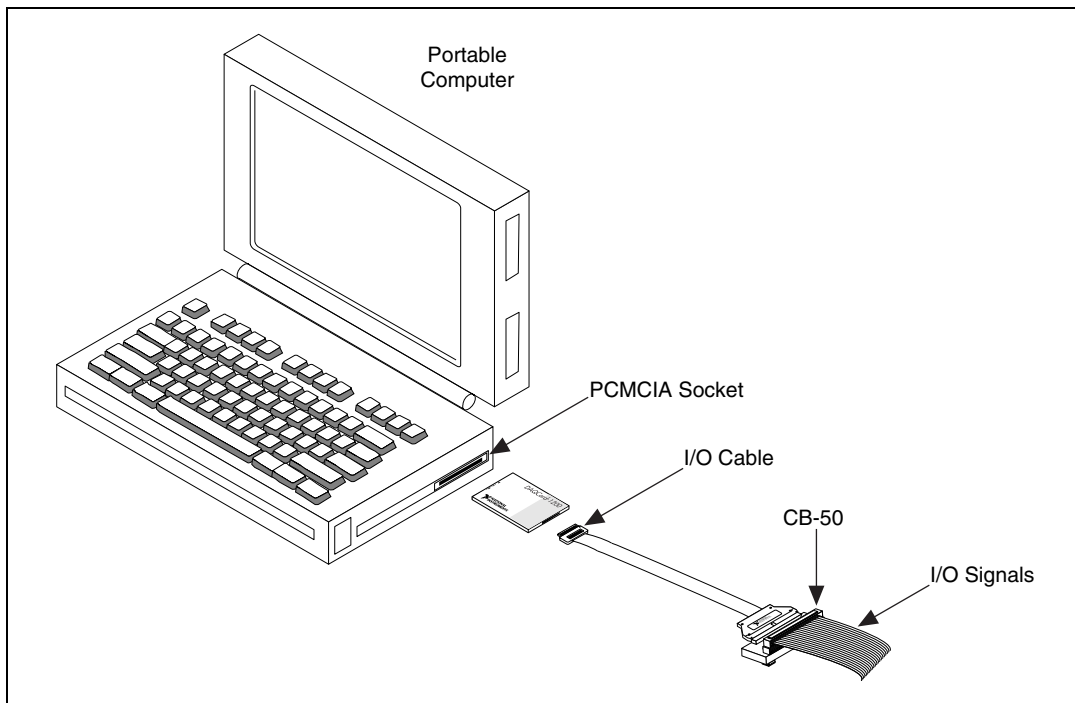

**Figure 2-1.** A Typical Configuration for the DAQCard-1200

# Configuring the DAQCard-1200

Because of the NI standard architecture for data acquisition, the DAQCard-1200 is completely software configurable.

Data acquisition-related configuration, which you must perform, includes such settings as analog input coupling and range, and others. You can modify these settings using NI-DAQ or application-level software, such as LabVIEW and Measurement Studio.

To configure the device in Measurement & Automation Explorer (MAX), refer to either the *DAQ Quick Start Guide* or to the *NI-DAQ User Manual for PC Compatibles*.

## Configuring Analog Input

At startup, the DAQCard-1200 defaults to the following configuration:

- Referenced single-ended input mode
- $\pm 5$  V AI range

Table 2-1 lists the available AI configurations for the DAQCard-1200 and shows the default settings.

**Table 2-1.** Analog Input Settings

Parameter	Configuration
Analog Input Polarity	Bipolar— $\pm 5$ V (default setting) Unipolar—0–10 V
Analog Input Mode	Referenced single-ended (RSE) (default setting) Non-referenced single-ended (NRSE) Differential (DIFF)

The analog input circuitry is software configurable.



**Caution** Connections, including power signals to ground and vice versa, that exceed any of the maximum signal ratings on the DAQCard-1200 can damage the card and computer. NI is *not* liable for any injuries or damage resulting from incorrect signal connections.

## Analog Input Polarity

You can configure the AI setting on the DAQCard-1200 for either a unipolar range (0 to 10 V) or a bipolar range (–5 to +5 V). If you select a bipolar range, the two’s complement coding mode is selected. In this mode, –5 V input corresponds to F800 hex (–2,048 decimal) and +5 V corresponds to 7FF hex (2,047 decimal). If you select a unipolar mode, the straight binary coding is selected. In this mode, 0 V input corresponds to 0 hex, and +10 V corresponds to FFF hex (4,095 decimal).

## Analog Input Mode

The DAQCard-1200 has three input modes—RSE, NRSE, and DIFF. The single-ended modes, RSE and NRSE, provide eight input channels. DIFF input mode provides four input channels. Table 2-2 describes these modes.

**Table 2-2.** Analog Input Modes for the DAQCard-1200

Analog Input Modes	Description
DIFF	DIFF mode provides four differential inputs with the positive input of the instrumentation amplifier tied to channels 0, 2, 4, or 6 and the negative input tied to channels 1, 3, 5, or 7, respectively, thus pairing channels (0, 1), (2, 3), (4, 5), (6, 7).
RSE	RSE mode provides eight single-ended inputs with the negative input of the instrumentation amplifier referenced to AISENSE/AIGND, which is tied to ground through about 200 $\Omega$ resistance (default setting).
NRSE	NRSE mode provides eight single-ended inputs with the negative input of the instrumentation amplifier tied to AISENSE/AIGND, which is not connected to ground.

While reading the following paragraphs, you may find it helpful to refer to the [Connecting Analog Input Signals](#) section of Chapter 3, [Connecting the Signals](#), which contains diagrams showing the signal paths for the three modes. These three modes are software-selectable.

### DIFF Input Mode (Four Channels)

DIFF input mode means that each input signal has its own reference, and the difference between each signal and its reference is measured. The signal and its reference are each assigned an input channel. With DIFF input mode, the DAQCard-1200 can monitor four different analog input signals.

Considerations for using DIFF input mode are discussed in Chapter 3, *Connecting the Signals*. Notice that the signal return path is through the negative terminal of the instrumentation amplifier and through channel 1, 3, 5, or 7 depending on which channel pair you select.

### RSE Input Mode (Eight Channels, Default Setting)

RSE input mode means that all input signals are referenced to a common ground point that is also tied to the DAQCard-1200 AI ground. The RSE mode is useful for measuring floating signal sources. Refer to the *Types of Signal Sources* section of Chapter 3, *Connecting the Signals*, for more information. With the RSE configuration, the DAQCard-1200 can monitor eight different analog input channels.

Considerations for using the RSE mode are discussed in Chapter 3, *Connecting the Signals*. Notice that in RSE mode, the return path of the signal is through analog ground at the connector through the AISENSE/AIGND pin.

### NRSE Input Mode (Eight Channels)

NRSE input mode means that all signals are referenced to the same common-mode voltage, which is allowed to float with respect to the analog ground of the DAQCard-1200. This common mode voltage is subsequently subtracted out by the instrumentation amplifier. NRSE input mode is useful when measuring ground-referenced signal sources.

Considerations for using the NRSE configuration are discussed in Chapter 3, *Connecting the Signals*. Notice that in this mode, the return path of the signal is through the negative terminal of the amplifier, available at the connector through the pin AISENSE/AIGND.

## Configuring Analog Output

You can set the analog output on the DAQCard-1200 to either bipolar or unipolar configurations.

Parameter	Configuration
Analog Output CH0 Polarity	Bipolar— $\pm 5$ V (default setting) Unipolar—0–10 V
Analog Output CH1 Polarity	Bipolar— $\pm 5$ V (default setting) Unipolar—0–10 V

## Analog Output Polarity

The DAQCard-1200 has two channels of AO voltage at the front panel I/O connector. You can configure each AO channel for either unipolar or bipolar output. A unipolar configuration has a range of 0 to 10 V at the analog output. A bipolar configuration has a range of -5 to +5 V at the analog output. If you select a bipolar range for a D/A conversion, the two's complement coding mode is selected. In this mode, data values written to the AO channel range from F800 hex (-2,048 decimal) to 7FF hex (2,047 decimal). If you select a unipolar range, you are selecting the straight binary coding. In this mode, data values written to the AO channel range from 0 to FFF hex (4,095 decimal).

## Configuring Digital I/O

The DAQCard-1200 uses the MSM82C55 programmable peripheral interface (PPI). This chip provides 24 digital lines in the form of three ports—A, B, and C. On power up, all three ports reset to high-impedance inputs. For information about configuring the MSM82C55, Refer to the *Analog Input Timing Connections* section of Chapter 3, *Connecting the Signals*.



**Caution** The DAQCard-1200 DIO lines are not pulled up or pulled down. If you are using these lines as digital outputs, add 10 k $\Omega$  resistors to +5 V or DGND (depending on your application) to the DIO line(s) you are using.

## Configuring Counters

You can use the MSM82C53A counter/timers for general-purpose timing applications, such as pulse and square wave generation, event counting, and pulse-width, time-lapse, and frequency measurements. For information about configuring the MSM82C53A, refer to the *Analog Input Timing Connections* section of Chapter 3, *Connecting the Signals*.



---

# Connecting the Signals

This chapter describes the signals on the DAQCard-1200 I/O connector.

## I/O Connector

---

Figure 3-1 shows the pin assignments for the DAQCard-1200 I/O connector. This connector is attached to the ribbon cable that extends from the PC Card slot when the card is installed and the cable is connected.



**Caution** Connections, including power signals to ground and vice versa, that exceed any of the maximum ratings of input or output signals on the DAQCard-1200 can damage the DAQCard-1200 and the computer. NI is *not* liable for damage resulting from any such signal connections.

ACH0	1	2	ACH1
ACH2	3	4	ACH3
ACH4	5	6	ACH5
ACH6	7	8	ACH7
AISENSE/AIGND	9	10	DAC0OUT
AGND	11	12	DAC1OUT
DGND	13	14	PA0
PA1	15	16	PA2
PA3	17	18	PA4
PA5	19	20	PA6
PA7	21	22	PB0
PB1	23	24	PB2
PB3	25	26	PB4
PB5	27	28	PB6
PB7	29	30	PC0
PC1	31	32	PC2
PC3	33	34	PC4
PC5	35	36	PC6
PC7	37	38	EXTTRIG
EXTUPDATE*	39	40	EXTCONV*
OUTB0	41	42	GATB0
OUTB1	43	44	GATB1
CLKB1	45	46	OUTB2
GATB2	47	48	CLKB2
+5 V	49	50	DGND

**Figure 3-1.** DAQCard-1200 I/O Connector Pin Assignments

# Signal Connection Descriptions

Table 3-1 describes the connector pins on the DAQCard-1200 front I/O connector by pin number and gives the signal name and information about each signal connector pin.

**Table 3-1.** Signal Descriptions

Pins	Signal Name	Direction	Reference	Description
1–8	ACH<0..7>	AI	AGND	Analog Channel 0 through 7—Analog input channels 0 through 7.
9	AISENSE/AIGND	AI	AGND	Analog Input Sense/Analog Input Ground—Connected to AGND in RSE mode, analog input sense in NRSE mode.
10	DAC0OUT	AO	AGND	DAC0 Output—Voltage output signal for analog output channel 0.
11	AGND	N/A	N/A	Analog Ground—Analog output ground reference for analog output voltages. This signal is the bias current return point for differential measurements.
12	DAC1OUT	AO	AGND	DAC1 Output—Voltage output signal for analog output channel 1.
13	DGND	N/A	N/A	Digital Ground—Voltage ground reference for the digital signals and the +5 V supply.
14–21	PA<0..7>	DIO	DGND	Port A 0 through 7—Bidirectional data lines for port A. PA7 is the MSB, and PA0 is the LSB.
22–29	PB<0..7>	DIO	DGND	Port B 0 through 7—Bidirectional data lines for port B. PB7 is the MSB, and PB0 is the LSB.
30–37	PC<0..7>	DIO	DGND	Port C 0 through 7—Bidirectional data lines for port C. PC7 is the MSB, and PC0 is the LSB.
38	EXTTRIG	DI	DGND	External Trigger—External control signal to trigger a DAQ operation.
39	EXTUPDATE*	DI	DGND	External Update—External control signal to update DAC outputs.
40	EXTCONV*	DIO	DGND	External Convert—External control signal to time A/D conversions (DI) and drive SCANCLK when you use SCXI (DO).
41	OUTB0	DO	DGND	Output B0—Voltage output signal of counter B0.
42	GATB0	DI	DGND	Gate B0—External control signal for gating counter B0.
43	OUTB1	DIO	DGND	Output B1—Voltage output signal of counter B1 when selected as output (DO). This is the external control signal for timing an interval cycle when selected as input (DI).

**Table 3-1.** Signal Descriptions (Continued)

Pins	Signal Name	Direction	Reference	Description
44	GATB1	DI	DGND	Gate B1—External control signal for gating counter B1.
45	CLKB1	DI	DGND	Clock B1—External control clock signal for counter B1.
46	OUTB2	DO	DGND	Counter B2—Voltage output signal of counter B2.
47	GATB2	DI	DGND	Gate B2—External control signal for gating counter B2.
48	CLKB2	DI	DGND	Clock B2—External control clock signal for counter B2.
49	+5 V	DO	DGND	+5 Volts—Fused for up to 1 A of +5 V supply, but limit current to 250 mA.
50	DGND	N/A	N/A	Digital Ground—Voltage ground reference for the digital signals and the +5 V supply.
<p>* Indicates that the signal is active low.            AI = Analog Input    DI = Digital Input    DIO = Digital Input/Output            AO = Analog Output    DO = Digital Output    N/A = Not Applicable</p>				

The connector pins are grouped into AI signal pins, AO signal pins, DIO signal pins, TIO signal pins, and power connections. Signal connection guidelines for each group is described in the following sections.

## Connecting Analog Input Signals

Pins 1 through 8 are analog input signal pins for the 12-bit ADC. Pin 9, AISENSE/AIGND, is an analog common signal. You can use this pin as a signal ground connection to the DAQCard-1200 in RSE mode or as a return path in NRSE mode. Pin 11, AGND, is the bias current return point for differential measurements. Pins 1 through 8 are tied, through 4.7 k $\Omega$  series resistances, to the eight single-ended AI channels of the input multiplexer. Pins 2, 4, 6, and 8 are also tied to an input multiplexer for DIFF mode.

The signal ranges for inputs ACH<0..7> at all possible gains are shown in Table 3-2. Exceeding the input signal range does not damage the input circuitry as long as the maximum input voltage rating of  $\pm 35$  V powered on and  $\pm 25$  V powered off is not exceeded. The DAQCard-1200 is guaranteed to withstand inputs up to the maximum input voltage rating.



**Caution** Exceeding the input signal range distorts input signals. Exceeding the maximum input voltage rating may damage the DAQCard-1200 and the computer. NI is *not* liable for damage resulting from such signal connections.

**Table 3-2.** Bipolar and Unipolar Analog Input Signal Range Versus Gain

Gain Setting	Input Signal Range	
	Bipolar	Unipolar
1	±5 V	0 to 10 V
2	±2.5 V	0 to 5 V
5	±1 V	0 to 2 V
10	±500 mV	0 to 1 V
20	±250 mV	0 to 500 mV
50	±100 mV	0 to 200 mV
100	±50 mV	0 to 100 mV

How you connect analog input signals to the DAQCard-1200 depends on how you configure the card analog input circuitry and the type of input signal source. With different DAQCard-1200 input modes, you can use the instrumentation amplifier in different ways. Figure 3-2 shows a diagram of the DAQCard-1200 instrumentation amplifier.

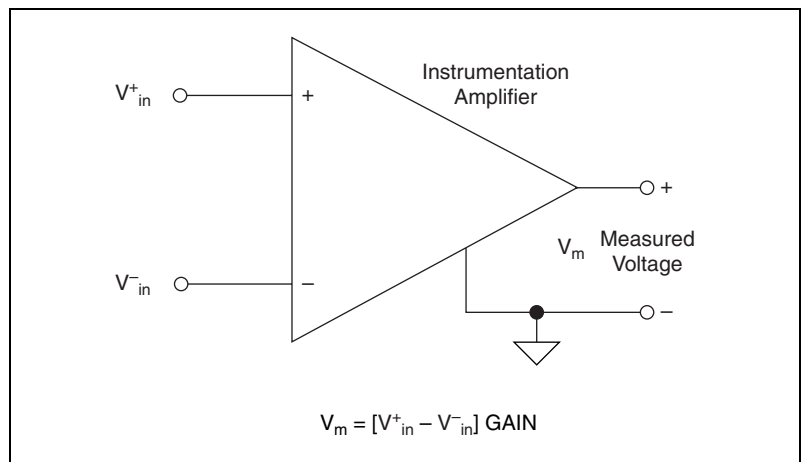
**Figure 3-2.** DAQCard-1200 Instrumentation Amplifier

The instrumentation amplifier applies gain, common-mode voltage rejection, and high-input impedance to the AI signals connected to the DAQCard-1200. Signals are routed to the positive and negative inputs of the instrumentation amplifier through input multiplexers on the DAQCard-1200. The instrumentation amplifier converts two input signals to a signal that is the difference between the two input signals multiplied by the gain setting of the amplifier. The amplifier output voltage is referenced to the DAQCard-1200 ground. The DAQCard-1200 ADC measures this output voltage when it performs A/D conversions.

All signals must be referenced to ground, either at the source device or at the DAQCard-1200. If you have a floating source, you must use a ground-referenced input connection at the DAQCard-1200. If you have a grounded source, you must use a nonreferenced input connection at the DAQCard-1200.

## Types of Signal Sources

When configuring the input mode of the DAQCard-1200 and making signal connections, you must first determine whether the signal source is floating or ground referenced. This section describes these two types of signals.

### Floating Signal Sources

A floating signal source is not connected in any way to the building ground system but has an isolated ground-reference point. Some examples of floating signal sources are outputs of transformers, thermocouples, battery-powered devices, optical isolator outputs, and isolation amplifiers. You must tie the ground reference of a floating signal to the DAQCard-1200 AI ground to establish a local or onboard reference for the signal. Otherwise, the measured input signal varies or appears to float. An instrument or device that supplies an isolated output falls into the floating signal source category.

### Ground-Referenced Signal Sources

A ground-referenced signal source is connected in some way to the building system ground and is therefore already connected to a common ground point with respect to the DAQCard-1200, assuming that the computer is plugged into the same power system. Nonisolated outputs of instruments and devices that plug into the building power system fall into this category.

The difference in ground potential between two instruments connected to the same building power system is typically between 1 mV and 100 mV but can be much higher if power distribution circuits are improperly connected. The connection instructions that follow for grounded signal sources eliminate this ground potential difference from the measured signal.



**Note** If you power both the DAQCard-1200 and the PC with a floating power source, such as a battery, the system may be floating with respect to earth ground. In this case, treat all the signal sources as floating sources.

## Input Configurations

You can configure the DAQCard-1200 for one of three input modes—RSE, NRSE, or DIFF. The following sections discuss the use of single-ended and differential measurements and give considerations for measuring both floating and ground-referenced signal sources. Table 3-3 summarizes the recommended input modes for both types of signal sources.

**Table 3-3.** Recommended Input Modes for Ground-Referenced and Floating Signal Sources

Type of Signal	Recommended Input Configuration
Ground-Referenced (nonisolated outputs, plug-in instruments)	DIFF NRSE
Floating (batteries, thermocouples, isolated outputs)	DIFF with bias resistors RSE

## Differential Connection Considerations (DIFF Input Mode)

Differential connections are those in which each DAQCard-1200 AI signal has its own reference signal or signal return path. These connections are available when you configure the DAQCard-1200 in the DIFF input mode. Each input signal is tied to the positive input of the instrumentation amplifier, and its reference signal, or return, is tied to the negative input of the instrumentation amplifier.

You should use the DIFF input configuration when any of the following conditions are present:

- Input signals are low level (less than 1 V).
- Leads connecting signals to the DAQCard-1200 are greater than 15 ft.
- Any input signal requires a separate ground-reference point or return signal.
- The signal leads travel through noisy environments.

Differential signal connections reduce noise pickup noise and increase common-mode noise rejection. With these connections, input signals can float within the common-mode limits of the input instrumentation amplifier.

### **Differential Connections for Floating Signal Sources**

Figure 3-3 shows how to connect a floating signal source to a DAQCard-1200 that is configured for DIFF input mode. Configuration instructions are included in the [Configuring Analog Input](#) section of Chapter 2, [Installing and Configuring the DAQCard-1200](#).



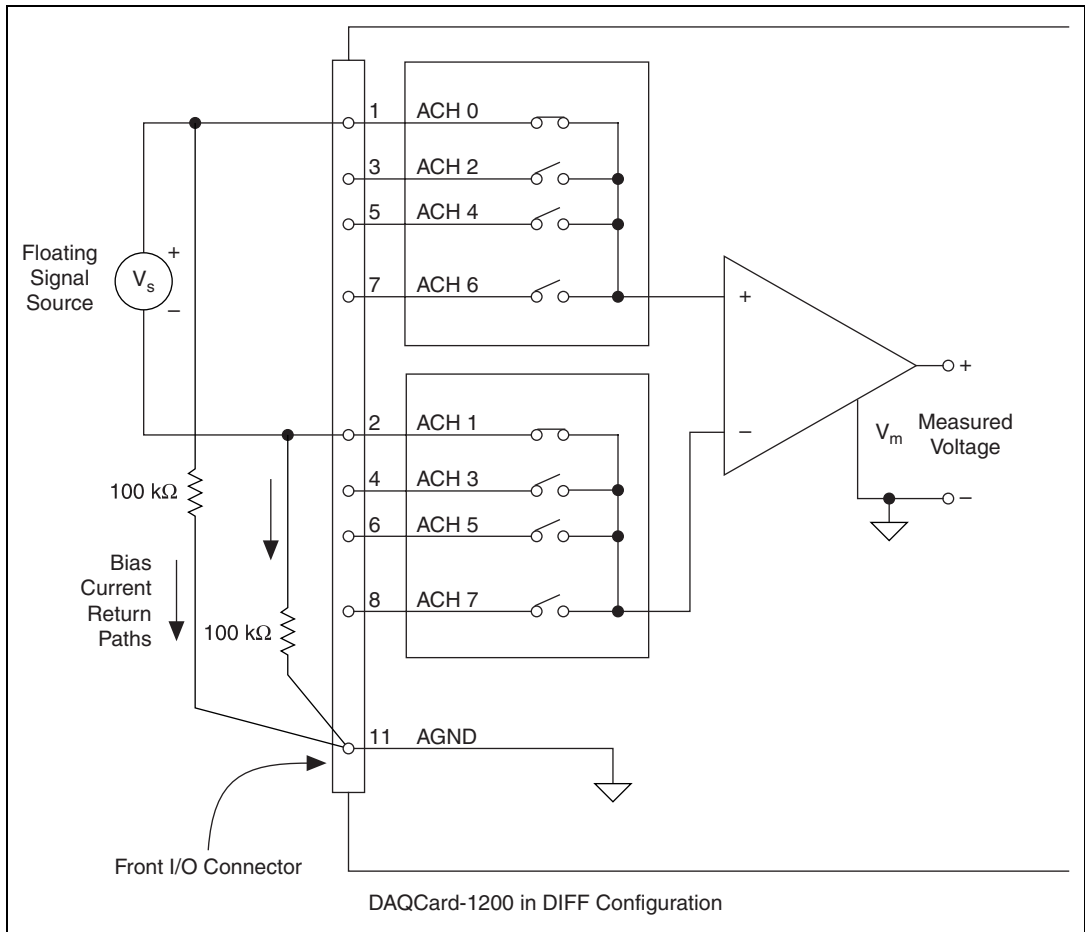

**Figure 3-3.** Differential Input Connections for Floating Sources

The  $100\text{ k}\Omega$  resistors shown in Figure 3-3 create a return path to ground for the bias currents of the instrumentation amplifier. If there is no return path, the instrumentation amplifier bias currents cause stray capacitances, resulting in uncontrollable drift and possible saturation in the amplifier.

A resistor from each input to ground, as shown in Figure 3-3, provides bias current return paths for an AC-coupled input signal.

If the input signal is DC-coupled, you need only the resistor that connects the negative signal input to ground. This connection does not lower the input impedance of the AI channel.

### Differential Connections for Grounded Signal Sources

Figure 3-4 shows how to connect a ground-referenced signal source to a DAQCard-1200 configured for DIFF input mode. Refer to the [Configuring Analog Input](#) section of Chapter 2, [Installing and Configuring the DAQCard-1200](#), for configuration instructions.

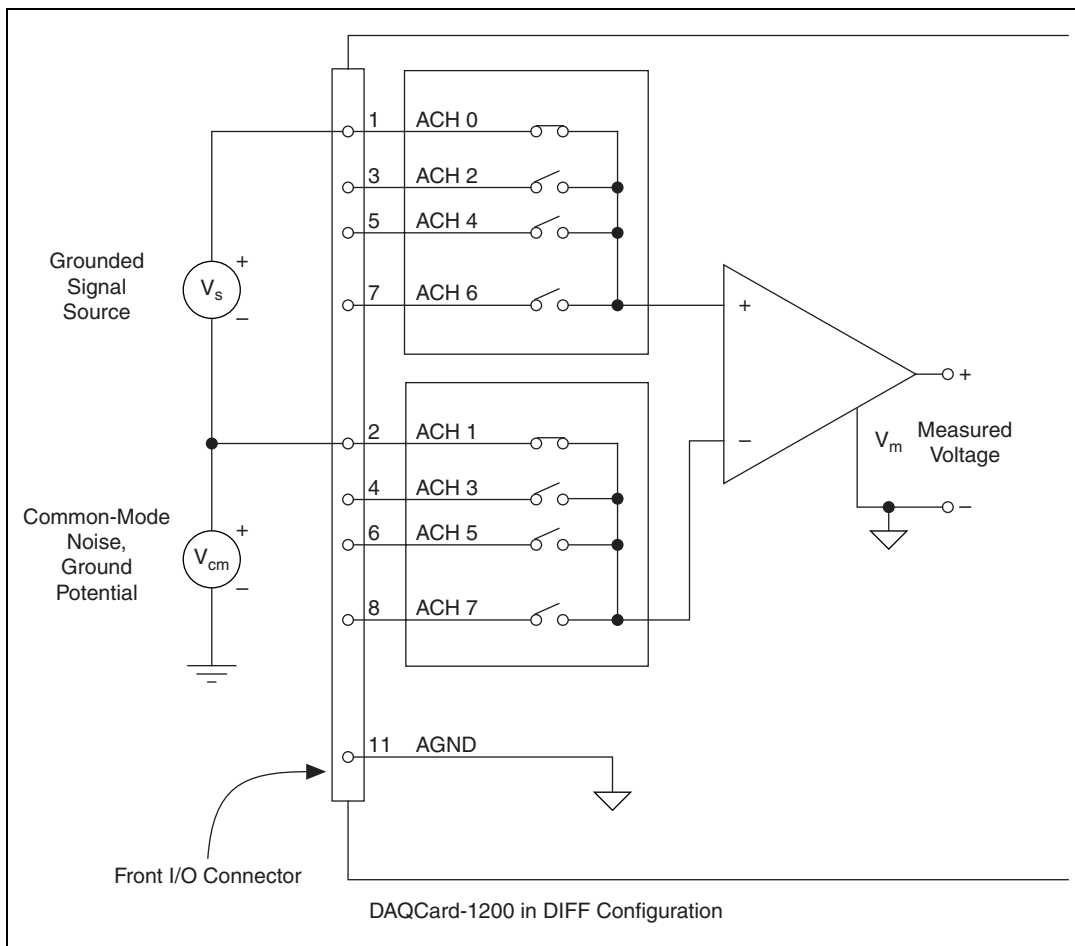

**Figure 3-4.** Differential Input Connections for Grounded Signal Sources

With this connection type, the instrumentation amplifier rejects both the common-mode noise in the signal and the ground-potential difference between the signal source and the DAQCard-1200 ground, which is shown as  $V_{cm}$  in Figure 3-4.

## Single-Ended Connection Considerations (RSE and NRSE Input Modes)

Single-ended connections are those in which all DAQCard-1200 AI signals are referenced to one common ground. The input signals are tied to the positive input of the instrumentation amplifier, and their common ground point is tied to the negative input of the instrumentation amplifier.

When the DAQCard-1200 is configured for single-ended input (RSE or NRSE), eight AI channels are available. You can use single-ended input connections when the following criteria are met by all input signals:

- Input signals are high level (greater than 1 V).
- Leads connecting the signals to the DAQCard-1200 are less than 15 ft.
- All input signals share a common reference signal (at the source).

If any of the preceding criteria are not met, you should use DIFF input mode.

You can configure the DAQCard-1200 using software for two different types of single-ended input modes, RSE and NRSE. Use RSE input mode for floating signal sources; in this case, the DAQCard-1200 provides the reference ground point for the external signal. Use NRSE input mode for ground-referenced signal sources; in this case, the external signal supplies its own reference ground point and the DAQCard-1200 should not supply one.

### Single-Ended Connections for Floating Signal Sources (RSE Input Mode)

Figure 3-5 shows how to connect a floating signal source to a DAQCard-1200 configured for single-ended input. You must configure the DAQCard-1200 analog input circuitry for RSE input mode to make these connections. For configuration instructions, refer to the [Configuring Analog Input](#) section of Chapter 2, [Installing and Configuring the DAQCard-1200](#).

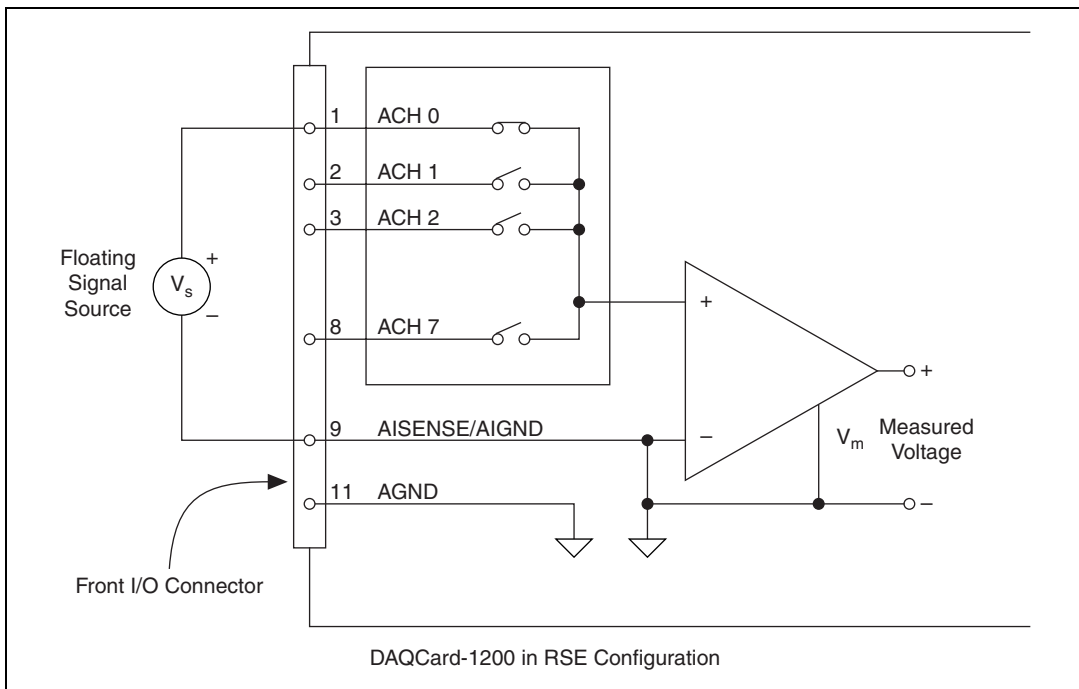
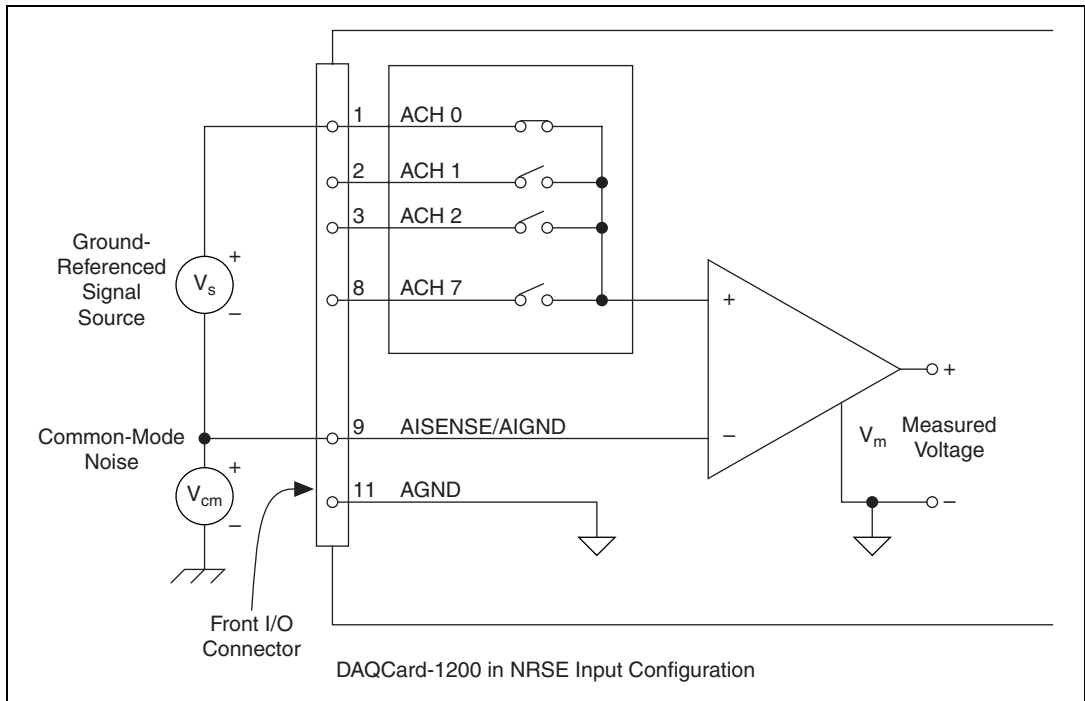

**Figure 3-5.** Single-Ended Input Connections for Floating Signal Sources

### Single-Ended Connections for Grounded Signal Sources (NRSE Input Mode)

If you measure a grounded signal source with a single-ended configuration, you must configure the DAQCard-1200 in the NRSE input configuration. The signal is connected to the positive input of the DAQCard-1200 instrumentation amplifier, and the signal local ground reference is connected to the negative input of the DAQCard-1200 instrumentation amplifier. Therefore, you must connect the ground point of the signal to the AISENSE/AIGND pin. Any potential difference between the DAQCard-1200 ground and the signal ground appears as a common-mode signal at both the positive and negative inputs of the instrumentation amplifier and is therefore rejected by the amplifier. NRSE input mode must be used in place of the RSE input mode to prevent any difference in ground potentials from appearing as an error in the measured voltage.

Figure 3-6 shows how to connect a grounded signal source to a DAQCard-1200 configured in the NRSE configuration. For configuration instructions, refer to the [Configuring Analog Input](#) section of Chapter 2, [Installing and Configuring the DAQCard-1200](#).



**Figure 3-6.** Single-Ended Input Connections for Grounded Signal Sources

### Common-Mode Signal Rejection Considerations

Figures 3-4 and 3-6 show connections for signal sources that are already referenced to some ground point with respect to the DAQCard-1200. In these cases, the instrumentation amplifier can reject any voltage caused by ground-potential differences between the signal source and the DAQCard-1200. In addition, with differential input mode connections, the instrumentation amplifier can reject common-mode noise pickup in the leads connecting the signal sources to the DAQCard-1200.

The common-mode input range of the DAQCard-1200 instrumentation amplifier is the magnitude of the greatest common-mode signal that can be rejected.

The common-mode input range for the DAQCard-1200 depends on the size of the differential input signal ( $V_{diff} = V_{in+} - V_{in-}$ ) and the gain setting of the instrumentation amplifier. In unipolar mode, the differential input range is 0 to 10 V. In bipolar mode, the differential input range is from -5 to +5 V.  $V_{in-}$  should remain within a range of -6 to +6 V in bipolar mode and

–6 to +2 V in unipolar mode.  $V_{in+}$  should remain within a range of –6 to +11 V in either mode.

## Connecting Analog Output Signals

Pins 10 through 12 of the front connector are the AO signals DAC0OUT, AGND, and DAC1OUT.

DAC0OUT is the voltage output signal for AO channel 0. DAC1OUT is the voltage output signal for AO channel 1. AGND is the ground-reference point for both AO channels and analog input.

The following output ranges are available, and for each output range, the maximum load current is  $\pm 1$  mA for 12-bit linearity (per DAC):

- Output signal range
  - Bipolar output  $\pm 5$  V
  - Unipolar output 0 to 10 V

Figure 3-7 shows how to make AO signal connections.

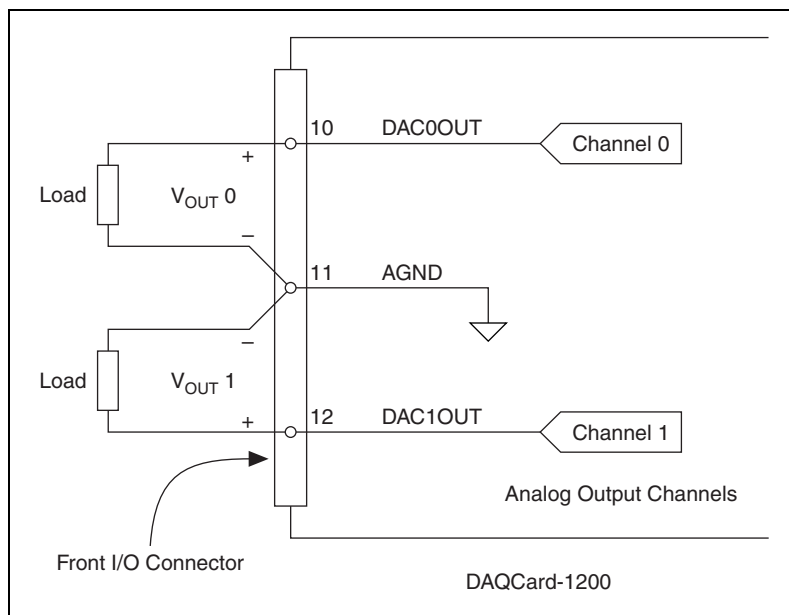

**Figure 3-7.** Analog Output Signal Connections

## Connecting Digital I/O Signals



**Caution** The DAQCard-1200 DIO lines are not pulled up or pulled down. If you are using these lines as digital outputs, add 10 k $\Omega$  resistors to +5 V or DGND (depending on your application) to the DIO line(s) you are using.

Pins 13 through 37 of the front connector are DIO signal pins. DIO on the DAQCard-1200 uses the 82C55A integrated circuit. The 82C55A is a general-purpose peripheral interface containing 24 programmable I/O pins. These pins represent the three 8-bit ports (PA, PB, and PC) of the 82C55A.

Pins 14 through 21 are connected to the digital lines PA<0..7> for DIO port A. Pins 22 through 29 are connected to the digital lines PB<0..7> for DIO port B. Pins 30 through 37 are connected to the digital lines PC<0..7> for DIO port C. Pin 13, DGND, is the digital ground pin for all three DIO ports. Refer to Appendix A, *Specifications*, for signal voltage and current specifications.

Figure 3-8 illustrates signal connections for three typical DIO applications.

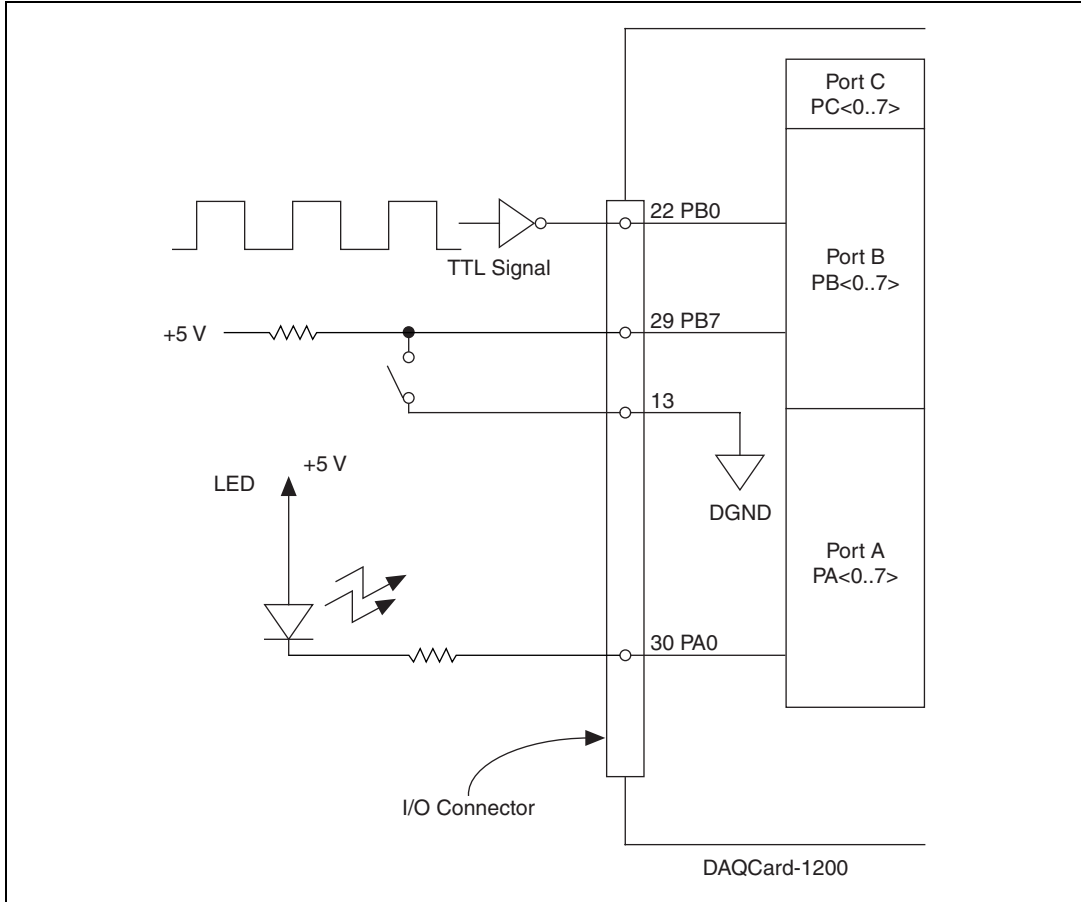

**Figure 3-8.** Digital I/O Connections

In Figure 3-8, port A is configured for digital output, and ports B and C are configured for digital input. Digital input applications include receiving TTL signals and sensing external device states such as the switch in Figure 3-8. Digital output applications include sending TTL signals and driving external devices, such as the LED shown in Figure 3-8.



**Note** The 82C55A has only one configuration register. Therefore, you must program the direction (input/output) of all ports before writing or reading from them to prevent data loss caused by the ports being reset to their default state.



## Port C Pin Connections

The signals assigned to port C depend on how the 82C55A is configured. In mode 0, or no-handshaking configuration, port C is configured as two 4-bit I/O ports. In modes 1 or 2, or handshaking configuration, port C is used for status and handshaking signals with zero, two, or three lines available for general-purpose I/O. Table 3-4 summarizes the port C signal assignments for each configuration.



**Note** Table 3-4 shows both the port C signal assignments and the terminology correlation between different documentation sources. The 82C55A terminology refers to the different 82C55A configurations as modes, whereas NI-DAQ and LabVIEW documentation refers to them as handshaking and no handshaking. These signal assignments are the same for all four 82C55A PPIs.

**Table 3-4.** Port C Signal Assignments

Configuration Terminology		Signal Assignments							
82C55A/ DAQCard-1200 User Manual	NI-DAQ/ LabVIEW	PC7	PC6	PC5	PC4	PC3	PC2	PC1	PC0
Mode 0 (Basic I/O)	No Handshaking	I/O	I/O	I/O	I/O	I/O	I/O	I/O	I/O
Mode 1 (Strobed Input)	Handshaking	I/O	I/O	IBF <sub>A</sub>	STB <sub>A</sub> *	INTR <sub>A</sub>	STB <sub>B</sub> *	IBFB <sub>B</sub>	INTR <sub>B</sub>
Mode 1 (Strobed Output)	Handshaking	OBF <sub>A</sub> *	ACK <sub>A</sub> *	I/O	I/O	INTR <sub>A</sub>	ACK <sub>B</sub> *	OBF <sub>B</sub> *	INTR <sub>B</sub>
Mode 2 (Bidirectional Bus)	Handshaking	OBF <sub>A</sub> *	ACK <sub>A</sub> *	IBF <sub>A</sub>	STB <sub>A</sub> *	INTR <sub>A</sub>	I/O	I/O	I/O
* Indicates that the signal is active low. Subscripts A and B denote port A or port B handshaking signals.									

## Timing Specifications

Use the handshaking lines STB\* and IBF to synchronize input transfers. Use the handshaking lines OBF\* and ACK\* to synchronize output transfers.

The following signals are used in the timing diagrams shown later in this chapter:

Name	Type	Description
STB*	Input	Strobe Input—A low signal on this handshaking line loads data into the input latch.
IBF	Output	Input Buffer Full—A high signal on this handshaking line indicates that data has been loaded into the input latch. This is primarily an input acknowledge signal.
ACK*	Input	Acknowledge Input—A low signal on this handshaking line indicates that the data written from the specified port has been accepted. This signal is primarily a response from the external device that it has received the data from the DAQCard-1200.
OBF*	Output	Output Buffer Full—A low signal on this handshaking line indicates that data has been written from the specified port.
INTR	Output	Interrupt Request—This signal becomes high when the 82C55A requests service during a data transfer. Set the appropriate interrupt enable signals to generate this signal.
RD*	Internal	Read—This signal is the read signal generated from the parallel port interface circuitry.
WRT*	Internal	Write—This signal is the write signal generated from the parallel port interface circuitry.
DATA	Bidirectional	Data Lines at the Specified Port—This signal indicates when the data on the data lines at a specified port is or should be available.

## Mode 1 Input Timing

Figure 3-9 shows the timing specifications for an input transfer in mode 1.

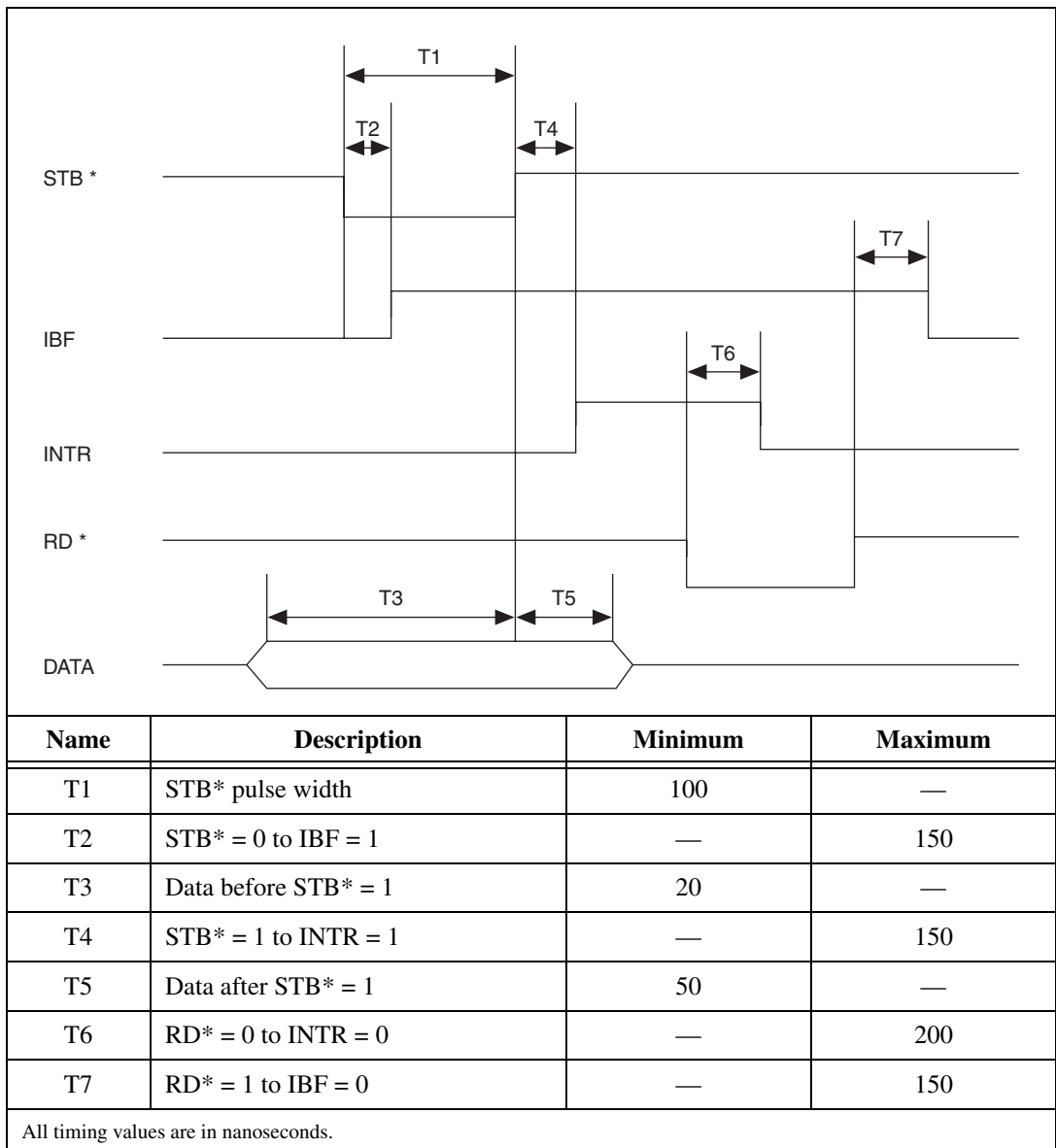

**Figure 3-9.** Mode 1 Timing Specifications for Input Transfers

### Mode 1 Output Timing

Figure 3-10 shows the timing specifications for an output transfer in mode 1.

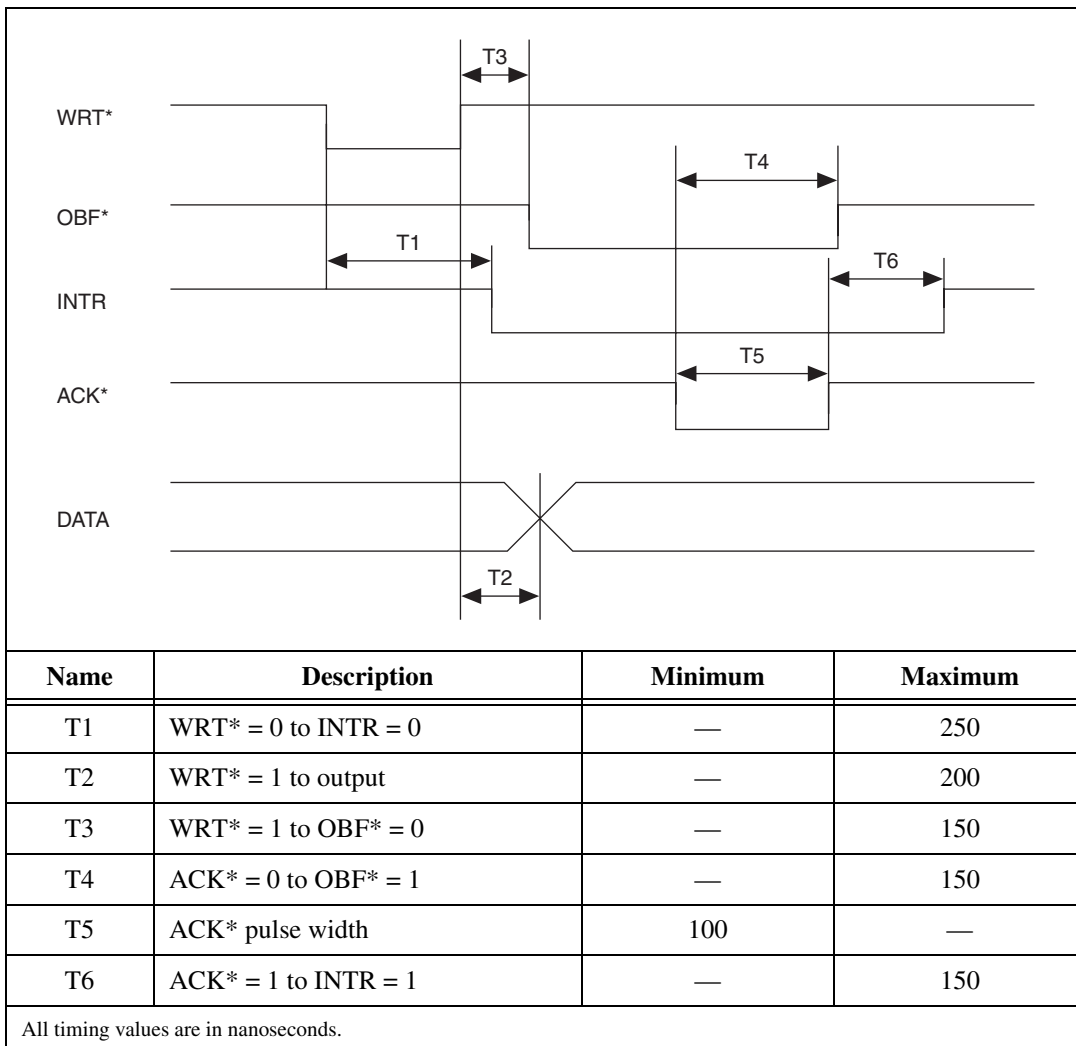

Figure 3-10. Mode 1 Timing Specifications for Output Transfers

### Mode 2 Bidirectional Timing

Figure 3-11 shows the timing specifications for bidirectional transfers in mode 2.

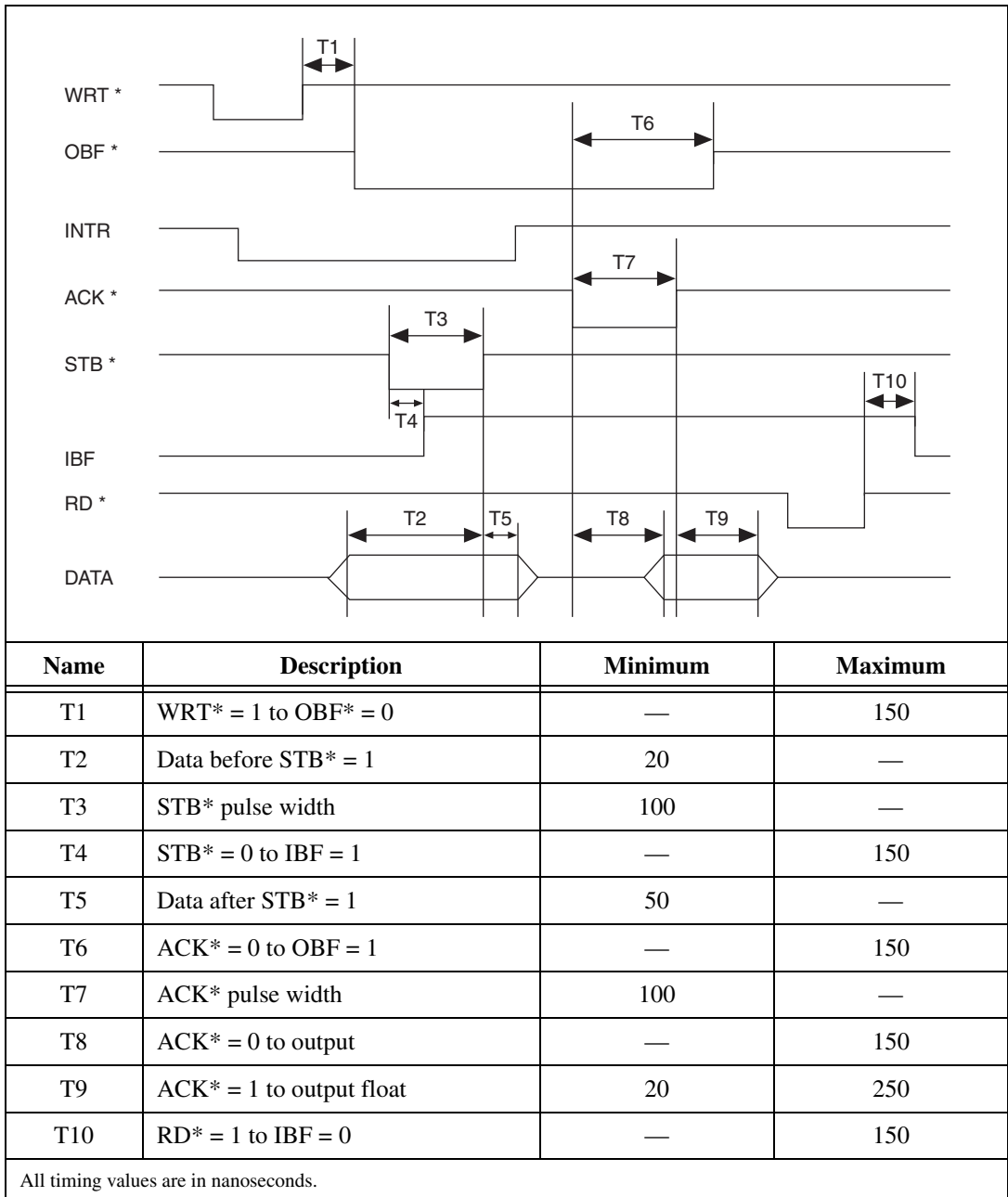

Figure 3-11. Mode 2 Timing Specifications for Bidirectional Transfers

## Connecting Analog I/O and General-Purpose Timing Signals

Pins 38 through 48 of the front connector are connections for timing I/O signals. The DAQCard-1200 timing I/O uses two 82C53 counter/timer integrated circuits. One circuit, designated 82C53(A), is used exclusively for DAQ timing, and the other, 82C53(B), is available for general use. You can use pins 38 through 40 and pin 43 to carry external signals for DAQ timing in place of the dedicated 82C53(A). These signals are explained in the next section, *Analog Input Timing Connections*. Pins 41 through 48 carry general-purpose timing signals from 82C53(B). These signals are explained in the *General-Purpose Timing Connections* section.

### Analog Input Timing Connections

Each 82C53 counter/timer circuit contains three counters. Counter 0 on the 82C53(A) counter/timer, referred to as A0, is a sample-interval counter in timed A/D conversions. The sample interval counter, or channel clock, controls the time between A/D conversions. A sample interval is also referred to as the interchannel delay. Counter 1 on the 82C53(A) counter/timer, referred to as A1, is a sample counter in timed A/D conversions. Therefore, counter A1 stops data acquisition after a predefined number of samples. These counters are not available for general-purpose use.

Counter B1 is a scan-interval counter in timed A/D conversions. The scan-interval counter, or scan clock, controls the time between when the first channel in the scan is sampled and when that channel is sampled again. When the scan-interval counter is used in conjunction with the sample interval counter, this is referred to as interval scanning. For a more complete description of interval and round-robin scanning, refer to Figure 3-12.

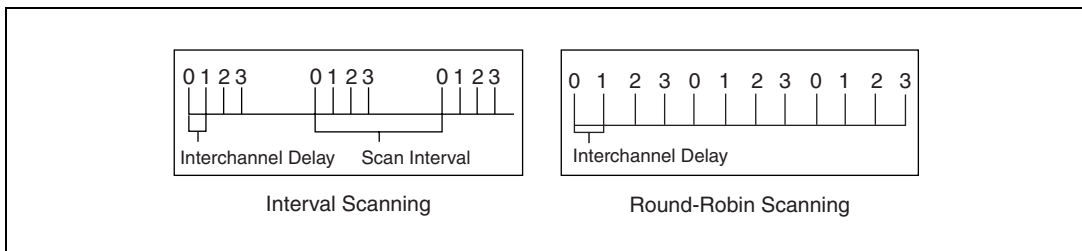

**Figure 3-12.** Interval Scanning and Round-Robin Scanning

Instead of using counter A0 as the sample-interval counter, you can use EXTCONV\* to externally time conversions. Figure 3-13 shows the timing requirements for the EXTCONV\* input. A falling edge on the EXTCONV\* initiates an A/D conversion.

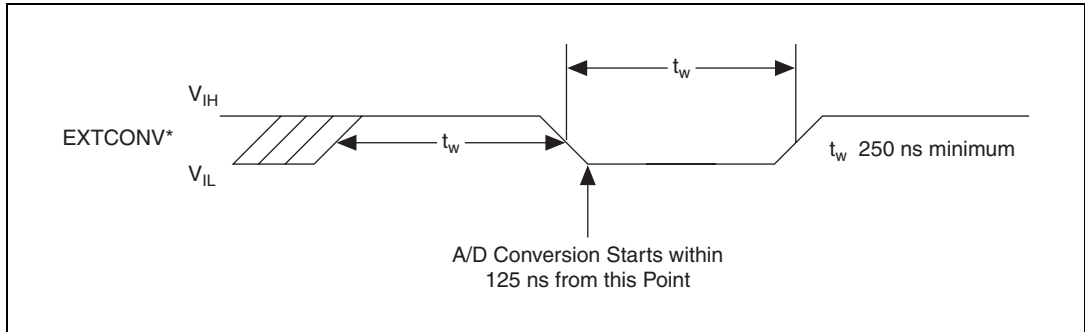

**Figure 3-13.** EXTCONV\* Signal Timing

The external control signal EXTTRIG can either start a DAQ sequence or terminate an ongoing DAQ sequence depending on the mode—posttrigger or pretrigger. These modes are software-selectable.



**Note** LabVIEW is scan clock oriented. When you specify the scan rate, you are controlling the scan interval timing.

In the posttrigger mode, EXTTRIG serves as an external trigger that initiates a DAQ sequence. When you use counter A0 to time sample intervals, a rising edge on EXTTRIG starts counter A0 and the DAQ sequence. When you use EXTCONV\* to time sample intervals, data acquisition is enabled on a rising edge of EXTTRIG followed by a rising edge on EXTCONV\*. The first conversion occurs on the next falling edge of EXTCONV\*. Further transitions on the EXTTRIG line have no effect until a new DAQ sequence is established.

Figure 3-14 shows a possible timed data acquisition sequence using EXTCONV\* and EXTTRIG. The rising edge of EXTCONV\* that enables external conversions must occur a minimum of 50 ns after the rising edge of EXTTRIG. The first conversion occurs on the next falling edge of EXTCONV\*.

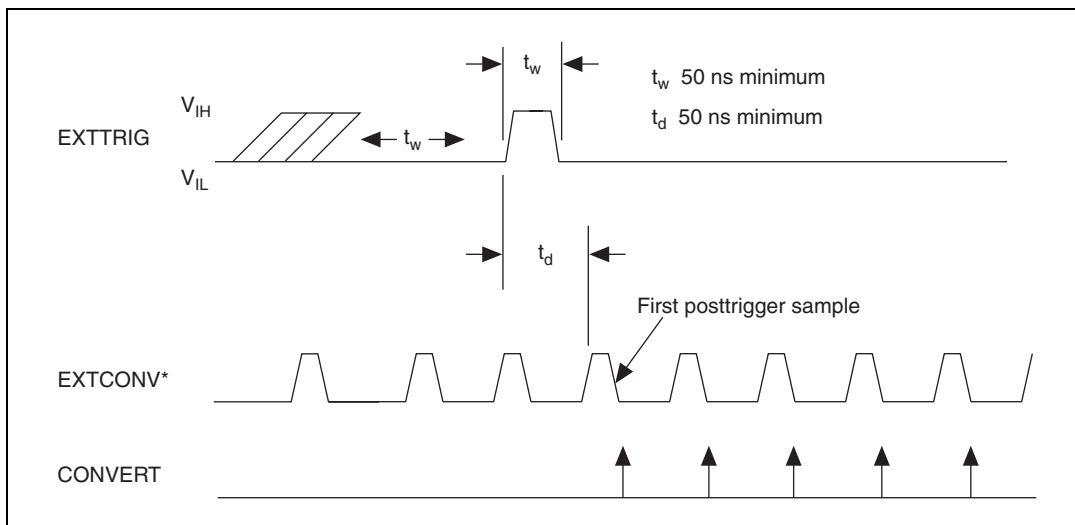
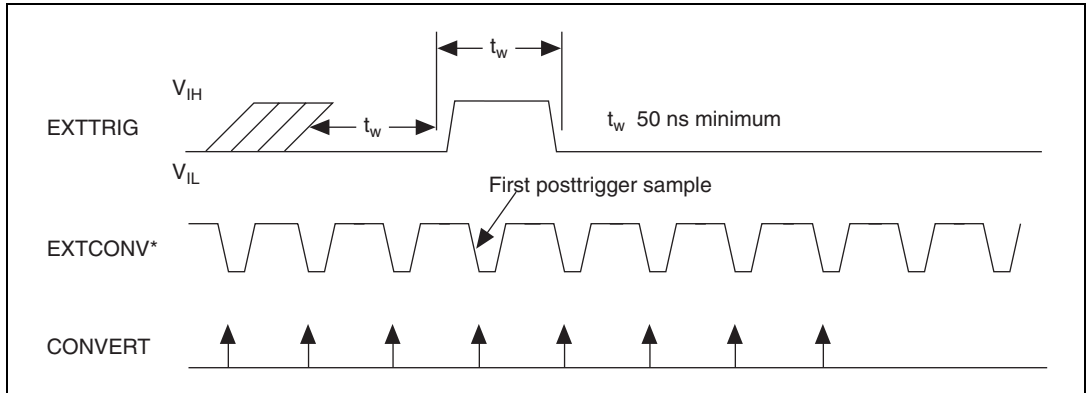

**Figure 3-14.** Posttrigger DAQ Timing

In the pretrigger mode, EXTTRIG serves as a stop-trigger signal. Data is acquired both before and after the stop trigger occurs. A/D conversions are software enabled, which initiates the DAQ operation. However, the sample counter is not started until a rising edge is sensed on the EXTTRIG input. Conversions remain enabled until the sample counter counts to zero. The maximum number of samples acquired after the stop trigger is limited to 65,535. The number of samples acquired before the trigger is limited only by the size of the memory buffer available for data acquisition.

Figure 3-15 shows a pretrigger DAQ timing sequence using EXTTRIG and EXTCONV\*. The DAQ operation has been initiated through software. Notice that the sample counter has been programmed to allow five conversions after the rising edge on the EXTTRIG signal. Additional transitions on the EXTTRIG line have no effect until you initiate a new DAQ sequence.



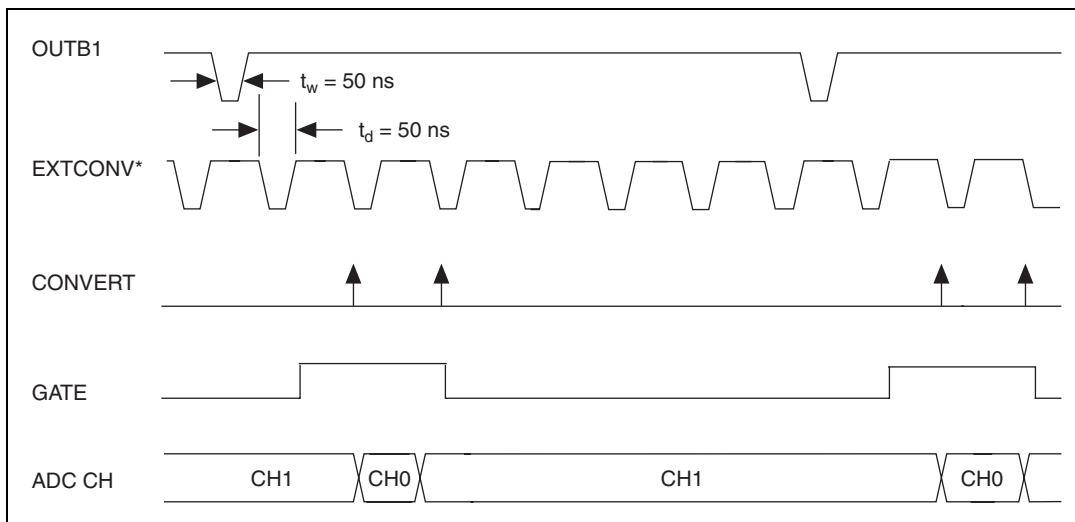

**Figure 3-15.** Pretrigger DAQ Timing

Because both pretrigger and posttrigger modes use EXTTRIG input, you can only use one mode at a time. Therefore, you cannot use *both* a hardware start and a hardware stop trigger during the same acquisition.

Figure 3-16 shows an example of a multiple-channel interval-scanning DAQ operation. The scan interval and the sample interval are being timed externally through OUTB1 and EXTCONV\*. Channels 1 and 0 of the input multiplexers are being scanned once during each scan interval. The first rising edge of EXTCONV\* must occur a minimum of 50 ns after the rising edge on OUTB1. The first rising edge of EXTCONV\* after the rising edge of OUTB1 enables an internal GATE signal that allows conversions to occur. The first conversion then occurs on the following falling edge of EXTCONV\*.

Instead of using counter B1, you can externally time the scan interval through OUTB1. If you externally time the sample interval, you should also externally time the scan interval.



**Figure 3-16.** Interval-Scanning Signal Timing

## Analog Output Timing Connections

Counter A2 is used to internally control updating the output voltage of the 12-bit DACs. In place of counter A2, you can use the final external control signal, EXTUPDATE\*, to externally control updating the output voltage of the 12-bit DACs and/or to generate an externally timed interrupt. There are two update modes—immediate update and delayed update. In immediate update mode the analog output is updated as soon as a value is written to the DAC. If you select the delayed update mode, a value is written to the DAC; however, the corresponding DAC voltage is not updated until a low level on the EXTUPDATE\* signal or counter A2 is sensed. Furthermore, an interrupt is generated whenever a rising edge is detected on the EXTUPDATE\* bit. The interrupt service routine can write the next value to the DAC. When the EXTUPDATE\* signal goes low, the DAC is subsequently updated. Therefore, you can perform externally timed interrupt-driven waveform generation on the DAQCard-1200.

Notice that the EXTUPDATE\* signal is level sensitive; that is, if you perform writes to the DAC when EXTUPDATE\* is low, the DAC is updated immediately. Also notice that when EXTUPDATE\* is low, the signal is susceptible to noise caused by switching of other lines. Because the signal is TTL-compatible, the lower noise margin for logical 0 can result in transitions to a logical 1 due to noise and thereby generate false interrupts. Therefore, the width of EXTUPDATE\* pulse should be as short as possible, but greater than 50 ns.

Figure 3-17 illustrates a waveform generation timing sequence using the EXTUPDATE\* signal and the delayed update mode. The DACs are updated by a high level on the DAC OUTPUT UPDATE signal, which in this case is triggered by a low level on the EXTUPDATE\* line. The counter-interrupt signal interrupts the computer. This interrupt is generated on the rising edge of EXTUPDATE\*. The DACWRT signal writes a new value to the DAC.

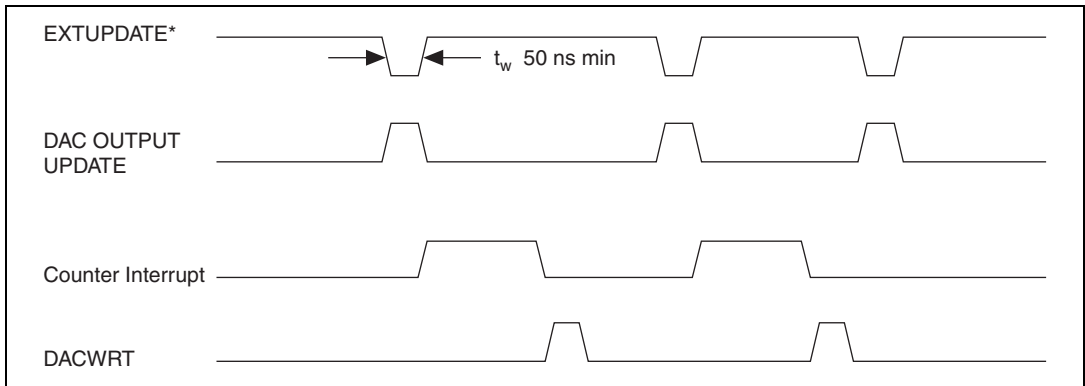

**Figure 3-17.** EXTUPDATE\* Signal Timing for Updating DAC Output



**Note** You should configure both DACs in either immediate update mode or in later update mode, but not in a combination of the two modes. Although you can configure the DACs in a combination of modes, doing so can result in glitches on the immediate update DAC if the update rate on the waveform DAC is high. Refer to the *Analog Output* section in Chapter 4, *Theory of Operation*, for details on this behavior.

The following rating applies to the EXTCONV\*, EXTTRIG, OUTB1, and EXTUPDATE\* signals.

- Absolute maximum voltage input rating –0.5 to 5.5 V with respect to DGND

Refer to the NI-DAQ manual or to Chapter 4, *Theory of Operation*, for more information concerning the various modes of data acquisition and analog output.

## General-Purpose Timing Connections

General-purpose timing signals include the GATE, CLK, and OUT signals for the three 82C53(B) counters. The 82C53 counter/timers can be used for many general-purpose applications such as pulse and square wave generation; event counting; and pulse-width, time-lapse, and frequency

measurement. For these applications, the CLK and GATE signals at the front I/O connector control the counters. The single exception is counter B0, which has an internal 2 MHz clock. Refer to the *DAQCard-1200 Register-Level Programmer Manual* for programming information.

The GATE, CLK, and OUT signals for counters B1 and B2 are available at the I/O front connector. The GATE and CLK pins are internally pulled up to +5 V through a 100 k $\Omega$  resistor. Refer to Appendix A, *Specifications*, for signal voltage and current specifications.

You perform pulse and square wave generation by programming a counter to generate a timing signal at its OUT output pin. Perform event counting by programming a counter to count rising or falling edges applied to any of the 82C53 CLK inputs. You can then read the counter value to determine the number of edges that have occurred. You can gate counter operations on and off during event counting. Figure 3-18 shows connections for a typical event-counting operation in which a switch is used to gate the counter on and off.

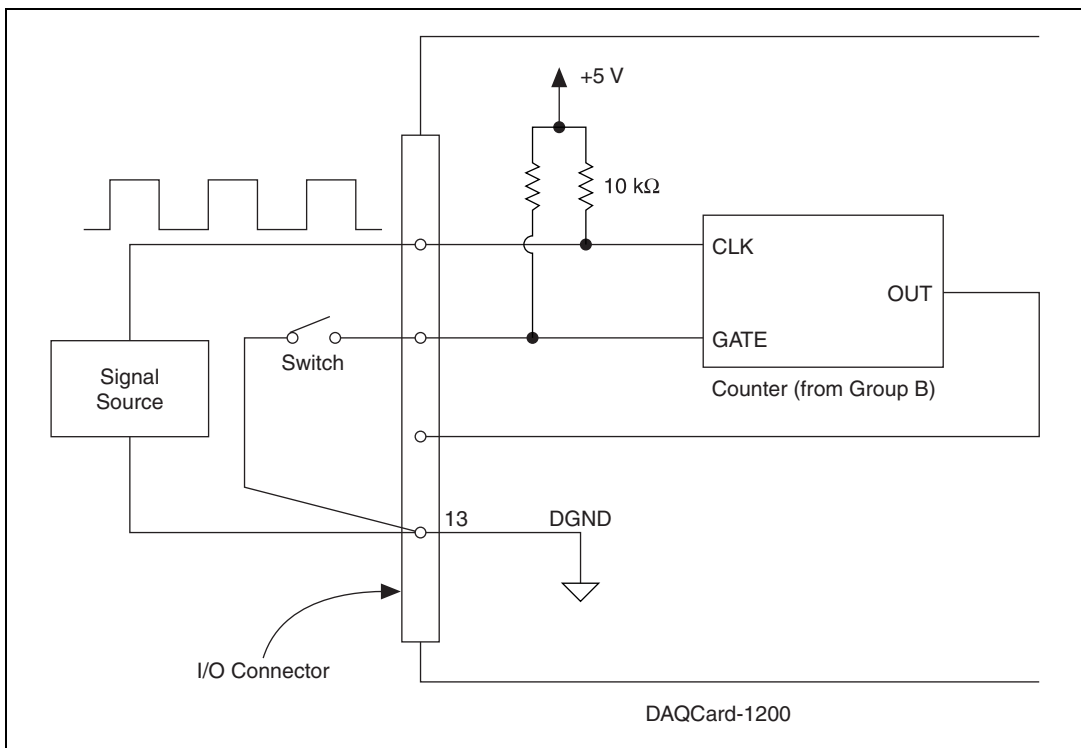
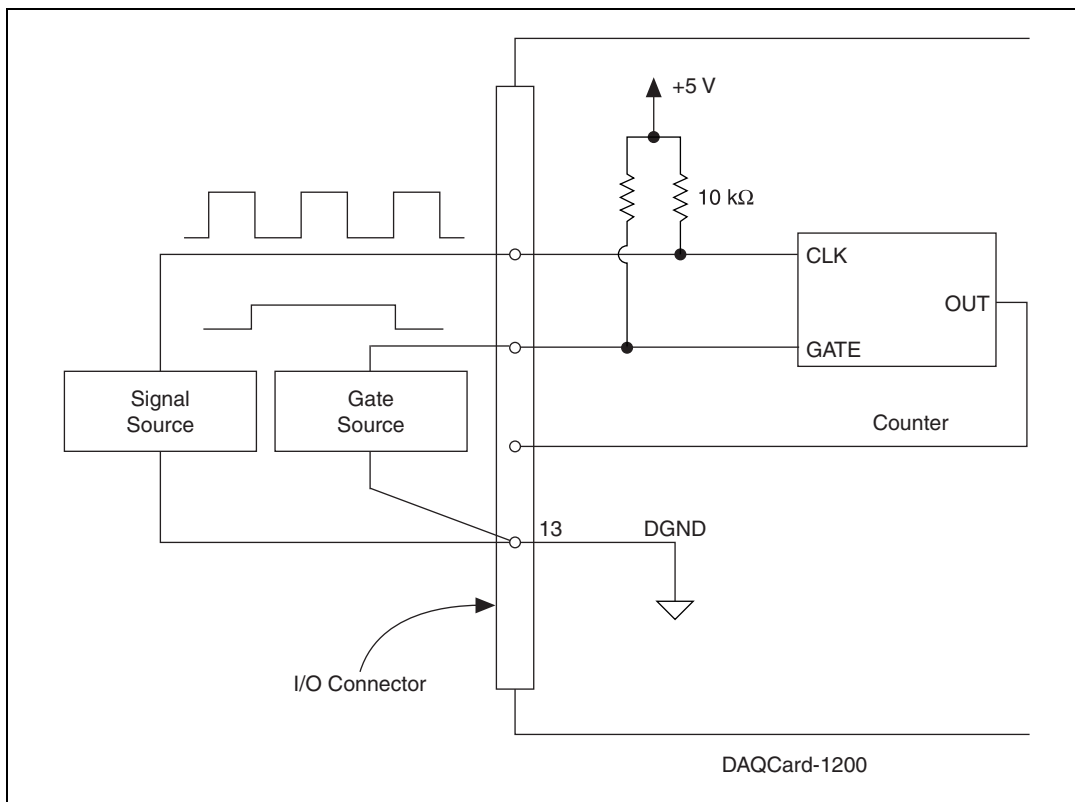

**Figure 3-18.** Event-Counting Application with External Switch Gating

Pulsewidth measurement is performed by level gating. The pulse you want to measure is applied to the counter GATE input. The counter is loaded with the known count and is programmed to count down while the signal at the GATE input is high. The pulse width equals the counter difference (loaded value minus read value) multiplied by the CLK period.

Perform time-lapse measurement by programming a counter to be edge gated. An edge is applied to the counter GATE input to start the counter. You can program the counter to start counting after receiving a low-to-high edge. The time lapse since receiving the edge equals the counter value difference (loaded value minus read value) multiplied by the CLK period.

To perform frequency measurement, program a counter to be level gated and count the number of falling edges in a signal applied to a CLK input. The gate signal applied to the counter GATE input is of known duration. In this case, you program the counter to count falling edges at the CLK input while the gate is applied. The frequency of the input signal then equals the count value divided by the gate period. Figure 3-19 shows the connections for a frequency-measurement application. You can also use a second counter to generate the gate signal in this application. In this case, program the second counter for a one-slot mode. This configuration requires an external inverter to make the output pulse of the second counter active high.



**Figure 3-19.** Frequency Measurement Application

Figure 3-20 shows the timing requirements for the GATE and CLK input signals and the timing specifications for the OUT output signals of the 82C53.

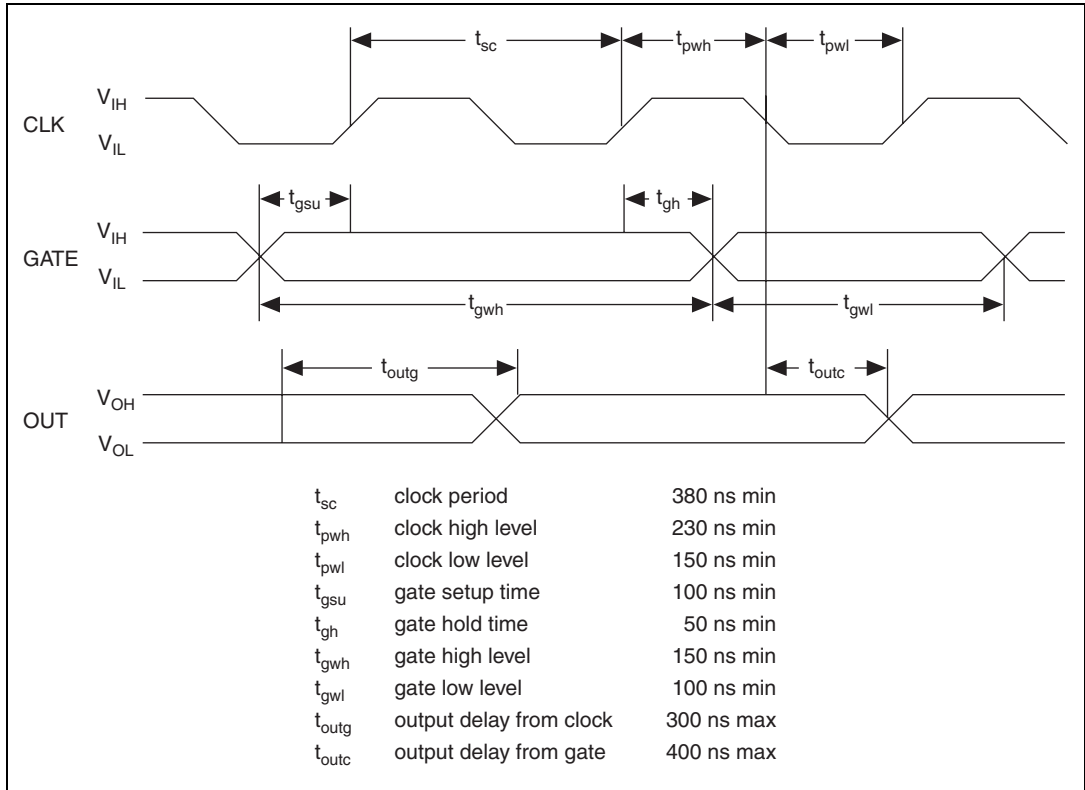

**Figure 3-20.** General-Purpose Timing Signals

The GATE and OUT signals in Figure 3-20 are referenced to the rising edge of the CLK signal.

## Connecting the Power

Pin 49 of the I/O connector supplies +5 V from the DAQCard-1200 power supply. This pin is referenced to DGND. You can use the +5 V to power external digital circuitry.

- Power rating      250 mA at +5 V maximum, fused to 1 A



**Caution** Do *not* directly connect this +5 V power pin to analog or digital ground or to any other voltage source on the DAQCard-1200 or any other device. Doing so can damage the DAQCard-1200 or the PC. NI is *not* liable for any damage due to incorrect power connections.

Pin 49 is fused for up to 1 A but should be limited to 250 mA. The fuse is a thermally resettable fuse which has an internal thermostat. This thermostat opens when the current exceeds 1 A and the temperature rises. After some time, the thermostat cools down, the switch closes, and the +5 V is available once more. Opening this fuse does not necessarily damage the DAQCard-1200. If you do not receive +5 V, check for any shorts between the +5 V power pin and ground.



# Theory of Operation

This chapter explains the operation of each functional unit of the DAQCard-1200.

## Functional Overview

The block diagram in Figure 4-1 shows a functional overview of the DAQCard-1200.

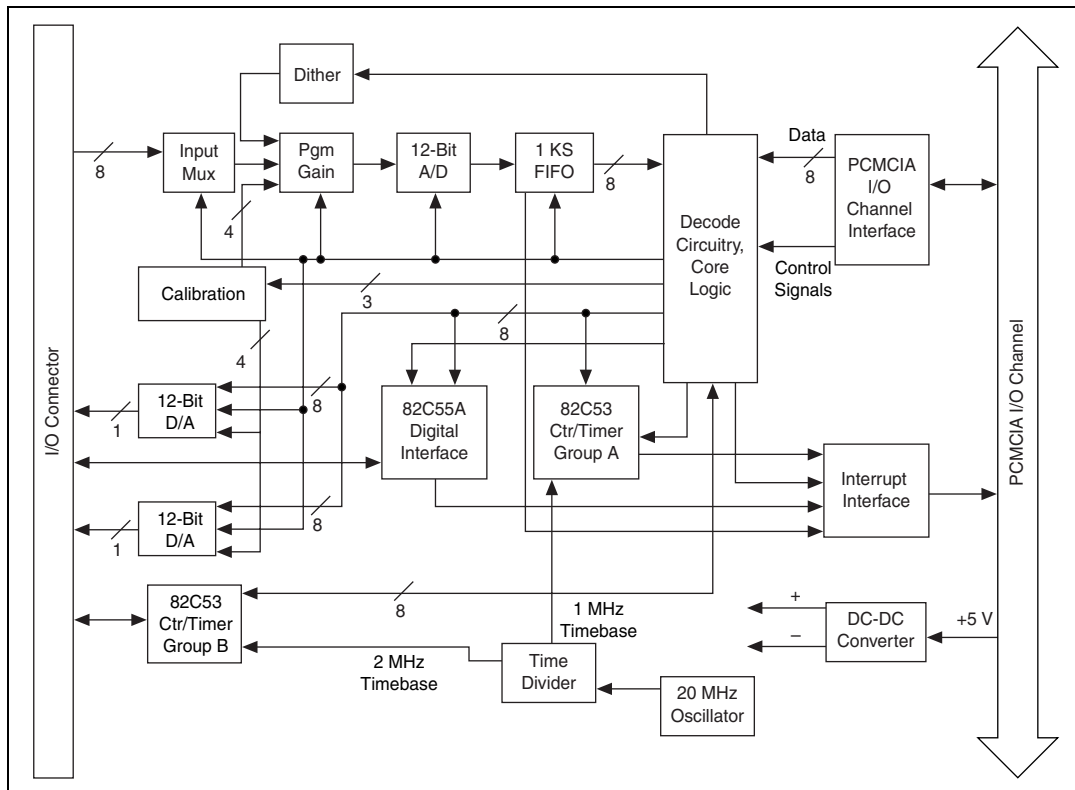

Figure 4-1. DAQCard-1200 Block Diagram

The major components of the DAQCard-1200 are as follows:

- PC Card I/O channel interface circuitry
- AI circuitry
- AO circuitry
- DIO circuitry
- Timing circuitry
- Calibration circuitry

The internal data and control buses interconnect the components. The rest of the chapter explains the theory of operation of each of the DAQCard-1200 components.

## PC Card I/O Channel Interface Circuitry

The DAQCard-1200 PC Card I/O channel interface circuitry is shown in Figure 4-2 and consists of an address bus, a data bus, interrupt lines, and several control and support signals.

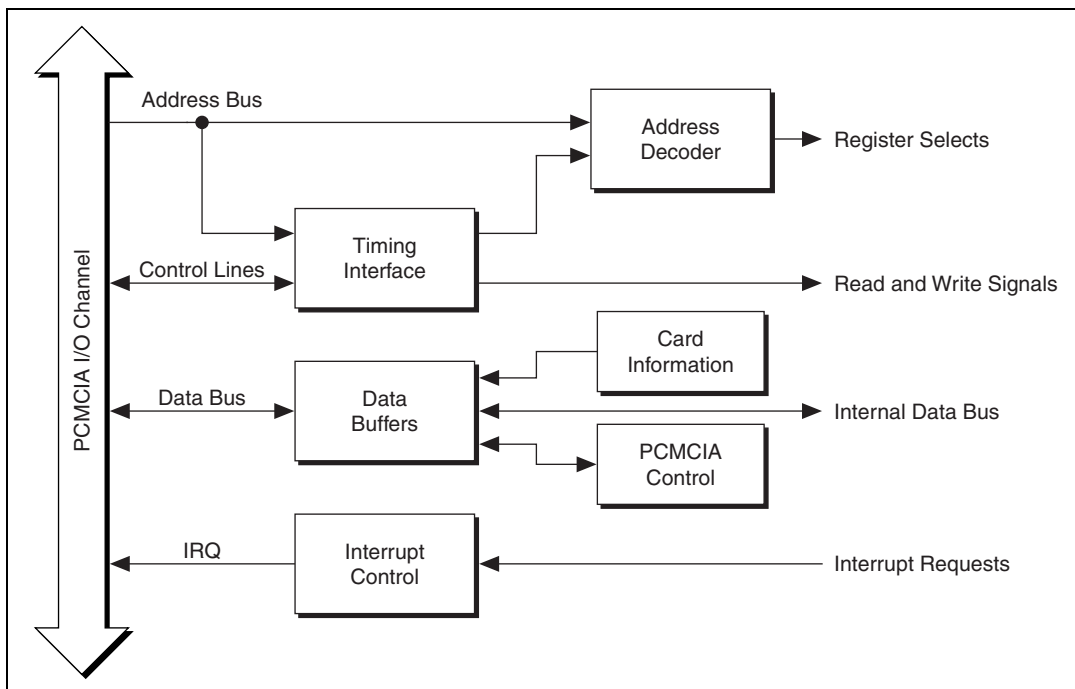

**Figure 4-2.** PC Card I/O Interface Circuitry Block Diagram

When you first insert the card into the computer, the system examines information stored in the DAQCard-1200 Card Information Structure (CIS). This data is used to configure the card appropriately for the system in which it is used. When the system has assigned the card to a section of memory, it updates the PC Card control registers and initializes the card.

The rest of the circuitry consists of address decoders, data buffers, I/O channel interface timing control circuitry, and interrupt control circuitry.

## Timing

---

The DAQCard-1200 uses two 82C53 counter/timer integrated circuits for internal data acquisition and DAC timing and for general-purpose I/O timing functions. Figure 4-3 shows a block diagram of both groups of timing circuitry (counter groups A and B).

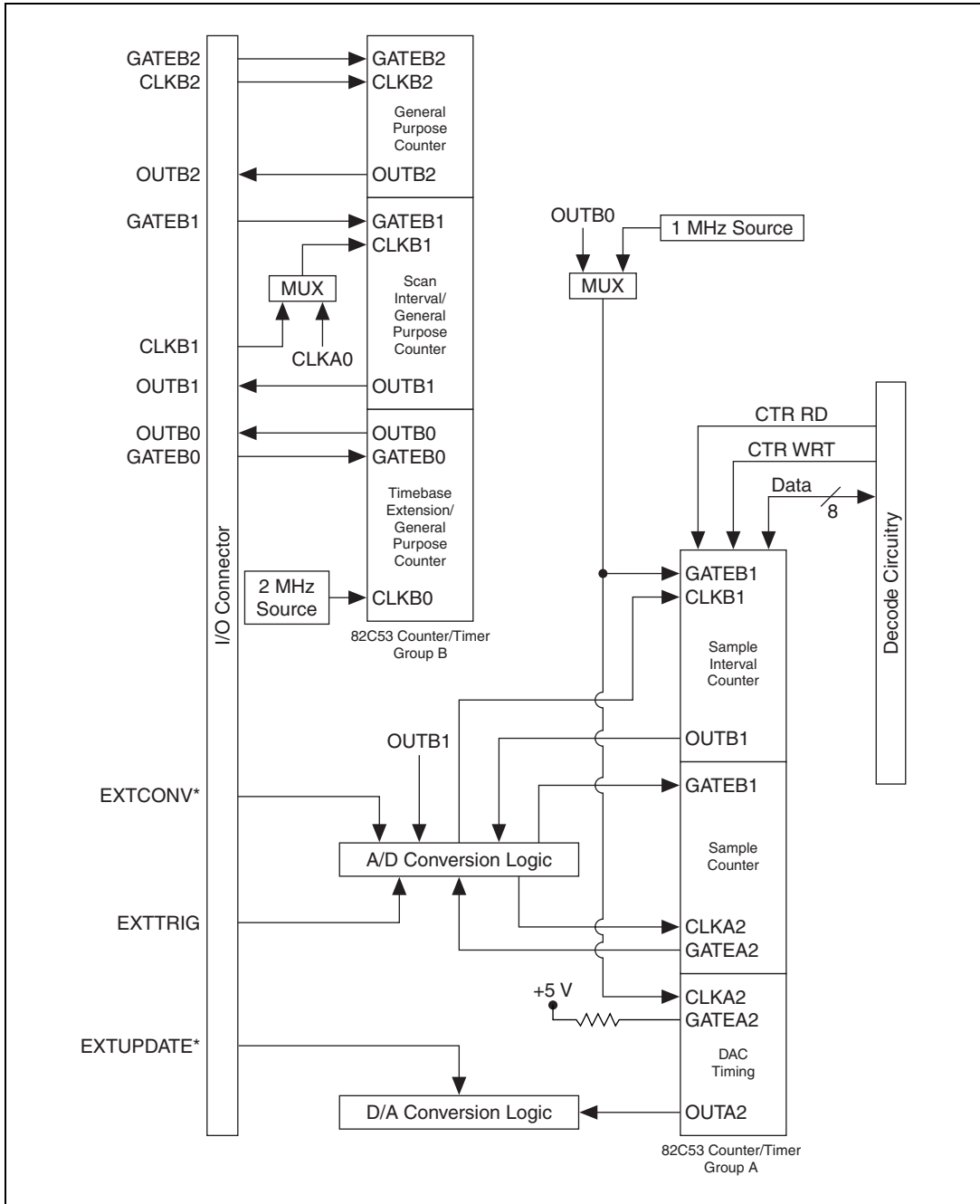

Figure 4-3. Timing Circuitry

Each 82C53 contains three independent 16-bit counter/timers and one 8-bit Mode Register. Each counter has a CLK input pin, a GATE input pin, and an OUT output pin. You can program all three counter/timers to operate in several useful timing modes.

The first group of counter/timers is called Group A and includes A0, A1, and A2. You can use these three counters for internal DAQ and DAC timing, or you can instead use the three external timing signals, EXTCONV\*, EXTTRIG and EXTUPDATE\*, for DAQ and DAC timing.

The second group of counter/timers is called Group B and includes B0, B1, and B2. You can use counters B0 and B1 for internal DAQ and DAC timing, or you can use the external timing signal CLKB1 for AI timing. If you are not using Counters B0 and B1 for internal timing, you can use these counters as general purpose counter/timers. Counter B2 is reserved for external use as a general purpose counter/timer.

For a more detailed description of Counter Group A and Counters B0 and B1, refer to the following *Analog Input* and *Analog Output* sections.

## Analog Input

---

The DAQCard-1200 has eight AI channels with software-programmable gain and 12-bit A/D conversion. The DAQCard-1200 also contains DAQ timing circuitry for automatic timing of multiple A/D conversions and includes advanced options such as external triggering, gating, and clocking. Figure 4-4 shows a block diagram of the AI circuitry.

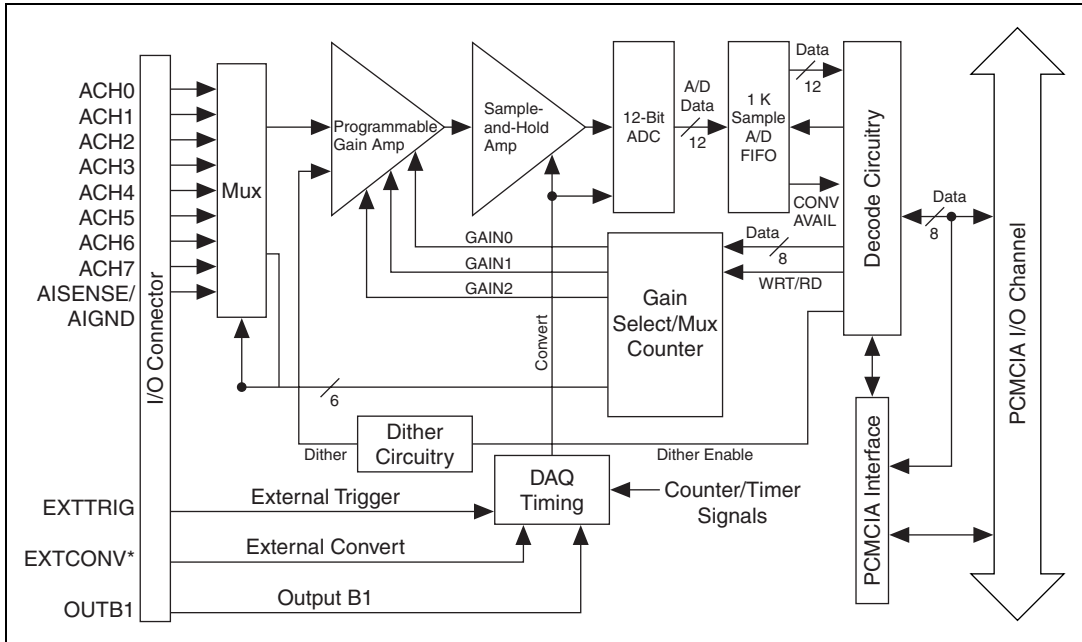

Figure 4-4. Analog Input Circuitry

## Analog Input Circuitry

The analog input circuitry consists of two analog input multiplexers, mux counter/gain select circuitry, a software-programmable gain amplifier, a 12-bit ADC, and a 12-bit FIFO memory that is sign-extended to 16 bits.

The two input multiplexers route the input channels to the instrumentation amplifier in either RSE, NRSE, or DIFF input mode. The input multiplexers provide input overvoltage protection of  $\pm 35$  V powered on and  $\pm 25$  V powered off.

The mux counters control the input multiplexers. The DAQCard-1200 can perform either single-channel data acquisition or multiple-channel (scanned) data acquisition. These two modes are software-selectable. For single-channel data acquisition, you select the channel and gain before initiating data acquisition. These gain and multiplexer settings remain constant during the entire DAQ process. For multiple-channel data acquisition, you select the highest numbered channel and gain before data acquisition is initiated. Then the mux counter decrements from the highest numbered channel to channel 0 and repeats the process. Thus you can scan any number of channels from eight to two. Notice that the same gain setting is used for all channels in the scan sequence.

The programmable gain amplifier applies gain to the input signal, allowing an analog input signal to be amplified before being sampled and converted, thus increasing measurement resolution and accuracy. The instrumentation amplifier gain is software-selectable. The DAQCard-1200 provides gains of 1, 2, 5, 10, 20, 50, and 100.

The dither circuitry, when enabled, adds approximately 0.5 LSB rms of white Gaussian noise to the signal to be converted to the ADC. This addition is useful for applications involving averaging to increase the resolution of the DAQCard-1200 to more than 12 bits, as in calibration. In such applications, which are often lower frequency in nature, noise modulation is decreased and differential linearity is improved by the addition of the dither. For high-speed 12-bit applications not involving averaging, dither should be disabled because it only adds noise.

When taking DC measurements, such as when calibrating the DAQCard-1200, enable dither and average about 1,000 points to take a single reading. This process removes the effects of 12-bit quantization and reduces measurement noise, resulting in improved resolution. Dither, or additive white noise, has the effect of forcing quantization noise to become a zero-mean random variable rather than a deterministic function of input.

The DAQCard-1200 uses a 12-bit successive-approximation ADC. The 12-bit resolution of the converter allows the converter to resolve its input range into 4,096 different steps. The ADC has an input range of  $\pm 5$  V and 0 to 10 V.

When an A/D conversion is complete, the ADC clocks the result into the A/D FIFO. This FIFO serves as a buffer to the ADC. The A/D FIFO can collect up to 1,024 A/D conversion values before any information is lost, thus allowing software some extra time to catch up with the hardware. If you store more than 1,024 samples in the A/D FIFO before reading from the A/D FIFO, an error condition called *A/D FIFO overflow* occurs and you lose A/D conversion information.

The output from the ADC can be interpreted as either straight binary or two's complement format, depending on which input mode you select (unipolar or bipolar). In unipolar mode, the data from the ADC is interpreted as a 12-bit straight binary number with a range of 0 to +4,095. In bipolar mode, the data from the ADC is interpreted as a 12-bit two's complement number with a range of  $-2,048$  to  $+2,047$ . In this mode, the MSB of the ADC result is modified to make it two's complement. The output from the ADC is then sign extended to 16 bits, causing either a leading 0 or a leading F (hex) to be added, depending on the coding and the sign. Thus, data values read from the FIFO are 16 bits wide.

## Data Acquisition Timing

A DAQ operation refers to the process of taking a sequence of A/D conversions when the sample interval, or the time between successive A/D conversions, is carefully timed. A finite DAQ operation acquires a finite number of samples, while a continuous DAQ operation acquires an infinite number of samples. The DAQCard-1200 can perform both single-channel data acquisition and multiple-channel, or scanned, data acquisition in two modes—round-robin and interval.

The DAQ timing circuitry consists of various clocks and timing signals that control the DAQ operation. DAQ timing consists of signals that initiate a DAQ operation, time the individual A/D conversions, gate the DAQ operation, and generate scan clocks. The DAQ operation can either be timed by the timing circuitry or by externally generated signals. These two modes are software configurable.

## Data Acquisition Operation

DAQ operations are initiated either externally through EXTTRIG or through software control. The DAQ operation is terminated either internally by counter A1 of the 82C53A counter/timer circuitry, which counts the total number of samples taken during a finite operation, or through software control in a continuous operation.

## Round-Robin Data Acquisition

In a round-robin DAQ operation, samples are taken at regular sample intervals without any delays. Therefore, each sample is taken with the same sample interval. This sample interval applies to both single-channel and multiple-channel data acquisition in either continuous or finite operation. The sample interval is either controlled externally by EXTCONV\* or internally by counter A0 of the timing circuitry.

## Interval Data Acquisition

In an interval DAQ operation, a period called the *scan interval* is defined. Within each scan interval, a predefined number of samples is taken at regular intervals, and conversions are stopped for the remainder of the interval cycle. A DAQ operation consists of back-to-back interval cycles. In single-channel interval data acquisition, you select the number of samples in each interval cycle from a single channel. In multiple-channel interval data acquisition, the channels are scanned once during each interval cycle. The scan interval timing can be externally controlled through OUTB1 or internally by counter B1 of the timing circuitry.



For an example of a multiple-channel interval DAQ operation, refer to the description of interval scanning signal timing in the *Analog Input Timing Connections* section of Chapter 3, *Connecting the Signals*.

## Data Acquisition Rates

Maximum DAQ rates (number of samples per second) are determined by the conversion period of the ADC plus the sample-and-hold acquisition time. During multiple-channel scanning, the acquisition rates are further limited by the settling time of the input multiplexers and programmable gain amplifier. After the input multiplexers are switched, the amplifier must settle to the new input signal value to within 12-bit accuracy before you perform an A/D conversion, or 12-bit accuracy is not achieved. The settling time is a function of the selected gain.

Table 4-1 shows the recommended settling time for each gain setting during multiple-channel scanning. Table 4-2 shows the maximum recommended acquisition rates. For single-channel scanning, this rate is limited by the ADC conversion period plus the sample-and-hold acquisition time, which is specified at 10  $\mu\text{s}$  (11  $\mu\text{s}$  if EXTCONV\* is used).

**Table 4-1.** Analog Input Settling Time Versus Gain

Gain Setting	Settling Time Recommended
1, 2, 5, 10	10 $\mu\text{s}$ max
20	12 $\mu\text{s}$ typ, 15 $\mu\text{s}$ max
50	25 $\mu\text{s}$ typ, 30 $\mu\text{s}$ max
100	60 $\mu\text{s}$ typ, 80 $\mu\text{s}$ max

**Table 4-2.** DAQCard-1200 Maximum Recommended Data Acquisition Rates

Acquisition Mode	Gain Setting	Sampling Rate
Single channel	1, 2, 5, 10, 20, 50, 100	100 kS/s
Multiple channel (observe these settings to ensure 12-bit accuracy)	1, 2, 5, 10	100 kS/s
	20	83.3 kS/s
	50	40.0 kS/s
	100	16.6 kS/s

The recommended acquisition rates in Table 4-2 assume that voltage levels on all the channels included in the scan sequence are within range for the given gain and are driven by low-impedance sources.



**Note** If you use external conversions for single-channel acquisitions, the maximum sampling rate is 90 kS/s.

## Analog Output

The DAQCard-1200 has two channels of 12-bit D/A output. Each AO channel can provide unipolar or bipolar output. The DAQCard-1200 also contains timing circuitry for waveform generation timed either externally or internally. Figure 4-5 shows the AO circuitry.

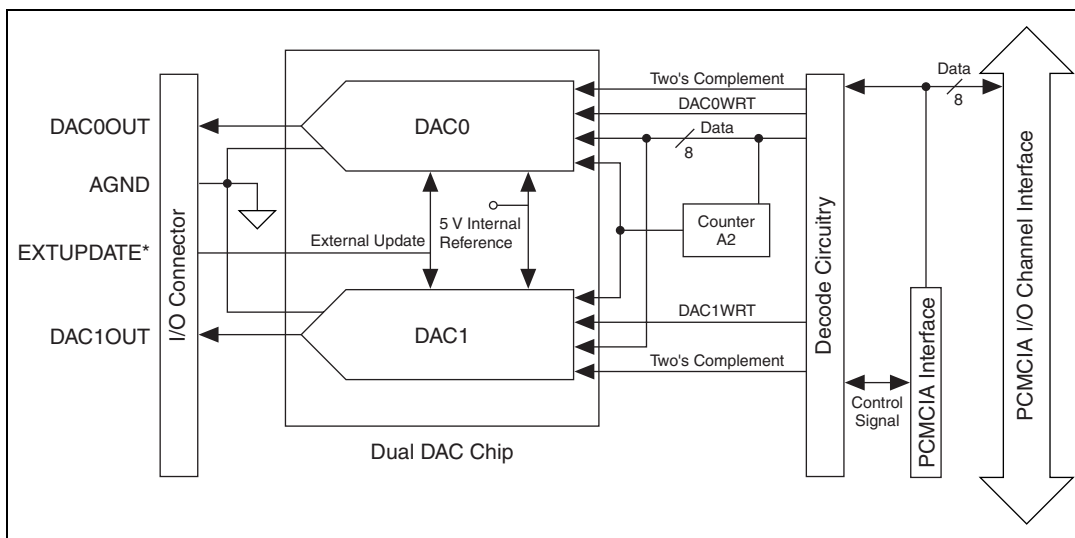

**Figure 4-5.** Analog Output Circuitry

### Analog Output Circuitry

Each AO channel contains a 12-bit DAC. The DAC in each AO channel generates a voltage proportional to the 5 V reference (provided in the Dual DAC chip) multiplied by the 12-bit digital code loaded into the DAC. The voltage output from the two DACs is available at the DAQCard-1200 I/O connector DAC0OUT and DAC1OUT pins.

You can program each DAC channel for a unipolar voltage output or a bipolar voltage output range. A unipolar output gives an output voltage

range of 0 to +10 V. A bipolar output gives an output voltage range of  $\pm 5$  V. For unipolar output, 0 V output corresponds to a digital code word of 0. For bipolar output, -5 V output corresponds to a digital code word of F800 hex. One least significant bit (LSB) is the voltage increment corresponding to an LSB change in the digital code word. For both outputs:

$$1LSB = \frac{10}{4096} V$$

## Power-On State

Both analog outputs reach 0 V approximately 110 ms after card insertion. During this 110 ms period, the output voltage can swing from +2 to -5 V.



**Caution** Disconnect the analog outputs from the system before inserting the card in the PC Card slot. This step ensures that you do not damage the system during the 110 ms before the output reaches 0 V.

## DAC Timing

There are two ways you can update the DAC voltages. In the first mode, the DAC output voltage is updated as soon as you write to the corresponding DAC. This mode is called the immediate update mode. In the second mode, the DAC output voltage does not change until a low level is detected either from counter A2 of the timing circuitry or from EXTUPDATE\*. This mode is useful for waveform generation. These two modes are software-selectable.



**Note** Configure both DACs in either immediate update mode or later update mode. Do not configure the DACs in a combination of both modes because doing so can result in premature updates on the waveform generation DAC (whenever the immediate update DAC is updated). Also, if a waveform generation update occurs between an LSB write and an MSB write of the DAC in the immediate update mode, you receive an incorrect value from that DAC until the MSB is written. Both of these effects are minimal at high waveform update rates.



**Note** Delayed update mode is selected by NI-DAQ when a timed, or buffered, AO operation is configured.

## Digital I/O

The DIO circuitry has an 82C55A integrated circuit. The 82C55A is a general-purpose programmable peripheral interface (PPI) containing 24 programmable I/O pins. These pins represent the three 8-bit I/O ports (A, B, and C) of the 82C55A, as well as PA<0..7>, PB<0..7>, and PC<0..7> on the DAQCard-1200 I/O connector. Figure 4-6 shows the DIO circuitry.

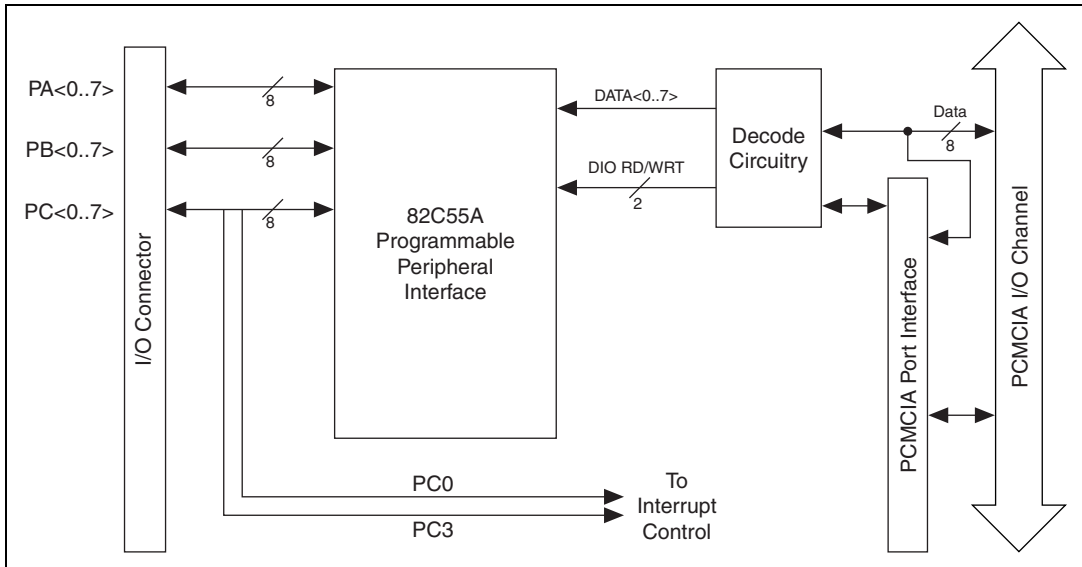

**Figure 4-6.** Digital I/O Circuitry

All three ports on the 82C55A are TTL-compatible. When enabled, the digital output ports are capable of sinking 2.4 mA of current and sourcing 2.6 mA of current on each DIO line. When the ports are not enabled, the DIO lines act as high-impedance inputs.

---

# Calibration

This chapter discusses calibrating the DAQCard-1200. NI-DAQ includes calibration functions for performing all the steps in the calibration process.

Calibration refers to the process of minimizing measurement and output voltage errors by making small circuit adjustments. On the DAQCard-1200, these adjustments take the form of writing values to onboard calibration DACs (CalDACs).

Some form of device calibration is required for most applications. If you do not calibrate your device, your signals and measurements could have very large offset, gain, and linearity errors.

## Loading Calibration Constants

---

The DAQCard-1200 device is factory calibrated at approximately 25 °C to the levels indicated in Appendix A, *Specifications*. The associated calibration constants—the values that were written to the CalDACs to achieve calibration in the factory—are stored in the onboard nonvolatile memory (EEPROM). Because the CalDACs have no memory capability, they do not retain calibration information when the device is powered down. Loading calibration constants refers to the process of loading the CalDACs with the values stored in the EEPROM. NI-DAQ determines when this is necessary and does it automatically.

The EEPROM has a user-modifiable calibration area in addition to the permanent factory calibration area. Hence, you can load the CalDACs with values either from the original factory calibration or from a calibration that you subsequently performed.

This method of calibration is not very accurate because it does not take into account the fact that the device measurement and output voltage errors can vary with time and temperature. Self-calibrate the device when it is installed in the environment in which it is used.

## Self-Calibration

---

The DAQCard-1200 can measure and correct for almost all of its calibration-related errors without any external signal connections. NI-DAQ provides a self-calibration function. This self-calibration process, which generally takes less than two minutes, is the preferred method of assuring accuracy in your application. Initiate self-calibration to minimize the effects of any offset and gain drifts, particularly those due to warm-up.

Immediately after self-calibration, the only significant residual calibration error could be gain error due to time or temperature drift of the onboard voltage reference. This error is addressed by external calibration. If you are interested primarily in relative measurements, you can ignore a small amount of gain error, and self-calibration should be sufficient.

## External Calibration

---

The DAQCard-1200 has an onboard calibration reference to ensure the accuracy of self-calibration. Its specifications are listed in Appendix A, *Specifications*. The reference voltage is measured at the factory and stored in the EEPROM for subsequent self-calibrations. This voltage is stable enough for most applications, but if you use your device at an extreme temperature or if the onboard reference has not been measured for a year or more, you may wish to externally calibrate your device.

An external calibration refers to calibrating your device with a known external reference rather than relying on the onboard reference. Redetermining the value of the onboard reference is part of this process and the results can be saved in the EEPROM. You can externally calibrate your device by calling the NI-DAQ calibration function.

To externally calibrate your device, be sure to use a very accurate external reference. The reference should be 4–10 times more accurate than the device itself.

## Specifications

This appendix lists the specifications for the DAQCard-1200. These specifications are typical at 25 °C unless otherwise noted.

### Analog Input

#### Input Characteristics

Number of channels ..... 8 single-ended,  
 8 pseudodifferential, or  
 4 differential, software-selectable

Resolution ..... 12 bits, 1 in 4,096

Max single-channel sampling rate ..... 100 kS/s

Input signal ranges

Device Gain (Software-Selectable)	Device Range (Software-Selectable)	
	Unipolar	Bipolar
1	0 to 10 V	±5 V
2	0 to 5 V	±2.5 V
5	0 to 2 V	±1 V
10	0 to 1 V	±500 mV
20	0 to 500 mV	±250 mV
50	0 to 250 mV	±100 mV
100	0 to 100 mV	±50 mV

Input coupling ..... DC

Type of ADC ..... Successive approximation

Maximum working voltage (signal + common mode) .....	Negative input/AISENSE should remain within $\pm 6$ V (bipolar) or $-6$ to $2$ V (unipolar) of AGND
Overvoltage protection .....	$\pm 35$ V powered on and $\pm 25$ V powered off
Inputs protected .....	ACH<0..7>
FIFO buffer size.....	1,024 samples
Data transfers .....	Interrupts, programmed I/O
Dither .....	Available

## Transfer Characteristics

Relative accuracy .....	$\pm 0.5$ LSB typ dithered, $\pm 1.5$ LSB max undithered
DNL .....	$\pm 1$ LSB max
No missing codes.....	12 bits, guaranteed
Offset error	
Pre-gain error after calibration .....	$10 \mu\text{V}$ max
Pre-gain error before calibration .....	$\pm 20$ mV max
Post-gain error after calibration.....	$1$ mV max
Post-gain error before calibration.....	$\pm 200$ mV max
Gain error (relative to calibration reference)	
After calibration.....	$0.02\%$ of reading max
Before calibration .....	$\pm 2\%$ of reading max
Gain $\neq 1$ with gain error adjusted to 0 at gain = 1.....	$\pm 0.8\%$ of reading max

## Amplifier Characteristics

Input impedance	
Normal powered on .....	$100 \text{ G}\Omega$ in parallel with $50 \text{ pF}$
Powered off .....	$4.7 \text{ k}\Omega$ min
Overload .....	$4.7 \text{ k}\Omega$ min



Input bias current .....  $\pm 100$  pA

Input offset current.....  $\pm 100$  pA

CMRR ..... 70 dB, DC to 60 Hz

## Dynamic Characteristics

Bandwidth

Small signal ( $-3$  dB)

Gain	Bandwidth
1–10	250 kHz
20	150 kHz
50	60 kHz
100	30 kHz

Settling time to full scale step

Gain	Accuracy
	$\pm 0.024\%$ ( $\pm 1$ LSB)
1–10	10 $\mu$ s max
20	12 $\mu$ s typ, 15 $\mu$ s max
50	25 $\mu$ s typ, 30 $\mu$ s max
100	60 $\mu$ s typ, 80 $\mu$ s max

System noise (not including quantization error)

Gain	Dither Off	Dither On
1–50	0.3 $\text{LSB}_{\text{rms}}$	0.5 $\text{LSB}_{\text{rms}}$
100	0.5 $\text{LSB}_{\text{rms}}$	0.7 $\text{LSB}_{\text{rms}}$

## Stability

Recommended warm-up time.....	15 minutes
Offset temperature coefficient	
Pre-gain.....	$\pm 15 \mu\text{V}/^\circ\text{C}$
Post-gain.....	$\pm 100 \mu\text{V}/^\circ\text{C}$
Gain temperature coefficient .....	$\pm 40 \text{ ppm}/^\circ\text{C}$

## Analog Output

### Output Characteristics

Number of Channels.....	2 voltage
Resolution.....	12 bits, 1 in 4,096
Max update rate .....	20 kS/s <sup>1</sup>
Type of DAC .....	Double buffered
Data transfers.....	Interrupts, programmed I/O

### Transfer Characteristics

Relative accuracy (INL) .....	$\pm 0.5 \text{ LSB typ, } \pm 1 \text{ LSB max}$
DNL.....	$\pm 0.5 \text{ LSB typ, } \pm 0.9 \text{ LSB max}$
Monotonicity .....	12 bits, guaranteed
Offset error	
After calibration.....	$\pm 0.5 \text{ mV max}$
Before calibration .....	$\pm 75 \text{ mV max}$
Gain error (relative to internal reference)	
After calibration.....	$\pm 0.02\% \text{ of reading max}$
Before calibration .....	$\pm 2\% \text{ of reading max}$

---

<sup>1</sup> If you perform simultaneous AI and AO, reliable continuous rates are limited to 0.5 to 1 kS/s and are configuration dependent.

## Voltage Output

Ranges .....	0 to 10 V, $\pm 5$ V software selectable
Output coupling .....	DC
Output impedance .....	0.5 $\Omega$ typ
Current drive .....	1 mA max per channel
Protection .....	80 mA momentary short-circuit protection to ground
Power-on state	
0 to 110 ms .....	+2 V to -5 V
>110 ms .....	0 V ( $\pm$ mV)

## Dynamic Characteristics

Settling time to full-scale step .....	20 $\mu$ s to $\pm 1$ LSB accuracy
Noise .....	400 $\mu$ V <sub>rms</sub> typ, DC to 1 MHz

## Stability

Offset temperature coefficient .....	$\pm 50$ $\mu$ V/ $^{\circ}$ C
Gain temperature coefficient .....	$\pm 30$ ppm/ $^{\circ}$ C

## Digital I/O

Number of channels .....	24 I/O (three 8-bit ports; uses the 82C55A PPI)
Compatibility .....	TTL
Power-on state .....	All ports high-impedance inputs

Digital logic levels

Level	Min	Max
Input low voltage	-0.3 V	0.8 V
Input high voltage	2.2 V	5.3 V
Output low voltage ( $I_{out} = 2.5 \text{ mA}$ )	—	0.4 V
Output high voltage ( $I_{out} = -40 \text{ }\mu\text{A}$ ) ( $I_{out} = -2.5 \text{ mA}$ )	4.2 V 3.7 V	— —
Output leakage current $0 \leq V_{out} \leq V_{cc}$	-10 $\mu\text{A}$	10 $\mu\text{A}$

Protection .....-0.5 to 5.5 V powered on,  
 $\pm 0.5 \text{ V}$  powered off

Handshaking .....3 wire, 2 port

Data transfers .....Interrupts, programmed I/O

## Timing I/O

Number of channels .....3 counters/timers

Digital logic levels

Level	Min	Max
Input low voltage	-0.3 V	0.8 V
Input high voltage	2.2 V	5.3 V
Output low voltage ( $I_{out} = 4 \text{ mA}$ )	—	0.45 V
Output high voltage ( $I_{out} = -1 \text{ mA}$ )	3.7 V	—

Protection .....	-0.5 to 5.5 V powered on, ±0.5 V powered off
Resolution	
Counters/timers .....	16 bits
Compatibility .....	TTL
Base clocks available .....	2 MHz
Base clock accuracy .....	±50 ppm max
Max source frequency .....	8 MHz
Min source pulse duration.....	125 ns
Min gate pulse duration.....	100 µs
Data transfers .....	Interrupts, programmed I/O

## Digital Trigger

Compatibility .....	TTL
Response .....	Rising edge
Pulse width.....	50 ns min

## Bus Interface

Slave

## Power Requirement

+5 VDC (±5%).....	150 mA operating, 50 mA power-down mode, plus any current drawn through the I/O connector +5 line
-------------------	--

## Physical

Dimensions.....	8.56 by 5.40 cm (3.37 by 2.13 in.)
PC Card type .....	Type II
I/O connector.....	50-pin male

## Maximum Working Voltage

Maximum working voltage refers to the signal voltage plus the common-mode voltage.

Channel-to-earth .....30 VAC or 60 VDC,  
installation category I

Channel-to-channel.....30 VAC or 60 VDC,  
installation category I

## Environmental

Operating temperature .....0 to 50 °C

Storage temperature .....-55 to 150 °C

Humidity .....5% to 90% RH, noncondensing

Maximum altitude.....2000 meters

Pollution degree (indoor use only) .....2

## Safety

The DAQCard-1200 meets the requirements of the following standards for safety and electrical equipment for measurement, control, and laboratory use:

- EN 61010-1:1993/A2:1995, IEC 61010-1:1990/A2:1995
- UL 3111-1:1994
- CAN/CSA c22.2 no. 1010.1:1992/A2:1997

## Electromagnetic Compatibility

CE, C-Tick, and FCC Part 15 (Class A) Compliant

Electrical emissions .....EN 55011 Class A at 10 m  
FCC Part 15A above 1 GHz

Electrical immunity .....Evaluated to EN 61326:1997/  
A1:1998, Table 1



**Note** For full EMC compliance, you must operate this device with shielded cabling. In addition, all covers and filler panels must be installed. Refer to the Declaration of Conformity (DoC) for this product for any additional regulatory compliance information.

To obtain the DoC for this product, click **Declaration of Conformity** at [ni.com/hardref.nsf/](http://ni.com/hardref.nsf/). This web site lists the DoCs by product family. Select the appropriate product family, followed by your product, and a link to the DoC appears in Adobe Acrobat format. Click the Acrobat icon to download or read the DoC.

# Differences among the Lab-PC+, the DAQPad-1200, and the DAQCard-1200

This appendix contains a summary of the functional differences between the Lab-PC+, the DAQPad-1200, and the DAQCard-1200.

The Lab-PC+ is a plug-in DAQ device for PCs. It has jumpers for allocating bus resources such as base address, interrupt, and DMA channels, as well as analog input/output resources such as input/output mode and polarity. It also has potentiometers for calibration.

The DAQPad-1200 is a DAQ device that plugs into the parallel port of the computer. It is functionally identical to the Lab-PC+. In addition, there are no jumpers for bus resource allocation; this is done at configuration time with software. It also has no potentiometers because it is software calibrated. The DAQPad-1200 is register-compatible with the Lab-PC+. It has a few additional registers for calibration purposes.

The DAQCard-1200 is register-compatible with the DAQPad-1200 (and the Lab-PC+) and is functionally identical to it. Register-level software developed for the Lab-PC+ works directly on a configured DAQCard-1200. However, you calibrate the DAQCard-1200 with software instead of with potentiometers.



The following table summarizes the differences among the three products.

Functionality	Lab-PC+	DAQPad-1200	DAQCard-1200
Bus resource allocation	Jumpers	Software	Software (automatic)
Calibration	Potentiometers	Software	Software
DMA	Uses DMA	Cannot use DMA	Cannot use DMA
Waveform generation	Can do waveform generation on one DAC and immediate updates on the other DAC	Can do waveform generation on one DAC and immediate updates on the other	Should do either immediate update on both or waveform generation on both but not a combination. Refer to Chapter 4, <i>Theory of Operation</i> , for more information.
FIFO size	512 samples	1,024 samples	1,024 samples
Maximum single-channel acquisition rate	83.3 kS/s	100 kS/s	100 kS/s
Power-management modes	—	—	150 mA operating, 50 mA power-down mode
Fuse	Regular 250 mA	Regular 250 mA	Thermal 1.0 A



---

# Common Questions

This appendix contains a list of common questions and answers relating to the operation of the DAQCard-1200. The questions are grouped according to the type of information requested.

## Installing and Configuring the DAQCard-1200

---

**Which NI documentation should I read first to get started using DAQ software?**

Refer to the [Configuring the DAQCard-1200](#) section in Chapter 2, [Installing and Configuring the DAQCard-1200](#), for this information.

**What version of NI-DAQ must I have to program the DAQCard-1200?**

The DAQCard-1200 is supported by NI-DAQ for Windows versions 6.9.x and earlier. You may also use the DAQCard-1200 with NI-DAQ for Mac OS version 6.6.x or version 4.9.4 or earlier.

**What is the best way to test the DAQCard without having to program the DAQCard?**

If you are using Windows, MAX has a Test Panel option that is available by clicking **Devices and Interfaces** and then clicking the device. The Test Panels are excellent tools for performing simple functional tests of the DAQCard, such as analog input and output, digital I/O, and counter/timer tests. If you are using Mac OS, the NI-DAQ Configuration Utility provides the same functionality.

## Operating the DAQCard-1200

---

**When using the DAQCard in differential analog input mode, I have connected a differential input signal, but the readings are random and drift rapidly. What's wrong?**

Check the ground-reference connections. The signal may be referenced to a level that is considered *floating* with reference to the DAQCard ground reference. Even if you are in differential mode, the signal *must* still be

referenced to the same ground level as the DAQCard reference. Chapter 3, *Connecting the Signals*, outlines the various methods used to achieve the same ground level while maintaining a high CMRR.

**I want to use NI-DAQ to program the DAQCard-1200. How can I determine which NI-DAQ functions support the DAQCard?**

If you are using NI-DAQ 6.7 or later, refer to the NI-DAQ Function Reference Online Help file. Click **NI-DAQ Functions»Listed by Hardware Product** for a complete list of functions supported by the DAQCard-1200. If you are using NI-DAQ 6.6 or earlier, refer to Appendix C, *NI-DAQ Function Support*, of the *NI-DAQ Function Reference Manual for PC Compatibles*.

**I wish to register-level program the DAQCard-1200. Where can I find the information that I need to accomplish this task?**

Register-level programming is not recommended for most users. Even experienced register-level programmers will find that using the NI-DAQ, LabVIEW, or Measurement Studio ADE is as easy and as flexible as register-level programming and can save weeks of development time. However, if you choose to register-level program, you can download the *DAQCard-1200 Register-Level Programmer Manual* from [ni.com/manuals](http://ni.com/manuals).

---

# Technical Support Resources

## Web Support

---

NI Web support is your first stop for help in solving installation, configuration, and application problems and questions. Online problem-solving and diagnostic resources include frequently asked questions, knowledge bases, product-specific troubleshooting wizards, manuals, drivers, software updates, and more. Web support is available through the Technical Support section of [ni.com](http://ni.com).

## NI Developer Zone

---

The NI Developer Zone at [ni.com/zone](http://ni.com/zone) is the essential resource for building measurement and automation systems. At the NI Developer Zone, you can easily access the latest example programs, system configurators, tutorials, technical news, as well as a community of developers ready to share their own techniques.

## Customer Education

---

NI provides a number of alternatives to satisfy your training needs, from self-paced tutorials, videos, and interactive CDs to instructor-led hands-on courses at locations around the world. Visit the Customer Education section of [ni.com](http://ni.com) for online course schedules, syllabi, training centers, and class registration.

## System Integration

---

If you have time constraints, limited in-house technical resources, or other dilemmas, you may prefer to employ consulting or system integration services. You can rely on the expertise available through our worldwide network of Alliance Program members. To find out more about our Alliance system integration solutions, visit the System Integration section of [ni.com](http://ni.com).

## Worldwide Support

---

NI has offices located around the world to help address your support needs. You can access our branch office Web sites from the Worldwide Offices section of [ni.com](http://ni.com). Branch office Web sites provide up-to-date contact information, support phone numbers, e-mail addresses, and current events.

If you have searched the technical support resources on our Web site and still cannot find the answers you need, contact your local office or NI corporate. Phone numbers for our worldwide offices are listed at the front of this manual.

# Glossary

---

Prefix	Meanings	Value
p-	pico-	$10^{-12}$
n-	nano-	$10^{-9}$
$\mu$ -	micro-	$10^{-6}$
m-	milli-	$10^{-3}$
k-	kilo-	$10^3$
M-	mega-	$10^6$
G-	giga-	$10^9$
t-	tera-	$10^{12}$

## Numbers/Symbols

° degrees

$\Omega$  ohms

% percent

## A

A amperes

A/D analog-to-digital

AC alternating current

ACH analog input channel signal

ACK Acknowledge Input—A low signal on this handshaking line indicates that the data written from the specified port has been accepted; primarily a response from the external device that it has received data

ADC	analog-to-digital converter—an electronic device, often an integrated circuit, that converts an analog voltage to a digital number
ADE	application development environment
AGND	analog output ground reference signal for analog output voltages
AI	analog input
AIGND	analog input ground signal
AISENSE	analog input sense signal
AO	analog output
AWG	American Wire Gauge
<b>B</b>	
BCD	binary-coded decimal
bipolar	a signal range that includes both positive and negative values (for example, -5 V to +5 V)
bit	one binary digit, either 0 or 1
buffer	temporary storage for acquired or generated data (software)
byte	eight related bits
<b>C</b>	
C	Celsius
CalDAC	calibration DAC
CE	card enable signal
CLK	clock input signal
CMOS	complementary metallic oxide semiconductor

CMRR	common-mode rejection ratio—a measure of an instrument’s ability to reject interference from a common-mode signal, usually expressed in decibels (dB)
<b>D</b>	
D/A	digital-to-analog
DAC	digital-to-analog converter
DAQ	data acquisition—(1) collecting and measuring electrical signals from sensors, transducers, and test probes or fixtures and inputting them to a computer for processing; (2) collecting and measuring the same kinds of electrical signals with A/D and/or DIO devices plugged into a computer, and possibly generating control signals with D/A and/or DIO devices in the same computer
DATA	Data Lines at the Specified Port—the signal that indicates when the data on the data lines at a specified port is or should be available
dB	decibel
DC	direct current
DGND	digital ground signal
DI	digital input
DIFF	differential input mode
DIN	digital input signal
DIO	digital input/output
DMA	direct memory access—a method by which data can be transferred to/from computer memory from/to a device or memory on the bus while the processor does something else. DMA is the fastest method of transferring data to/from computer memory.
DNL	differential nonlinearity—a measure in least significant bit of the worst-case deviation of code widths from their ideal value of 1 LSB



DO digital output  
DOUT digital output signal

## **E**

EEPROM electrically erasable programmable read-only memory—ROM that can be erased with an electrical signal and reprogrammed  
EISA Extended Industry Standard Architecture  
ESP Engineering Software Package  
EXTCONV external control signal to trigger A/D conversions  
EXTINT external interrupt signal  
EXTTRIG External Trigger—external control signal to trigger a DAQ operation  
EXTUPDATE External Update—external control signal to update DAC outputs

## **F**

F farads  
FIFO first-in first-out memory buffer—the first data stored is the first data sent to the acceptor. FIFOs are often used on DAQ devices to temporarily store incoming or outgoing data until that data can be retrieved or output. For example, an analog input FIFO stores the results of A/D conversions until the data can be retrieved into system memory, a process that requires the servicing of interrupts and often the programming of the DMA controller. This process can take several milliseconds in some cases. During this time, data accumulates in the FIFO for future retrieval. With a larger FIFO, longer latencies can be tolerated. In the case of analog output, a FIFO permits faster update rates, because the waveform data can be stored on the FIFO ahead of time. This again reduces the effect of latencies associated with getting the data from system memory to the DAQ device.

**G**

gain	The factor by which a signal is amplified, often expressed in dB.
GATE	gate input signal
glitch	an unwanted momentary deviation from a desired signal

**H**

hex	hexadecimal
Hz	hertz—the number of scans read or updates written per second

**I**

I/O	input/output—the transfer of data to/from a computer system involving communications channels, operator interface devices, and/or data acquisition and control interfaces
IBF	Input Buffer Full—A high signal on this handshaking line indicates that data has been loaded into the input latch; primarily an input acknowledge signal
in.	inches
interchannel delay	another name for the sample interval, the time between when the first channel in the scan is sampled and when that channel is sampled again
INTR	Interrupt Request—a signal that becomes high when the 82C55A requests service during a data transfer
ISA	Industry Standard Architecture

**K**

K	the prefix denoting 1,024, or $2^{10}$
---	--

## **L**

LED	light-emitting diode
LSB	least significant bit

## **M**

MAX	Measurement and Automation Explorer—National Instruments software that allows you to interface with and configure NI devices
MB	megabytes of memory
MSB	most significant bit

## **N**

NC	not connected (signal)
NI	National Instruments
NI-DAQ	National Instruments driver software for DAQ hardware
NRSE	nonreferenced single-ended mode—all measurements are made with respect to a common (NRSE) measurement system reference, but the voltage at this reference can vary with respect to the measurement system ground

## **O**

OBF	Output Buffer Full—a low signal on this handshaking line indicates that data has been written from the specified port
OUT	output signal

**P**

PCMCIA an expansion bus architecture that has found widespread acceptance as a de facto standard in notebook-size computers. It originated as a specification for add-on memory cards written by the Personal Computer Memory Card International Association.

PPI programmable peripheral interface

**R**

RAM random-access memory

RD Read—the read signal generated from the parallel port interface circuitry

RH relative humidity

RMA Return Material Authorization

rms root mean square

RSE referenced single-ended mode—input mode where the negative input of the instrumentation amplifier is referenced to AISENSE/AIGND, which is tied to ground through about 200  $\Omega$  resistance (default setting for the DAQCard-1200)

RTD resistance temperature detector

**S**

S samples

s seconds

SCXI Signal Conditioning eXtensions for Instrumentation—the National Instruments product line for conditioning low-level signals within an external chassis near sensors so only high-level signals are sent to DAQ devices in the noisy PC environment

STB Strobe Input—A low signal on this handshaking line loads data into the input latch

## T

TIO	timing input/output
TTL	transistor-transistor logic
two's complement	given a number $x$ expressed in base 2 with $n$ digits to the left of the radix point, the (base 2) number $2^n - x$

## U

unipolar	a signal range that is always positive (for example, 0 to +10 V)
----------	--

## V

V	volts
VAC	volts, alternating current
$V_{CC}$	positive supply voltage from the PCMCIA bus (usually +5V)
VDC	volts, direct current
VI	virtual instrument—(1) a combination of hardware and/or software elements, typically used with a PC, that has the functionality of a classic stand-alone instrument (2) a LabVIEW software module (VI), which consists of a front panel user interface and a block diagram program
$V_{IH}$	volts, input high
$V_{IL}$	volts, input low
$V_{in}$	volts in
$V_{OH}$	volts, output high
$V_{OL}$	volts, output low

## W

WRT	Write—the write signal generated from the parallel port interface circuitry
-----	---

# Index

---

## Symbols

+5 V signal (table), 3-4

## A

ACH<0..7> signal

description (table), 3-3

signal ranges, 3-4

bipolar and unipolar analog input  
(table), 3-5

ACK\* signal (table), 3-18

AGND signal

analog input signal connections, 3-4

description (table), 3-3

AISENSE/AIGND signal

analog common signal, 3-4

description (table), 3-3

amplifier characteristic specifications, A-2

analog input

*See also* analog input modes; analog input  
signal connections

circuitry, 4-6

configuration

analog I/O settings (table), 2-3

default settings, 2-3

input modes, 2-4

input polarity, 2-4

data acquisition rates

maximum recommended rates  
(table), 4-9

settling time versus gain (table), 4-9

data acquisition timing

continuous data acquisition, 4-8

data acquisition operation, 4-8

interval data acquisition, 4-8

polarity

configuration, 2-4

settings (table), 2-3

specifications

amplifier characteristics, A-2

dynamic characteristics, A-3

input characteristics, A-1

stability, A-4

transfer characteristics, A-2

theory of operation, 4-5

analog input modes

configurations

differential connection

considerations, 3-7

floating signal sources, 3-8

ground-referenced signal sources, 3-10

recommended input configurations  
(table), 3-7

DIFF

definition (table), 2-4

purpose and use, 2-4

NRSE

definition (table), 2-4

purpose and use, 2-5

RSE

definition (table), 2-4

purpose and use, 2-5

analog input signal connections

bipolar and unipolar signal range versus  
gain (table), 3-5

common-mode signal rejection, 3-13

differential connections

description, 3-7

floating signal sources, 3-8

grounded signal sources, 3-10

single-ended connections, 3-11

when to use, 3-8

- exceeding maximum input voltage ratings (caution), 3-4
- floating signal sources, 3-6
- ground-referenced signal sources, 3-6
- input configurations, 3-7
- instrumentation amplifier, 3-5
- pins, 3-3
- recommended input configurations (table), 3-7
- single-ended connections
  - floating signal sources (RSE configuration), 3-11
  - grounded signal sources (NRSE configuration), 3-12
  - purpose and use, 3-11
  - when to use, 3-11
- types of signal sources, 3-6
- analog output
  - circuitry, 4-10
  - DAC timing, 4-11
  - polarity
    - configuration, 2-6
    - settings (table), 2-5
  - power-on state, 4-11
  - signal connections, 3-14
  - specifications
    - dynamic characteristics, A-5
    - output characteristics, A-4
    - stability, A-5
    - transfer characteristics, A-4
    - voltage output, A-5
  - theory of operation, 4-10

## B

- bus interface specifications, A-7

## C

- calibration
  - EEPROM storage, 5-1
  - loading calibration constants, 5-1
  - overview, 5-1
- CLK signals
  - general-purpose timing signal connections, 3-27
  - timing requirements signals (figure), 3-31
- CLKB1 signal (table), 3-4
- CLKB2 signal (table), 3-4
- common-mode signal rejection considerations, 3-13
- configuration
  - analog input
    - analog I/O settings (table), 2-3
    - default settings, 2-3
    - exceeding maximum ratings (caution), 2-3
    - input modes, 2-4
    - input polarity, 2-4
  - analog output polarity, 2-6
  - counter/timers, 2-6
  - digital I/O, 2-6
  - PC Card, C-1
    - typical configuration (figure), 2-2
- contacting National Instruments, E-2
- conventions used in the manual, *xi*
- Counter 0 on 82C53(A) counter/timer, 3-22
- Counter 1 on 82C53(A) counter/timer, 3-22
- counter/timers
  - configuration, 2-6
  - theory of operation, 4-3
- customer
  - education, E-1
  - technical support, E-1

**D**

DAC OUTPUT UPDATE signal, 3-27

DAC0OUT signal (table), 3-3

DAC1OUT signal (table), 3-3

DACWRT signal, 3-27

DAQ and general-purpose timing signal connections

    DAQ timing connections, 3-22

    general-purpose timing connections, 3-26, 3-27

    pins, 3-22

    power connections, 3-31

DAQ timing connections. *See* data acquisition timing connections

DAQCard-1200

    block diagram, 4-1

    configuration. *See* configuration

    differences among Lab-PC+, DAQPad-1200, and DAQCard-1200, B-1

    installation, 2-1

    optional equipment, 1-4

    overview and features, 1-1

    requirements for getting started, 1-2

    software programming choices

        National Instruments ADE software, 1-4

        NI-DAQ driver software, 1-2

    theory of operation. *See* theory of operation

    unpacking, 1-5

DAQPad-1200, compared with Lab-PC+ and DAQCard-1200, B-1

data acquisition rates

    maximum recommended rates (table), 4-9

    settling time versus gain (table), 4-9

data acquisition timing circuitry

    continuous data acquisition, 4-8

    data acquisition operation, 4-8

    interval data acquisition, 4-8

data acquisition timing connections

*See also* general-purpose timing signal connections

    EXTCONV\* signal, 3-23

    EXTTRIG signal, 3-23

    EXTUPDATE\* signal, 3-26

    multiple-channel interval scanning (figure), 3-26

    pins, 3-22

    posttrigger and pretrigger modes, 3-23

    sample counter, 3-22

    sample-interval counter, 3-22

    waveform generation timing sequence, 3-27

DATA signal (table), 3-18

Developer Zone, E-1

DGND signal (table), 3-3, 3-4

diagnostic resources, E-1

DIFF input

    configuration, 2-4

    definition (table), 2-4

    recommended input configurations (table), 3-7

differential connections

    description, 3-7

    DIFF configuration considerations, 3-7

    floating signal sources, 3-8

    ground-referenced signal sources, 3-10

    when to use, 3-8

digital I/O

    circuitry, 4-12

    configuration, 2-6

    specifications, A-5

digital I/O signal connections

    illustration, 3-16

    pins, 3-15

    port C pin connections, 3-17

    timing specifications, 3-18

        mode 1 input timing, 3-19

        mode 1 output timing, 3-20

        mode 2 bidirectional timing, 3-20



## dynamic characteristics

- analog input specifications, A-3
- analog output specifications, A-5

**E**

EEPROM storage of calibration data, 5-1

equipment, optional, 1-4

event-counting application, 3-28

- with external switch gating (figure), 3-28

EXTCONV\* signal

- description (table), 3-3
- maximum voltage input rating, 3-27
- timing connections, 3-23

EXTTRIG signal

- data acquisition timing, 3-23
- description (table), 3-3
- maximum voltage input rating, 3-27

EXTUPDATE\* signal

- data acquisition timing, 3-26
- description (table), 3-3
- maximum voltage input rating, 3-27
- updating DAC output (figure), 3-27

**F**

floating signal sources

- differential connections, 3-8
- purpose and use, 3-6
- single-ended connections (RSE configuration), 3-11

frequency measurement, 3-29

- general-purpose timing signal connections, 3-29

frequently asked questions, E-1

**G**

GATB0 signal (table), 3-3

GATB1 signal (table), 3-4

GATB2 signal (table), 3-4

GATE signals

- general-purpose timing signal connections, 3-27
- timing requirements signals (figure), 3-31

general-purpose timing signal connections

- See also* data acquisition timing connections

event-counting, 3-28

frequency measurement, 3-29

GATE, CLK, and OUT signals, 3-27

pins, 3-22

pulse generation, 3-28

pulsewidth measurement, 3-29

square wave generation, 3-28

time-lapse measurement, 3-29

- timing requirements for GATE, CLK, and OUT signals (figure), 3-31

ground-referenced signal sources

- differential connections, 3-10
- purpose and use, 3-6
- recommended input configurations (table), 3-7
- single-ended connections (NRSE configuration), 3-12

**H**

help

- technical support, E-1

**I**

I/O connector

- exceeding maximum ratings (caution), 3-1
- pin assignments (figure), 3-2

IBF signal (table), 3-18

input configurations

- differential connection considerations, 3-7

- floating signal sources
  - differential connections, 3-8
  - recommended input configurations (table), 3-7
- ground-referenced signal sources
  - differential connections, 3-10
  - recommended input configurations (table), 3-7

installation, DAQCard-1200, 2-1

instrumentation amplifier, 3-5

interval scanning data acquisition
 

- multiple-channel interval scanning (figure), 3-25

INTR signal (table), 3-18

## L

Lab-PC+, compared with DAQPad-1200 and DAQCard-1200, B-1

## M

mode 1 input timing, 3-19

mode 1 output timing, 3-20

mode 2 bidirectional timing, 3-20

## N

National Instruments

- Alliance Program, E-1

- customer education, E-1

- Developer Zone, E-1

- system integration services, E-1

- technical support, E-1

- Web support, E-1

- worldwide offices, E-2

National Instruments documentation, *xii*

NI Developer Zone, E-1

NI-DAQ driver software, 1-2

NRSE input

- configuration, 2-5

- definition (table), 2-4

- recommended input configurations (table), 3-7

- single-ended connections for ground-referenced signal sources, 3-12

## O

OBFF\* signal (table), 3-18

online technical support, E-1

operation of DAQCard-1200. *See* theory of operation

optional equipment, 1-4

OUT signals

- general-purpose timing signal connections, 3-27

- timing requirements signals (figure), 3-31

OUTB0 signal (table), 3-3

OUTB1 signal

- DAQ timing connections, 3-25

- description (table), 3-3

- maximum voltage input rating, 3-27

OUTB2 signal (table), 3-4

## P

PA<0..7> signal

- description (table), 3-3

- digital I/O signal connections, 3-15

PB<0..7> signal

- description (table), 3-3

- digital I/O signal connections, 3-15

PC Card

- I/O channel interface circuitry

- block diagram (figure), 4-2

- theory of operation, 4-3

PC<0..7> signal

- description (table), 3-3

- digital I/O signal connections, 3-15

- physical specifications, A-7
- pin assignments for I/O connector (figure), 3-2
- polarity
  - analog input, 2-4
  - analog output, 2-6
  - bipolar and unipolar signal range versus gain (table), 3-5
- port C signal assignments (table), 3-17
- posttrigger mode, 3-23
- power connections, 3-31
- power requirement specifications, A-7
- power-on state, 4-11
- pretrigger mode, 3-24
- pulse generation, 3-28
- pulsewidth measurement, 3-29

## R

- RD\* signal (table), 3-18
- referenced single-ended mode. *See* RSE input
- requirements for getting started, 1-2
- RSE input
  - configuration, 2-5
  - definition (table), 2-4
  - recommended input configurations (table), 3-7
  - single-ended connections for floating signal sources, 3-11

## S

- sample counter, 3-22
- sample-interval counter, 3-22
- sampling rate (note), 4-10
- signal connections
  - analog input signal connections
    - bipolar and unipolar signal range versus gain (table), 3-5
    - common-mode signal rejection, 3-13

- differential connections
  - floating signal sources, 3-8
  - grounded signal sources, 3-10
  - single-ended connections, 3-11
  - when to use, 3-8
- exceeding maximum input voltage ratings (caution), 3-4
- floating signal sources, 3-6
- ground-referenced signal sources, 3-6
- input configurations, 3-7
- instrumentation amplifier, 3-5
- pins, 3-4
- recommended input configurations (table), 3-7
- single-ended connections
  - floating signal sources (RSE configuration), 3-11
  - grounded signal sources (NRSE configuration), 3-12
  - when to use, 3-11
  - types of signal sources, 3-6
- analog output signal connections, 3-14
- DAQ and general-purpose timing signal connections
  - data acquisition timing connections, 3-22
  - general-purpose timing connections, 3-26, 3-27
  - pins, 3-22
  - power connections, 3-31
- digital I/O signal connections
  - illustration, 3-16
  - pins, 3-15
  - port C pin connections, 3-17
  - timing specifications
    - mode 1 input timing, 3-19
    - mode 1 output timing, 3-20
    - mode 2 bidirectional timing, 3-20

- I/O connector
  - exceeding maximum ratings (caution), 3-1
  - pin assignments (figure), 3-2
  - signal descriptions (table), 3-3
- signal descriptions, 3-3
- single-ended connections
  - floating signal sources (RSE configuration), 3-11
  - ground-referenced signal sources (NRSE configuration), 3-12
  - when to use, 3-11
- software programming choices
  - National Instruments ADE software, 1-4
  - NI-DAQ driver software, 1-2
- specifications
  - analog input
    - amplifier characteristics, A-2
    - dynamic characteristics, A-3
    - input characteristics, A-1
    - stability, A-4
    - transfer characteristics, A-2
  - analog output
    - dynamic characteristics, A-5
    - output characteristics, A-4
    - stability, A-5
    - transfer characteristics, A-4
    - voltage output, A-5
  - bus interface, A-7
  - digital I/O, A-5
  - physical, A-7
  - power requirements, A-7
  - timing I/O, A-6
- square wave generation, 3-28
- stability
  - analog input specifications, A-4
  - analog output specifications, A-5
- STB\* signal (table), 3-18
- system integration, by National Instruments, E-1

## T

- technical support resources, E-1
- telephone technical support, E-2
- theory of operation
  - analog input
    - circuitry, 4-6
    - data acquisition rates, 4-9
    - data acquisition timing, 4-8
  - analog output
    - circuitry, 4-10
    - DAC timing, 4-11
    - power-on state, 4-11
  - block diagram of DAQCard-1200, 4-1
  - digital I/O, 4-12
  - functional overview, 4-1
  - PC card I/O channel interface
    - circuitry, 4-2
    - timing, 4-3
- time-lapse measurement, 3-29
- timing circuitry
  - illustration, 4-4
  - theory of operation, 4-3
- timing I/O specifications, A-6
- timing signal connections. *See* data acquisition timing connections; general-purpose timing signal connections
- timing specifications, digital I/O
  - mode 1 input timing, 3-19
  - mode 1 output timing, 3-20
  - mode 2 bidirectional timing, 3-20
- training, customer, E-1
- transfer characteristics
  - analog input specifications, A-2
  - analog output specifications, A-4
- troubleshooting resources, E-1

## **U**

unpacking the DAQCard-1200, 1-5

## **V**

voltage output specifications, A-5

## **W**

Web support from National Instruments, E-1

worldwide technical support, E-2

WRT\* signal (table), 3-18