

COMPREHENSIVE SERVICES

We offer competitive repair and calibration services, as well as easily accessible documentation and free downloadable resources.

SELL YOUR SURPLUS

We buy new, used, decommissioned, and surplus parts from every NI series. We work out the best solution to suit your individual needs.

 Sell For Cash  Get Credit  Receive a Trade-In Deal

OBSOLETE NI HARDWARE IN STOCK & READY TO SHIP

We stock **New**, **New Surplus**, **Refurbished**, and **Reconditioned** NI Hardware.



Bridging the gap between the manufacturer and your legacy test system.

 1-800-915-6216

 www.apexwaves.com

 sales@apexwaves.com

All trademarks, brands, and brand names are the property of their respective owners.

Request a Quote

 **CLICK HERE**

FP-1001

FP-1000

FieldPoint RS-232 Network Module



Highlights

- RS-232 interface to host computer
- Built-in isolated RS-485 repeater to connect to FP-1001 network modules
- Compatible with industry standard Optomux protocol
- Runs on 11 to 30 VDC power
- Built-in high efficiency power supply powers I/O modules
- -40° to +70° C operation

Overview

The FP-1000 is a network module for the FieldPoint system. It provides connection to an RS-232 network using a simple ASCII protocol. In addition, it has an isolated RS-485 repeater built in to transparently add up to 24 FP-1001 network modules to the same host computer serial port.

This document provides a quick guide to installing and configuring the FP-1000 network module. For more detailed information on using the network module, refer to the FP-1000/1001 user manual. For information on the ASCII protocol used by the network module, refer to the FP-1000/1001 programmer reference manual.

DIN Rail Mounting



NOTE: *Terminal bases must be connected to the network module before applying power to the module. Do not connect or disconnect terminal bases while power is applied to the network module.*

The FP-1000 has a simple rail clip for mounting reliably onto a standard 35 mm DIN rail. To install the FP-1000 to the DIN rail, follow these steps:

1. With a flat bladed screwdriver, open the rail clip to the unlocked position as shown in Figure 1.

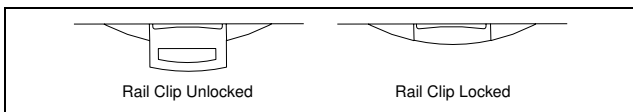

Figure 1. DIN Rail Clip

2. Hook the lip on the rear of the FP-1000 onto the top of a 35 mm DIN rail and press the FP-1000 down onto the DIN rail as shown in Figure 2.

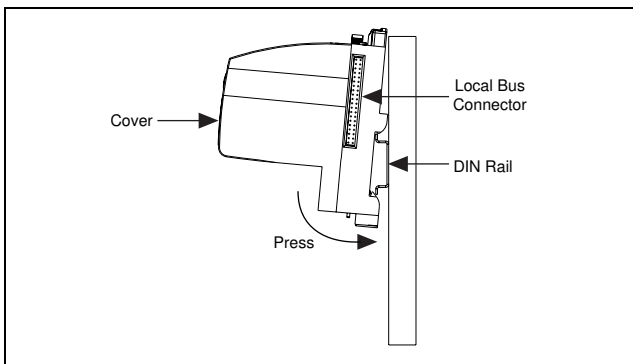

Figure 2. Installing the Network Module onto a DIN Rail

3. Slide the FP-1000 to the desired position along the DIN rail. After the FP-1000 is in position, lock it to the DIN rail by pushing the rail clip in.

4. Add terminal bases to the DIN rail with their local bus connectors firmly mated to the FP-1000 local bus connector. The FP-1000 is shipped with a protective cover over the local bus connector. Remove this protective cover, and place it over the local bus connector of the last terminal base in the stack. Figure 3 shows an installed FP-1000 network module.

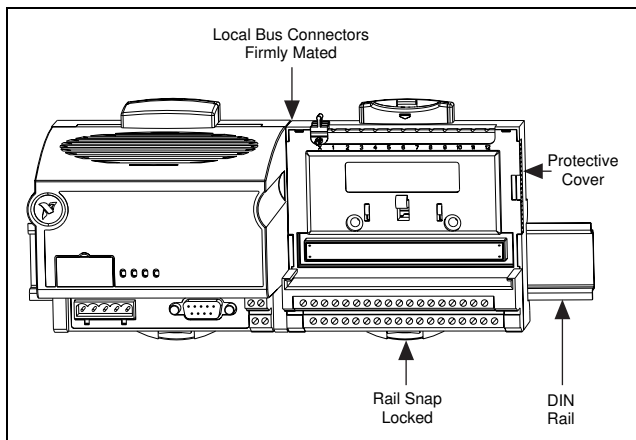

Figure 3. Installed Network Module

Network Connection

Connect the FP-1000 to a host computer using the 9-position DSub RS-232 connector on the FP-1000. Connect the RS-232 port of the FP-1000 to the RS-232 port on your computer using a male-to-female “straight-through” cable. Do not use a “null modem” cable (usually female-to-female). For reference, the pinout of the RS-232 connector on the FP-1000 is shown in Figure 4.

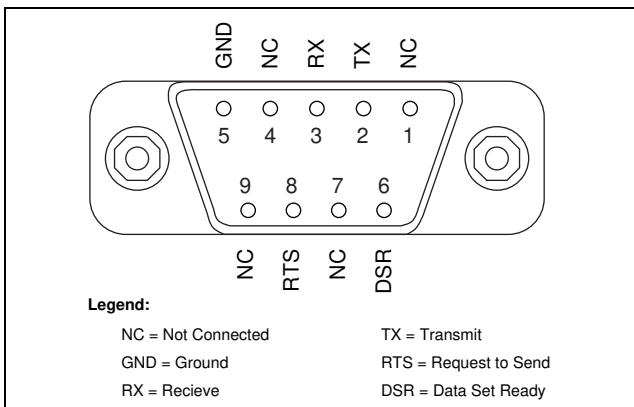

Figure 4. RS-232 Connector Pinout

Up to 24 additional FP-1001 network modules can be connected to this FP-1000 module by using the built in RS-485 repeater. This repeater makes the RS-485 port of the FP-1000 appear to the additional FP-1001 modules as if it were an RS-485 port of the host computer. The pinout of the RS-485 connector is shown in Figure 5.

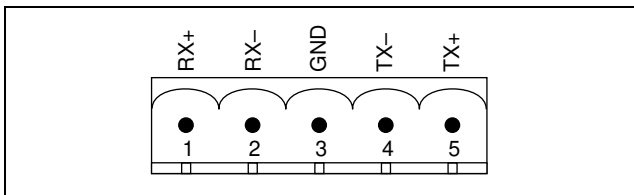

Figure 5. RS-485 Connector Pinout

The TX+ of the FP-1000 must be connected to the RX+ of all of the FP-1001 modules, and the TX- of the FP-1000 must be connected to the RX- of all of the FP-1001 modules. This pair of connections provides communication from the host computer, through the FP-1000, to the FP-1001 modules.

The RX+ of the FP-1000 must be connected to the TX+ of all of the FP-1001 modules, and the RX- of the FP-1000 must be connected to the TX- of all of the FP-1001 modules. This pair of connections provides communication to the host computer, through the FP-1000, from the FP-1001 modules.

These connections are shown in Figure 6.

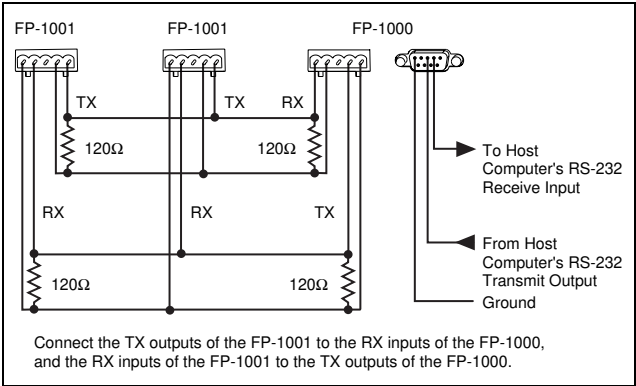

Figure 6. Typical Signal Connections with One FP-1000 Connected to Multiple FP-1001 Network Modules

Figure 6 also shows the use of 120 Ohm termination resistors. An RS-485 network must be terminated at each end of the network, but not anywhere else. Termination resistors should be installed between the RX pair and between the TX pair of the FP-1000 RS-485 port. Termination resistors should also be installed on the RS-485 port of the last FP-1001 on the network. A pair of terminating resistors are provided with each network module. To install them, twist the resistor leads with the RS-485 signal wires and insert them into the RS-485 port terminals.

Setting the Address and Baud Rate

Figure 7 shows the 8-position switch on the FP-1000 network module. Switches 1-5 set the network address, and switches 6-8 set the baud rate. Every network module connected to one serial port of the host computer must be given a unique address, however modules on different serial ports may have the same address. Every module on one serial port of the host computer must have the same baud rate.

Switches 1-5 set the network address of the FP-1000. The addresses of the terminal bases connected to the network module are automatically configured to be sequentially higher than the network module's address. For example, if the network module is set to address 20, the I/O module in the terminal base immediately connected the network module is at address 21, the next I/O

module is at address 22, and so on. A terminal base is assigned a network address whether an I/O module is inserted into it or not.

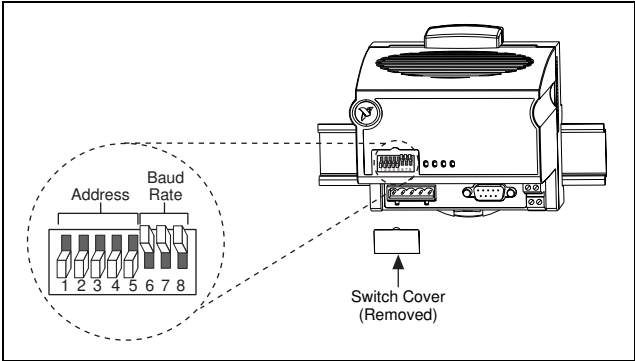



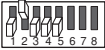







Figure 7. Address and Baud Rate Switch

Table 1 shows the possible switch positions and the corresponding address of the FP-1000.

Table 1. Network Address Switch Settings









Switch Positions 1-5	Network Module Address (Decimal)	Switch Positions 1-5	Network Module Address (Decimal)
	0		130
	10		140
	20		150
	30		160
	40		170
	50		180
	60		190

Table 1. Network Address Switch Settings (Continued)

Switch Positions 1-5	Network Module Address (Decimal)	Switch Positions 1-5	Network Module Address (Decimal)
	70		200
	80		210
	90		220
	100		230
	110		240
	120	Other Settings	Not Allowed

Switches 6-8 set the baud rate of the FP-1000. Table 2 shows the switch positions and the corresponding network baud rates.

Table 2. Baud Rate Switch Settings

Switch Positions 6-8	Network Module Baud Rate	Switch Positions 6-8	Network Module Baud Rate
	300		19200
	1200		38400
	2400		57600
	9600		115200

Powering the FP-1000



NOTE: *Terminal bases must be connected to the FP-1000, and the baud rate switch must be set, before power is applied to the FP-1000.*

An 11-30 VDC power supply is required by each FieldPoint stack. The network module filters and regulates this supplied power and provides power for all the I/O modules in the stack. Therefore you need not provide power separately to each FieldPoint I/O module in the stack. If your field I/O device needs to be powered separately, you can use the terminals provided on each terminal base for such power supply connections.

The power connector is a 4-pin screw terminal connector whose pinout is shown in Figure 8.

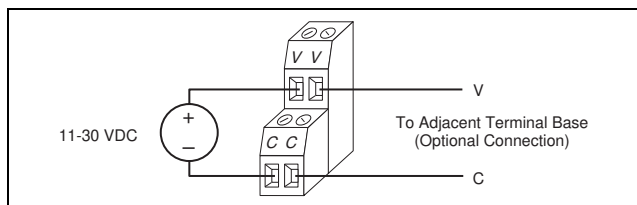

Figure 8. FP-1000 and FP-1001 Power Connector Pinout

The two terminals labeled V are internally connected on the network module, as are the two terminals labeled C. Power must be applied to one V and C pair for operation of the FieldPoint system. If you want to power your field I/O devices from the same power supply, the second V and C pair provides a convenient means of connecting power to the V and C terminals of a terminal base. Figure 8 shows this optional connection.

Specifications

Network ports	1 RS-232 port, 1 RS-485 repeater port
Baud Rates	300, 1200, 2400, 9600, 19200, 38400, 57600, 115200 (switch selectable)
Communication parameters	1 start bit, 8 data bits, 1 stop bit, No parity
RS-485 isolation	2500 Vrms breakdown, 250 Vrms operational
Power Consumption.....	1 W + 1.15 * \sum (I/O module power requirements)
Operating Temperature	-40° C to +70° C
Storage Temperature.....	-55° C to +100° C
Relative Humidity.....	5% to 90% non-condensing
Weight.....	250 g (8.7 oz.)

CE Mark Compliance

This product meets applicable EU directive(s) as follows:

Safety isolation

EN 61010 (double insulation for 250 Vrms working isolation, installation category II)

EMC Directive

Immunity	EN 50082-1:1994
Emissions	EN 55011:1991 Group I Class A at 10 meters

Mechanical Dimensions

Figure 9 shows the mechanical dimensions of the FP-1000.

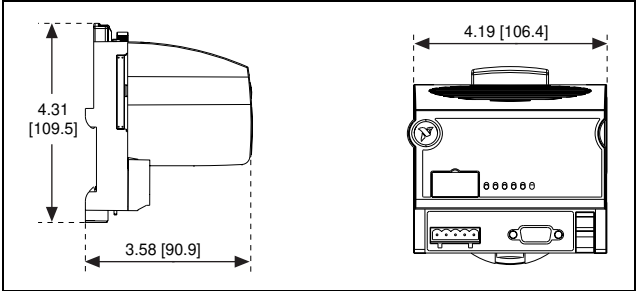

Figure 9. Mechanical Dimensions



321697A-01

Jul97