

COMPREHENSIVE SERVICES

We offer competitive repair and calibration services, as well as easily accessible documentation and free downloadable resources.

SELL YOUR SURPLUS

We buy new, used, decommissioned, and surplus parts from every NI series. We work out the best solution to suit your individual needs.

 Sell For Cash  Get Credit  Receive a Trade-In Deal

OBSOLETE NI HARDWARE IN STOCK & READY TO SHIP

We stock **New**, **New Surplus**, **Refurbished**, and **Reconditioned** NI Hardware.



Bridging the gap between the manufacturer and your legacy test system.

 1-800-915-6216

 www.apexwaves.com

 sales@apexwaves.com

All trademarks, brands, and brand names are the property of their respective owners.

Request a Quote

 **CLICK HERE**

FP-2000

FP-PS-4

FieldPoint Power Supply



These operating instructions describe the installation, features, and characteristics of the FP-PS-4.

Features

The FP-PS-4 is a FieldPoint power supply module with the following features:

- 24 VDC output
- Convenient DIN rail mounting or optional panel mounting
- Universal AC power input: 90 to 264 VAC, 47 to 63 Hz
- Modular FieldPoint form factor for easy integration with other FieldPoint modules
- 15 W output for 0 to 50 °C operation

Installation

You can mount your FieldPoint system either to a DIN rail or directly on a panel. The following sections give instructions for both mounting methods.

Mounting Your FP-PS-4 on a DIN Rail

The FP-PS-4 power supply module has a simple rail clip for reliable mounting onto a standard 35 mm DIN rail. Follow these steps to mount the module on a DIN rail.

1. Use a flat-bladed screwdriver to unlock the DIN rail clip, as shown in Figure 1.

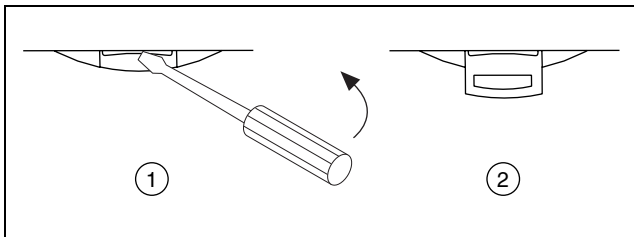

1 Rail clip locked

2 Rail clip unlocked

Figure 1. Unlocking the Rail Clip

2. Attach the lip on the rear of the FP-PS-4 onto the top of a 35 mm DIN rail and press it down onto the DIN rail, as shown in Figure 2.

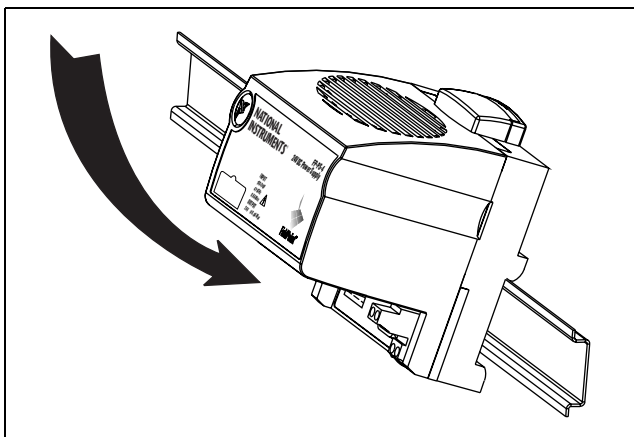

Figure 2. Attaching the Module to a DIN Rail

- Slide the FP-PS-4 to the desired position along the DIN rail. For maximum cooling, leave a 25 mm (1.0 in.) space between the FP-PS-4 and other devices on your DIN rail. After it is in position, lock it to the DIN rail by pushing the rail clip to the locked position, as shown in Figure 3.

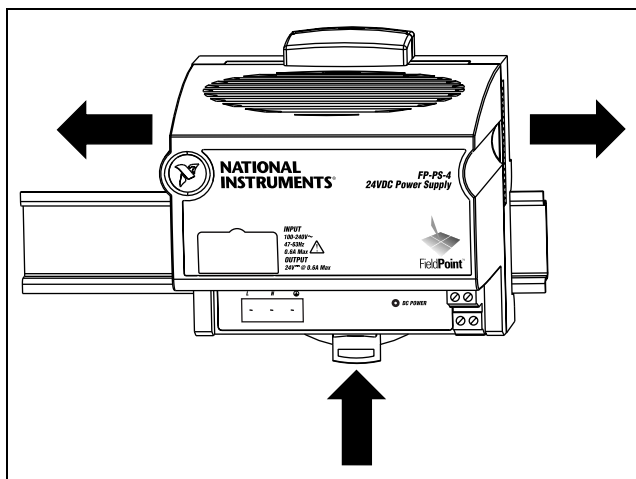

Figure 3. Positioning and Locking Your Module

Mounting Your FP-PS-4 on a Panel

Follow these steps to install the optional FieldPoint network panel mount accessory and mount the FP-PS-4 power supply module to a panel. You can order the panel mount accessory, part number 777609-01, from National Instruments.

1. Use a flat-bladed screwdriver to unlock the rail clip, as shown in Figure 1.
2. Attach the panel mount accessory to the module, as shown in Figure 4.

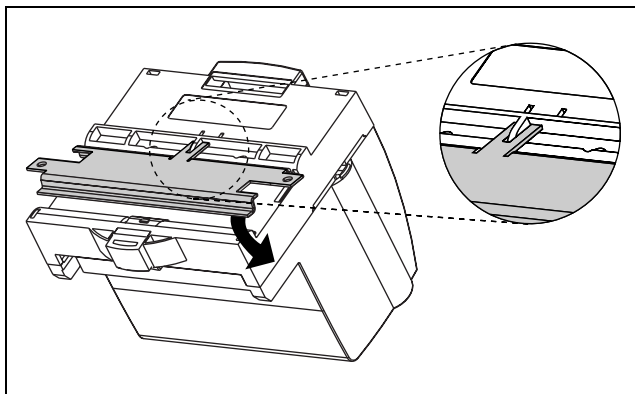

Figure 4. Installing the Panel Mount Accessory

3. Lock the panel mount accessory into place by pushing the rail clip to the locked position.

4. Mount the FP-PS-4 to your panel with the panel mount accessory, as shown in Figure 5. The installation guide that comes with the panel mount accessory includes a template that you can use to drill pilot holes for mounting FieldPoint modules. For maximum cooling, leave a 25 mm (1.0 in.) space between the FP-PS-4 and other devices.

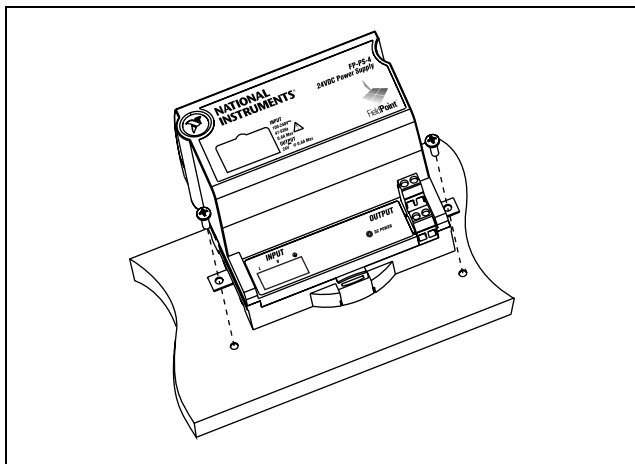

Figure 5. Connecting Your FP-PS-4 to the Panel

Connecting Power to Your FieldPoint System



Caution Before you connect the FP-PS-4 to your FieldPoint system, make sure the power cord is not plugged into an electrical outlet.

Each FP-PS-4 provides a 24 VDC output. You decide the number of FP-PS-4 modules you need in your bank based upon the specific power and isolation requirements. The total power of all of the FieldPoint modules and other devices connected to an FP-PS-4 cannot exceed the specified output for the temperature range at which you are using FP-PS-4. For FieldPoint power requirement details, refer to the operating instructions for your particular I/O modules. Decide how you want to power your FieldPoint bank based on the power requirements of your bank and your isolation

needs. Select one or a combination of the methods to power the signals of each of your I/O modules:

- The signals of the I/O module are powered by an FP-PS-4 that is connected to only that I/O module.
- The signals of the I/O module share an FP-PS-4 with a neighboring I/O module or network module. This is called *cascading power*.



Caution Cascading power from neighboring bases or network modules defeats isolation between cascaded modules.

Figure 6 shows a combination of the two ways to power the FieldPoint bank.

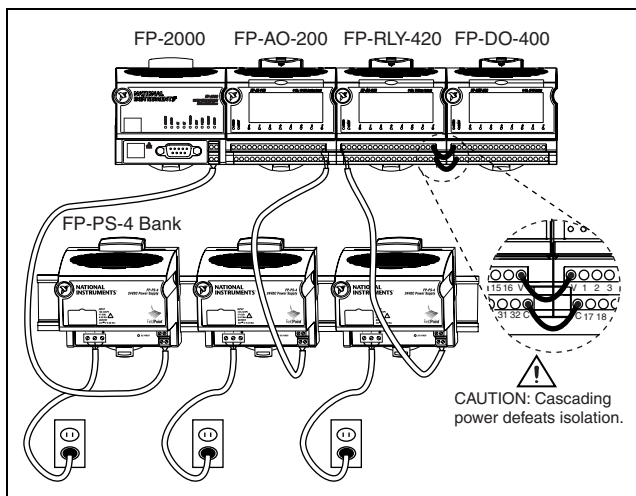

Figure 6. Wiring Power to Your FieldPoint Bank

In Figure 6, the FP-PS-4 bank provides the power using both of the methods mentioned previously. The FP-2000 and FP-AO-200 have their own power supplies. Isolation is maintained because the FP-AO-200 has its own power supply. The FP-RLY-420 and FP-DO-400 share a power supply, which provides enough power, but defeats isolation between the signals of those two modules.

Ensure that all the wiring is installed according to local codes and regulations by qualified electrical personnel. Follow these steps to connect the FP-PS-4 to your FieldPoint system.

1. Use a 16 to 26 AWG stranded wire to connect the FP-PS-4 to your FieldPoint network module or I/O module. Connect the positive wire to the V terminal and the negative wire to the C terminal of the FP-PS-4.
2. Connect the other ends of the wires to the V and C terminals of the FieldPoint network module or I/O module.
3. Ensure that the plug-in AC input terminal connector is plugged into the input port on the FP-PS-4.



Note Be careful to install the correct conductor in the appropriate terminal. The color of the conductor wires varies depending on North American versus international standards as described in Figure 7. The wires are drawn to scale according to the 7 mm (0.275 in.) strip length requirement.

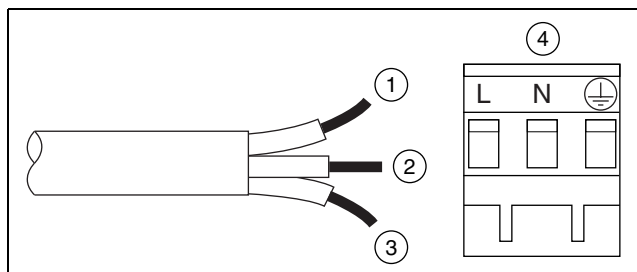

- 1 Line wire (black by North American standards; brown by international standards)
- 2 Neutral wire (white by North American standards; blue by international standards)
- 3 Ground wire (green by North American standards; green/yellow by international standards)
- 4 Plug-in AC input terminal connector

Figure 7. Conductor Wire Color Standards for the Plug-in AC Input Terminal Connector

4. Connect the black or brown conductor into the line terminal labeled L.
5. Connect the white or blue conductor into the neutral terminal labeled N.

- Connect the green or green/yellow conductor into the ground terminal.



Caution When you install the conductors, make sure that the entire conductor is in the screw terminal and that there are no loose strands outside of the terminal. Only install one wire in each terminal.

Specifications

The following specifications are typical for a range of 0 to 60 °C, unless otherwise noted.

Installation

Terminal wiring 16-26 AWG copper conductor wire with 7 mm (0.275 in.) strip length as shown in Figure 8

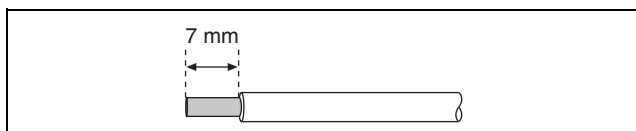

Figure 8. Conductor Wire with the Correct Strip Length (drawing is to scale)

Torque for screw terminals 0.5-0.6 Nm (4.4–5.3 in.-lbs)

Input Characteristics

Input voltage 90–264 VAC
Frequency 47–63 Hz, single phase
Maximum current consumption..... 0.6 A at 120 VAC, 60 Hz
Input protection..... Nonreplaceable internal AC fuse

Output Characteristics

Output voltage 24 VDC, nonadjusting
Nominal current (I_N) 600 mA
Nominal continuous power
 0 to 50 °C 15 W
 50 to 60 °C 10 W

Overload protection Protected against short circuits and output overload

Physical

Indicator Green DC POWER LED

Weight 300 g (10.5 oz)

Environmental

FieldPoint modules are intended for indoor use only.

Operating temperature

15 W operation 0 to 50 °C

10 W operation 50 to 60 °C

Storage temperature -40 to +85 °C

Humidity 10 to 90% RH,
noncondensing

Maximum altitude 2,000 m

Pollution degree 2

Safety

Do *not* operate FieldPoint products in an explosive atmosphere or where there may be flammable gases or fumes. If you need to operate FieldPoint products in such an environment, the FieldPoint products *must* be in a suitably rated enclosure. The FP-PS-4 meets the requirements of the following standards for safety and electrical equipment for measurement, control, and laboratory use:

- EN 61010-1:1993/A2:1995, IEC 61010-1:1990/A2:1995
- UL 3121-1:1998
- CAN/CSA C22.2 no. 1010.1:1992/A2:1997

Electromagnetic Compatibility

CE, C-Tick and FCC Part 15 (Class A) Compliant

Electrical emissions EN 55011 Class A at 10 m
FCC Part 15A above 1 GHz

Electrical immunity Evaluated to EN 61326:
1997/A1: 1998, Table 1



Note For full EMC compliance, you must operate this device with shielded cabling. See the Declaration of Conformity (DoC) for this product for any additional

regulatory compliance information. To obtain the DoC for this product, click **Declaration of Conformity** at ni.com/hardref.nsf/.

Mechanical Dimensions

Figure 9 shows the mechanical dimensions of the FP-PS-4. Dimensions are given in millimeters [inches].

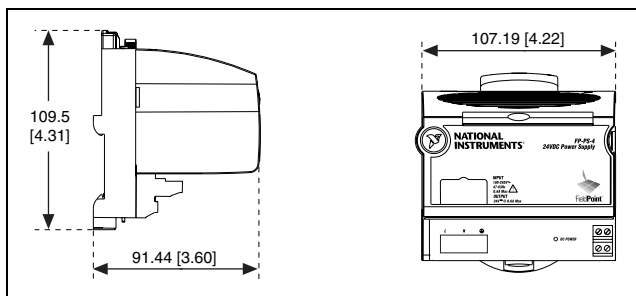

Figure 9. Mechanical Dimensions

Where to Go for Support

For more information about setting up your FieldPoint system, refer to these National Instruments documents:

- Your FieldPoint network module user manual
- Your other FieldPoint I/O module operating instructions
- Your FieldPoint terminal base operating instructions

Go to ni.com/support for the most current manuals, examples, and troubleshooting information.

For telephone support in the United States, create your service request at ni.com/ask and follow the calling instructions or dial 512 795 8248. For telephone support outside the United States, contact your local branch office:

Australia 03 9879 5166, Austria 0662 45 79 90 0,
Belgium 02 757 00 20, Brazil 011 284 5011,
Canada (Calgary) 403 274 9391, Canada (Montreal) 514 288 5722,
Canada (Ottawa) 613 233 5949, Canada (Québec) 514 694 8521,
Canada (Toronto) 905 785 0085, China (Shanghai) 021 6555 7838,
China (ShenZhen) 0755 3904939, Czech Republic 02 2423 5774,
Denmark 45 76 26 00, Finland 09 725 725 11, France 01 48 14 24 24,
Germany 089 741 31 30, Greece 30 1 42 96 427,
Hong Kong 2645 3186, India 91805275406,
Israel 03 6120092, Italy 02 413091, Japan 03 5472 2970,
Korea 02 596 7456, Malaysia 603 9596711,
Mexico 001 800 010 0793, Netherlands 0348 433466,
New Zealand 09 914 0488, Norway 32 27 73 00,
Poland 0 22 528 94 06, Portugal 351 1 726 9011,
Russia 095 2387139, Singapore 2265886, Slovenia 386 3 425 4200,
South Africa 11 805 8197, Spain 91 640 0085,
Sweden 08 587 895 00, Switzerland 056 200 51 51,
Taiwan 02 2528 7227, United Kingdom 01635 523545