

COMPREHENSIVE SERVICES

We offer competitive repair and calibration services, as well as easily accessible documentation and free downloadable resources.

SELL YOUR SURPLUS

We buy new, used, decommissioned, and surplus parts from every NI series. We work out the best solution to suit your individual needs.

 Sell For Cash  Get Credit  Receive a Trade-In Deal

OBSOLETE NI HARDWARE IN STOCK & READY TO SHIP

We stock **New**, **New Surplus**, **Refurbished**, and **Reconditioned** NI Hardware.



Bridging the gap between the manufacturer and your legacy test system.

 1-800-915-6216

 www.apexwaves.com

 sales@apexwaves.com

All trademarks, brands, and brand names are the property of their respective owners.

Request a Quote

 **CLICK HERE**

FP-AI-100

FieldPoint™ Operating Instructions

FP-AI-100 and cFP-AI-100

Eight-Channel, 12-Bit Analog Input Modules

These operating instructions describe how to install and use the FP-AI-100 and cFP-AI-100 analog input modules (referred to inclusively as the [c]FP-AI-100). For information about configuring and accessing the [c]FP-AI-100 over a network, refer to the user manual for the FieldPoint network module you are using.

Features

The [c]FP-AI-100 is a FieldPoint analog input module with the following features:

- Eight analog voltage or current input channels
- 11 input ranges: 0–1 V, 0–5 V, 0–15 V, 0–30 V, ± 1 V, ± 5 V, ± 15 V, ± 30 V, 0–20 mA, 4–20 mA, and ± 20 mA
- 12-bit resolution
- 250 V_{rms} CAT II continuous channel-to-ground isolation, verified by 2,300 V_{rms}, 1 minute dielectric withstand test
- –40 to 70 °C operation
- Hot swappable

Installing the FP-AI-100

The FP-AI-100 mounts on a FieldPoint terminal base (FP-TB-*x*), which provides operating power to the module. Installing the FP-AI-100 onto a powered terminal base does not disrupt the operation of the FieldPoint bank.

To install the FP-AI-100, refer to Figure 1 and complete the following steps:

1. Slide the terminal base key to either position X (used for any module) or position 1 (used for the FP-AI-100).
2. Align the FP-AI-100 alignment slots with the guide rails on the terminal base.
3. Press firmly to seat the FP-AI-100 on the terminal base. When the FP-AI-100 is firmly seated, the latch on the terminal base locks it into place.

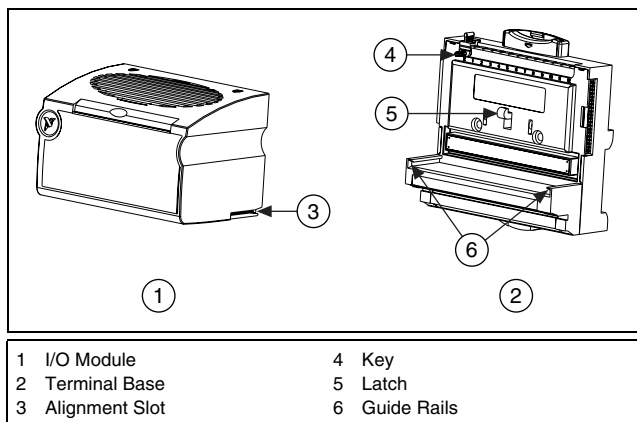

Figure 1. Installing the FP-AI-100

Installing the cFP-AI-100

The cFP-AI-100 mounts on a Compact FieldPoint backplane (cFP-BP-*x*), which provides operating power to the module. Installing the cFP-AI-100 onto a powered backplane does not disrupt the operation of the FieldPoint bank.

To install the cFP-AI-100, refer to Figure 2 and complete the following steps:

1. Align the captive screws on the cFP-AI-100 with the holes on the backplane. The alignment keys on the cFP-AI-100 prevent backward insertion.
2. Press firmly to seat the cFP-AI-100 on the backplane.

- Using a number 2 Phillips screwdriver with a shank of at least 64 mm (2.5 in.) length, tighten the captive screws to 1.1 N · m (10 lb · in.) of torque. The nylon coating on the screws prevents them from loosening.

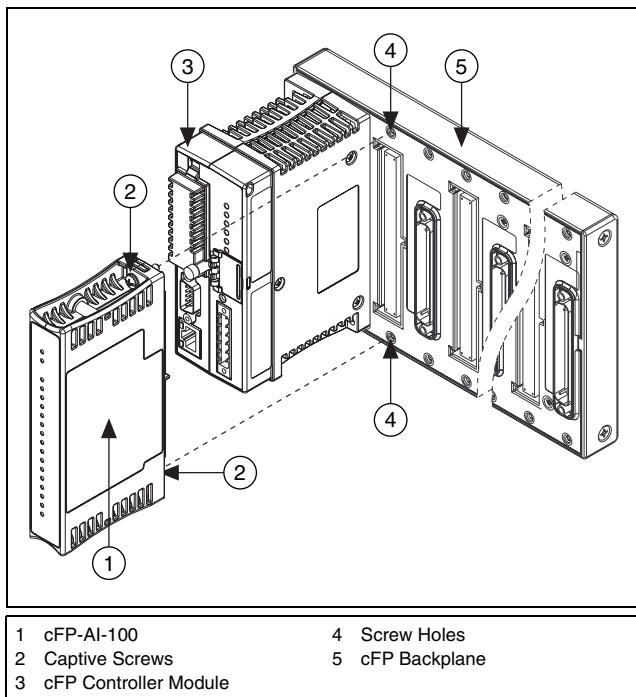

Figure 2. Installing the cFP-AI-100

Wiring the [c]FP-AI-100

The FP-TB-*x* terminal base has connections for each of the eight input channels and for an optional external supply to power field devices. The cFP-CB-*x* connector block provides the same connections.

Table 1 lists the terminal assignments for the signals associated with each channel. The terminal assignments are the same for the FP-TB-*x* terminal bases and the cFP-CB-*x* connector blocks.

Table 1. Terminal Assignments

Channel	Terminal Numbers			
	V_{in}	I_{in}	V_{sup}	COM
0	1	2	17	18
1	3	4	19	20
2	5	6	21	22
3	7	8	23	24
4	9	10	25	26
5	11	12	27	28
6	13	14	29	30
7	15	16	31	32

Each channel has separate input terminals for voltage (V_{in}) and current (I_{in}) input. Voltage and current inputs are referenced to the COM terminals. If you are using an external supply to power field devices, connect the power supply to the V and C terminals of the terminal base or connector block. Refer to the sections that follow for detailed wiring diagrams.



Caution Do *not* connect both current and voltage inputs to the same channel.



Caution Cascading power between two modules defeats isolation between those modules. Cascading power from the network module defeats all isolation between modules in the FieldPoint bank.

Taking Measurements with the [c]FP-AI-100

The [c]FP-AI-100 has eight single-ended input channels. All eight channels share a common ground reference that is isolated from other modules in the FieldPoint system. Figure 3 shows the analog input circuitry on one channel.

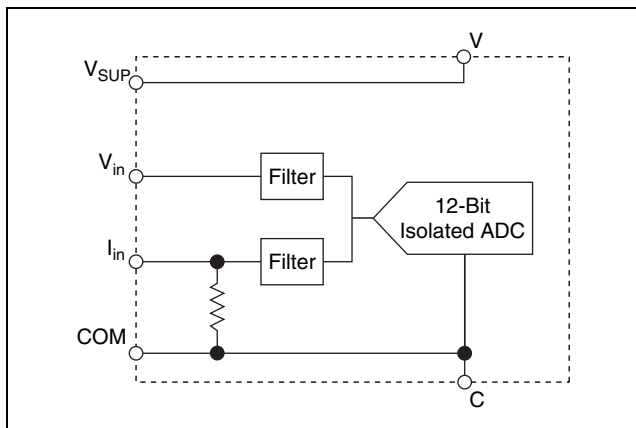

Figure 3. [c]FP-AI-100 Analog Input Circuit, One Channel

Measuring Voltage with the [c]FP-AI-100

The input ranges for voltage signals are 0–1 V, 0–5 V, 0–15 V, 0–30 V, ± 1 V, ± 5 V, ± 15 V, and ± 30 V.

Figure 4 shows how to connect a voltage source without an external power supply to one channel of the [c]FP-AI-100.

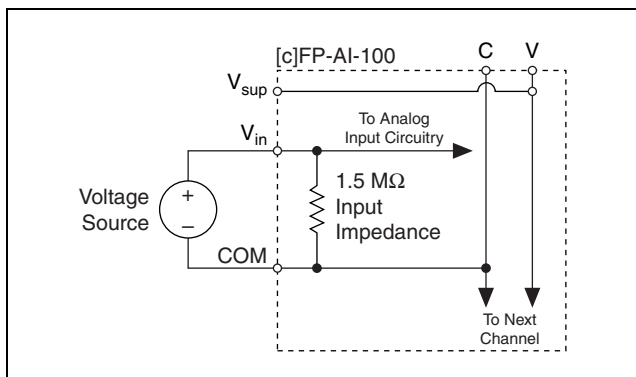

Figure 4. Voltage Source without External Power Supply

Figure 5 shows how to connect a voltage source with an external power supply to one channel of the [c]FP-AI-100.

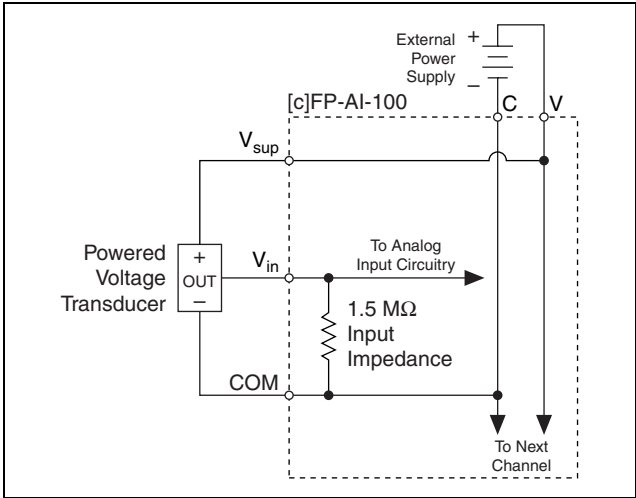

Figure 5. Voltage Source with External Power Supply

Measuring Current with the [c]FP-AI-100

The input ranges for current sources are 0–20, 4–20, and ± 20 mA. The module reads current flowing into the I_{in} terminal as positive and current flowing out of the terminal as negative. Current flows into the I_{in} terminal, goes through a $100\ \Omega$ resistor, and flows out from the COM or C terminal.

Figure 6 shows how to connect a current source without an external power supply to one channel of the [c]FP-AI-100.

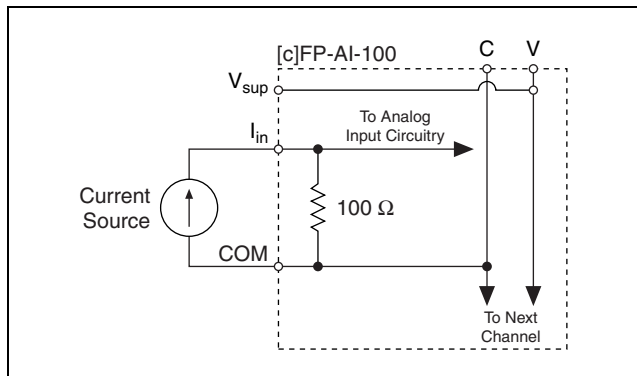

Figure 6. Current Source without External Power Supply

Figure 7 shows how to connect a current source with an external power supply to one channel of the [c]FP-AI-100.

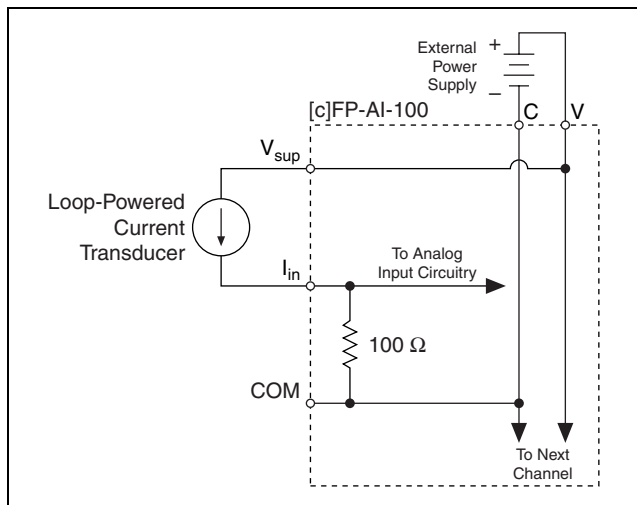

Figure 7. Current Source with External Power Supply

Input Ranges

To prevent inaccurate readings, choose an input range such that the signal you are measuring does not exceed either end of the range. If a channel is not in use, short the positive input to ground and configure the channel for a bipolar input range. Small fluctuations in floating input signals can cause the red **Out of Range** status LED on the module to light if the channel is configured for a unipolar range. Similarly, if a channel is configured for 4–25 mA input and the input current is 0 mA, the channel is always out of range.

Overranging

The [c]FP-AI-100 has an overranging feature that measures a little beyond the nominal values of each range. For example, the actual measurement limit of the ± 5 V range is ± 6.0 V. The overranging feature allows the [c]FP-AI-100 to compensate for field devices with span errors of up to +20% of full scale. Also, with the overranging feature, a noisy signal near full scale does not create rectification errors.

Status Indicators

The [c]FP-AI-100 has two green status LEDs, **POWER** and **READY**. After you insert the [c]FP-AI-100 into a terminal base or backplane and apply power to the connected network module, the green **POWER** indicator lights and the [c]FP-AI-100 informs the network module of its presence. When the network module recognizes the [c]FP-AI-100, it sends initial configuration information to the [c]FP-AI-100. After the [c]FP-AI-100 receives this initial information, the green **READY** indicator lights and the module is in normal operating mode.

In addition to the green **POWER** and **READY** indicators, the [c]FP-AI-100 has one red status LED that lights when the input signal on any channel is outside the configured range. Refer to the *Input Ranges* section for information about selecting input ranges.

Upgrading the FieldPoint Firmware

You may need to upgrade the FieldPoint firmware when you add new I/O modules to the FieldPoint system. For information on determining which firmware you need and how to upgrade the firmware, go to ni.com/info and enter `fpmatrix`.

Isolation and Safety Guidelines



Caution Read the following information before attempting to connect the [c]FP-AI-100 to any circuits that may contain hazardous voltages.

This section describes the isolation of the [c]FP-AI-100 and its compliance with international safety standards. The field wiring connections are isolated from the backplane and the inter-module communication bus. The isolation barriers in the module provide 250 V_{rms} Installation Category II continuous isolation, verified by 2,300 V_{rms}, 1 minute dielectric withstand test. The [c]FP-AI-100 provides *double insulation* (compliant with IEC 61010-1) for working voltages of 250 V_{rms}¹. Safety standards (such as those published by UL and IEC) require the use of double insulation between hazardous voltages and any human-accessible parts or circuits.

Never try to use any isolation product between human-accessible parts (such as DIN rails or monitoring stations) and circuits that can be at hazardous potentials under normal conditions, unless the product is specifically designed for such an application, as is the [c]FP-AI-100.

Even though the [c]FP-AI-100 is designed to handle applications with hazardous potentials, follow these guidelines to ensure a safe total system:

- There is no isolation between channels on the [c]FP-AI-100. If a hazardous voltage is present on any channel, all channels are considered hazardous. Make sure that all other devices and circuits connected to the module are properly insulated from human contact.
- Do *not* share the external supply voltages (the V and C terminals) with other devices (including other FieldPoint devices), unless those devices are isolated from human contact.
- For Compact FieldPoint, you *must* connect the protective earth (PE) ground terminal on the cFP-BP-*x* backplane to the system safety ground. The backplane PE ground terminal has the following symbol stamped beside it: . Connect the

¹ *Working voltage* is defined as the signal voltage plus the common-mode voltage. *Common-mode voltage* is the voltage of the module with respect to ground.

backplane PE ground terminal to the system safety ground using 14 AWG (1.6 mm) wire with a ring lug. Use the 5/16 in. panhead screw shipped with the backplane to secure the ring lug to the backplane PE ground terminal.

- As with any hazardous voltage wiring, make sure that all wiring and connections meet applicable electrical codes and commonsense practices. Mount terminal bases and backplanes in an area, position, or cabinet that prevents accidental or unauthorized access to wiring that carries hazardous voltages.
- Do *not* use the [c]FP-AI-100 as the only isolating barrier between human contact and working voltages higher than 250 V_{rms}.
- Operate the [c]FP-AI-100 only at or below Pollution Degree 2. Pollution Degree 2 means that only nonconductive pollution occurs in most cases. Occasionally, however, a temporary conductivity caused by condensation must be expected.
- Do *not* operate FieldPoint products in an explosive atmosphere or where there may be flammable gases or fumes. If you need to operate FieldPoint products in such an environment, the FieldPoint products *must* be in a suitably rated enclosure.
- Operate the [c]FP-AI-100 at or below Installation Category II. Installation Category II is for measurements performed on circuits directly connected to the low-voltage installation. This category refers to local-level distribution, such as that provided by a standard wall outlet.

Specifications

The following specifications are typical for the range –40 to 70 °C unless otherwise noted. Gain error is calculated as a percentage of input signal value.

Input Characteristics

Number of channels	8
ADC resolution	12 bits
Type of ADC	Successive approximation
Update rate (all channels)	360 Hz (2.8 ms)

Voltage Inputs

The following input signal ranges are software selectable by channel.

Voltage Input Range	Typical Offset Error at 15 to 35 °C	Maximum Offset Error at -40 to 70 °C
0–1 V	2.9 mV	9.3 mV
0–5 V	6.5 mV	17.2 mV
0–15 V	13 mV	30 mV
0–30 V	17.5 mV	33.3 mV
±1 V	3.6 mV	10.3 mV
±5 V	9.5 mV	23 mV
±15 V	21.8 mV	44.7 mV
±30 V	35.1 mV	62.5 mV

Voltage Input Range	With Overranging	Typical Gain Error at 15 to 35 °C (% of Reading)	Maximum Gain Error at -40 to 70 °C (% of Reading)
0–1 V	0–1.2 V	0.065%	0.19%
0–5 V	0–6 V	0.065%	0.19%
0–15 V	0–18 V	0.065%	0.19%
0–30 V	0–36 V	0.065%	0.19%
±1 V	±1.2 V	0.07%	0.22%
±5 V	±6 V	0.07%	0.22%
±15 V	±18 V	0.07%	0.22%
±30 V	±36 V	0.07%	0.22%

Input impedance..... 1.5 MΩ

Effective resolution..... 11.3 bits

Signal input bandwidth..... 170 Hz

Current Inputs

The following input signal ranges are software selectable by channel.

Current Input Range	Typical Offset Error at 15 to 35 °C	Maximum Offset Error at -40 to 70 °C
0–20 mA	12 μ A	20 μ A
4–20 mA	12 μ A	20 μ A
\pm 20 mA	23 μ A	40 μ A

Current Input Range	With Overranging	Typical Gain Error at 15 to 35 °C (% of Reading)	Maximum Gain Error at -40 to 70 °C (% of Reading)
0–20 mA	0–24 mA	0.083%	0.32%
4–20 mA	3.5–24 mA	0.083%	0.32%
\pm 20 mA	\pm 24 mA	0.09%	0.35%

Input impedance..... 100 Ω

Overcurrent protection..... \pm 30 mA

Effective resolution..... 11.5 bits

Signal input bandwidth..... 160 Hz

Physical Characteristics

Indicators Green **POWER** and **READY** indicators; one red **Out of Range** indicator

Weight

FP-AI-100..... 145 g (5.1 oz)

cFP-AI-100..... 115 g (4.0 oz)

Power Requirement

Power from network module 400 mW

Isolation Voltage

Channel-to-ground isolation

Continuous	250 V _{rms} , Installation Category II
Dielectric withstand.....	2,300 V _{rms} , 1 minute

Channel-to-channel isolation None

Environmental

FieldPoint modules are intended for indoor use only. For outdoor use, they must be mounted inside a sealed enclosure.

Operating temperature -40 to 70 °C

Storage temperature -55 to 85 °C

Humidity 10 to 90% RH,
noncondensing

Maximum altitude..... 2,000 m; at higher altitudes
the isolation voltage ratings
must be lowered.

Pollution Degree 2

Shock and Vibration

These specifications apply only to the cFP-AI-100.

NI recommends Compact FieldPoint if your application is subject to shock and vibration.

Operating vibration, random
(IEC 60068-2-64)..... 10–500 Hz, 5 g_{rms}

Operating vibration, sinusoidal
(IEC 60068-2-6)..... 10–500 Hz, 5 g

Operating shock
(IEC 60068-2-27)..... 50 g, 3 ms half sine,
18 shocks at 6 orientations;
30 g, 11 ms half sine,
18 shocks at 6 orientations

Safety

This product is designed to meet the requirements of the following standards of safety for electrical equipment for measurement, control, and laboratory use:

- IEC 61010-1, EN 61010-1
- UL 61010-1
- CAN/CSA-C22.2 No. 61010-1



Note For UL, hazardous locations, and other safety certifications, refer to the product label, or visit ni.com/certification, search by model number or product line, and click the appropriate link in the Certification column.

Electromagnetic Compatibility

Emissions.....	EN 55011 Class A at 10 m FCC Part 15A above 1 GHz
Immunity.....	EN 61326:1997 + A2:2001, Table 1

CE, C-Tick, and FCC Part 15 (Class A) Compliant



Note For EMC compliance, operate this device with shielded cabling.

CE Compliance

This product meets the essential requirements of applicable European Directives, as amended for CE marking, as follows:

Low-Voltage Directive (safety).....	73/23/EEC
Electromagnetic Compatibility Directive (EMC)	89/336/EEC



Note Refer to the Declaration of Conformity (DoC) for this product for any additional regulatory compliance information. To obtain the DoC for this product, visit ni.com/certification, search by model number or product line, and click the appropriate link in the Certification column.

Mechanical Dimensions

Figure 8 shows the mechanical dimensions of the FP-AI-100 installed on a terminal base. If you are using the cFP-AI-100, refer to the Compact FieldPoint controller user manual for the dimensions and cabling clearance requirements of the Compact FieldPoint system.

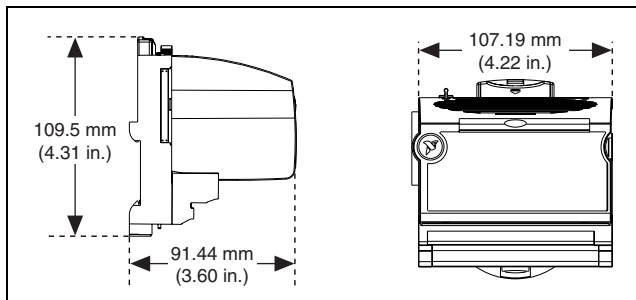

Figure 8. FP-AI-100 Mechanical Dimensions

Where to Go for Support

For more information about setting up the FieldPoint system, refer to these National Instruments documents:

- FieldPoint network module user manual
- Other FieldPoint I/O module operating instructions
- FieldPoint terminal base and connector block operating instructions

Go to ni.com/support for the most current manuals, examples, and troubleshooting information.

National Instruments corporate headquarters is located at 11500 North Mopac Expressway, Austin, Texas, 78759-3504. National Instruments also has offices located around the world to help address your support needs. For telephone support in the United States, create your service request at ni.com/support and follow the calling instructions or dial 512 795 8248. For telephone support outside the United States, contact your local branch office:

Australia 1800 300 800, Austria 43 0 662 45 79 90 0,
Belgium 32 0 2 757 00 20, Brazil 55 11 3262 3599,
Canada (Calgary) 403 274 9391, Canada (Ottawa) 613 233 5949,
Canada (Québec) 450 510 3055, Canada (Toronto) 905 785 0085,
Canada (Vancouver) 604 685 7530, China 86 21 6555 7838,
Czech Republic 420 224 235 774, Denmark 45 45 76 26 00,
Finland 385 0 9 725 725 11, France 33 0 1 48 14 24 24,
Germany 49 0 89 741 31 30, India 91 80 51190000,
Israel 972 0 3 6393737, Italy 39 02 413091,
Japan 81 3 5472 2970, Korea 82 02 3451 3400,
Malaysia 603 9131 0918, Mexico 01 800 010 0793,
Netherlands 31 0 348 433 466, New Zealand 0800 553 322,
Norway 47 0 66 90 76 60, Poland 48 22 3390150,
Portugal 351 210 311 210, Russia 7 095 783 68 51,
Singapore 65 6226 5886, Slovenia 386 3 425 4200,
South Africa 27 0 11 805 8197, Spain 34 91 640 0085,
Sweden 46 0 8 587 895 00, Switzerland 41 56 200 51 51,
Taiwan 886 2 2528 7227, Thailand 662 992 7519,
United Kingdom 44 0 1635 523545

FieldPoint™, National Instruments™, NI™, and ni.com™ are trademarks of National Instruments Corporation. Product and company names mentioned herein are trademarks or trade names of their respective companies. For patents covering National Instruments products, refer to the appropriate location: **Help»Patents** in your software, the `patents.txt` file on your CD, or ni.com/patents.

