

## COMPREHENSIVE SERVICES

We offer competitive repair and calibration services, as well as easily accessible documentation and free downloadable resources.

## SELL YOUR SURPLUS

We buy new, used, decommissioned, and surplus parts from every NI series. We work out the best solution to suit your individual needs.

 Sell For Cash    Get Credit    Receive a Trade-In Deal

## OBSOLETE NI HARDWARE IN STOCK & READY TO SHIP

We stock **New**, **New Surplus**, **Refurbished**, and **Reconditioned** NI Hardware.



*Bridging the gap between the manufacturer and your legacy test system.*

 1-800-915-6216

 [www.apexwaves.com](http://www.apexwaves.com)

 [sales@apexwaves.com](mailto:sales@apexwaves.com)

*All trademarks, brands, and brand names are the property of their respective owners.*

**Request a Quote**

 **CLICK HERE**

**FP-AI-V10**

## FP-TB-10

### Terminal Base and Dual-Channel FieldPoint Modules

These operating instructions describe the installation, features, and characteristics of the FP-TB-10 terminal base and of the various dual-channel modules that work with it. For details on configuring and accessing these modules over a network, refer to the user manual for the particular FieldPoint network module you are using with the dual-channel system.

## Features

---

The FP-TB-10 and the dual-channel FieldPoint modules have the following features:

- High granularity of system design with up to six dual-channel I/O modules per terminal base
- Any combination of I/O types in each terminal base
- Independent isolation of each dual-channel I/O module

FieldPoint dual-channel I/O modules offer maximum flexibility in configuring I/O systems. You can mount up to six dual-channel modules in any combination on the FP-TB-10 terminal base. You can mix dual-channel modules with standard eight- and 16-channel modules in a single FieldPoint bank. Therefore, you can configure your FieldPoint system to match your specific I/O needs, minimizing the size and cost of your distributed I/O system. In addition, the dual-channel modules provide a flexible solution for applications requiring channel-to-channel isolation.

---

FieldPoint™, National Instruments™, NI™, and ni.com™ are trademarks of National Instruments Corporation. Product and company names mentioned herein are trademarks or trade names of their respective companies. For patents covering National Instruments products, refer to the appropriate location: **Help»Patents** in your software, the `patents.txt` file on your CD, or `ni.com/patents`.

# Mounting the Terminal Base on a DIN Rail



**Note** Before you connect a terminal base to a network module, the network module *must* be powered off.

1. With a flathead screwdriver, open the rail clip to the unlocked position as shown in the following figure.

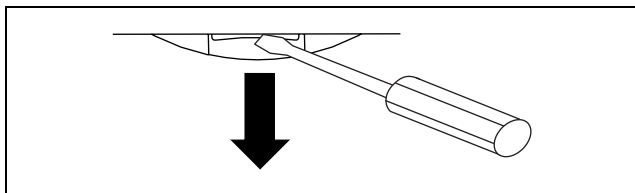

**Figure 1.** Opening the Rail Clip on the Terminal Base

2. Hook the lip on the rear of the terminal base onto the top of a 35 mm DIN rail and rotate the terminal base down onto the DIN rail as shown in the following figure.

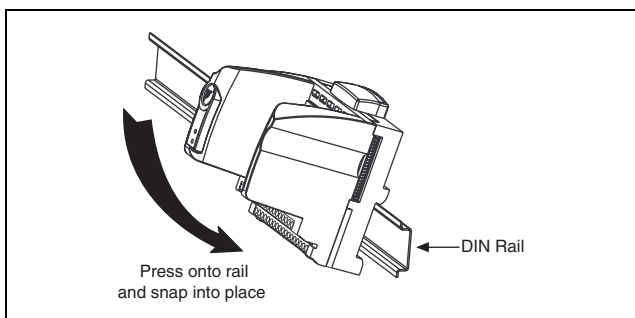

**Figure 2.** Mounting the Terminal Base on a DIN Rail

3. Slide the terminal base along the DIN rail until its local bus connector mates with the connector of the terminal base or network module adjacent to it.
4. Lock the terminal base to the DIN rail by pushing in the rail clip.
5. Continue adding as many terminal bases as you need to the DIN rail, up to nine terminal bases per network module. Be sure to mate the local bus connectors.

- Place the protective cover over the local bus connector of the last terminal base in the stack. The following figure shows an installed terminal base.

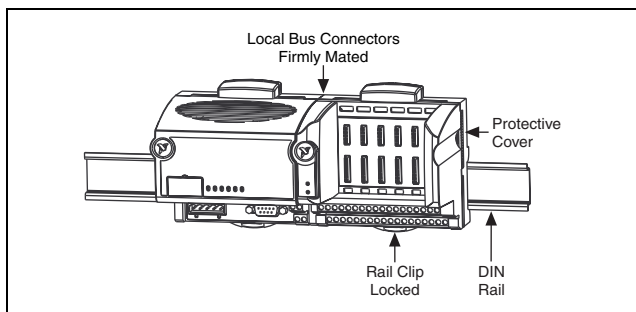

**Figure 3.** Terminal Base Installed on a DIN Rail

## Mounting the Terminal Base on a Panel

- With a flathead screwdriver, open the rail clip to the unlocked position.
- Snap the panel-mount accessory onto the bottom of the terminal base as shown in the following figure.

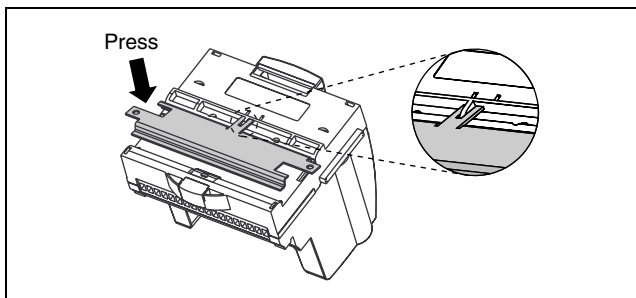

**Figure 4.** Snapping the Panel-Mount Accessory onto the Terminal Base

- Lock the rail clip.
- Mount the FP-TB-10 and panel-mount accessory onto the desired surface. You can drill pilot holes using the directions in the panel-mount adapter installation guide.

Install the network module first, using two bolts or screws, then install the FP-TB-10 using the right bolt tab. If you use a FieldPoint bus extender cable, the first FP-TB-10 on the new row should use both panel-mount bolt tabs.

## Installing Dual-Channel I/O Modules

You can install up to six dual-channel modules on each FP-TB-10 terminal base. You can use any combination of modules in any order on the terminal base.

To install a dual-channel module on an FP-TB-10, snap the module onto the terminal base while squeezing the legs of the module inward. Install the modules with the colored label oriented toward the top. Make sure that both legs of the module snap securely into place.

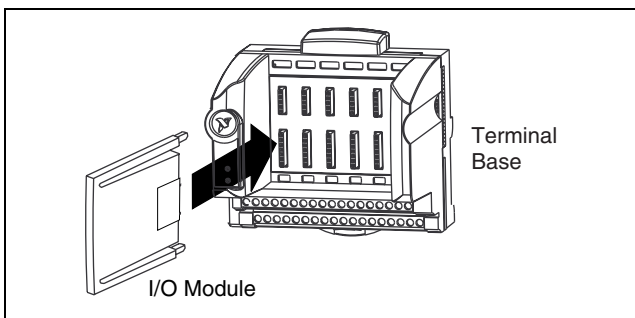

**Figure 5.** Installing a Dual-Channel Module in the Terminal Base

To remove a dual-channel module, squeeze the legs of the module together to unlock, then pull from the terminal base.

## Hot Plug-and-Play Live Insertion and Swapping of Modules

You can install modules while the network module is powered and in operation. Replacing any dual-channel module with another dual-channel module of the same type will not interrupt the FieldPoint system's operation, but while a module is missing, it will be reported as having a bad status. The new dual-channel module will be automatically configured with the same settings as the previous module, and if it is an output module, the output value will be automatically updated. However, if you replace a module

with a module of a different type, the FP-TB-10 will reset itself and all six of its modules and will request new initial configuration settings from the network module.

## Field Wiring

The FP-TB-10 has four screw-terminal connections for each of the six dual-channel modules. These four connections are labeled *1a* and *1b* for channel 1, and *2a* and *2b* for channel 2. The signal connections for each of the different I/O modules are listed in these instructions and are also printed on the sides of each of the I/O modules. In addition to these terminals are six pairs of terminals labeled *V* and *C*. These *V* and *C* terminals are not directly connected to the dual-channel modules, but all of the *V* terminals are connected together and all of the *C* terminals are connected together. You can use these terminals to connect external power supplies to the dual-channel modules or to send power to field devices, but you do not need to connect anything to the *V* and *C* terminals in order to use the dual-channel modules.

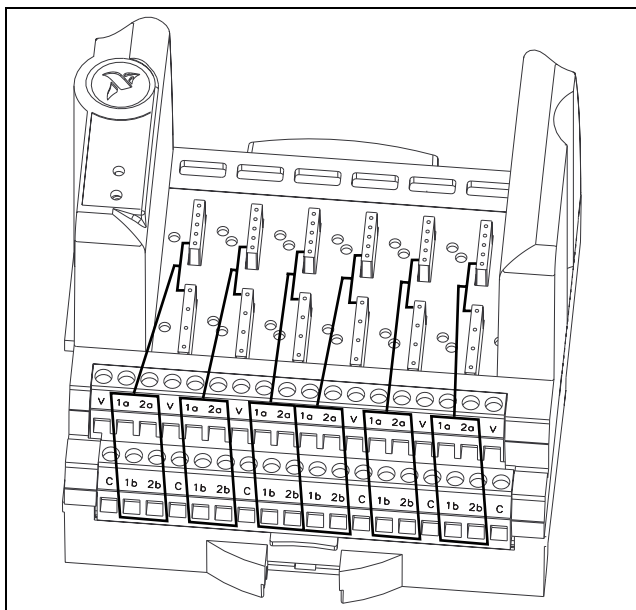

**Figure 6.** Module Slots and the Screw Terminals Associated with Them

Some dual-channel modules, such as the thermocouple and four-wire RTD modules, provide other means of making field-wiring connections.

## Update Rates

---

The FP-TB-10 continuously scans through its six dual-channel modules, updating outputs and reading inputs. The scan rate varies depending on the modules in the FP-TB-10. Empty slots and digital modules add 0.2 ms each to the scan time, and analog modules add 1.5 ms each. The sum of these six times is the total scan time. For example, an FP-TB-10 with two FP-AI-C020 modules, one FP-DI-DC, and three empty slots has a total scan time of 3.8 ms ( $4 \times 0.2 \text{ ms} + 2 \times 1.5 \text{ ms}$ ).

Each I/O module makes data available to or reads data from the network module once per scan time. However, the network module makes data available to and receives data from the network at rates that are independent of the operation of the FP-TB-10 and the dual-channel modules. Refer to the network module user manual for more details on the operation and throughput of your particular network.

## Power Requirement (P+)

---

The FP-TB-10 and the dual-channel modules are powered through the local backplane bus from the FieldPoint network module. An FP-TB-10 with I/O modules may require more than the nominal power allocated to an I/O module from the network module. In some applications, this power requirement could limit the number of I/O modules that you can connect to a single network module. When defining a FieldPoint system that uses an FP-TB-10, calculate the total power consumption of the FP-TB-10 with its dual-channel modules, as well as the power consumption of the other I/O modules in the system. The total power consumption of all these modules must be less than 9 W. The FP-TB-10 alone requires 0.20 W of power; add to this the individual power requirements of the dual-channel modules given in the *Specifications* section.

For example, an FP-TB-10 with three FP-AO-C020 dual-channel modules and two FP-AI-C020 dual-channel modules requires 4.25 W of power ( $0.20 \text{ W} + 3 \times 1.1 \text{ W} + 2 \times 0.375 \text{ W}$ ). A bank of FieldPoint modules including two such FP-TB-10 bases uses 8.5 W of power—nearly the entire 9 W limit.

# Dual-Channel I/O Modules

Dual-channel I/O modules are available for current and voltage input and output, thermocouple and RTD input, and discrete input and output. This section describes the different modules and shows how to connect external circuits to them.

## Analog Current Input Modules (FP-AI-C020 and FP-AI-C420)

The FP-AI-C020 and the FP-AI-C420 are dual-channel current input modules that provide 12-bit-resolution measurements. Each channel has a programmable filter with two settings, 20 Hz bandwidth and 100 Hz bandwidth. Each channel has  $133\ \Omega$  input impedance. On the FP-AI-C020, the two channels share a common reference point (the “b” terminals). On the FP-AI-C420, there is  $400\ \text{k}\Omega$  of resistance between 1b and 2b. Wire field devices so that current flows into the “a” terminals and out of the “b” terminals. You can use the V and C terminals to connect loop power supplies and current transmitters.



**Note** If your application requires channel-to-channel isolation, use only one channel of each module.

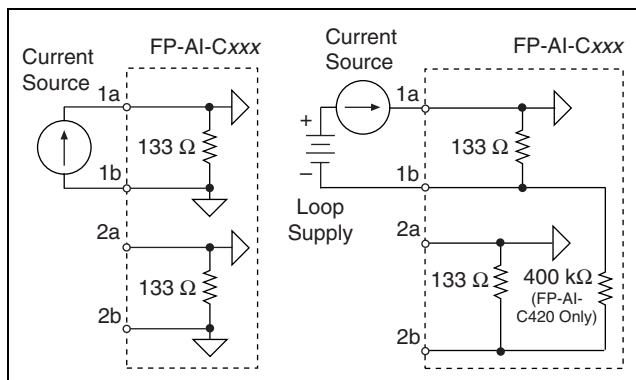

**Figure 7.** Analog Current Input Module Signal Connections



## Analog Voltage Input Modules (FP-AI-V50m, FP-AI-V100m, FP-AI-V1, FP-AI-V5, FP-AI-V5B, FP-AI-V10, and FP-AI-V10B)

The FP-AI-V50m, FP-AI-V100m, FP-AI-V1, FP-AI-V5, FP-AI-V5B, FP-AI-V10, and FP-AI-V10B are dual-channel analog voltage input modules that provide 12-bit-resolution measurements. Each channel has a programmable filter with two settings, 20 Hz bandwidth and 2 kHz bandwidth. The two channels share a common reference point, the “b” terminals. The “a” terminal for each channel is the positive input.



**Note** If your application requires channel-to-channel isolation, use only one channel of each module.

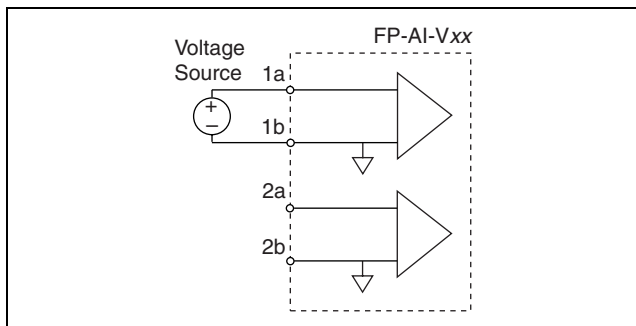

**Figure 8.** Analog Voltage Input Module Signal Connections

## Analog Thermocouple Input Modules (FP-TC-J, FP-TC-K, and FP-TC-T)

The FP-TC-J, FP-TC-K, and FP-TC-T are dual-channel input modules for J-, K-, and T-type thermocouples, respectively. These modules provide 12-bit-resolution measurements, and each channel can be programmed for either the °C or the °F scale. These modules do not use the screw terminals of the FP-TB-10. Wire your thermocouple signals to the thermocouple connectors on the top of the module.



**Note** If your application requires channel-to-channel isolation, use only one channel of each module.

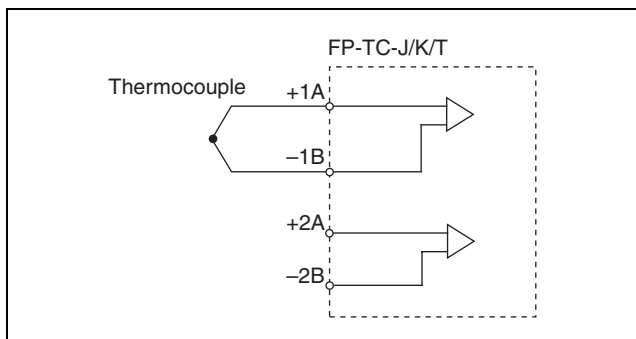

**Figure 9.** Thermocouple Input Module Signal Connections

## RTD Input Modules (FP-RTD-PT100, FP-RTD-PT100-3, and FP-RTD-PT100-4)

The FP-RTD-PT100, FP-RTD-PT100-3, and FP-RTD-PT100-4 are dual-channel input modules for two-, three-, and four-wire 100  $\Omega$  platinum RTDs respectively. They provide 12-bit-resolution measurements. Each module is designed with the linearization curves of a DIN 43760 standard RTD ( $\alpha = 0.00385$ ). Each channel can be programmed for either the °C or the °F scale.



**Note** If your application requires channel-to-channel isolation, use only one channel of each module.

The FP-RTD-PT100 connects to two FP-TB-10 screw terminals per channel. The “b” terminal is common for both channels. The FP-RTD-PT100-3 has two sets of screw terminals on top and does

not connect to the screw terminals on the FP-TB-10. A legend on the side of the module shows the names of the terminals. The following diagram shows which screw terminals to use for each module.

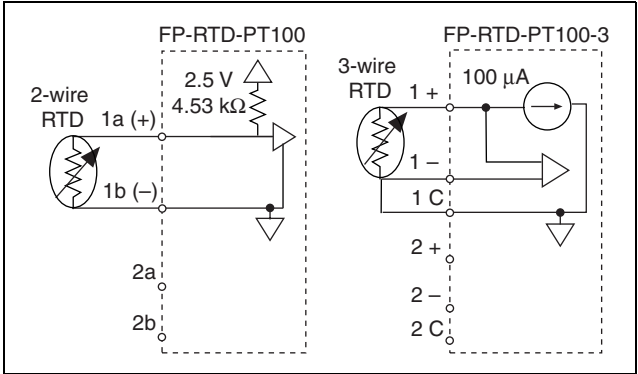

**Figure 10.** Two- and Three-Wire RTD Input Module Signal Connections

The FP-RTD-PT100-4 also has top-mounted screw-terminal connectors. The wiring examples in the following figure use both channels on each module. The bottom example is of a three-wire RTD circuit.

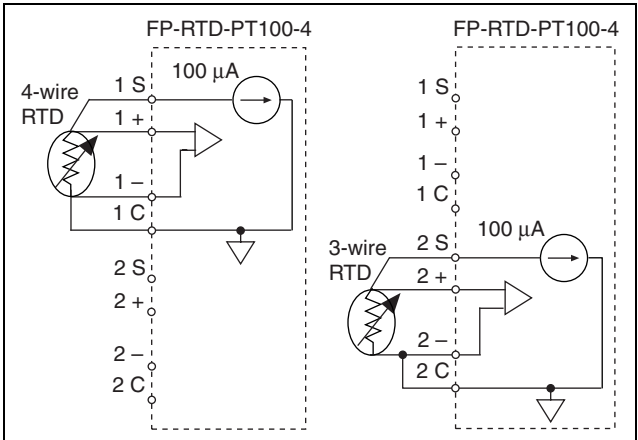

**Figure 11.** Connecting Four-Wire and Three-Wire RTDs to the FP-RTD-PT100-4

## Analog Current Output Modules (FP-AO-C020, FP-AO-C420, and FP-AO-C024)

The FP-AO-C020, FP-AO-C420, and FP-AO-C024 are dual-channel current output modules that provide 12-bit-resolution outputs. All three modules have internal loop power supplies that can drive loads of up to 500  $\Omega$ . Wire your field devices so that current flows out of the “a” terminals and returns through the “b” terminals.



**Note** The “a” terminals serve as a common reference point for the two channels, so if your application requires channel-to-channel isolation, use only one channel of each module.

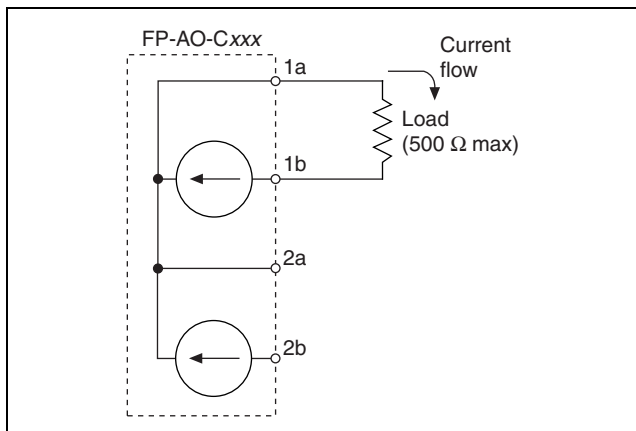

**Figure 12.** Connecting an Analog Current Output Module to a Load

## Analog Voltage Output Modules (FP-AO-V5, FP-AO-V5B, FP-AO-V10, and FP-AO-V10B)

The FP-AO-V5, FP-AO-V5B, FP-AO-V10, and FP-AO-V10B are dual-channel analog voltage output modules that provide 12-bit-resolution measurements. The power supplies in these modules can drive loads with up to 20 mA of current; however, each channel has 10  $\Omega$  output impedance, which adds 10 mV of error for each milliampere that the channel is required to supply.



**Note** The “b” terminals serve as a common reference point for the two channels, so if your application requires channel-to-channel isolation, use only one channel of each module.

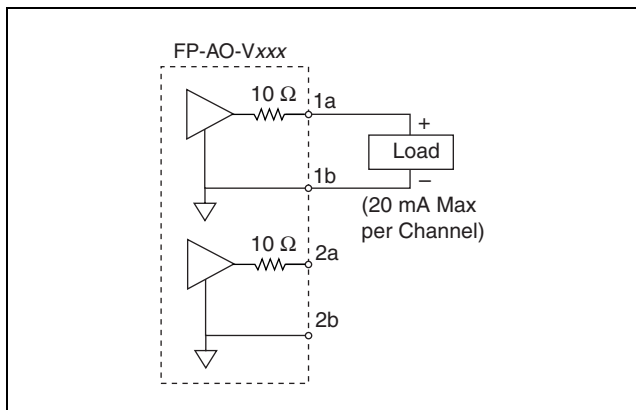
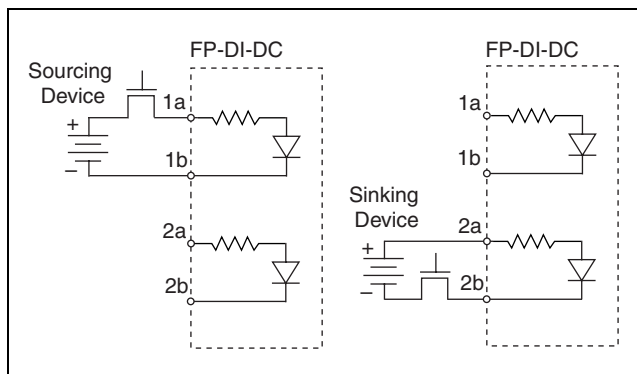

**Figure 13.** Connecting an Analog Voltage Output Module to a Load

## Discrete Input Modules (FP-DI-DC, FP-DI-AC120, and FP-DI-AC240)

The FP-DI-DC, FP-DI-AC120, and FP-DI-AC240 are discrete input modules. Each module has two isolated channels, so applications requiring channel-to-channel isolation can use both channels on each module. Each module has two green indicator LEDs, one for each channel, to indicate whether the channel is in the ON or the OFF state. A channel is in the ON state when a voltage above the threshold is present between the “a” and “b” terminals. Because each channel of the DC input modules is

isolated, each can be used with either sinking or sourcing devices. If you do not need channel-to-channel isolation, you can use the V and C terminals to bus-connect power supplies for discrete-output field devices.



**Figure 14.** Connecting Sourcing and Sinking Devices to the FP-DI-DC

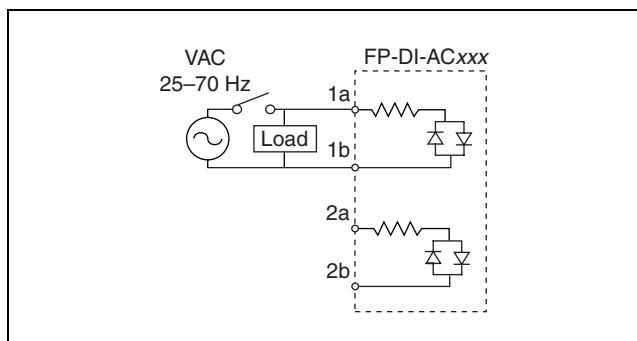

**Figure 15.** Wiring Diagram for Discrete AC Input Modules

## Discrete Output Modules (FP-DO-DC60, FP-DO-DC200, FP-DO-AC120, and FP-DO-AC240)

The FP-DO-DC60, FP-DO-DC200, FP-DO-AC120, and FP-DO-AC240 are discrete output modules. Each module has two isolated channels, so applications requiring channel-to-channel isolation can use both channels on each module. Each module has two green indicator LEDs, one for each channel, to indicate whether the channel is in the ON or the OFF state. Each module also has two replaceable fuses—one for each channel. The amount of current that each channel can drive without exceeding temperature specifications depends on the ambient temperature and the module type—see the [Specifications](#) section for more details. Because each channel of the DC output modules is isolated, each can be used with either sinking or sourcing devices. These modules sink current into the “a” terminals and source current out of the “b” terminals. The following figures show examples of this wiring. The AC output modules have zero-crossing triac-style outputs that turn on as the voltage crosses zero and turn off as the current crosses zero. If your application does not require channel-to-channel isolation, you can use the V and C terminals on the FP-TB-10 to bus-connect power supplies for your loads.

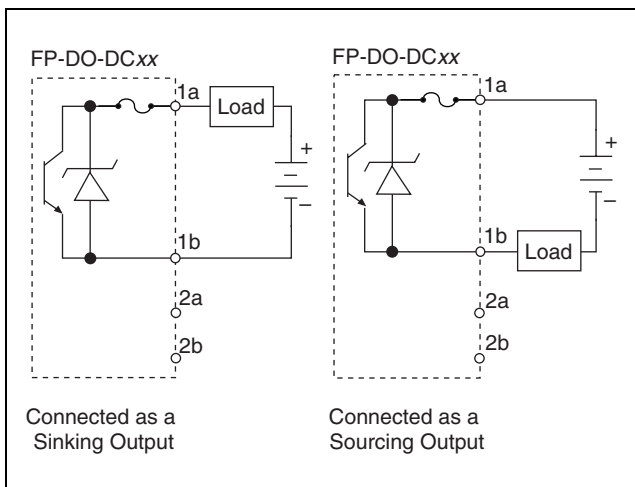

**Figure 16.** Signal Connections for Discrete DC Output Modules

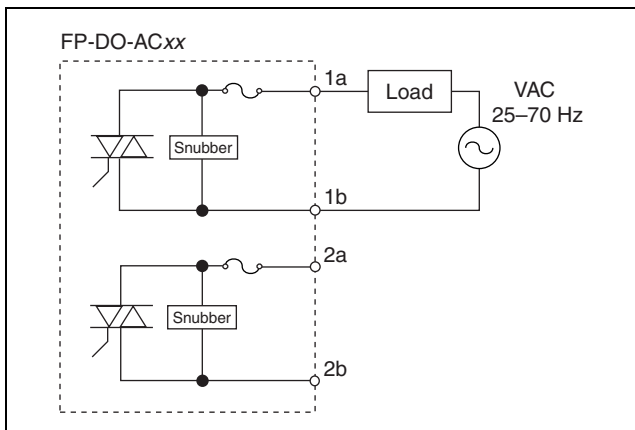

Figure 17. Signal Connections for Discrete AC Output Modules

## Updating Your Firmware and Software for Use with the FP-TB-10

You may need to upgrade your FieldPoint firmware when you add the FP-TB-10 to your FieldPoint system. To determine which firmware you need and how to upgrade to it, use your Web browser to go to [ni.com/info](http://ni.com/info) and enter `fpmatrix`.

## Isolation and Safety Guidelines



**Caution** Read the following information before attempting to connect the FP-TB-10 to any circuits that may contain hazardous voltages.

This section describes the isolation of the FP-TB-10 and its compliance with international safety standards. The field wiring connections are isolated from the backplane and the inter-module communication bus. The isolation is provided by the module, which has optical and galvanic isolation barriers designed and tested to protect against transient fault voltages of up to  $2,500 V_{\text{rms}}$ . The FP-TB-10 provides *double insulation* (compliant with IEC 61010-1) for working common-mode voltages of  $250 V_{\text{rms}}$ . Safety standards (such as those published by UL and IEC) require the use of double insulation between hazardous voltages and any human-accessible parts or circuits.



*Never* try to use any isolation product between human-accessible parts (such as DIN rails or monitoring stations) and circuits that can be at hazardous potentials under normal conditions, unless the product is specifically designed for such an application, as is the FP-TB-10.

Even though the FP-TB-10 is designed to handle applications with hazardous potentials, follow these guidelines to ensure a safe total system:

- The FP-TB-10 has a safety isolation barrier between the I/O channels and the inter-module communication bus. There is no isolation between channels unless otherwise noted. If any of the channels on a module are wired at a hazardous potential, make sure that all other devices or circuits connected to that module are properly insulated from human contact.
- Do *not* share the external supply voltages (V and C on the terminal base) with other devices (including other FieldPoint devices), unless those devices are isolated from human contact.
- As with any hazardous voltage wiring, make sure that all wiring and connections meet applicable electrical codes and commonsense practices. Mount terminal bases in an area, position, or cabinet that prevents accidental or unauthorized access to wiring that carries hazardous voltages.
- The isolation of the FP-TB-10 is certified as double-insulated for normal operating voltages of  $250 V_{\text{rms}}$ . Do *not* use the FP-TB-10 as the only isolating barrier between human contact and working voltages of more than  $250 V_{\text{rms}}$ .
- Operate the FP-TB-10 only at or below pollution degree 2. Pollution degree 2 means that only nonconductive pollution occurs in most cases. Occasionally, however, a temporary conductivity caused by condensation must be expected.
- Do *not* operate FieldPoint products in an explosive atmosphere or where there may be flammable gases or fumes. If you need to operate FieldPoint products in such an environment, the FieldPoint products *must* be in a suitably rated enclosure.
- Operate the FP-TB-10 at or below Installation Category II. Installation Category II is for measurements performed on circuits directly connected to the low-voltage installation. This category refers to local-level distribution, such as that provided by a standard wall outlet.

# Specifications

---

## Analog Input Modules

### Number of inputs

Thermocouple modules .....	2 differential
Other types .....	2 single-ended

Measurement resolution..... 12 bits (1 part in 4,096)

### Input impedance

Voltage inputs .....	2.2 M $\Omega$
Current inputs .....	133 $\Omega$

### Excitation current (RTDs)

Four-wire .....	100 $\mu$ A
Three-wire .....	100 $\mu$ A
Two-wire .....	550 $\mu$ A

### Measurement bandwidth

Voltage inputs .....	20 Hz or 2 kHz, programmable
Current inputs .....	20 Hz or 100 Hz
Thermocouple inputs.....	20 Hz
RTD inputs .....	15 Hz

### Step response time

Voltage and current inputs.....	1.5 ms
RTD inputs .....	42 ms
Thermocouple inputs.....	100 ms

### Input protection

Current inputs .....	38 mA
Voltage inputs .....	$\pm$ 30 V
Thermocouple, RTD.....	$\pm$ 6 V

**Table 1. Analog Input Module Accuracy**

Module	Input Range	Resolution	Accuracy (at 25 °C)	Temperature Drift*
FP-AI-V50m	0 to 50 mV	12.2 $\mu$ V	$\pm 0.07\%$	1.8 $\mu$ V + 75 ppm
FP-AI-V100m	0 to 100 mV	24.4 $\mu$ V	$\pm 0.07\%$	3.5 $\mu$ V + 75 ppm
FP-AI-V1	0 to 1 V	244 $\mu$ V	$\pm 0.075\%$	35 $\mu$ V + 75 ppm
FP-AI-V5	0 to 5 V	1.22 mV	$\pm 0.075\%$	125 $\mu$ V + 75 ppm
FP-AI-V5B	$\pm 5$ V	2.44 mV	$\pm 0.075\%$	250 $\mu$ V + 75 ppm
FP-AI-V10	0 to 10 V	2.44 mV	$\pm 0.075\%$	250 $\mu$ V + 75 ppm
FP-AI-V10B	$\pm 10$ V	4.88 mV	$\pm 0.075\%$	500 $\mu$ V + 75 ppm
FP-AI-C020	0 to 20 mA	4.9 $\mu$ A	$\pm 0.075\%$	0.5 $\mu$ A + 75 ppm
FP-AI-C420	4 to 20 mA	3.9 $\mu$ A	$\pm 0.075\%$	0.5 $\mu$ A + 75 ppm
FP-TC-J	-210 to 1200 °C -346 to 2192 °F	0.34 °C 0.62 °F	$\pm 1$ °C $\pm 1.8$ °F**	0.07 °C + 100 ppm 0.13 °F + 100 ppm
FP-TC-K	-100 to 1372 °C -148 to 2501 °F	0.36 °C 0.65 °F	$\pm 1$ °C $\pm 1.8$ °F**	0.07 °C + 100 ppm 0.13 °F + 100 ppm
FP-TC-T	-240 to 400 °C -400 to 752 °F	0.16 °C 0.28 °F	$\pm 0.4$ °C $\pm 0.7$ °F***	0.03 °C + 100 ppm 0.06 °F + 100 ppm
FP-RTD-PT100	-50 to 350 °C -58 to 662 °F	0.1 °C 0.18 °F	$\pm 0.3$ °C $\pm 0.54$ °F	0.03 °C + 100 ppm 0.06 °F + 100 ppm
FP-RTD-PT100-3	-50 to 350 °C -58 to 662 °F	0.1 °C 0.18 °F	$\pm 0.3$ °C $\pm 0.54$ °F	0.03 °C + 100 ppm 0.06 °F + 100 ppm
FP-RTD-PT100-4	-50 to 350 °C -58 to 662 °F	0.1 °C 0.18 °F	$\pm 0.3$ °C $\pm 0.54$ °F	0.03 °C + 100 ppm 0.06 °F + 100 ppm

\* Temperature drift equals (offset + gain) / °C.  
\*\*  $\pm 2$  °C ( $\pm 3.6$  °F) over full input range  
\*\*\*  $\pm 0.8$  °C ( $\pm 1.4$  °F) over full input range

## Analog Output Modules

Number of outputs ..... 2 single-ended

Output resolution ..... 12 bits (1 part in 4,096)

Output impedance

(voltage outputs) ..... 10  $\Omega$

Current drive (voltage outputs) ..... 20 mA

Maximum load (current outputs) ..... 500  $\Omega$

Step response time

Current outputs ..... 500  $\mu$ s

Voltage outputs ..... 800  $\mu$ s

**Table 2.** Analog Output Module Accuracy

Module	Output Range	Resolution	Accuracy (at 25 °C)	Temperature Drift*
FP-AO-C020	0 to 20 mA	4.9 $\mu$ A	$\pm 0.1\%$	1 $\mu$ A + 75 ppm
FP-AO-C420	4 to 20 mA	3.9 $\mu$ A	$\pm 0.1\%$	1 $\mu$ A + 100 ppm
FP-AO-C024	0 to 24 mA	5.9 mA	$\pm 0.1\%$	1.2 $\mu$ A + 100 ppm
FP-AO-V5	0 to 5 V	1.2 mV	$\pm 0.08\%$	125 $\mu$ V + 100 ppm
FP-AO-V5B	$\pm 5$ V	2.4 mV	$\pm 0.08\%$	250 $\mu$ V + 100 ppm
FP-AO-V10	0 to 10 V	2.4 mV	$\pm 0.06\%$	250 $\mu$ V + 100 ppm
FP-AO-V10B	$\pm 10$ V	4.9 mV	$\pm 0.06\%$	500 $\mu$ V + 100 ppm

\* Temperature drift equals (offset + gain) / °C.

## Discrete Input Modules

Number of channels..... Two isolated inputs

**Table 3.** Discrete Input Characteristics

	FP-DI-DC	FP-DI-AC120	FP-DI-AC240
Nominal input	5 to 24 VDC	120 VAC	240 VAC
Voltage range	0 to 32 VDC	0 to 140 VAC/VDC	0 to 280 VAC/VDC
Voltage level ON state, min OFF state, max	3.0 VDC 0.9 VDC	90 VAC 25 VAC	180 VAC 50 VAC
Current level ON state, min OFF state, max	1.7 mA 0.5 mA	4.1 mA 1.1 mA	2.8 mA 0.8 mA
Input impedance	1.8 k $\Omega$	22 k $\Omega$	64 k $\Omega$
Delay time (max)	0.4 ms	20 ms	20 ms

## Discrete Output Modules

Number of channels..... Two isolated outputs

Replaceable fuses (5  $\times$  20 mm, 3.15 A, 250 V, fast-acting)

FP-DO-DC, FP-DO-AC ..... Littelfuse 217315

**Table 4.** Discrete Output Characteristics

	<b>FP-DO-DC60</b>	<b>FP-DO-DC200</b>	<b>FP-DO-AC120</b>	<b>FP-DO-AC240</b>
Voltage range	3 to 60 VDC	4 to 200 VDC	24 to 140 VAC 25 to 70 Hz	24 to 280 VAC 25 to 70 Hz
Voltage drop	1.3 V at 0.75 A	1.75 V at 1.0 A	1.0 V at 0.5 A	1.0 V at 0.5 A
Current rating (per channel)	0.75 A at 25 °C 0.50 A at 40 °C 0.30 A at 60 °C	0.40 A at 25 °C 0.20 A at 40 °C 0.10 A at 60 °C	0.75 A at 25 °C 0.50 A at 40 °C 0.30 A at 60 °C	0.75 A at 25 °C 0.50 A at 40 °C 0.30 A at 60 °C
Max leakage	1.5 mA	0.01 mA	2 mA rms	4 mA rms
Max output delay	0.06 ms	0.75 ms	1/2 cycle	1/2 cycle

## Power Requirements

FP-TB-10 ..... 200 mW

### Analog input modules

FP-AI-V50m, FP-AI-100m ..... 300 mW

FP-AI-C020, FP-AI-C420,

FP-AI-V1, FP-AI-V5,

FP-AI-V10, FP-AI-V5B,

FP-AI-V10B, FP-RTD-PT100,

FP-RTD-PT100-3,

FP-RTD-PT100-4,

FP-TC-J, FP-TC-K, FP-TC-T .... 375 mW max

### Analog output modules

FP-AO-C020, FP-AO-C420,

FP-AO-C024..... 1100 mW at max output

FP-AO-V5, FP-AO-V10,

FP-AO-V5B, FP-AO-V10B ..... 1100 mW at max output

### Discrete input modules

FP-DI-DC, FP-DI-AC120,

FP-DI-AC240 ..... 60 mW

### Discrete output modules

FP-DO-DC60, FP-DO-DC200,

FP-DO-AC120,

FP-DO-AC240..... 70 mW

## Scan Times

Analog input/output modules ..... 1.5 ms

Discrete input/output modules  
and empty slots ..... 0.2 ms

## Physical Characteristics

Field-wiring diameter ..... 24 to 12 AWG

### Weight

FP-TB-10 ..... 290 g (10.2 oz)

I/O module ..... 60 g (2.1 oz)

### Operating temperature

FP-TB-10 ..... -40 to 70 °C

Discrete modules ..... -40 to 70 °C

Analog modules ..... -40 to 70 °C

Storage temperature ..... -40 to 85 °C

## Mechanical Dimensions

The following figure shows the mechanical dimensions of the FP-TB-10. Dimensions are given in inches [millimeters].

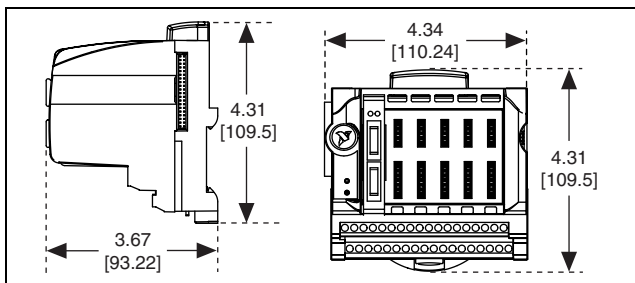

**Figure 18.** Mechanical Dimensions of the FP-TB-10

## Where to Go for Support

For more information about setting up your FieldPoint system, refer to these National Instruments documents:

- Your FieldPoint network module user manual
- Your other FieldPoint I/O module operating instructions
- Your FieldPoint terminal base operating instructions

Go to [ni.com/support](http://ni.com/support) for the most current manuals, examples, and troubleshooting information.

For telephone support in the United States, create your service request at [ni.com/ask](http://ni.com/ask) and follow the calling instructions or dial 512 795 8248. For telephone support outside the United States, contact your local branch office:

Australia 03 9879 5166, Austria 0662 45 79 90 0,  
Belgium 02 757 00 20, Brazil 011 284 5011,  
Canada (Calgary) 403 274 9391, Canada (Montreal) 514 288 5722,  
Canada (Ottawa) 613 233 5949, Canada (Québec) 514 694 8521,  
Canada (Toronto) 905 785 0085, China (Shanghai) 021 6555 7838,  
China (ShenZhen) 0755 3904939, Denmark 45 76 26 00,  
Finland 09 725 725 11, France 01 48 14 24 24,  
Germany 089 741 31 30, Greece 30 1 42 96 427,  
Hong Kong 2645 3186, India 91 80 4190000,  
Israel 03 6120092, Italy 02 413091, Japan 03 5472 2970,  
Korea 02 596 7456, Malaysia 603 9596711, Mexico 5 280 7625,  
Netherlands 0348 433466, New Zealand 09 914 0488,  
Norway 32 27 73 00, Poland 0 22 528 94 06,  
Portugal 351 1 726 9011, Singapore 6 2265886, Spain 91 640 0085,  
Sweden 08 587 895 00, Switzerland 056 200 51 51,  
Taiwan 02 2528 7227, United Kingdom 01635 523545