

COMPREHENSIVE SERVICES

We offer competitive repair and calibration services, as well as easily accessible documentation and free downloadable resources.

SELL YOUR SURPLUS

We buy new, used, decommissioned, and surplus parts from every NI series. We work out the best solution to suit your individual needs.

 Sell For Cash  Get Credit  Receive a Trade-In Deal

OBSOLETE NI HARDWARE IN STOCK & READY TO SHIP

We stock **New**, **New Surplus**, **Refurbished**, and **Reconditioned** NI Hardware.



Bridging the gap between the manufacturer and your legacy test system.

 1-800-915-6216

 www.apexwaves.com

 sales@apexwaves.com

All trademarks, brands, and brand names are the property of their respective owners.

Request a Quote

 **CLICK HERE**

FP-AIO-600

FieldPoint™ Operating Instructions

FP-AIO-600 and cFP-AIO-600

Four-Channel Analog Input, Four-Channel Analog Output, 12-Bit Module

These operating instructions describe how to install and use the National Instruments FP-AIO-600 and cFP-AIO-600 (referred to inclusively as the [c]FP-AIO-600). For information about configuring and accessing the [c]FP-AIO-600 over a network, refer to the user manual for the FieldPoint network module you are using.

Features

The [c]FP-AIO-600 is a FieldPoint analog input and output module with the following features:

- Four analog voltage or current input channels with 11 input ranges up to ± 36 V or ± 24 mA with overranging
- Four analog current output channels with 0–20 or 4–20 mA ranges without overranging
- 1.7 kHz hardware update rate
- 12-bit resolution
- –40 to 70 °C operation
- Onboard diagnostics including open current loop indicators
- Current inputs protected up to ± 100 mA or ± 10 V
- 250 V_{rms} CAT II continuous channel-to-ground isolation, verified by 2,300 V_{rms}, 5 s dielectric withstand test
- Hot swappable

Installing the FP-AIO-600

The FP-AIO-600 mounts on a FieldPoint terminal base (FP-TB-*x*), which provides operating power to the module. Installing the FP-AIO-600 onto a powered terminal base does not disrupt the operation of the bank.

To install the FP-AIO-600, refer to Figure 1 and complete the following steps:

1. Slide the terminal base key to position X.
2. Align the FP-AIO-600 alignment slots with the guide rails on the terminal base.
3. Press firmly to seat the FP-AIO-600 on the terminal base. When the module is firmly seated, the terminal base latch locks it into place.

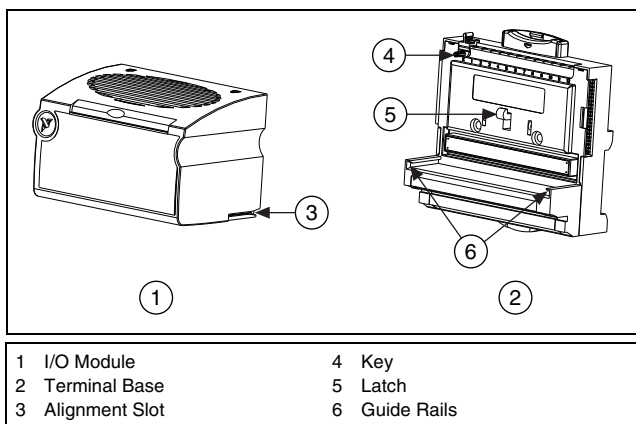

Figure 1. Installing the FP-AIO-600

Installing the cFP-AIO-600

The cFP-AIO-600 mounts on a Compact FieldPoint backplane (cFP-BP-*x*), which provides operating power to the module. Installing the cFP-AIO-600 onto a powered backplane does not disrupt the operation of the bank.

To install the cFP-AIO-600, refer to Figure 2 and complete the following steps:

1. Align the captive screws on the cFP-AIO-600 with the holes on the backplane. The alignment keys on the cFP-AIO-600 prevent backward insertion.
2. Press firmly to seat the cFP-AIO-600 on the backplane.
3. Using a number 2 Phillips screwdriver with a shank of at least 64 mm (2.5 in.) length, tighten the captive screws to $1.1 \text{ N} \cdot \text{m}$ (10 lb · in.) of torque. The nylon coating on the screws prevents them from loosening.

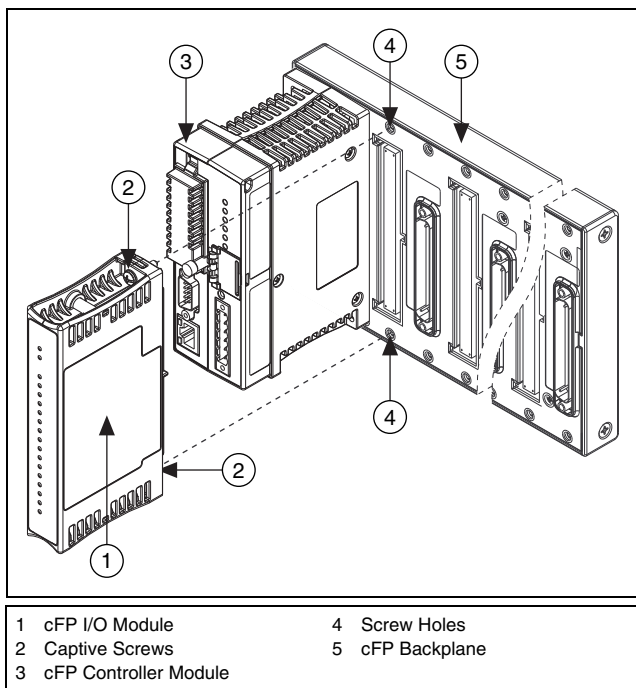

Figure 2. Installing the cFP-AIO-600

Wiring the [c]FP-AIO-600

The FP-TB- x terminal base has connections for each FP-AIO-600 input and output channel, and for an external power supply to power the current output channels and field devices. The cFP-CB- x connector block provides the same connections for the cFP-AIO-600. Each input channel has one input terminal for voltage, V_{IN} , and one input terminal for current, I_{IN} . Only one of these input terminals should be connected on each channel. Each output channel has one output terminal for current, I_{OUT} . All four input channels and all four output channels are referenced to the COM terminals. The V and V_{SUP} terminals are all internally connected, as are the C and COM terminals.

Use a 10–30 VDC external power supply that provides at least 125 mA for the output channels. The power supply must provide more current if you use it to power transducers or field devices. Connect the external power supply to multiple V and V_{SUP} terminals and to multiple C and COM terminals as needed to ensure that the maximum current through any terminal is 2 A or less.

Install a 125 mA minimum, 2 A maximum, fast-acting fuse at each connected V and V_{SUP} terminal. Select a fuse value suitable for the device connected to each channel to protect the module and connected devices. Install a 63 mA, fast-acting fuse at each connected I_{IN} terminal. The detailed wiring diagrams in this document show fuses where appropriate.

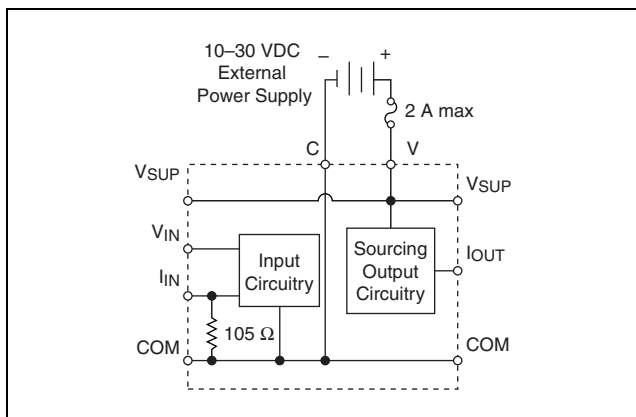

Figure 3. Basic Field Connection



Caution Do *not* connect both current and voltage inputs to the same channel.

Table 1 lists the terminal assignments for the signals of each input channel.

Table 1. Input Terminal Assignments

Channel	Inputs			
	V_{IN}	I_{IN}^1	V_{SUP}^2	COM
In 0	1	2	17	18
In 1	3	4	19	20
In 2	5	6	21	22
In 3	7	8	23	24

¹ Install a 63 mA fast-acting fuse on each I_{IN} terminal.
² Install a 2 A maximum fast-acting fuse on each V_{SUP} terminal.

Table 2 lists the terminal assignments for the signals of each output channel.

Table 2. Output Terminal Assignments

Channel	Outputs		
	I_{OUT}	V_{SUP}^1	COM
Out 0	9	25	10, 26
Out 1	11	27	12, 28
Out 2	13	29	14, 30
Out 3	15	31	16, 32

¹ Install a 2 A maximum fast-acting fuse on each V_{SUP} terminal.



Caution Cascading power between two modules defeats isolation between those modules.

Connecting Signals to the [c]FP-AIO-600

The [c]FP-AIO-600 has four single-ended input channels. All four input channels share a common ground reference that is isolated from other modules in the FieldPoint system.



Note The input and output channels of the [c]FP-AIO-600 are *not* electrically isolated from each other.

Figure 4 shows the input circuitry on a single input channel.

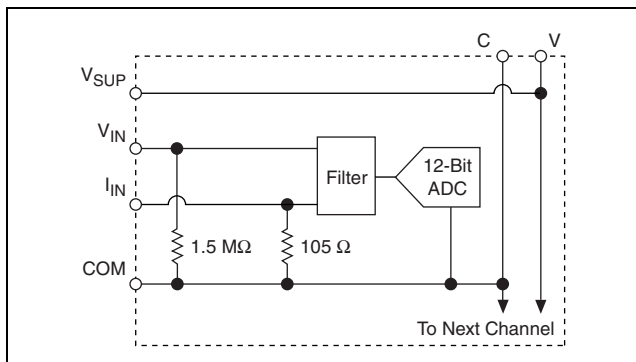

Figure 4. Input Circuitry on One Channel of the [c]FP-AIO-600

Voltage Inputs

The input ranges for voltage signals are ± 5 , ± 10 , ± 15 , ± 30 , 0–5, 0–10, 0–15, and 0–30 V. FieldPoint software accounts for the 20% overranging feature and shows the ranges accordingly.

Figure 5 shows how to connect a voltage source without an external power supply to one input channel of the [c]FP-AIO-600.

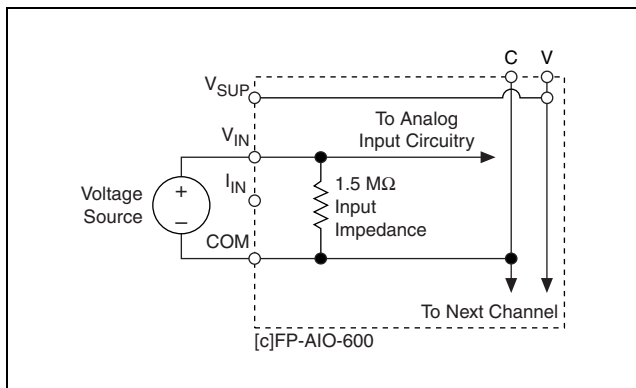

Figure 5. Voltage Input without an External Power Supply

Figure 6 shows how to connect a voltage source with an external power supply to one input channel of the [c]FP-AIO-600.

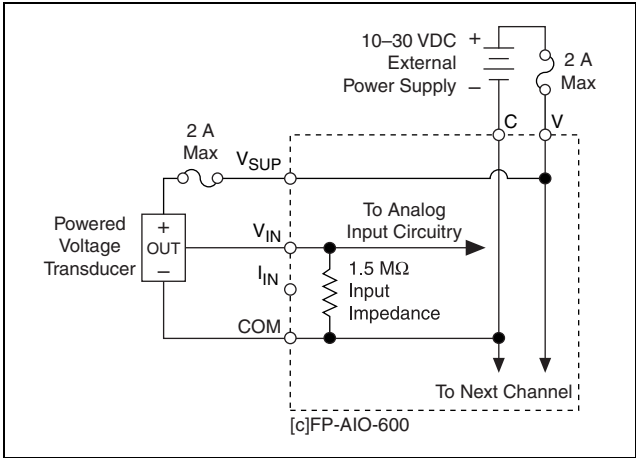

Figure 6. Voltage Input with an External Power Supply

Current Inputs

The input ranges for current sources are ± 20 , 0-20, and 4-20 mA. FieldPoint software accounts for the 20% overranging feature and shows the ranges accordingly. Figure 7 shows how to connect a current source without an external power supply to one input channel of the [c]FP-AIO-600.

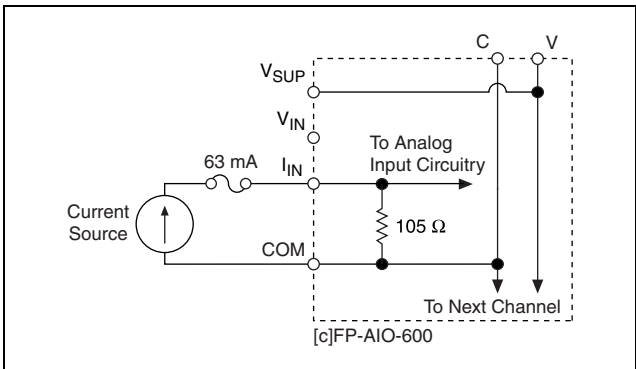

Figure 7. Current Input without an External Power Supply

Figure 8 shows how to connect a current source with an external power supply to one input channel of the [c]FP-AIO-600.

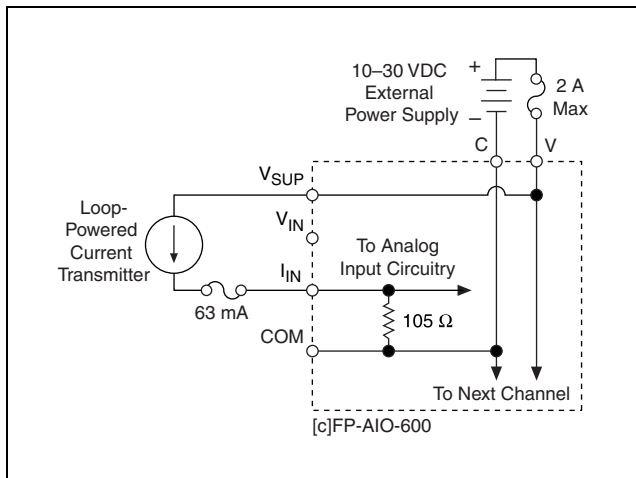

Figure 8. Current Input with an External Power Supply

Input Ranges

To prevent inaccurate readings, select an input range such that the signal you are measuring does not exceed either end of the range.

Overranging

The [c]FP-AIO-600 has an overranging feature that measures 20% beyond the nominal values of each range. For example, the actual measurement limit of the ± 5 V range is ± 6.0 V. The overranging feature enables the [c]FP-AIO-600 to compensate for field devices with span errors of up to 20% of full scale. Also, the overranging feature helps prevent errors caused by clipping.

Connecting the [c]FP-AIO-600 to a Load

The [c]FP-AIO-600 has four single-ended current output channels that *source* current from a 10-30 VDC, 125 mA external power supply. Sourcing current means that current flows out of the I_{OUT} terminal into the load. All four output channels and their common are isolated from the other modules in the FieldPoint system. The four output channels are not isolated from the four input channels.



Note Add a 2 A max fuse to any V_{SUP} terminal in use.

Figure 9 shows how to connect one output channel of the [c]FP-AIO-600 to a load.

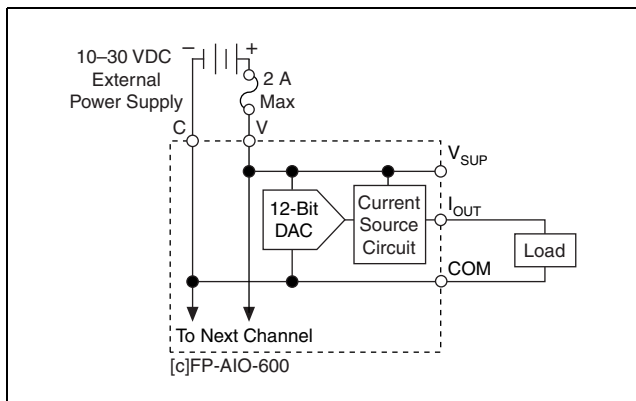

Figure 9. [c]FP-AIO-600 Analog Output Circuit

Output Ranges

You can configure each channel independently for an output range of 0–20 or 4–20 mA. The default range setting for each channel is 0–20 mA, with the power-up output set to 0 mA. The [c]FP-AIO-600 has overranging in each of these ranges, so the full-scale ranges available are 0–21 mA and 3.5–21 mA. Overranging enables the [c]FP-AIO-600 to compensate for span and offset errors in field devices.

Open-Loop Detection

Each channel has a monitoring circuit that compares the actual output current to the specified output current. If the [c]FP-AIO-600 cannot source the specified output current for one or more channels, the monitoring circuits turn on a red **STATUS** LED for each affected channel and report the error condition to the network module. Generally, the error condition is caused by an open current loop—either the load device or the external power supply is disconnected. However, the monitoring circuit also detects errors caused by load impedances that are too high and by external power supply voltages that are too low. For more information, refer to the *Specifications* section.

If the output of a [c]FP-AIO-600 channel is set to 0 mA, the monitoring circuit does not register an error condition because the [c]FP-AIO-600 can always source zero current, even to an open loop. Leave any unused and unwired channels in the default state to avoid error conditions.

Short-Circuit Protection

Each I_{OUT} terminal of the [c]FP-AIO-600 is protected against short circuits. One or more channel outputs can be short-circuited indefinitely without causing damage or improper operation to the channel, as long as the maximum loop supply does not exceed 30 VDC.

Status Indicators

The [c]FP-AIO-600 has two green status LEDs, **POWER** and **READY**. After you install the [c]FP-AIO-600 onto a terminal base or backplane and apply power to the connected network module, the green **POWER** indicator lights and the [c]FP-AIO-600 informs the network module of its presence. When the network module recognizes the [c]FP-AIO-600, it sends initial configuration information to the [c]FP-AIO-600. After the [c]FP-AIO-600 receives this initial information, the green **READY** indicator lights and the module is in normal operating mode.

In addition to the green **POWER** and **READY** indicators, each output channel has a red, numbered error status indicator. For more information, refer to the *Open-Loop Detection* section.

Upgrading the FieldPoint Firmware

You may need to upgrade the FieldPoint firmware when you add new I/O modules to the FieldPoint system. For information on determining which firmware you need and how to upgrade the firmware, go to ni.com/info and enter `fpmatrix`.

Isolation and Safety Guidelines



Caution Read the following information before attempting to connect the [c]FP-AIO-600 to any circuits that may contain hazardous voltages.

This section describes the isolation of the [c]FP-AIO-600 and its compliance with international safety standards. The field wiring connections are isolated from the backplane and the inter-module communication bus. The isolation barriers in the module provide 250 V_{rms} Measurement Category II continuous isolation, verified by 2,300 V_{rms}, 5 s dielectric withstand test. The [c]FP-AIO-600 provides *double insulation* (compliant with IEC 61010-1) for working voltages of 250 V_{rms}¹. Safety standards (such as those published by UL and IEC) require the use of double insulation between hazardous voltages and any human-accessible parts or circuits.

Never try to use any isolation product between human-accessible parts (such as DIN rails or monitoring stations) and circuits that can be at hazardous potentials under normal conditions, unless the product is specifically designed for such an application, as is the [c]FP-AIO-600.

Even though the [c]FP-AIO-600 is designed to handle applications with hazardous potentials, follow these guidelines to ensure a safe total system:

- There is no isolation between channels on the [c]FP-AIO-600. If a hazardous voltage is present on any channel, all channels are considered hazardous. Make sure that all other devices and circuits connected to the module are properly insulated from human contact.
- Do *not* share the external supply voltages (the V and C terminals) with other devices (including other FieldPoint devices), unless those devices are isolated from human contact.
- For Compact FieldPoint, you *must* connect the protective earth (PE) ground terminal on the cFP-BP-*x* backplane to the system safety ground. The backplane PE ground terminal has the following symbol stamped beside it: . Connect the backplane PE ground terminal to the system safety ground using 14 AWG (1.6 mm) wire with a ring lug. Use the 5/16 in. panhead screw shipped with the backplane to secure the ring lug to the backplane PE ground terminal.
- As with any hazardous voltage wiring, make sure that all wiring and connections meet applicable electrical codes and commonsense practices. Mount terminal bases and backplanes

¹ *Working voltage* is defined as the signal voltage plus the common-mode voltage. *Common-mode voltage* is the voltage of the module with respect to ground.

in an area, position, or cabinet that prevents accidental or unauthorized access to wiring that carries hazardous voltages.

- Do *not* use the [c]FP-AIO-600 as the only isolating barrier between human contact and working voltages higher than $250 V_{\text{rms}}$.
- Operate the [c]FP-AIO-600 only at or below Pollution Degree 2. Pollution Degree 2 means that only nonconductive pollution occurs in most cases. Occasionally, however, a temporary conductivity caused by condensation must be expected.
- Operate the [c]FP-AIO-600 at or below Measurement Category II. Measurement Category II is for measurements performed on circuits directly connected to the low-voltage installation. This category refers to local-level distribution, such as that provided by a standard wall outlet.

Safety Guidelines for Hazardous Locations

The cFP-AIO-600 is suitable for use in Class I, Division 2, Groups A, B, C, D, T4 hazardous locations; Class I, Zone 2, AEx nA IIC T4 and Ex nA IIC T4 hazardous locations; and nonhazardous locations only. Follow these guidelines if you are installing the cFP-AIO-600 in a potentially explosive environment. Failing to follow these guidelines may result in serious injury or death.



Caution Make sure that all products you use in hazardous locations are certified for such use. Refer to the product label or visit ni.com/certification, search by model number or product line, and click the appropriate link in the Certification column.



Caution Do *not* disconnect I/O-side wires or connectors unless power has been switched off or the area is known to be nonhazardous.



Caution Do *not* remove modules unless power has been switched off or the area is known to be nonhazardous.



Caution Substitution of components may impair suitability for Class I, Division 2.



Caution For Zone 2 applications, install the Compact FieldPoint system in an enclosure rated to at least IP 54 as defined by IEC 60529 and EN 60529.



Caution For Zone 2 applications, install a protection device across the external power supply and the COM terminal. The device must prevent the external power supply voltage from exceeding 42 V if there is a transient overvoltage condition.

Special Conditions for Hazardous Locations Use in Europe

The cFP-AIO-600 has been evaluated as EEx nC IIC T4 equipment under DEMKO Certificate No. 03 ATEX 0251502X. Each module is marked Ex II 3G and is suitable for use in Zone 2 hazardous locations.

Specifications

The following specifications are maximums for the range -40 to 70 °C unless otherwise noted. Specifications are subject to change without notice.

Input and Output Characteristics

Number of input channels.....	4
Number of output channels.....	4
ADC resolution	12 bits
Type of ADC.....	Successive approximation
DAC resolution	12 bits
Type of DAC	R-2R
Hardware update rate (all 8 channels).....	1.7 kHz (588 μ s period)

Voltage Inputs

Effective resolution	11.3 bits
Input impedance.....	1.5 M Ω
Signal input bandwidth (-3 dB).....	350 Hz
Voltage input accuracy by voltage input range	

Voltage Input Range (with Overranging)	Accuracy at 15 to 35 °C (% of Reading; % of Full Scale)	Accuracy at -40 to 70 °C (% of Reading; % of Full Scale)
0–6 V	$\pm 0.04\%$; $\pm 0.15\%$	$\pm 0.16\%$; $\pm 0.25\%$
0–12 V	$\pm 0.04\%$; $\pm 0.12\%$	$\pm 0.16\%$; $\pm 0.17\%$

Voltage Input Range (with Overranging)	Accuracy at 15 to 35 °C (% of Reading; % of Full Scale)	Accuracy at -40 to 70 °C (% of Reading; % of Full Scale)
0–18 V	±0.04%; ±0.10%	±0.16%; ±0.13%
0–36 V	±0.04%; ±0.09%	±0.16%; ±0.10%
±6 V	±0.04%; ±0.12%	±0.19%; ±0.17%
±12 V	±0.04%; ±0.10%	±0.19%; ±0.12%
±18 V	±0.04%; ±0.09%	±0.19%; ±0.11%
±36 V	±0.04%; ±0.08%	±0.19%; ±0.09%

Current Inputs

Effective resolution..... 11.3 bits

Input impedance..... 105 Ω

Overcurrent protection..... ±100 mA

Overvoltage protection ±10 V

Signal input bandwidth (-3 dB)..... 350 Hz

Current input accuracy by current input range

Current Input Range (with Overranging)	Accuracy at 15 to 35 °C (% of Reading; % of Full Scale)	Accuracy at -40 to 70 °C (% of Reading; % of Full Scale)
0–24 mA	±0.07%; ±0.08%	±0.29%; ±0.08%
3.5–24 mA	±0.07%; ±0.10%	±0.29%; ±0.10%
±24 mA	±0.07%; ±0.08%	±0.32%; ±0.08%

Current Outputs

Output range	0–20 or 4–20 mA, programmable (0–21 or 3.5–21 mA with overranging)
Type	Current source, external power required
External power supply	10–30 VDC, 125 mA for 4 output channels
Internal voltage drop	3 V
Resistive load	Up to 1 kΩ with 24 V power supply ¹
Protection	Short-circuit and open-circuit
Default power-up state	0 mA

Current output accuracy by current output range

Current Output Range (with Overranging)	Accuracy at 15 to 35 °C (% of Output Value; % of Full Scale)	Accuracy at –40 to 70 °C (% of Output Value; % of Full Scale)
0–21 mA	±0.03%; ±0.13%	±0.14%; ±0.2%
3.5–21 mA	±0.03%; ±0.16%	±0.14%; ±0.23%

Dynamic Characteristics

Hardware update rate	1,700 updates/s
Slew rate	0.4 mA/μs

Physical Characteristics

Indicators	Green POWER and READY indicators, and 4 red output indicators
------------------	---

Weight

FP-AIO-600	141 g (4.9 oz)
cFP-AIO-600	111 g (3.9 oz)

¹ Maximum load resistance = (Supply voltage – Internal voltage drop)/0.021 A

Power Requirements

Power from network module 600 mW

Isolation Voltage

Channel-to-ground isolation

Continuous 250 V_{rms}, Measurement
Category II

Dielectric withstand..... 2,300 V_{rms}, 5 s

Channel-to-channel isolation None

Environmental

FieldPoint modules are intended for indoor use only. For outdoor use, they must be mounted inside a sealed enclosure.

Operating temperature -40 to 70 °C

Storage temperature -55 to 85 °C

Humidity 10 to 90% RH,
noncondensing

Maximum altitude..... 2,000 m; at higher altitudes
the isolation voltage ratings
must be lowered

Pollution Degree 2

Shock and Vibration

These specifications apply only to the cFP-AIO-600.

NI recommends Compact FieldPoint if your application is subject to shock and vibration.

Operating vibration, random

(IEC 60068-2-64)..... 10–500 Hz, 5 g_{rms}

Operating vibration, sinusoidal

(IEC 60068-2-6)..... 10–500 Hz, 5 g

Operating shock

(IEC 60068-2-27)..... 50 g, 3 ms half sine,
18 shocks at 6 orientations;
30 g, 11 ms half sine,
18 shocks at 6 orientations

Safety

This product is designed to meet the requirements of the following standards of safety for electrical equipment for measurement, control, and laboratory use:

- IEC 61010-1, EN-61010-1
- UL 61010-1, CAN/CSA-C22.2 No. 61010-1



Note For UL and other safety certifications, refer to the product label or visit ni.com/certification, search by model number or product line, and click the appropriate link in the Certification column.

Electromagnetic Compatibility

This product is designed to meet the requirements of the following standards of EMC for electrical equipment for measurement, control, and laboratory use:

- EN 61326 EMC requirements; Industrial Immunity
- EN 55011 Emissions; Group 1, Class A
- CE, C-Tick, ICES, and FCC Part 15 Emissions; Class A



Note For EMC compliance, operate this device to product documentation.

CE Compliance

This product meets the essential requirements of applicable European Directives, as amended for CE marking, as follows:

- 73/23/EEC; Low-Voltage Directive (safety)
- 89/336/EEC; Electromagnetic Compatibility Directive (EMC)



Note Refer to the Declaration of Conformity (DoC) for this product for any additional regulatory compliance information. To obtain the DoC for this product, visit ni.com/certification, search by model number or product line, and click the appropriate link in the Certification column.

Waste Electrical and Electronic Equipment (WEEE)



EU Customers At the end of their life cycle, all products *must* be sent to a WEEE recycling center. For more information about WEEE recycling centers and National Instruments WEEE initiatives, visit ni.com/environment/weee.htm.

Mechanical Dimensions

Figure 10 shows the mechanical dimensions of the FP-AIO-600 installed on a terminal base. If you are using the cFP-AIO-600, refer to your Compact FieldPoint controller user manual for the dimensions and cabling clearance requirements of the Compact FieldPoint system.

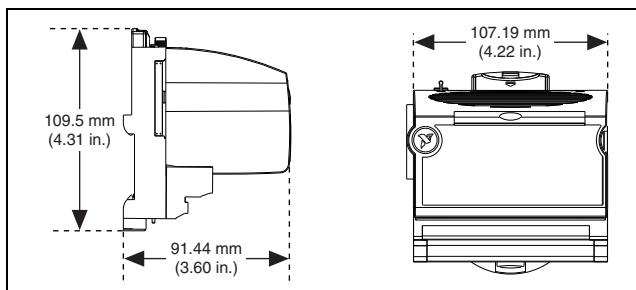

Figure 10. FP-AIO-600 Mechanical Dimensions

Where to Go for Support

For more information about setting up the FieldPoint system, refer to these National Instruments documents:

- FieldPoint network module user manual
- Other FieldPoint I/O module operating instructions
- FieldPoint terminal base and connector block operating instructions

Go to ni.com/support for the most current manuals, examples, and troubleshooting information.

For telephone support in the United States, create your service request at ni.com/ask and follow the calling instructions or dial 512 795 8248. For telephone support outside the United States, contact your local branch office:

Australia 1800 300 800, Austria 43 0 662 45 79 90 0,
Belgium 32 0 2 757 00 20, Brazil 55 11 3262 3599,
Canada 800 433 3488, China 86 21 6555 7838,
Czech Republic 420 224 235 774, Denmark 45 45 76 26 00,
Finland 385 0 9 725 725 11, France 33 0 1 48 14 24 24,
Germany 49 0 89 741 31 30, India 91 80 41190000,
Israel 972 0 3 6393737, Italy 39 02 413091,
Japan 81 3 5472 2970, Korea 82 02 3451 3400,
Lebanon 961 0 1 33 28 28, Malaysia 1800 887710,
Mexico 01 800 010 0793, Netherlands 31 0 348 433 466,
New Zealand 0800 553 322, Norway 47 0 66 90 76 60,
Poland 48 22 3390150, Portugal 351 210 311 210,
Russia 7 095 783 68 51, Singapore 1800 226 5886,
Slovenia 386 3 425 4200, South Africa 27 0 11 805 8197,
Spain 34 91 640 0085, Sweden 46 0 8 587 895 00,
Switzerland 41 56 200 51 51, Taiwan 886 02 2377 2222,
Thailand 662 278 6777, United Kingdom 44 0 1635 523545

National Instruments, NI, ni.com, and LabVIEW are trademarks of National Instruments Corporation. Refer to the *Terms of Use* section on ni.com/legal for more information about National Instruments trademarks. Other product and company names mentioned herein are trademarks or trade names of their respective companies. For patents covering National Instruments products, refer to the appropriate location: **Help»Patents** in your software, the `patents.txt` file on your CD, or ni.com/patents.

© 2003–2009 National Instruments Corp. All rights reserved.