

COMPREHENSIVE SERVICES

We offer competitive repair and calibration services, as well as easily accessible documentation and free downloadable resources.

SELL YOUR SURPLUS

We buy new, used, decommissioned, and surplus parts from every NI series. We work out the best solution to suit your individual needs.

 Sell For Cash  Get Credit  Receive a Trade-In Deal

OBSOLETE NI HARDWARE IN STOCK & READY TO SHIP

We stock **New**, **New Surplus**, **Refurbished**, and **Reconditioned** NI Hardware.



Bridging the gap between the manufacturer and your legacy test system.

 1-800-915-6216

 www.apexwaves.com

 sales@apexwaves.com

All trademarks, brands, and brand names are the property of their respective owners.

Request a Quote

 **CLICK HERE**

FP-AO-210

FP-AO-210 AND cFP-AO-210

Eight-Channel 10 V Analog Output Module

These operating instructions describe how to install and use the National Instruments FP-AO-210 and cFP-AO-210 analog output modules (referred to inclusively as the [c]FP-AO-210). For information about configuring and accessing the [c]FP-AO-210 over a network, refer to the user manual for the FieldPoint network module you are using.

Features

The [c]FP-AO-210 is a FieldPoint analog output module with the following features:

- Eight 0–10 V outputs
- 12-bit resolution
- Sources 1 mA per channel (up to 10 mA with optional external power supply)
- Overcurrent indicators
- 2,300 V_{rms} transient overvoltage protection between the inter-module communication bus and the I/O channels
- –40 to 70 °C operation
- Hot plug-and-play

FieldPoint™, National Instruments™, NI™, and ni.com™ are trademarks of National Instruments Corporation. Product and company names mentioned herein are trademarks or trade names of their respective companies. For patents covering National Instruments products, refer to the appropriate location: **Help»Patents** in your software, the `patents.txt` file on your CD, or `ni.com/patents`.

Installing the FP-AO-210

The FP-AO-210 mounts on a FieldPoint terminal base (FP-TB-*x*). Hot plug-and-play enables you to install the FP-AO-210 onto a powered terminal base without disturbing the operation of other modules or terminal bases. The FP-AO-210 receives operating power from the terminal base. Current loop power is externally supplied.

To install the FP-AO-210, refer to Figure 1 and complete the following steps:

1. Slide the terminal base key to either position X (used for any module) or position 2 (used for the FP-AO-210 module).
2. Align the FP-AO-210 alignment slots with the guide rails on the terminal base.
3. Press firmly to seat the FP-AO-210 in the terminal base. The terminal base latch locks the FP-AO-210 into place when it is firmly seated.
4. Connect a current loop supply for the outputs to the V and C terminals of the terminal base.

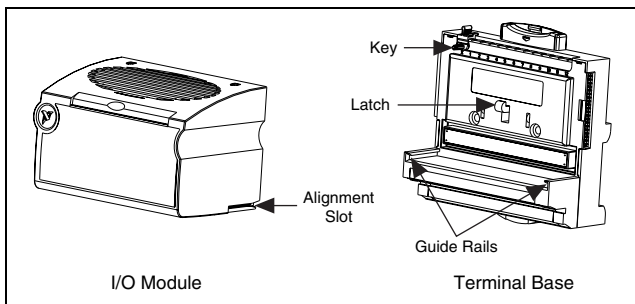

Figure 1. Installing the FP-AO-210

Installing the cFP-AO-210

The cFP-AO-210 mounts on a Compact FieldPoint backplane (cFP-BP-*x*). Hot plug-and-play enables you to install the cFP-AO-210 onto a powered backplane without disturbing the operation of other modules or connector blocks. The cFP-AO-210 receives operating power from the backplane.

To install the cFP-AO-210, refer to Figure 2 and complete the following steps:

1. Align the captive screws on the cFP-AO-210 with the holes on the backplane. The alignment keys on the cFP-AO-210 prevent backward insertion.
2. Press firmly to seat the cFP-AO-210 on the backplane.
3. Using a number 2 Phillips screwdriver with a shank of at least 64 mm (2.5 in.) length, tighten the captive screws to 1.1 N · m (10 lb · in.) of torque. The nylon coating on the screws prevents them from loosening.

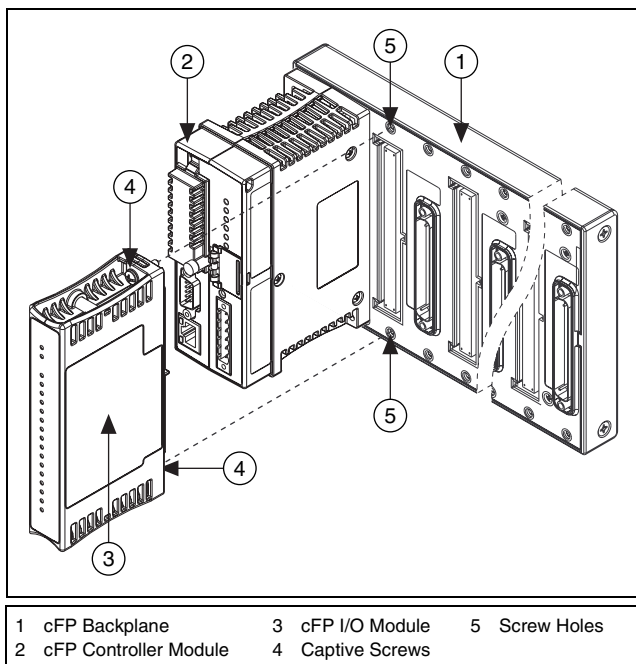

Figure 2. Installing the cFP-AO-210

Wiring the [c]FP-AO-210

The FP-TB- x terminal base provides connections for the eight output channels of the FP-AO-210. The cFP-CB- x connector block provides the same connections for the cFP-AO-210.

Table 1 lists the terminal assignments for the signals associated with each channel.

Table 1. Terminal Assignments

Channel	Terminal Numbers		
	V_{out}	COM	V_{sup}
0	1	2, 18	17
1	3	4, 20	19
2	5	6, 22	21
3	7	8, 24	23
4	9	10, 26	25
5	11	12, 28	27
6	13	14, 30	29
7	15	16, 32	31

Each channel has an output terminal, V_{out} ; a common terminal, COM; and a supply terminal, V_{sup} . The COM terminals of all the channels are connected internally to each other and to the C terminals, and the V_{sup} terminals are all connected to each other and to the V terminals. Refer to the sections that follow for detailed wiring instructions.

Sourcing and Sinking Current

Each channel of the [c]FP-AO-210 can source or sink 1 mA without an external supply. Figure 3 shows how to connect two channels of the [c]FP-AO-210 to loads that require up to 1 mA.

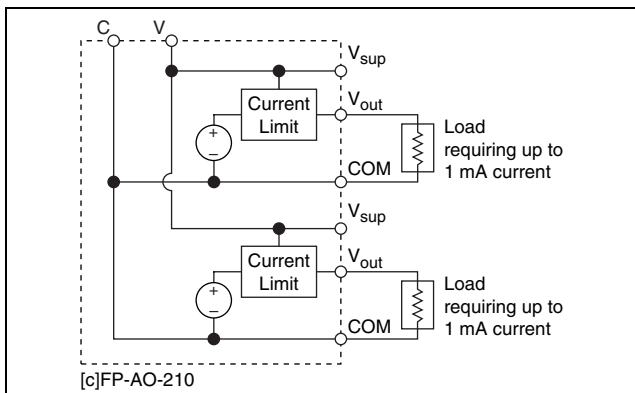

Figure 3. Two Loads without External Supply

Figure 4 shows how to connect two channels of the [c]FP-AO-210 to loads sinking up to 10 mA of current.

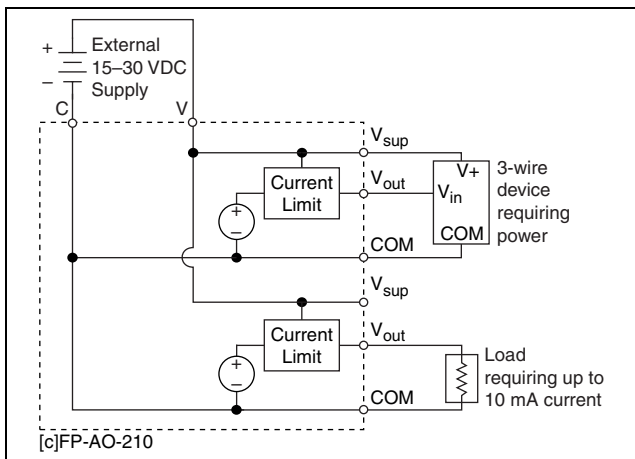

Figure 4. Two Loads with External Supply

Voltage Output Circuit

The [c]FP-AO-210 output circuit is a current-limited voltage source capable of sourcing (flowing out of the V_{out} terminal to the load) or sinking (flowing into the V_{out} terminal from the load) current. The [c]FP-AO-210 internal circuitry limits the magnitude of this current to 1 mA. You can obtain up to 10 mA sourcing current by adding an optional external power supply. The [c]FP-AO-210 operates with an external power supply from 15 to 30 VDC.

The [c]FP-AO-210 updates the output channels as new values are sent to it by the network module. The time it takes to respond to a change on a single channel is between 3 and 6 ms. The response time to changes on all eight channels is 24 to 27 ms.

Output Range

The [c]FP-AO-210 has an output range of 0–10 V. The factory default power-up setting for each channel is 0 V. The [c]FP-AO-210 has overranging of 0.2 V. Therefore, the actual full-scale range of each channel is 0–10.2 V. This extended range enables the [c]FP-AO-210 to compensate for span and offset errors in field devices.

Current Limit Detection

Each channel on the [c]FP-AO-210 has a monitoring circuit that detects the amount of current flowing into (sinking) or out of (sourcing) the channel. If this value exceeds the maximum allowable (1 mA with no external supply; 10 mA with external supply), the circuit lights a red **STATUS** indicator for each affected channel, reports the error to the network module, and adjusts the output voltage so that only the maximum allowed current flows. The error is reported before the output is adjusted. The indicator may start to light dimly as the limit is approached.

Overvoltage Protection

Each [c]FP-AO-210 output terminal V_{out} is protected against damage resulting from accidental connection to the output terminals of other channels. Also, you can connect one or more channel output terminals directly to an external voltage source indefinitely without causing damage or improper operation of other channels, as long as the maximum voltage does not exceed the range of –10 to 20 VDC referenced to the C and COM terminals.

Status Indicators

Figure 5 shows the [c]FP-AO-210 status indicators.

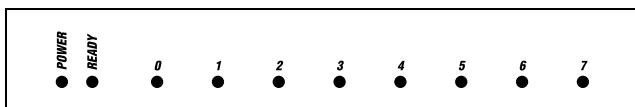

Figure 5. Status Indicators

The [c]FP-AO-210 has two green status LEDs, **POWER** and **READY**. After you insert the [c]FP-AO-210 into a terminal base or backplane and apply power to the connected network module, the green **POWER** indicator lights and the [c]FP-AO-210 informs the network module of its presence. When the network module recognizes the [c]FP-AO-210, it sends initial configuration information to the [c]FP-AO-210. After receiving this initial information, the green **READY** indicator lights and the [c]FP-AO-210 is in normal operating mode.

In addition to the green **POWER** and **READY** indicators, each channel has a red, numbered error status indicator. For more information, refer to the [Current Limit Detection](#) section.

Upgrading the FieldPoint Firmware

You may need to upgrade the FieldPoint firmware when you add new I/O modules to the FieldPoint system. For information on determining which firmware you need and how to upgrade, go to ni.com/info and enter *fpmatrix*.

Isolation and Safety Guidelines



Caution Read the following information before attempting to connect the [c]FP-AO-210 to any circuits that may contain hazardous voltages.

This section describes the isolation of the [c]FP-AO-210 and its compliance with international safety standards. The field wiring connections are isolated from the backplane and the inter-module communication bus. The isolation is provided by the module, which has optical and galvanic isolation barriers designed and tested to protect against transient fault voltages of up to 2,300 V_{rms}.

Follow these guidelines to ensure a safe total system:

- The [c]FP-AO-210 has a safety isolation barrier between the I/O channels and the inter-module communication bus. There is no isolation between channels unless otherwise noted. If any of the channels on a module are wired at a hazardous potential, make sure that all other devices or circuits connected to that module are properly insulated from human contact.
- Do *not* share the external supply voltages (the V and C terminals) with other devices (including other FieldPoint devices), unless those devices are isolated from human contact.
- For Compact FieldPoint, you *must* connect the protective earth (PE) ground terminal on the cFP-BP-*x* backplane to the system safety ground. The backplane PE ground terminal has the following symbol stamped beside it: \oplus . Connect the backplane PE ground terminal to the system safety ground using 14 AWG (1.6 mm) wire with a ring lug. Use the 5/16 in. panhead screw shipped with the backplane to secure the ring lug to the backplane PE ground terminal.
- As with any hazardous voltage wiring, make sure that all wiring and connections meet applicable electrical codes and commonsense practices. Mount terminal bases and backplanes in an area, position, or cabinet that prevents accidental or unauthorized access to wiring that carries hazardous voltages.
- Operate the [c]FP-AO-210 only at or below Pollution Degree 2. Pollution Degree 2 means that only nonconductive pollution occurs in most cases. Occasionally, however, a temporary conductivity caused by condensation must be expected.
- Refer to the FieldPoint product label for regulatory certification under hazardous location standards. If the FieldPoint product is not certified for operation in hazardous locations, do not operate it in an explosive atmosphere or where there may be flammable gases or fumes.

Specifications

These specifications are typical for the range -40 to 70 °C unless otherwise noted.

Output Characteristics

Number of channels	8 single-ended
Resolution	12 bits, 1 in 4,096 (~2.5 mV/bit)

Voltage Output

Output range	0 to 10 V (0 to 10.2 V with overranging)
Type	Voltage source, external power optional
External power.....	15 to 30 VDC
Current drive	1 mA sourcing or sinking, 10 mA sourcing with external power supply
Overvoltage protection	-10 to 20 V
Default power-up state.....	0 V

Accuracy

Gain error.....	0.2% typical 0.4% maximum
Offset error.....	4 mV typical 14 mV maximum
Monotonicity ¹	Guaranteed over operating temperature range
Offset temperature coefficient	70 $\mu\text{V}/^\circ\text{C}$
Gain temperature coefficient	20 ppm/ $^\circ\text{C}$

Dynamic Characteristics

Max conversion rate.....	200 updates/s
Slew rate	0.5 V/ μs

Physical Characteristics

Indicators	Green POWER and READY indicators, 8 red current limit indicators
------------------	--

Weight

FP-AO-210	145 g (5.2 oz)
cFP-AO-210	115 g (4.1 oz)

¹ A characteristic of a DAC in which the analog output always increases as the value of the digital code input to it increases.

Power Requirements

Power from network module 600 mW

Isolation Voltage

Channel-to-channel isolation No isolation between channels

Transient overvoltage 2,300 V_{rms}

Environmental

FieldPoint modules are intended for indoor use only. For outdoor use, they must be mounted inside a sealed enclosure.

Operating temperature -40 to 70 °C

Storage temperature -55 to 100 °C

Humidity 10 to 90% RH, noncondensing

Maximum altitude 2,000 m

Pollution Degree 2

Shock and Vibration

Operating shock (IEC 68-2-27)

cFP-AO-210 50 g, 3 ms half sine, 3 shocks;
30 g, 11 ms half sine,
3 shocks

Operating vibration, random (IEC 60068-2-34)

FP-AO-210 10–500 Hz, 2.2 g_{rms}

cFP-AO-210 10–500 Hz, 5 g_{rms}

Operating vibration, sinusoidal (IEC 60068-2-6)

[c]FP-AO-210 10–500 Hz, 5 g

Safety

The [c]FP-AO-210 is designed to meet the requirements of the following standards for safety and electrical equipment for measurement, control, and laboratory use.

- EN 61010-1, IEC 61010-1
- UL 3121-1
- CAN/CSA C22.2 No. 1010.1

For certifications under regulatory standards, including hazardous location standards, refer to the product label or to ni.com.

Electromagnetic Compatibility

CE, C-Tick, and FCC Part 15 (Class A) Compliant

Electromagnetic emissions EN 55011 Class A at 10 m
FCC Part 15A above 1 GHz

Electromagnetic immunity..... Evaluated to EN 61326:
1997/A1: 1998, Table 1



Note For full EMC compliance, you must operate this device with shielded cabling. See the Declaration of Conformity (DoC) for this product for any additional regulatory compliance information. To obtain the DoC for this product, click **Declaration of Conformity** at ni.com/hardref.nsf/.

Mechanical Dimensions

Figure 6 shows the mechanical dimensions of the FP-AO-210 installed on a terminal base. Dimensions are given in millimeters [inches]. If you are using the cFP-AO-210, refer to the Compact FieldPoint controller user manual for the dimensions and cabling clearance requirements of the Compact FieldPoint system.

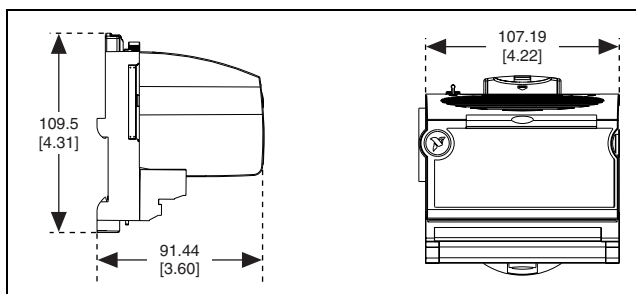

Figure 6. FP-AO-210 Mechanical Dimensions

Where to Go for Support

For more information about setting up the FieldPoint system, refer to the following National Instruments documents:

- FieldPoint network module user manual
- Other FieldPoint I/O module operating instructions
- FieldPoint terminal base operating instructions

Go to ni.com/support for the most current manuals, examples, and troubleshooting information.

For telephone support in the United States, create your service request at ni.com/ask and follow the calling instructions or dial 512 795 8248. For telephone support outside the United States, contact your local branch office:

Australia 03 9879 5166, Austria 0662 45 79 90 0,
Belgium 02 757 00 20, Brazil 55 11 3262 3599,
Canada (Calgary) 403 274 9391,
Canada (Montreal) 514 288 5722,
Canada (Ottawa) 613 233 5949, Canada (Québec) 514 694 8521,
Canada (Toronto) 905 785 0085, China 86 21 6555 7838,
Czech Republic 02 2423 5774, Denmark 45 76 26 00,
Finland 09 725 725 11, France 01 48 14 24 24,
Germany 089 741 31 30, Greece 01 42 96 427,
Hong Kong 2645 3186, India 91 80 4190000,
Israel 03 6393737, Italy 02 413091, Japan 03 5472 2970,
Korea 02 3451 3400, Malaysia 603 9596711,
Mexico 001 800 010 0793, Netherlands 0348 433466,
New Zealand 09 914 0488, Norway 32 27 73 00,
Poland 22 3390 150, Portugal 210 311 210, Russia 095 238 7139,
Singapore 65 6 226 5886, Slovenia 3 425 4200,
South Africa 11 805 8197, Spain 91 640 0085,
Sweden 08 587 895 00, Switzerland 056 200 51 51,
Taiwan 02 2528 7227, United Kingdom 01635 523545



323347A-01

Oct02