

COMPREHENSIVE SERVICES

We offer competitive repair and calibration services, as well as easily accessible documentation and free downloadable resources.

SELL YOUR SURPLUS

We buy new, used, decommissioned, and surplus parts from every NI series. We work out the best solution to suit your individual needs.

 Sell For Cash  Get Credit  Receive a Trade-In Deal

OBSOLETE NI HARDWARE IN STOCK & READY TO SHIP

We stock **New**, **New Surplus**, **Refurbished**, and **Reconditioned** NI Hardware.



Bridging the gap between the manufacturer and your legacy test system.

 1-800-915-6216

 www.apexwaves.com

 sales@apexwaves.com

All trademarks, brands, and brand names are the property of their respective owners.

Request a Quote

 **CLICK HERE**

FP-DO-403

FP-DO-403



16-Channel, 5 to 30 V Sinking Discrete Output Module

These operating instructions describe the installation, features, and characteristics of the FP-DO-403. For details on configuring and accessing the FP-DO-403 over a network, refer to the user manual for the particular FieldPoint network module you are using with the FP-DO-403.

Features

The FP-DO-403 is a FieldPoint discrete output module with the following features:

- 16 discrete output channels
- Sinking outputs supply 2 A per channel, 16 A² per module
- Compatible with voltages from 5 to 30 VDC
- On/Off LED indicators
- Hot plug and play operation
- 3,000 V input to output isolation
- Double insulated for 250 V safe working voltage
- -40 to +70 °C operation

Installation

The FP-DO-403 mounts on a FieldPoint terminal base (FP-TB-xx) unit. The hot plug and play operation of the FP-DO-403 allows you to install it onto a powered terminal base without disturbing the operation of other modules or terminal bases. The FP-DO-403 receives operating power from the terminal base.

FieldPoint™ is a trademark of National Instruments Corporation. Product and company names mentioned herein are trademarks or trade names of their respective companies.

To install the FP-DO-403, refer to Figure 1 and follow these steps:

1. Slide the terminal base key to either position X (used for any module) or position 6 (used for the FP-DO-403 module).
2. Align the FP-DO-403 alignment slots with the guide rails on the terminal base.
3. Press firmly to seat the FP-DO-403 on the terminal base. The terminal base latch locks the FP-DO-403 into place when it is firmly seated.

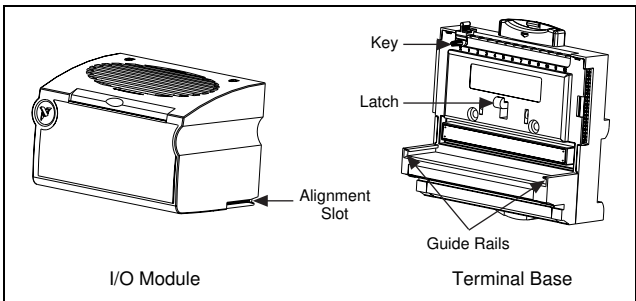

Figure 1. Module Installation Diagram

Field Wiring

The terminal base provides connections for each of the sixteen output channels and an external supply to power field devices. Although the external supply is not needed for the internal operation of the FP-DO-403, the outputs sink current from this external supply. You may connect an external supply to power field devices by connecting to the V and C terminals of the terminal base. Each channel has one output terminal, V_{out} ; a common terminal, COM (internally connected to the C terminal); and a supply terminal, V_{sup} (internally connected to the V terminal). If the total current supplied by the channels of the FP-DO-403 is more than 5 A, route the external supply to the V_{sup} and COM terminals of individual channels. Otherwise, the external supply may simply be connected to the V and C terminals. Figures 2a and 2b show examples of basic wiring connections.

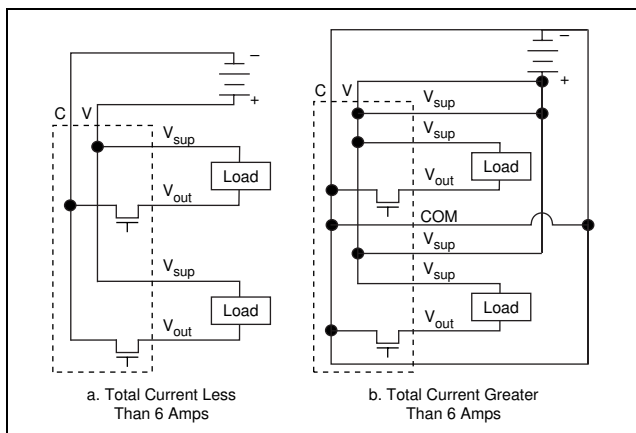

Figure 2. Basic Field Connections (Two Channels Shown)

Table 1 lists the terminal assignments for the signals of each channel.

Table 1. Terminal Assignments

| Channel | Terminal Numbers | | |
|---------|------------------|------------------|-----|
| | V _{out} | V _{sup} | COM |
| 0 | 1 | 17 | 18 |
| 1 | 2 | 17 | 18 |
| 2 | 3 | 19 | 20 |
| 3 | 4 | 19 | 20 |
| 4 | 5 | 21 | 22 |
| 5 | 6 | 21 | 22 |
| 6 | 7 | 23 | 24 |
| 7 | 8 | 23 | 24 |

| Channel | Terminal Numbers | | |
|---------|------------------|------------------|-----|
| | V _{out} | V _{sup} | COM |
| 8 | 9 | 25 | 26 |
| 9 | 10 | 25 | 26 |
| 10 | 11 | 27 | 28 |
| 11 | 12 | 27 | 28 |
| 12 | 13 | 29 | 30 |
| 13 | 14 | 29 | 30 |
| 14 | 15 | 31 | 32 |
| 15 | 16 | 31 | 32 |

Discrete Output Circuit

The discrete outputs of the FP-DO-403 consist of optically-isolated sinking outputs. In the ON state, a transistor is turned on between the output (V_{out}) terminal and the external supply (the C and COM terminals). In the OFF state, this transistor is turned off, allowing only a small leakage current to flow. Choose the

impedance of the loads driven by the output channels so that the current supplied by any one channel in the ON state is no more than 2 A, and the total current supplied by all channels at any one time is no more than 16 A².

Use the following formula to ensure the total current per module is not exceeded. Square the current of each channel and add them all together. The result must be equal to or less than 16 A². For example, three channels with 2 A and four channels with 1 A $\leq 16 \text{ A}^2$ would be as follows: $(2\text{A})^2 + (2\text{A})^2 + (2\text{A})^2 + (1\text{A})^2 + (1\text{A})^2 + (1\text{A})^2 + (1\text{A})^2 \leq 16 \text{ A}^2$.

The outputs must *not* be short circuited to the potential of the V or V_{sup} terminals (the positive voltage of the external supply). Such a short circuit would cause many amps of current to flow through an output and would damage the output. Check all wiring carefully before applying power.

In the ON state, there is an effective resistance of 0.12 Ω between the output (V_{out}) and the supply voltage (the C and COM terminals). This resistance causes a voltage drop between the external supply voltage and the output voltage. For example, if the external supply voltage is 5 V and the output current is 1 A, the output voltage is 4.88 V: $[5 \text{ V} - (1 \text{ A} \times 0.12 \Omega) = 4.88 \text{ V}]$.

Figure 3 shows the diagram of one channel's discrete output circuit.

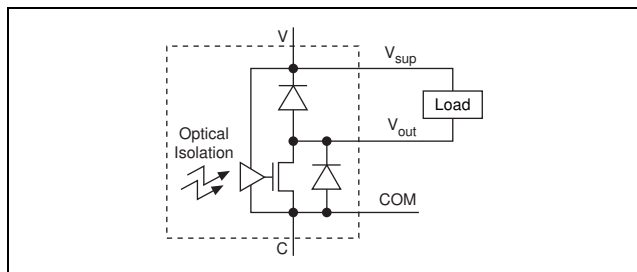

Figure 3. Discrete Output Circuit

Status Indicators

Figure 4 shows the module label and status indicators. You can remove the insertable label to see wiring diagrams for the output channels.

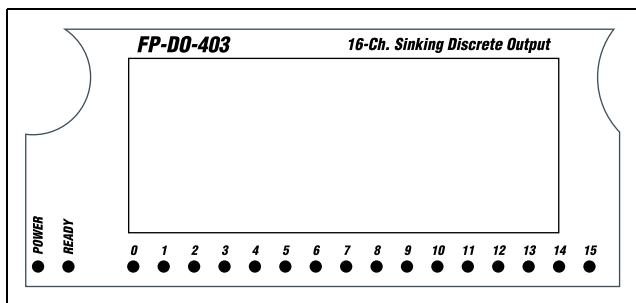

Figure 4. Status Indicators and Module Label

After the module has been inserted into a terminal base (and power is applied), the green **POWER** indicator turns on and the FP-DO-403 informs the network module of its presence. When the network module recognizes the FP-DO-403, it sends initial configuration information to the FP-DO-403. After receiving this initial information, the green **READY** indicator turns on and the FP-DO-403 is in its normal operating mode. In addition to the green **POWER** and **READY** indicators, each channel has a numbered, green, output state indicator which lights when the channel is in the ON state.

Isolation and Safety Guidelines



Caution Read the following information before attempting to connect *any* circuits which may contain hazardous voltages to the FP-DO-403.

This section describes the isolation of the FP-DO-403 and its compliance with international safety standards. The outputs are isolated from the backplane provided by the terminal base with an optical isolation barrier designed and tested to provide protection against fault voltages of up to 3000 Vrms. In addition, the FP-DO-403 provides *double insulation* (compliant to UL and IEC safety standards) for working common mode voltages of 250 Vrms. Safety standards (such as those published by UL and

IEC) require the use of double insulation between hazardous voltages and any human-accessible parts or circuits. You should *never* attempt to use any isolation product between human accessible parts (such as DIN rails or monitoring stations) and circuits which may be at hazardous potentials under normal conditions, unless the product is specifically designed (as the FP-DO-403 is) for such an application.

Even when a product like the FP-DO-403 is used in applications with hazardous potentials, follow these guidelines to ensure a safe total system.

- The *safety* isolation of the FP-DO-403 is from input to output, *not* between channels on the same module. If any of the channels on a module are wired at a hazardous potential, ensure that all other devices or circuits connected to that module are properly insulated from human contact.
- Do *not* share the external supply voltages (V and C on the terminal base) with other devices (including other FieldPoint devices) unless those devices are also isolated from human contact.
- As with any hazardous voltage wiring, ensure that all wiring and connections meet with applicable electrical codes or common sense practices. Mount terminal bases in an area, position, or cabinet that prevents accidental or unauthorized access to wiring with hazardous voltages.
- The isolation of the FP-DO-403 is certified as double insulated for normal operating voltages of 250 Vrms. Do *not* use the FP-DO-403 as the sole isolating barrier between human contact and working voltages of more than 250 Vrms.

Specifications

These specifications are typical for the range -40 to $+70$ °C unless otherwise noted.

Input Characteristics

| | |
|--------------------------|---|
| Number of channels | 16 |
| Output type | Sinking |
| Voltage range | 5 to 30 VDC |
| Output impedance | 0.12 Ω (0.12 volts drop at 1 A) |

Maximum output current 2 A per channel,
16 A² per module



Note Sum of output currents squared must be less than 16 A². (For example, 1 A on 16 channels or 2 A on four channels).

Maximum OFF state leakage 50 μ A

Output delay times 50 μ s

Isolation 3,000 Vrms

Safety isolation, working voltage 250 Vrms, designed per IEC 1010 as double insulated

Physical

Indicators Green **POWER** and **READY** indicators, 16 green output state indicators

Weight 140 g (4.8 oz.)

Power Requirements

Power from network module 600 mW

Environment

Operating temperature -40 to +70 °C

Storage temperature -55 to +100 °C

Relative humidity 5% to 90% non-condensing

CE Mark Compliance

This product meets applicable EU directive(s) as follows:

Safety isolation EN 61010 (double insulation for 250 Vrms working isolation, installation category II)

EMC directive

Immunity EN 50082-1:1994

Emissions EN 55011:1991 Group I Class A at 10 meters

Mechanical Dimensions

Figure 5 shows the mechanical dimensions of the FP-DO-403. Dimensions are given in inches [millimeters].

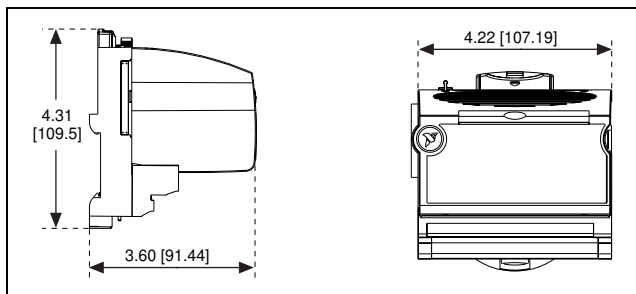

Figure 5. Mechanical Dimensions



322302B-01

Jun99