

## COMPREHENSIVE SERVICES

We offer competitive repair and calibration services, as well as easily accessible documentation and free downloadable resources.

## SELL YOUR SURPLUS

We buy new, used, decommissioned, and surplus parts from every NI series. We work out the best solution to suit your individual needs.

 Sell For Cash    Get Credit    Receive a Trade-In Deal

## OBSOLETE NI HARDWARE IN STOCK & READY TO SHIP

We stock **New**, **New Surplus**, **Refurbished**, and **Reconditioned** NI Hardware.



*Bridging the gap between the manufacturer and your legacy test system.*

 1-800-915-6216

 [www.apexwaves.com](http://www.apexwaves.com)

 [sales@apexwaves.com](mailto:sales@apexwaves.com)

*All trademarks, brands, and brand names are the property of their respective owners.*

**Request a Quote**

 **CLICK HERE**

**FP-RLY-422**

**FieldPoint™**

# FP-RLY-422

## 4-Channel, SPDT Relay Module

These operating instructions describe the installation, features, and characteristics of the FP-RLY-422. For details on configuring and accessing the FP-RLY-422 over a network, refer to the user manual for the particular FieldPoint network module you are using with the FP-RLY-422.

## Features

---

The FP-RLY-422 is a FieldPoint relay output module with the following features:

- Four Single-Pole Double-Throw (SPDT) relay channels
- Switching capacity 3 A at 35 VDC or 250 VAC
- On/Off LED indicators
- Hot plug and play operation
- 3,000 V input to output isolation
- Double insulated for 250 V safe working voltage
- -40 to +70 °C operation

## Installation

---

The FP-RLY-422 mounts on a FieldPoint terminal base (FP-TB-xx) unit. The hot plug and play operation of the FP-RLY-422 allows you to install it onto a powered terminal base without disturbing the operation of other modules or terminal bases. The FP-RLY-422 receives operating power from the terminal base.

To install the FP-RLY-422, refer to Figure 1 and follow these steps:

1. Slide the terminal base key to either position X (used for any module) or position 7 (used for the FP-RLY-422 module).
2. Align the FP-RLY-422 alignment slots with the guide rails on the terminal base.
3. Press firmly to seat the FP-RLY-422 on the terminal base. The terminal base latch locks the FP-RLY-422 into place when it is firmly seated.

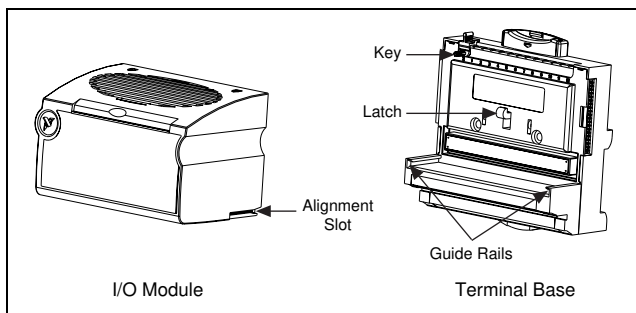

**Figure 1.** Module Installation Diagram

## Field Wiring

The terminal base has connections for each of the four relay channels and an external supply to power field devices. Each relay channel of the FP-RLY-422 has four terminals: one N.Open (Normally Open), two I.Com (Isolated Common), and one N.Closed (Normally Closed). The external supply is not needed for the internal operation of the FP-RLY-422; however, you may connect an external supply to power field devices by connecting to the V and C terminals of the terminal base. If you connect an external supply to the V and C terminals, the total current supplied cannot exceed 5 A.

Table 1 lists the terminal assignments for the signals of each channel.

**Table 1.** Terminal Assignments

Channel	Terminal Numbers				
	N.Open	I.Com	N.Closed	V <sub>SUP</sub>	COM
0	1	2,3	4	17	18
				19	20
1	5	6,7	8	21	22
				23	24
2	9	10,11	12	25	26
				27	28
3	13	14,15	16	29	30
				31	32

Figures 2a and 2b show examples of basic wiring connections.

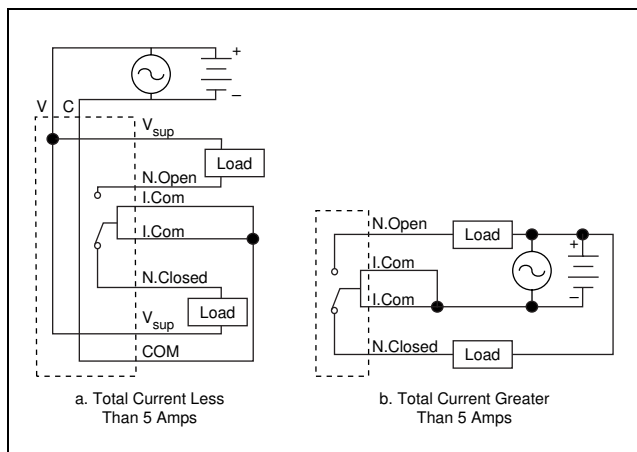

**Figure 2.** Basic Field Connection

# Relay Output Circuit

The outputs of the FP-RLY-422 consist of four independent Form C electromechanical relays. The relays are break-before-make, but only if you do not exceed the specified relay operation speed. All relays remain in their power-up state or OFF state (N.Closed connected to I.Com) until the relay (Channel) is turned on. This will break the N.Closed–I.Com connection and connect I.Com to N.Open. Choose the impedance of the loads so that the current switched by any one channel is no more than 3 A. Each relay can be controlled separately without affecting the others, or all relays can change states at the same time.

There is an effective resistance of 100 m $\Omega$  between I.Com and N.Closed or N.Open. This resistance will cause a voltage drop. For example, if the current is 3 A, the voltage drop across the I.Com and N.Closed or N.Open terminals is 0.3 V.

Figure 3 shows the diagram of one channel's relay output circuit.

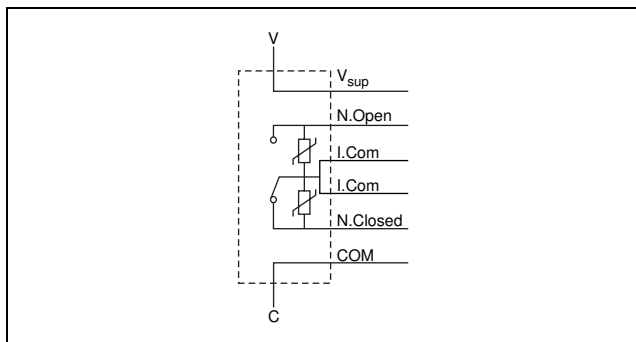

**Figure 3.** Relay Output Circuit

The maximum switching capacity of each relay is 3 A up to 250 VAC or 35 VDC. To switch greater DC voltages, refer to Figure 4.

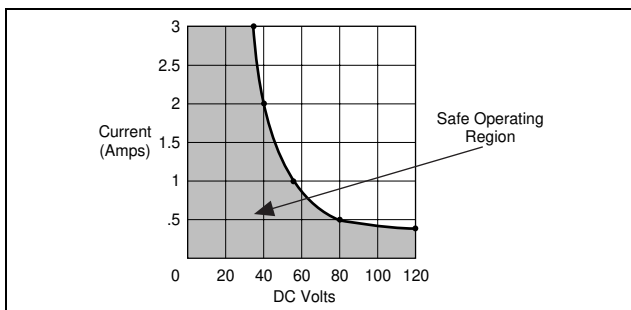

**Figure 4.** Maximum Current vs. DC Volts

## Contact Protection for Inductive Loads

When inductive loads are connected to the relays, a large counter-electromotive force may occur at relay switching time because of the energy stored in the inductive load. These flyback voltages can severely damage the relay contacts and greatly shorten the life of the relay.

It is best to limit these flyback voltages at your inductive load by installing, across your inductive load, a flyback diode for DC loads or a metal oxide varistor (MOV) for AC loads. Refer to the next section, [Guidelines for Selecting Contact Protection Circuits](#), for more information.

In addition, the FP-RLY-422 contains its own internal protection MOV to prevent excessively high voltage from being applied across the contacts. Each channel contains two MOVs: one between N.Closed and I.Com and one between N.Open and I.Com. However, National Instruments still recommends the use of a protection circuit across your inductive load.

# Guidelines for Selecting Contact Protection Circuits<sup>1</sup>

Proper selection is critical as the use of a contact-protection device can extend contact life. When mounting the protection device, always locate it near the immediate area of the load or contact. Typically you should mount a protective device within 18 in. of the load or contact.

Typically, contact-protection circuits are provided for an overview, but you should thoroughly examine the circuit you are planning to use.

## Diode and Zener Diode Circuit

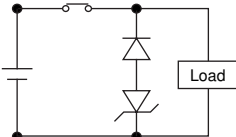
Diagram	Notes
	Use in DC applications only.
	Use when diode circuit causes too long release time.
	Use zener diode with zener voltage about equal to power supply voltage.

## Diode Circuit

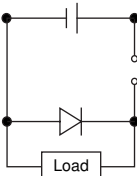
Diagram	Notes
	Use in DC applications only.
	Compared to RC type, circuit delays release time (2 to 5 times values stated in catalog).
	For larger voltages, use diode with reverse breakdown 10 times circuit voltage and forward load circuit.
	For smaller voltages, use reverse breakdown voltage of 2 to 3 times power supply voltage.

<sup>1</sup> This section has been reprinted with permission from American Zettler, Inc.

## CR Circuits

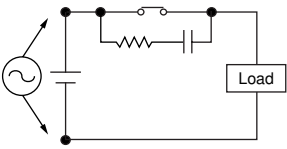
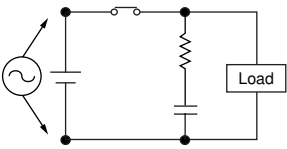
Diagram	Notes
	<p>Circuit A is suitable for AC or DC applications, but if used with AC voltage, impedance of the load should be smaller than the CR circuit's. Do not utilize for timer loads, as leakage current can cause faulty operations.</p>
	<p>Circuit B is suitable for AC or DC. If the load is a relay or solenoid, release times lengthen. Effective when connected to both contacts, power supply voltage across the load is 100 to 200 V.</p>

## Varistor Circuit

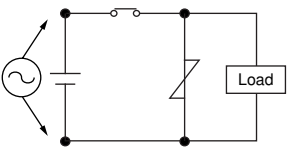
Diagram	Notes
	<p>Effective for AC and DC applications.</p> <p>Circuit slightly delays release time. Effective when connected to both contacts, power supply voltage across the load is 100 to 200 V.</p>

## In-Rush Current

The type of load and its in-rush current characteristics, together with switching frequency, can cause contact welding. For loads with in-rush current, measure the steady state current and in-rush current to determine the proper relay. Some typical types of loads and the in-rush current they create are summarized in the following table.

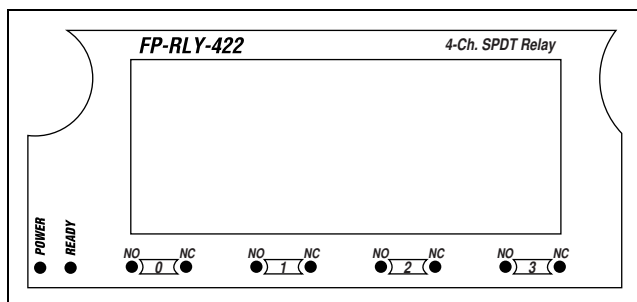

**Table 2.** Typical Load Types and In-Rush Currents

Type of Load	In-Rush Current
Resistive load	Steady-state current
Solenoid load	10 to 20 times the steady-state current
Motor load	5 to 10 times the steady-state current
Incandescent lamp load	10 to 15 times the steady-state current
Mercury lamp load	Approximately 3 times the steady-state current
Sodium vapor lamp load	1 to 3 times the steady-state current
Capacitive load	20 to 40 times the steady-state current
Transformer load	5 to 15 times the steady-state current

## Status Indicators

Figure 5 shows the module label and status indicators. You can remove the insertable label to see wiring diagrams for the relay channels.

**Figure 5.** Status Indicators and Module Label

After the module has been inserted into a terminal base (and power is applied), the green **POWER** indicator lights and the FP-RLY-422 informs the network module of its presence. When the network module recognizes the FP-RLY-422, the network module sends initial configuration information to the FP-RLY-422. After receiving this initial information, the green **READY** indicator lights and the FP-RLY-422 is in its normal operating mode. In addition to the green **POWER** and **READY** indicators, each channel has two, green, output state indicators labeled

NO and NC. The indicators show which terminal is connected to I.Com.

## Isolation and Safety Guidelines

---



**Caution** Read the following information before attempting to connect ANY circuits that may contain hazardous voltages to the FP-RLY-422.

This section describes the isolation of the FP-RLY-422 and its compliance with international safety standards. The outputs are isolated from the backplane of the terminal base with an isolation barrier designed and tested to protect against fault voltages of up to 3000 Vrms. In addition, the FP-RLY-422 provides *double insulation* (compliant to UL and IEC safety standards) for working common-mode voltages of 250 Vrms. Safety standards (such as those published by UL and IEC) require the use of double insulation between hazardous voltages and any human-accessible parts or circuits. You should *never* attempt to use any isolation product between human-accessible parts (such as DIN rails or monitoring stations) and circuits that may be at hazardous potentials under normal conditions, unless the product is specifically designed (as the FP-RLY-422 is) for such an application.

Even when a product like the FP-RLY-422 is used in applications with hazardous potentials, follow these guidelines to ensure a safe total system:

- The *safety* isolation of the FP-RLY-422 is from input to output, *not* between channels on the same module. If any of the channels on a module are wired at a hazardous potential, ensure that all other devices or circuits connected to that module are properly insulated from human contact.
- Do *not* share the external supply voltages (V and C on the terminal base) with other devices (including other FieldPoint devices) unless those devices are also isolated from human contact.

- As with any hazardous voltage wiring, ensure that all wiring and connections meet with applicable electrical codes or common sense practices. Mount terminal bases in an area, position, or cabinet that prevents accidental or unauthorized access to wiring with hazardous voltages.
- The isolation of the FP-RLY-422 is certified as double insulated for normal operating voltages of 250 Vrms. Do *not* use the FP-RLY-422 as the sole isolating barrier between human contact and working voltages of more than 250 Vrms.

## Specifications

---

The following specifications are typical for the range -40 to +70 °C, unless otherwise noted.

### Input Characteristics

Number of channels.....	4
Relay type .....	1 Form C (SPDT) Nonlatching
Maximum Switching Capacity (Resistive Load)	
AC .....	3 A at 250 VAC
DC .....	3 A at 35 VDC 2 A at 40 VDC 1 A at 55 VDC 0.4 A at 120 VDC
Minimum switching voltage .....	10 mA at 5 VDC
On resistance.....	100 mΩ
Off state leakage .....	0.3 μA at 250 VAC
Expected Life	
Mechanical .....	10 × 10 <sup>6</sup> operations min.
Electrical (at 30 cpm) .....	300,000 operations at 3 A, 35 VDC 100,000 operations at 3 A, 250 VAC
Maximum Switching Frequency	
Mechanical .....	20 operations per second
Electrical.....	1 operation per second at maximum load
Relays operate time.....	10 ms typical, 13 ms max.
Relays release time .....	5 ms typical, 7 ms max.

Relay bounce time .....	3 ms typical, 6 ms max.
Contact material .....	Silver cadmium oxide
Isolation (CH–GND and CH–CH)....	3,000 Vrms
Safety Isolation, Working Voltage (CH–GND only) .....	250 Vrms, designed per IEC 1010 as double insulated

## Physical

Indicators .....	Green <b>POWER</b> and <b>READY</b> indicators, 8 green output state indicators
Weight.....	182 g (6.4 oz.)

## Power Requirements

Power from network module .....	1000 mW
---------------------------------	---------

## Environment

Operating temperature .....	–40 to +70 °C
Storage temperature .....	–55 to +100 °C
Relative humidity.....	5% to 90% noncondensing

## CE Mark Compliance

This product meets applicable EU directive(s) as follows:

Safety isolation .....	EN 61010 (double insulation for 250 Vrms working isolation, installation category II)
------------------------	--

### EMC Directive

Immunity .....	EN 50082-1:1994
Emissions .....	EN 55011:1991 Group I Class A at 10 m

## Mechanical Dimensions

Figure 6 shows the mechanical dimensions of the FP-RLY-422 installed onto a terminal base. Dimensions are given in inches [millimeters].

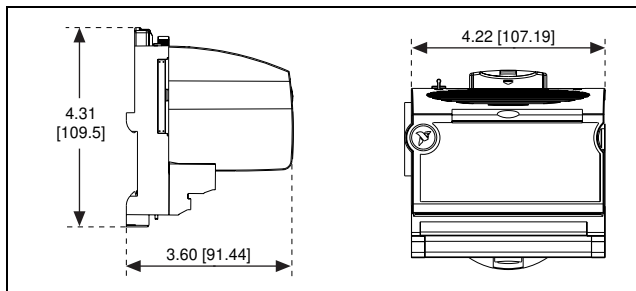

**Figure 6.** Mechanical Dimensions

