

## COMPREHENSIVE SERVICES

We offer competitive repair and calibration services, as well as easily accessible documentation and free downloadable resources.

## SELL YOUR SURPLUS

We buy new, used, decommissioned, and surplus parts from every NI series. We work out the best solution to suit your individual needs.

 Sell For Cash    Get Credit    Receive a Trade-In Deal

## OBSOLETE NI HARDWARE IN STOCK & READY TO SHIP

We stock **New**, **New Surplus**, **Refurbished**, and **Reconditioned** NI Hardware.



*Bridging the gap between the manufacturer and your legacy test system.*

 1-800-915-6216

 [www.apexwaves.com](http://www.apexwaves.com)

 [sales@apexwaves.com](mailto:sales@apexwaves.com)

*All trademarks, brands, and brand names are the property of their respective owners.*

**Request a Quote**

 **CLICK HERE**

**FP-RTD-124**

# FP-RTD-122 and cFP-RTD-122

## Eight-Channel Three-Wire RTD and Resistance Input Modules

These operating instructions describe how to install and use the National Instruments FP-RTD-122 and cFP-RTD-122 three-wire RTD and resistance input modules (referred to inclusively as the [c]FP-RTD-122). For details on configuring and accessing the [c]FP-RTD-122 over a network, refer to the user manual for the FieldPoint network module you are using.

## Features

---

The [c]FP-RTD-122 is a FieldPoint RTD and resistance input module with the following features:

- Inputs for 100 and 1,000  $\Omega$  platinum RTDs (resistance temperature detectors)
- Built-in linearization for six TCR (temperature coefficient of resistance, or alpha) values of RTDs
- Direct resistance measurements in 400 and 4,000  $\Omega$  ranges
- True three-wire compensation
- 16-bit resolution
- Filtering against 50 and 60 Hz noise
- Hot swappable
- 2,300  $V_{\text{rms}}$  transient overvoltage protection
- $-40$  to  $70$   $^{\circ}\text{C}$  operation

---

FieldPoint™, National Instruments™, NI™, and ni.com™ are trademarks of National Instruments Corporation. Product and company names mentioned herein are trademarks or trade names of their respective companies. For patents covering National Instruments products, refer to the appropriate location: **Help»Patents** in your software, the `patents.txt` file on your CD, or `ni.com/patents`.

# Installing the FP-RTD-122

The FP-RTD-122 mounts on a FieldPoint terminal base (FP-TB-*x*), which provides operating power to the module. Installing the FP-RTD-122 onto a powered terminal base does not disrupt the operation of the bank.

To install the FP-RTD-122, refer to Figure 1 and complete the following steps:

1. Slide the terminal base key to either position X, used for any module, or position 1, used for the FP-RTD-122 module.
2. Align the FP-RTD-122 alignment slots with the guide rails on the terminal base.
3. Press firmly to seat the FP-RTD-122 on the terminal base. When the module is firmly seated, the terminal base latch locks it into place.

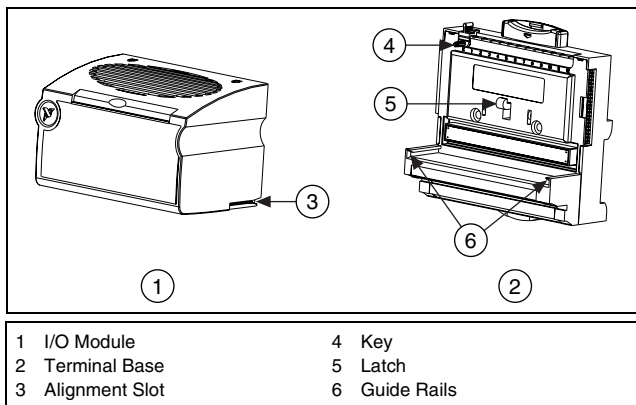

Figure 1. Installing the FP-RTD-122

# Installing the cFP-RTD-122

The cFP-RTD-122 mounts on a Compact FieldPoint backplane (cFP-BP-*x*), which provides operating power to the module. Installing the cFP-RTD-122 onto a powered backplane does not disrupt the operation of the bank.

To install the cFP-RTD-122, refer to Figure 2 and complete the following steps:

1. Align the captive screws on the cFP-RTD-122 with the holes on the backplane. The alignment keys on the cFP-RTD-122 prevent backward insertion.
2. Press firmly to seat the cFP-RTD-122 on the backplane.
3. Using a number 2 Phillips screwdriver with a shank of at least 64 mm (2.5 in.) length, tighten the captive screws to 1.1 N · m (10 lb · in.) of torque. The nylon coating on the screws prevents them from loosening.

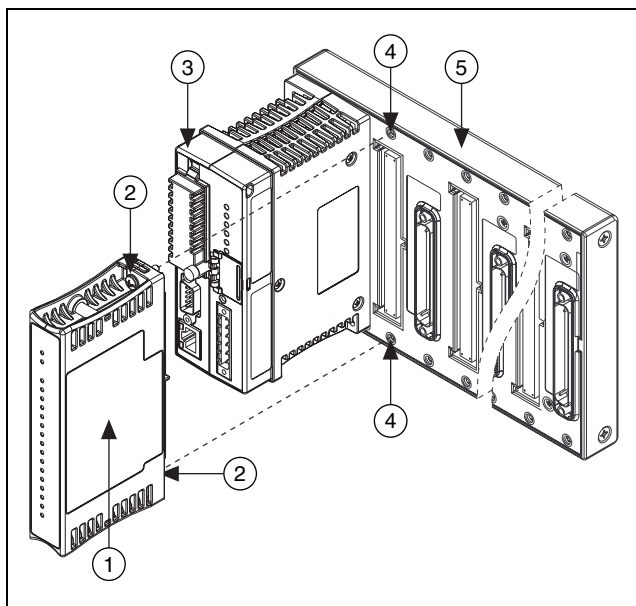

- |                         |                 |
|-------------------------|-----------------|
| 1 cFP-RTD-122           | 4 Screw Holes   |
| 2 Captive Screws        | 5 cFP Backplane |
| 3 cFP Controller Module |                 |

**Figure 2.** Installing the cFP-RTD-122

# Wiring the [c]FP-RTD-122

---

The FP-TB-*x* terminal bases have connections for each of the eight input channels on the FP-RTD-122. The cFP-CB-*x* connector blocks provide the same connections for the cFP-RTD-122.

Table 1 lists the terminal assignments for the signals associated with each channel. The terminal assignments are the same for the FP-TB-*x* terminal bases and the cFP-CB-*x* connector blocks.

**Table 1.** Terminal Assignments

Channel	Terminal Numbers		
	EX+	SENSE	COM
0	1	2	18
1	3	4	20
2	5	6	22
3	7	8	24
4	9	10	26
5	11	12	28
6	13	14	30
7	15	16	32

If you are using shielded wiring, you can reduce input signal noise by connecting one end of the shield to the COM terminal. Do not connect the shield to any of the wires at the signal end.

## Taking RTD Measurements with the [c]FP-RTD-122

---

The [c]FP-RTD-122 has eight input channels. All eight channels share a common ground reference that is isolated from other modules in the FieldPoint system. Each channel pulses a 0.25 mA excitation current out of the EX+ terminal. The excitation current returns through the COM terminal. The SENSE terminal measures resistance and compensates for lead resistance errors. Each channel is filtered, then sampled by a 16-bit analog-to-digital converter.

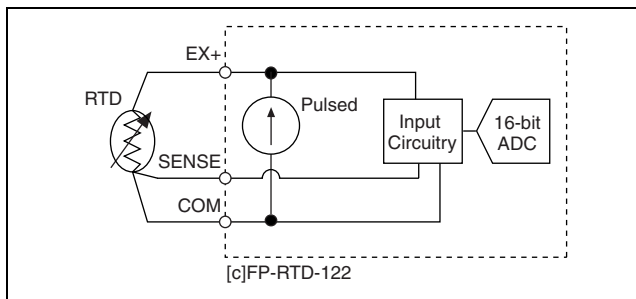

**Figure 3.** [c]FP-RTD-122 Input Circuitry

## Taking Measurements from Three-Wire RTDs

Three-wire RTDs often have a wire of one color (usually white, sometimes red) for positive excitation, and two wires of another color (usually red, sometimes black). Connect the positive excitation wire to the EX+ terminal of the module, and connect the other two wires to the SENSE and COM terminals.

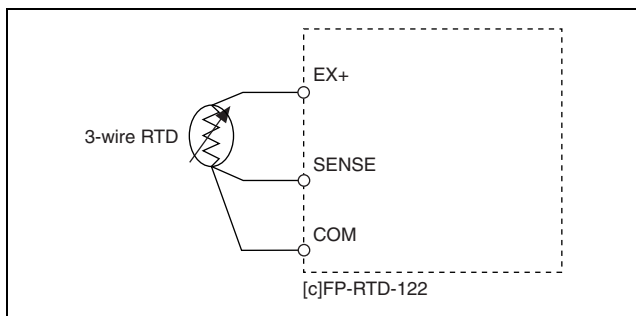

**Figure 4.** Three-Wire RTD Connections on One Channel

## Taking Measurements from Four-Wire RTDs

For the best accuracy, use the NI [c]FP-RTD-124 for input from four-wire RTDs. Otherwise, leave any one of the RTD wires unconnected and connect the remaining three as you would for a three-wire RTD. Refer to Figure 5.

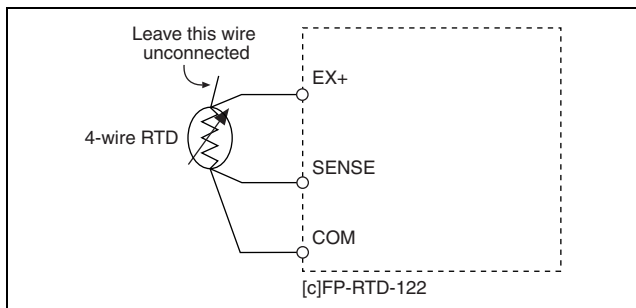

**Figure 5.** Four-Wire RTD Connections on One Channel

## Taking Measurements from Two-Wire RTDs

Connect either wire of a two-wire RTD to the EX+ terminal and the other wire to the COM terminal, and connect a short jumper wire between the COM and SENSE terminals.

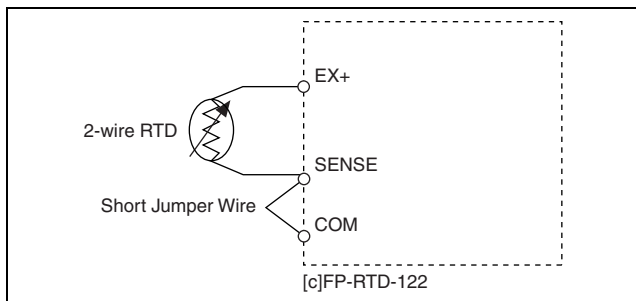

**Figure 6.** Two-Wire RTD Connections on One Channel

## Measuring Resistance Directly

You can use the [c]FP-RTD-122 to measure resistance in ohms. In this way, you can take measurements from RTDs of types that the [c]FP-RTD-122 does not directly support (such as 120  $\Omega$  nickel RTDs) and from resistive devices other than RTDs. You can choose one of two resistance ranges: 0–400 and 0–4,000  $\Omega$ . Resistance values outside the range you select, including open circuits, result in an **Out of range** error for the affected channels. The [c]FP-RTD-122 ignores any configuration of RTD type for channels with resistance ranges selected.

# Converting Resistance Measurements to Temperature Measurements

---

The [c]FP-RTD-122 has built-in linearization algorithms for platinum RTDs of either 100 or 1,000  $\Omega$  nominal resistance, and for six TCR (or alpha,  $\alpha$ ) values. The TCR is the average temperature coefficient of resistance of an RTD from 0 to 100  $^{\circ}\text{C}$ . This document specifies TCR in units of  $\text{m}\Omega/\Omega/^{\circ}\text{C}$ .

The [c]FP-RTD-122 linearizes resistance values and returns readings in units of temperature. The available ranges are 73 to 1,123 K,  $-200$  to  $850$   $^{\circ}\text{C}$ , and  $-328$  to  $1,562$   $^{\circ}\text{F}$ . You can configure each channel independently, so you can connect different types of RTDs to each channel.



**Note** You must configure each channel of the [c]FP-RTD-122 for the RTD type connected to it. The module does not automatically recognize RTD types.

## RTD Types

RTD types are specified by material composition, nominal resistance at 0  $^{\circ}\text{C}$ , and TCR. The [c]FP-RTD-122 can directly measure the temperature of platinum RTDs of either 100 or 1,000  $\Omega$  nominal resistance. These RTDs are commonly referred to as PT100 or PT1000 RTDs, respectively.

Different types of platinum RTDs have different TCRs. The [c]FP-RTD-122 supports the following TCRs: 3.750, 3.851, 3.911, 3.916, 3.920, and 3.928  $\text{m}\Omega/\Omega/^{\circ}\text{C}$ . The most common TCR for RTDs is 3.851  $\text{m}\Omega/\Omega/^{\circ}\text{C}$ . It is defined in international standards such as IEC-751, DIN 43760, BS 1904, and ASTM E1137.

The TCR of 3.928  $\text{m}\Omega/\Omega/^{\circ}\text{C}$  is used in the reference function for platinum thermometers in the International Temperature Scale of 1990 (ITS-90) for high-accuracy metrology applications.

Unfortunately, not all TCR values are as well defined by standards organizations, and the behavior of RTDs with the same TCR value may vary from vendor to vendor. The variations are usually small, and the built-in linearization algorithms of the [c]FP-RTD-122 are appropriate for nearly all applications.



The [c]FP-RTD-122 uses a linearization curve known as the Callendar-Van Dusen equation to measure the temperature of RTDs. The equation is as follows:

Temperatures below 0 °C:

$$R_T = R_0[1 + A \times T + B \times T^2 + C \times T^3 \times (T - 100 \text{ °C})]$$

Temperatures above 0 °C:

$$R_T = R_0[1 + A \times T + B \times T^2]$$

$T$  = temperature in °C

$R_T$  = RTD resistance at temperature  $T$

$R_0$  = RTD nominal resistance at 0 °C

A, B, C are coefficients given in Table 2.

Table 2 lists the coefficients used in this equation for each of the TCR values that the [c]FP-RTD-122 supports. If you have a nonstandard RTD that does not match one of these linearization curves, measure the resistance with the [c]FP-RTD-122 and convert the resistance to temperature in the manner suggested by the RTD vendor.

**Table 2.** Callendar-Van Dusen Coefficients Used by the [c]FP-RTD-122

TCR mΩ/Ω/°C	A (°C) <sup>-1</sup>	B (°C) <sup>-2</sup>	C (°C) <sup>-4</sup>
3.750 <sup>a</sup>	$3.81 \times 10^{-3}$	$-6.02 \times 10^{-7}$	$-6.0 \times 10^{-12}$
3.851 <sup>b</sup>	$3.9083 \times 10^{-3}$	$-5.775 \times 10^{-7}$	$-4.183 \times 10^{-12}$
3.911 <sup>c</sup>	$3.9692 \times 10^{-3}$	$-5.8495 \times 10^{-7}$	$-4.233 \times 10^{-12}$
3.916 <sup>d</sup>	$3.9739 \times 10^{-3}$	$-5.870 \times 10^{-7}$	$-4.4 \times 10^{-12}$
3.920 <sup>e</sup>	$3.9787 \times 10^{-3}$	$-5.8686 \times 10^{-7}$	$-4.167 \times 10^{-12}$
3.928 <sup>f</sup>	$3.9888 \times 10^{-3}$	$-5.915 \times 10^{-7}$	$-3.85 \times 10^{-12}$

## Three-Wire Compensation of Lead Resistance Errors

The [c]FP-RTD-122 uses a three-wire compensation technique to compensate for the lead resistances. The SENSE lead measures the resistance of the return COM lead. If the EX+ lead has the same resistance as the COM lead, the [c]FP-RTD-122 corrects for the

effects of the leads. The only residual errors are those caused by mismatching the EX+ and COM leads. Most RTDs have lead resistances within 5% of each other, so the compensation of the [c]FP-RTD-122 corrects for 95% or more of the errors introduced by lead resistances. This is a more accurate method than the typical bridge completion methods described in many reference books. The bridge methods not only have the same sensitivity to lead resistance mismatch, but also are effective only for temperatures very near those at which the bridge is balanced (usually 0 °C).

The temperature measurement accuracy specifications for the [c]FP-RTD-122 at the end of these instructions include the effects of a typical application using 10 m of 22 gauge copper wire (approximately 0.5  $\Omega$  per lead), with 5% mismatch in the lead resistances. If you are using leads with greater resistances, the additional errors are approximately 3 °C per  $\Omega$  of mismatch in the lead resistances for 100  $\Omega$  RTDs, and 0.3 °C per  $\Omega$  of mismatch in the lead resistance for 1,000  $\Omega$  RTDs. For example, for 2  $\Omega$  leads matched to 5% of each other, the lead resistance mismatch is  $5\% \times 2 \Omega = 0.1 \Omega$ , which would cause 0.3 °C of error in measurements of a 100  $\Omega$  RTD.

If you are using the [c]FP-RTD-122 with two-wire RTDs, the errors due to lead resistances are much greater because three-wire compensation is not used. With two-wire RTDs, the additional errors are approximately 3 °C per  $\Omega$  of the sum of the lead resistances for 100  $\Omega$  RTDs, and 0.3 °C per  $\Omega$  of the sum of lead resistances for 1,000  $\Omega$  RTDs. For example, a 1,000  $\Omega$  two-wire RTD with 2  $\Omega$  leads has a total lead resistance of 4  $\Omega$  (2  $\Omega$  per lead), which causes 1.2 °C of error.

## Status Indicators

---

The [c]FP-RTD-122 has two green status LEDs, **POWER** and **READY**. After you insert the [c]FP-RTD-122 into a terminal base or backplane and apply power to the connected network module, the green **POWER** indicator lights and the [c]FP-RTD-122 informs the network module of its presence. When the network module recognizes the [c]FP-RTD-122, it sends initial configuration information to the [c]FP-RTD-122. After the [c]FP-AI-111 receives this initial information, the green **READY** indicator lights and the module is in normal operating mode.

# Upgrading the FieldPoint Firmware

---

You may need to upgrade the FieldPoint firmware when you add new I/O modules to the FieldPoint system. For information on determining which firmware you need and how to upgrade your firmware, go to [ni.com/info](http://ni.com/info) and enter `fpmatrix`.

## Isolation and Safety Guidelines

---



**Caution** Read the following information before attempting to connect the [c]FP-RTD-122 to any circuits that may contain hazardous voltages.

This section describes the isolation of the [c]FP-RTD-122 and its compliance with international safety standards. The field wiring connections are isolated from the backplane and the inter-module communication bus. The isolation is provided by the module, which has optical and galvanic isolation barriers designed and tested to protect against transient fault voltages of up to 2,300 V<sub>rms</sub>.

Follow these guidelines to ensure a safe total system:

- The [c]FP-RTD-122 has a safety isolation barrier between the I/O channels and the inter-module communication bus. There is no isolation between channels unless otherwise noted. If any of the channels on a module are wired at a hazardous potential, make sure that all other devices or circuits connected to that module are properly insulated from human contact.
- Do *not* share the external supply voltages (the V and C terminals) with other devices (including other FieldPoint devices), unless those devices are isolated from human contact.
- For Compact FieldPoint, you *must* connect the protective earth (PE) ground terminal on the cFP-BP-*x* backplane to the system safety ground. The backplane PE ground terminal has the following symbol stamped beside it: . Connect the backplane PE ground terminal to the system safety ground using 14 AWG (1.6 mm) wire with a ring lug. Use the 5/16 in. panhead screw shipped with the backplane to secure the ring lug to the backplane PE ground terminal.
- As with any hazardous voltage wiring, make sure that all wiring and connections meet applicable electrical codes and commonsense practices. Mount terminal bases and backplanes in an area, position, or cabinet that prevents accidental or unauthorized access to wiring that carries hazardous voltages.

- Operate the [c]FP-RTD-122 only at or below Pollution Degree 2. Pollution Degree 2 means that only nonconductive pollution occurs in most cases. Occasionally, however, a temporary conductivity caused by condensation must be expected.
- Refer to the FieldPoint product label for regulatory certification under hazardous location standards. If the FieldPoint product is not certified for operation in hazardous locations, do not operate it in an explosive atmosphere or where there may be flammable gases or fumes.

## Specifications

These specifications are typical for the range  $-40$  to  $70^{\circ}\text{C}$  unless otherwise noted. Gain error is calculated as a percentage of input signal value.

### Input Characteristics

Number of channels.....	8
ADC resolution.....	16 bits
Type of ADC.....	Delta-sigma
Input signal ranges (software selectable by channel)	
Temperature.....	73 to 1123 K -200 to 850 $^{\circ}\text{C}$ -328 to 1562 $^{\circ}\text{F}$
Resistance.....	0 to 400 $\Omega$ or 0 to 4,000 $\Omega$
Temperature accuracy (includes 5% matched, 0.5 $\Omega$ lead wires—10 m of 22 AWG copper)	

Measured Value	Error			
	15 to 35 $^{\circ}\text{C}$		-40 to 70 $^{\circ}\text{C}$	
	Typical	Maximum	Typical	Maximum
-200 to 150 $^{\circ}\text{C}$	0.15	0.30	0.40	1.6
150 to 850 $^{\circ}\text{C}$	0.25	0.50	0.90	3.0

Resolution.....0.016  $^{\circ}\text{C}$

Resistance accuracy

    Offset error, 400  $\Omega$  range

        15 to 35  $^{\circ}\text{C}$ .....0.03  $\Omega$  typ, 0.08  $\Omega$  max

        -40 to 70  $^{\circ}\text{C}$ .....0.08  $\Omega$  typ, 0.4  $\Omega$  max

#### Offset error, 4,000 $\Omega$ range

15 to 35 °C ..... 0.2  $\Omega$  typ, 0.7  $\Omega$  max

-40 to 70 °C ..... 0.8  $\Omega$  typ, 4.0  $\Omega$  max

#### Gain error

15 to 35 °C ..... 0.01% typ, 0.02% max

-40 to 70 °C ..... 0.07% typ, 0.1% max

#### Resolution

400  $\Omega$  range ..... 0.0061  $\Omega$

4,000  $\Omega$  range ..... 0.061  $\Omega$

Excitation current ..... 135 ms pulses of 0.25 mA  
every 1,080 ms

Input noise .....  $\pm 1$  bit peak-to-peak

Input bandwidth ..... 3 Hz

Update rate ..... Each channel is updated  
every 1.08 s

## Physical Characteristics

Indicators ..... Green **POWER** and  
**READY** indicators

#### Weight

FP-RTD-122 ..... 140 g (4.8 oz)

cFP-RTD-122 ..... 110 g (3.7 oz)

## Power Requirements

Power from network module ..... 350 mW

## Isolation Voltage

Channel-to-channel isolation ..... No isolation between  
channels

Transient overvoltage ..... 2,300 V<sub>rms</sub>

## Environmental

FieldPoint modules are intended for indoor use only. For outdoor use, FieldPoint modules must be mounted inside a sealed enclosure.

Operating temperature ..... -40 to 70 °C

Storage temperature ..... -55 to 85 °C

Humidity ..... 10 to 90% RH,  
noncondensing

Maximum altitude.....	2,000 m; at higher altitudes the isolation voltage ratings must be lowered
Pollution Degree .....	2

## Shock and Vibration

These specifications apply only to the cFP-RTD-122.

NI recommends Compact FieldPoint if your application is subject to shock and vibration.

Operating vibration, random (IEC 60068-2-64).....	10–500 Hz, 5 g <sub>rms</sub>
Operating vibration, sinusoidal (IEC 60068-2-6).....	10–500 Hz, 5 g
Operating shock (IEC 60068-2-27).....	50 g, 3 ms half sine, 18 shocks at 6 orientations; 30 g, 11 ms half sine, 18 shocks at 6 orientations

## Safety

This product is designed to meet the requirements of the following standards of safety for electrical equipment for measurement, control, and laboratory use:

- IEC 61010-1, EN 61010-1
- UL 3121-1, UL 61010C-1
- CAN/CSA C22.2 No. 1010.1

For UL, hazardous location, and other safety certifications, refer to the product label or to [ni.com](http://ni.com).

## Electromagnetic Compatibility

CE, C-Tick, and FCC Part 15 (Class A) Compliant

Emissions.....	EN 55011 Class A at 10 m FCC Part 15A above 1 GHz
Immunity.....	EN 61326:1997 + A2:2001, Table 1



**Note** For EMC compliance, operate this device with shielded cabling.

## CE Compliance

This product meets the essential requirements of applicable European Directives, as amended for CE Marking, as follows:

Low-Voltage Directive (safety)..... 73/23/EEC

Electromagnetic Compatibility

Directive (EMC) ..... 89/336/EEC



**Note** Refer to the Declaration of Conformity (DoC) for this product for any additional regulatory compliance information. To obtain the DoC for this product, click **Declarations of Conformity Information** at [ni.com/hardref.nsf/](http://ni.com/hardref.nsf/).

## Mechanical Dimensions

Figure 7 shows the mechanical dimensions of the FP-RTD-122 installed on a terminal base. If you are using the cFP-RTD-122, refer to the Compact FieldPoint controller user manual for the dimensions and cabling clearance requirements of the Compact FieldPoint system.

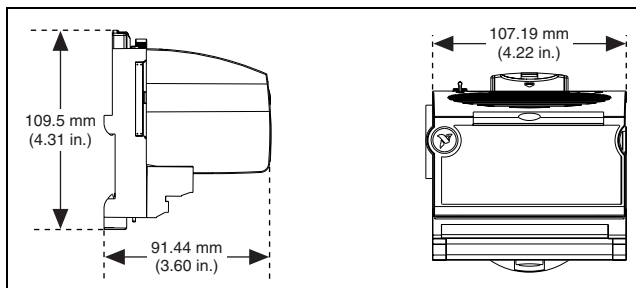

**Figure 7.** FP-RTD-122 Mechanical Dimensions

## Where to Go for Support

For more information about setting up the FieldPoint system, refer to these National Instruments documents:

- FieldPoint network module user manual
- Other FieldPoint I/O module operating instructions
- FieldPoint terminal base and connector block operating instructions

Go to [ni.com/support](http://ni.com/support) for the most current manuals, examples, and troubleshooting information.

For telephone support in the United States, create your service request at [ni.com/ask](http://ni.com/ask) and follow the calling instructions or dial 512 795 8248. For telephone support outside the United States, contact your local branch office:

Australia 61 2 9672 8846, Austria 43 0 662 45 79 90 0,  
Belgium 32 0 2 757 00 20, Brazil 55 11 3262 3599,  
Canada (Calgary) 403 274 9391,  
Canada (Montreal) 514 288 5722,  
Canada (Ottawa) 613 233 5949, Canada (Québec) 514 694 8521,  
Canada (Toronto) 905 785 0085,  
Canada (Vancouver) 514 685 7530, China 86 21 6555 7838,  
Czech Republic 420 2 2423 5774, Denmark 45 45 76 26 00,  
Finland 385 0 9 725 725 11, France 33 0 1 48 14 24 24,  
Germany 49 0 89 741 31 30, Greece 30 2 10 42 96 427,  
Hong Kong 2645 3186, India 91 80 51190000,  
Israel 972 0 3 6393737, Italy 39 02 413091,  
Japan 81 3 5472 2970, Korea 82 02 3451 3400,  
Malaysia 603 9059 6711, Mexico 001 800 010 0793,  
Netherlands 31 0 348 433 466, New Zealand 64 09 914 0488,  
Norway 47 0 32 27 73 00, Poland 48 0 22 3390 150,  
Portugal 351 210 311 210, Russia 7 095 238 7139,  
Singapore 65 6 226 5886, Slovenia 386 3 425 4200, South  
Africa 27 0 11 805 8197, Spain 34 91 640 0085,  
Sweden 46 0 8 587 895 00, Switzerland 41 56 200 51 51,  
Taiwan 886 2 2528 7227, United Kingdom 44 0 1635 523545