

## COMPREHENSIVE SERVICES

We offer competitive repair and calibration services, as well as easily accessible documentation and free downloadable resources.

## SELL YOUR SURPLUS

We buy new, used, decommissioned, and surplus parts from every NI series. We work out the best solution to suit your individual needs.

 Sell For Cash    Get Credit    Receive a Trade-In Deal

## OBSOLETE NI HARDWARE IN STOCK & READY TO SHIP

We stock **New**, **New Surplus**, **Refurbished**, and **Reconditioned** NI Hardware.



*Bridging the gap between the manufacturer and your legacy test system.*

 1-800-915-6216

 [www.apexwaves.com](http://www.apexwaves.com)

 [sales@apexwaves.com](mailto:sales@apexwaves.com)

*All trademarks, brands, and brand names are the property of their respective owners.*

**Request a Quote**

 **CLICK HERE**

**GPIB-120A**



# Installation Guide for Single Rack-Mount Kit for GPIB-100A, GPIB-110, and GPIB-120A

Part Number 320697-01

This guide describes how to install the rack-mount hardware for a single GPIB-100A or GPIB-110 bus extender, or GPIB-120A bus expander.

## What Your Kit Should Contain

Item	Component	Part Number	Quantity
A	Handle Mounting Trim Strips	180246-01	2
B	Rack-Mount Bracket, Long	179058-01 (or -51)	1
C	Rack-Mount Bracket, Short	179059-01 (or -51)	1
D	6-32 by 5/16 in. Screws	741207-01	4
E	#6 Tooth Lock Washers	740402-01	4

In addition to the rack-mount kit contents, you also need the following items:

- 0-point Phillips head screwdriver
- Small flat-head screwdriver
- Alcohol-based solvent
- Cloth for wiping off glue residue

## Installation Procedure

Refer to the illustration on the reverse of this form as you read the following installation instructions.

1. Remove the four 4-40 flat-head screws from the corners of the case.
2. Remove the top half of the case.
3. Using a small flat-head screwdriver, pry the upper edge of trim strips loose and remove the strips from both sides of the case.
4. Remove any excess glue that may be left on the case with an alcohol-based solvent and wipe clean with a cloth.
5. Replace the top half of the case and replace the four flat-head screws.
6. Slide a handle mounting trim strip (Item A) into the outside slot on each side of the case with the part number toward the case.
7. Attach rack-mount brackets (Items B and C) to the handle mounting trim strips (Item A) using four 6-32 by 5/16 in. screws (Item D) and the four lock washers (Item E).
  - a. For a flush bezel mount, use the hole pattern closest to the rear of the rack-mount brackets.
  - b. To mount the unit with 0.5 in. bezel protruding in front of the rack-mount brackets, use the hole pattern closest to the front of the brackets.

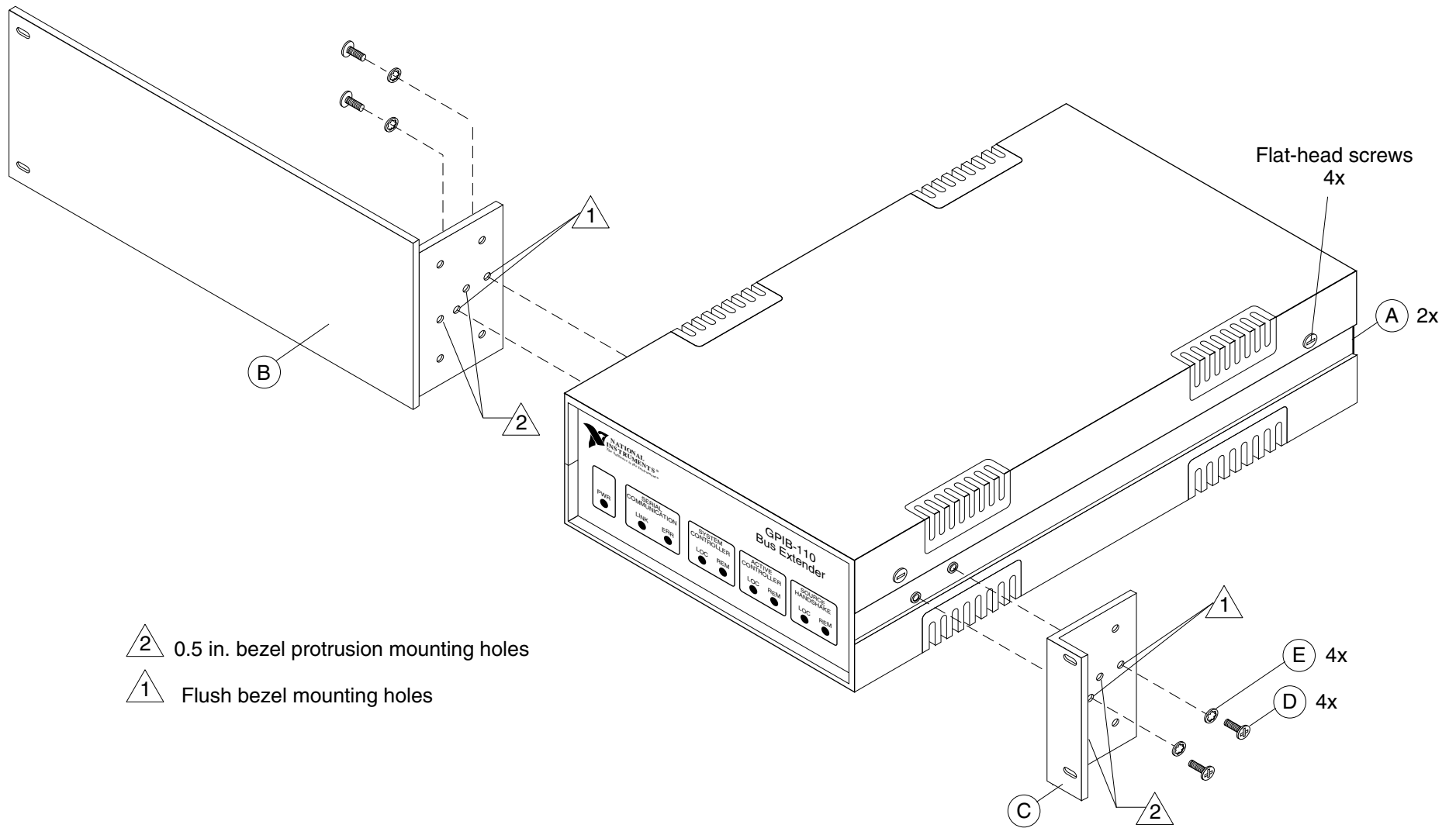

- 2 0.5 in. bezel protrusion mounting holes
- 1 Flush bezel mounting holes

(GPIB-110 shown for illustration purposes only)