

COMPREHENSIVE SERVICES

We offer competitive repair and calibration services, as well as easily accessible documentation and free downloadable resources.

SELL YOUR SURPLUS

We buy new, used, decommissioned, and surplus parts from every NI series. We work out the best solution to suit your individual needs.

 Sell For Cash  Get Credit  Receive a Trade-In Deal

OBSOLETE NI HARDWARE IN STOCK & READY TO SHIP

We stock **New**, **New Surplus**, **Refurbished**, and **Reconditioned** NI Hardware.



Bridging the gap between the manufacturer and your legacy test system.

 1-800-915-6216

 www.apexwaves.com

 sales@apexwaves.com

All trademarks, brands, and brand names are the property of their respective owners.

Request a Quote

 **CLICK HERE**

NB-DIO-32F

DAQ

SCXI™-1200 User Manual

12-Bit Data Acquisition and Control Module

December 1996 Edition
Part Number 371186A-01



Internet Support

support@natinst.com

E-mail: info@natinst.com

FTP Site: ftp.natinst.com

Web Address: <http://www.natinst.com>



Bulletin Board Support

BBS United States: (512) 794-5422 or (800) 327-3077

BBS United Kingdom: 01635 551422

BBS France: 1 48 65 15 59



FaxBack Support

(512) 418-1111

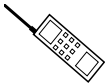

Telephone Support (U.S.)

Tel: (512) 795-8248

Fax: (512) 794-5678

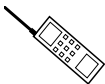

International Offices

Australia 03 9879 5166, Austria 0662 45 79 90 0, Belgium 02 757 00 20,

Canada (Ontario) 905 785 0085, Canada (Québec) 514 694 8521, Denmark 45 76 26 00,

Finland 09 527 2321, France 01 48 14 24 24, Germany 089 741 31 30, Hong Kong 2645 3186,

Israel 03 5734815, Italy 02 413091, Japan 03 5472 2970, Korea 02 596 7456, Mexico 5 520 2635,

Netherlands 0348 433466, Norway 32 84 84 00, Singapore 2265886, Spain 91 640 0085,

Sweden 08 730 49 70, Switzerland 056 200 51 51, Taiwan 02 377 1200, U.K. 01635 523545

National Instruments Corporate Headquarters

6504 Bridge Point Parkway Austin, TX 78730-5039 Tel: (512) 794-0100

Important Information

Warranty

The SCXI-1200 is warranted against defects in materials and workmanship for a period of one year from the date of shipment, as evidenced by receipts or other documentation. National Instruments will, at its option, repair or replace equipment that proves to be defective during the warranty period. This warranty includes parts and labor.

The media on which you receive National Instruments software are warranted not to fail to execute programming instructions, due to defects in materials and workmanship, for a period of 90 days from date of shipment, as evidenced by receipts or other documentation. National Instruments will, at its option, repair or replace software media that do not execute programming instructions if National Instruments receives notice of such defects during the warranty period. National Instruments does not warrant that the operation of the software shall be uninterrupted or error free.

A Return Material Authorization (RMA) number must be obtained from the factory and clearly marked on the outside of the package before any equipment will be accepted for warranty work. National Instruments will pay the shipping costs of returning to the owner parts which are covered by warranty.

National Instruments believes that the information in this manual is accurate. The document has been carefully reviewed for technical accuracy. In the event that technical or typographical errors exist, National Instruments reserves the right to make changes to subsequent editions of this document without prior notice to holders of this edition. The reader should consult National Instruments if errors are suspected. In no event shall National Instruments be liable for any damages arising out of or related to this document or the information contained in it.

EXCEPT AS SPECIFIED HEREIN, NATIONAL INSTRUMENTS MAKES NO WARRANTIES, EXPRESS OR IMPLIED, AND SPECIFICALLY DISCLAIMS ANY WARRANTY OF MERCHANTABILITY OR FITNESS FOR A PARTICULAR PURPOSE. CUSTOMER'S RIGHT TO RECOVER DAMAGES CAUSED BY FAULT OR NEGLIGENCE ON THE PART OF NATIONAL INSTRUMENTS SHALL BE LIMITED TO THE AMOUNT THERETOFOR PAID BY THE CUSTOMER. NATIONAL INSTRUMENTS WILL NOT BE LIABLE FOR DAMAGES RESULTING FROM LOSS OF DATA, PROFITS, USE OF PRODUCTS, OR INCIDENTAL OR CONSEQUENTIAL DAMAGES, EVEN IF ADVISED OF THE POSSIBILITY THEREOF. This limitation of the liability of National Instruments will apply regardless of the form of action, whether in contract or tort, including negligence. Any action against National Instruments must be brought within one year after the cause of action accrues. National Instruments shall not be liable for any delay in performance due to causes beyond its reasonable control. The warranty provided herein does not cover damages, defects, malfunctions, or service failures caused by owner's failure to follow the National Instruments installation, operation, or maintenance instructions; owner's modification of the product; owner's abuse, misuse, or negligent acts; and power failure or surges, fire, flood, accident, actions of third parties, or other events outside reasonable control.

Copyright

Under the copyright laws, this publication may not be reproduced or transmitted in any form, electronic or mechanical, including photocopying, recording, storing in an information retrieval system, or translating, in whole or in part, without the prior written consent of National Instruments Corporation.

Trademarks

LabVIEW®, NI-DAQ®, RTSI®, CVI™, and SCXI™ are trademarks of National Instruments Corporation. Product and company names listed are trademarks or trade names of their respective companies.

WARNING REGARDING MEDICAL AND CLINICAL USE OF NATIONAL INSTRUMENTS PRODUCTS

National Instruments products are not designed with components and testing intended to ensure a level of reliability suitable for use in treatment and diagnosis of humans. Applications of National Instruments products involving medical or clinical treatment can create a potential for accidental injury caused by product failure, or by errors on the part of the user or application designer. Any use or application of National Instruments products for or involving medical or clinical treatment must be performed by properly trained and qualified medical personnel, and all traditional medical safeguards, equipment, and procedures that are appropriate in the particular situation to prevent serious injury or death should always continue to be used when National Instruments products are being used. National Instruments products are NOT intended to be a substitute for any form of established process, procedure, or equipment used to monitor or safeguard human health and safety in medical or clinical treatment.



*Table
of
Contents*

About This Manual

| | |
|--|-----|
| Organization of This Manual | ix |
| Conventions Used in This Manual | x |
| National Instruments Documentation | xi |
| Related Documentation | xii |
| Customer Communication | xii |

Chapter 1

Introduction

| | |
|---|-----|
| About the SCXI-1200 | 1-1 |
| What You Need to Get Started | 1-2 |
| Software Programming Choices | 1-2 |
| LabVIEW and LabWindows/CVI Application Software | 1-3 |
| NI-DAQ Driver Software | 1-3 |
| Register-Level Programming | 1-4 |
| Optional Equipment | 1-5 |
| Custom Cables | 1-5 |
| Unpacking | 1-6 |

Chapter 2

Installation and Configuration

| | |
|---|-----|
| Hardware Installation | 2-1 |
| Module Configuration | 2-2 |
| Direct Parallel Port Connection to PC | 2-3 |
| Analog I/O Configuration | 2-5 |
| Analog Output Configuration | 2-6 |
| Analog Input Configuration | 2-6 |
| Input Mode | 2-6 |
| RSE Input (Eight Channels, Factory Setting) | 2-8 |
| NRSE Input (Eight Channels) | 2-8 |
| DIFF Input (Four Channels) | 2-8 |
| Analog Input Polarity and Range Configuration | 2-9 |
| SCXI Configuration | 2-9 |

Chapter 3

Signal Connections

| | |
|---|------|
| Front Connector..... | 3-2 |
| Front Connector Signal Connection Descriptions | 3-2 |
| Analog Input Signal Connections | 3-4 |
| Types of Signal Sources..... | 3-6 |
| Floating Signal Sources | 3-6 |
| Ground-Referenced Signal Sources..... | 3-6 |
| Input Configurations | 3-7 |
| Differential Connection Considerations (DIFF Configuration) | 3-7 |
| Differential Connections for Grounded Signal Sources | 3-8 |
| Differential Connections for Floating Signal Sources..... | 3-9 |
| Single-Ended Connection Considerations | 3-10 |
| Single-Ended Connections for Floating Signal Sources (RSE Configuration) | 3-11 |
| Single-Ended Connections for Grounded Signal Sources (NRSE Configuration) | 3-11 |
| Common-Mode Signal Rejection Considerations | 3-13 |
| Analog Output Signal Connections..... | 3-13 |
| Digital I/O Signal Connections..... | 3-14 |
| Port C Pin Connections..... | 3-17 |
| Timing Specifications..... | 3-17 |
| Mode 1 Input Timing | 3-19 |
| Mode 1 Output Timing..... | 3-20 |
| Mode 2 Bidirectional Timing..... | 3-20 |
| Timing Connections | 3-22 |
| DAQ Timing Connections..... | 3-22 |
| General-Purpose Timing Signal Connections and | |
| General-Purpose Counter/Timer Signals..... | 3-26 |
| Digital I/O Signal Connections for the SCXIBus | 3-30 |

Chapter 4

Theory of Operation

| | |
|---|-----|
| Functional Overview | 4-1 |
| Analog Input and DAQ Circuitry | 4-2 |
| Analog Input Circuitry | 4-3 |
| DAQ Timing Circuitry | 4-4 |
| Single-Channel Data Acquisition..... | 4-5 |
| Multiple-Channel (Scanned) Data Acquisition | 4-5 |
| DAQ Rates | 4-6 |
| Analog Output Circuitry | 4-8 |

| | |
|---|------|
| Digital I/O Circuitry..... | 4-10 |
| Timing I/O Circuitry | 4-11 |
| SCXI Digital Interface | 4-14 |
| SCXI Scanning Modes | 4-15 |
| Single-Module Parallel Scanning..... | 4-15 |
| Multiple-Module Multiplexed Scanning..... | 4-15 |

Chapter 5

Calibration

| | |
|---|-----|
| Calibration at Higher Gains | 5-2 |
| Calibration Equipment Requirements..... | 5-3 |
| Using the Calibration Function..... | 5-3 |

Appendix A

Specifications

Appendix B

Installation Troubleshooting

Appendix C

Customer Communication

Glossary

Index

Figures

| | |
|--|------|
| Figure 1-1. The Relationship between the Programming Environment, NI-DAQ, and Your Hardware | 1-4 |
| Figure 2-1. SCXI-1200 Parts Locator Diagram..... | 2-4 |
| Figure 3-1. SCXI-1200 Front Connector Pin Assignments..... | 3-2 |
| Figure 3-2. SCXI-1200 Instrumentation Amplifier..... | 3-5 |
| Figure 3-3. Differential Input Connections for Grounded Signal Sources..... | 3-8 |
| Figure 3-4. Differential Input Connections for Floating Sources..... | 3-9 |
| Figure 3-5. Single-Ended Input Connections for Floating Signal Sources | 3-11 |
| Figure 3-6. Single-Ended Input Connections for Grounded Signal Sources..... | 3-12 |

| | | |
|--------------|---|------|
| Figure 3-7. | Analog Output Signal Connections | 3-14 |
| Figure 3-8. | Digital I/O Connections..... | 3-16 |
| Figure 3-9. | Mode 1 Timing Specifications for Input Transfers | 3-19 |
| Figure 3-10. | Mode 1 Timing Specifications for Output Transfers | 3-20 |
| Figure 3-11. | Mode 2 Timing Specification for Bidirectional Transfers | 3-21 |
| Figure 3-12. | EXTCONV* Signal Timing..... | 3-22 |
| Figure 3-13. | Posttrigger DAQ Timing Case 1 | 3-23 |
| Figure 3-14. | Posttrigger DAQ Timing Case 2 | 3-24 |
| Figure 3-15. | Pretrigger DAQ Timing..... | 3-25 |
| Figure 3-16. | EXTUPDATE* Signal Timing for Updating DAC Output | 3-26 |
| Figure 3-17. | Event-Counting Application with External Switch Gating | 3-27 |
| Figure 3-18. | Frequency Measurement Application | 3-28 |
| Figure 3-19. | General-Purpose Timing Signals..... | 3-29 |
| | | |
| Figure 4-1. | SCXI-1200 Block Diagram | 4-1 |
| Figure 4-2. | Analog Input and DAQ Circuitry Block Diagram | 4-3 |
| Figure 4-3. | Analog Output Circuitry Block Diagram | 4-9 |
| Figure 4-4. | Digital I/O Circuitry Block Diagram..... | 4-10 |
| Figure 4-5. | Timing I/O Circuitry Block Diagram | 4-12 |
| Figure 4-6. | Two-Channel Interval-Scanning Timing..... | 4-13 |
| Figure 4-7. | Single-Channel Interval Timing | 4-14 |
| Figure 4-8. | Digital Interface Circuitry Block Diagram..... | 4-14 |
| Figure 4-9. | Single-Module Parallel Scanning | 4-15 |
| Figure 4-10. | Multiple-Module Multiplexed Scanning Diagram | 4-16 |
| Figure 4-11. | SCXI Configurations | 4-17 |

Tables

| | | |
|------------|---|------|
| Table 2-1. | Analog I/O Settings | 2-5 |
| Table 2-2. | Analog Input Configurations for the SCXI-1200..... | 2-7 |
| Table 2-3. | Digital Signal Connections, Jumper Settings | 2-10 |
| | | |
| Table 3-1. | Recommended Input Configurations for Ground-Referenced and Floating Signal Sources | 3-7 |
| Table 3-2. | Port C Signal Assignments | 3-17 |
| | | |
| Table 4-1. | Analog Input Settling Time Versus Gain | 4-7 |
| Table 4-2. | SCXI-1200 Maximum Recommended DAQ Rates | 4-7 |
| Table 4-3. | Bipolar Analog Input Signal Range Versus Gain | 4-7 |
| Table 4-4. | Unipolar Analog Input Signal Range Versus Gain | 4-8 |

This manual describes the electrical and mechanical aspects of the SCXI-1200 module and contains information concerning its operation and programming. The SCXI-1200 is a member of the National Instruments Signal Conditioning eXtensions for Instrumentation (SCXI) Series modules. The SCXI-1200 is a combination DAQ and SCXI module that communicates with the PC through the parallel port.

Organization of This Manual

The *SCXI-1200 User Manual* is organized as follows:

- Chapter 1, *Introduction*, describes the SCXI-1200; lists the contents of your SCXI-1200 kit; describes the optional software, optional equipment, and custom cables; and explains how to unpack the SCXI-1200 kit.
- Chapter 2, *Installation and Configuration*, describes how to install the SCXI-1200 into the SCXI chassis and how to configure the SCXI-1200.
- Chapter 3, *Signal Connections*, describes the signal connections to the SCXI-1200 via the SCXI-1200 front connector and rear signal connector and includes specifications and connection instructions for the SCXI-1200 connector signals.
- Chapter 4, *Theory of Operation*, contains a functional overview of the SCXI-1200 module and explains the operation of each functional unit of the SCXI-1200.
- Chapter 5, *Calibration*, discusses the calibration of the SCXI-1200.
- Appendix A, *Specifications*, lists the specifications for the SCXI-1200.
- Appendix B, *Installation Troubleshooting*, contains installation troubleshooting information.
- Appendix C, *Customer Communication*, contains forms you can use to request help from National Instruments or to comment on our products.

- The *Glossary* contains an alphabetical list and description of terms used in this manual, including abbreviations, acronyms, metric prefixes, mnemonics, and symbols.
- The *Index* contains an alphabetical list of key terms and topics in this manual, including the page where you can find each one.

Conventions Used in This Manual

The following conventions appear in this manual:

| | |
|---------------------------|---|
| <> | Angle brackets containing numbers separated by an ellipsis represent a range of values associated with a bit or signal name (for example, BDIO<3..0>). |
| <i>bold italic</i> | Bold italic text denotes a note, caution, or warning. |
| DIO board | DIO board refers to the National Instruments AT-DIO-32F, MC-DIO-24, MC-DIO-32F, NB-DIO-24, NB-DIO-96, NB-DIO-32F, PC-DIO 24, and PC-DIO-96 digital I/O DAQ boards unless otherwise noted. |
| DIO-type board | DIO-type board refers to National Instruments DAQ boards that have only digital inputs and outputs. These boards include the DIO-24, DIO-32F, and DIO-96 boards unless otherwise noted. |
| <i>italic</i> | Italic text denotes emphasis, a cross reference, or an introduction to a key concept. |
| Lab board | Lab board refers to the National Instruments Lab-LC, Lab-NB, Lab-PC, and Lab-PC+ boards unless otherwise noted. |
| MIO board | MIO board refers to the National Instruments AT-MIO-16, AT-MIO-16D, AT-MIO-16F-5, AT-MIO-16X, AT-MIO-64F-5, MC-MIO-16, NB-MIO-16, and NB-MIO-16X multichannel I/O DAQ boards unless otherwise noted. |
| MIO-type board | MIO-type board refers to National Instruments DAQ boards that have at least analog and digital inputs and outputs. These boards include the MIO boards, the Lab boards, and the PC-LPM-16 board unless otherwise noted. |
| monospace | Lowercase text in this font denotes text or characters that are to be literally input from the keyboard, sections of code, programming examples, and syntax examples. This font is also used for the proper |

names of disk drives, paths, directories, programs, subprograms, subroutines, device names, functions, variables, filenames, and extensions, and for statements and comments taken from program code.

| | |
|---------|--|
| SCXIBus | SCXIBus refers to the backplane in the chassis. A signal on the backplane is referred to as the SCXIBus <signal name> line (or signal). The SCXIBus descriptor may be omitted when the meaning is clear. |
| Slot 0 | Slot 0 refers to the power supply and control circuitry in the SCXI chassis. |

The *Glossary* lists abbreviations, acronyms, metric prefixes, mnemonics, symbols, and terms.

National Instruments Documentation

The *SCXI-1200 User Manual* is one piece of the documentation set for your data acquisition and SCXI system. You can have any of several types of manuals, depending on the hardware and software in your system. Use the manuals you have as follows:

- *Getting Started with SCXI*—This is the first manual you should read. It gives an overview of the SCXI system and contains the most commonly needed information for the modules, chassis, and software.
- Your SCXI hardware user manuals—Read these manuals next for detailed information about signal connections and module configuration. They also explain in greater detail how the module works and contain application hints.
- Your DAQ hardware user manuals—These manuals have detailed information about the DAQ hardware that plugs into your computer. Use these manuals for hardware installation and configuration instructions, specification information about your DAQ hardware, and application hints.
- Software manuals—Examples of software manuals you may have are the LabVIEW and LabWindows®/CVI documentation sets and the NI-DAQ documentation. After you set up your hardware system, use either the application software (LabVIEW or LabWindows/CVI) or the NI-DAQ documentation to help you write your application. If you have a large, complicated system, it is worthwhile to look through the software manuals before you configure your hardware.

- Accessory installation guides or manuals—If you are using accessory products, read the terminal block and cable assembly installation guides or accessory board user manuals. They explain how to physically connect the relevant pieces of the system. Consult these guides when you are making your connections.
- *SCXI Chassis User Manual*—Read this manual for maintenance information on the chassis and for installation instructions.

Related Documentation

The following National Instruments manual contains detailed information for the register-level programmer.

- *SCXI-1200 Register-Level Programmer Manual*

This manual is available from National Instruments by request. If you are using NI-DAQ, LabVIEW, or LabWindows/CVI, you should not need the register-level programmer manual. Using NI-DAQ, LabVIEW, or LabWindows/CVI is as easy as using the low-level programming described in the register-level programmer manual. Refer to *Software Programming Choices* in Chapter 1, *Introduction*, of this manual to learn more about your programming options.

Customer Communication

National Instruments wants to receive your comments on our products and manuals. We are interested in the applications you develop with our products, and we want to help if you have problems with them. To make it easy for you to contact us, this manual contains comment and configuration forms for you to complete. These forms are in Appendix C, *Customer Communication*.

Introduction

Chapter

1

This chapter describes the SCXI-1200; lists the contents of your SCXI-1200 kit; describes the optional software, optional equipment, and custom cables; and explains how to unpack the SCXI-1200 kit.

About the SCXI-1200

Thank you for buying the National Instruments SCXI-1200. The SCXI-1200 is an SCXI module that works like the Lab-PC+ multifunction analog, digital, and timing I/O plug-in board. You can use the SCXI-1200 in conjunction with other SCXI modules or as a stand-alone module. The SCXI-1200 module communicates with the PC through the parallel port and works with the four-slot SCXI-1000, the four-slot DC powered SCXI-1000DC, and the twelve-slot SCXI-1001 chassis.

With the SCXI-1200, you can use a Remote SCXI configuration with an SCXI-2000 remote chassis or you can use either an SCXI-1000 chassis, an SCXI-1001 chassis or an SCXI-1000 DC chassis outfitted with an SCXI-2400 communications module. If you are using the second option, you need to connect a serial port cable (either RS-232 or RS-485) to the SCXI-2000 chassis or the SCXI-2400 module, and a short parallel port cable from the SCXI-2000 or SCXI-2400 to the back of the SCXI-1200 module. This short parallel port cable is included with the SCXI-2000 remote chassis and the SCXI-2400 remote communications module. As a stand-alone module, the SCXI-1200 has eight analog input channels, that can be configured as eight single-ended or four differential; a 12-bit successive-approximation ADC; two 12-bit DACs with voltage outputs; 24 lines of TTL-compatible digital I/O; and 16-bit counter/timer channels for timing I/O.

The SCXI-1200 works with other National Instruments SCXI modules and can operate in a single-chassis system. The SCXI-1200 controls the operation of and digitizes the conditioned analog signals from other SCXI modules.

The SCXI-1200 complies with IEEE 1284. This IEEE protocol supports three different parallel port types—the original Centronics or unidirectional port for printers, the PS2 type bidirectional port, and the 386-SL Enhanced Parallel Port (EPP).

A shielded terminal block, the SCXI-1302, has screw terminals for easy signal attachment to the SCXI-1200.

With the SCXI-1200, the SCXI chassis can serve as a DAQ solution for slotless computers, such as laptops, as well as PCs with parallel ports or serial ports.

Detailed specifications of the SCXI-1200 are in Appendix A, *Specifications*.

What You Need to Get Started

To set up and use your SCXI-1200, you will need the following:

- SCXI-1200 module
- SCXI-1200 User Manual*
- One of the following software packages and documentation:
 - NI-DAQ for PC compatibles
 - LabVIEW for Windows
 - LabWindows/CVI
- Parallel port cable (1 m)
- Your computer



Note: *If you are using Remote SCXI, use the parallel port cable that is included with the Remote SCXI unit.*

Software Programming Choices

There are several options to choose from when programming your National Instruments DAQ and SCXI hardware. You can use LabVIEW, LabWindows/CVI, NI-DAQ, or register-level programming.

LabVIEW and LabWindows/CVI Application Software

LabVIEW and LabWindows/CVI are innovative program development software packages for data acquisition and control applications. LabVIEW uses graphical programming, whereas LabWindows/CVI enhances traditional programming languages. Both packages include extensive libraries for data acquisition, instrument control, data analysis, and graphical data presentation.

LabVIEW features interactive graphics, a state-of-the-art user interface, and a powerful graphical programming language. The LabVIEW Data Acquisition VI Library, a series of VIs for using LabVIEW with National Instruments DAQ hardware, is included with LabVIEW. The LabVIEW Data Acquisition VI Library is functionally equivalent to the NI-DAQ software.

LabWindows/CVI features interactive graphics, a state-of-the-art user interface, and uses the ANSI standard C programming language. The LabWindows/CVI Data Acquisition Library, a series of functions for using LabWindows/CVI with National Instruments DAQ hardware, is included with the NI-DAQ software kit. The LabWindows/CVI Data Acquisition Library is functionally equivalent to the NI-DAQ software.

Using LabVIEW or LabWindows/CVI software will greatly reduce the development time for your data acquisition and control application.



Note: *The DAQ interface for LabWindows for DOS does not support the use of Remote SCXI.*

NI-DAQ Driver Software

The NI-DAQ driver software is included at no charge with all National Instruments DAQ hardware. NI-DAQ is not packaged with SCXI or accessory products. NI-DAQ has an extensive library of functions that you can call from your application programming environment. These functions include routines for analog input (A/D conversion), buffered data acquisition (high-speed A/D conversion), analog output (D/A conversion), waveform generation (timed D/A conversion), digital I/O, counter/timer operations, SCXI, RTSI, self-calibration, messaging, and acquiring data to extended memory.

NI-DAQ has both high-level DAQ I/O functions for maximum ease of use and low-level DAQ I/O functions for maximum flexibility and performance. Examples of high-level functions are streaming data to disk or acquiring a certain number of data points. An example of a

low-level function is writing directly to registers on the DAQ device. NI-DAQ does not sacrifice the performance of National Instruments DAQ devices because it lets multiple devices operate at their peak.

NI-DAQ also internally addresses many of the complex issues between the computer and the DAQ hardware such as programming interrupts and DMA controllers. NI-DAQ maintains a consistent software interface among its different versions so that you can change platforms with minimal modifications to your code. Whether you are using conventional programming languages, LabVIEW, or LabWindows/CVI, your application uses the NI-DAQ driver software, as illustrated in Figure 1-1.

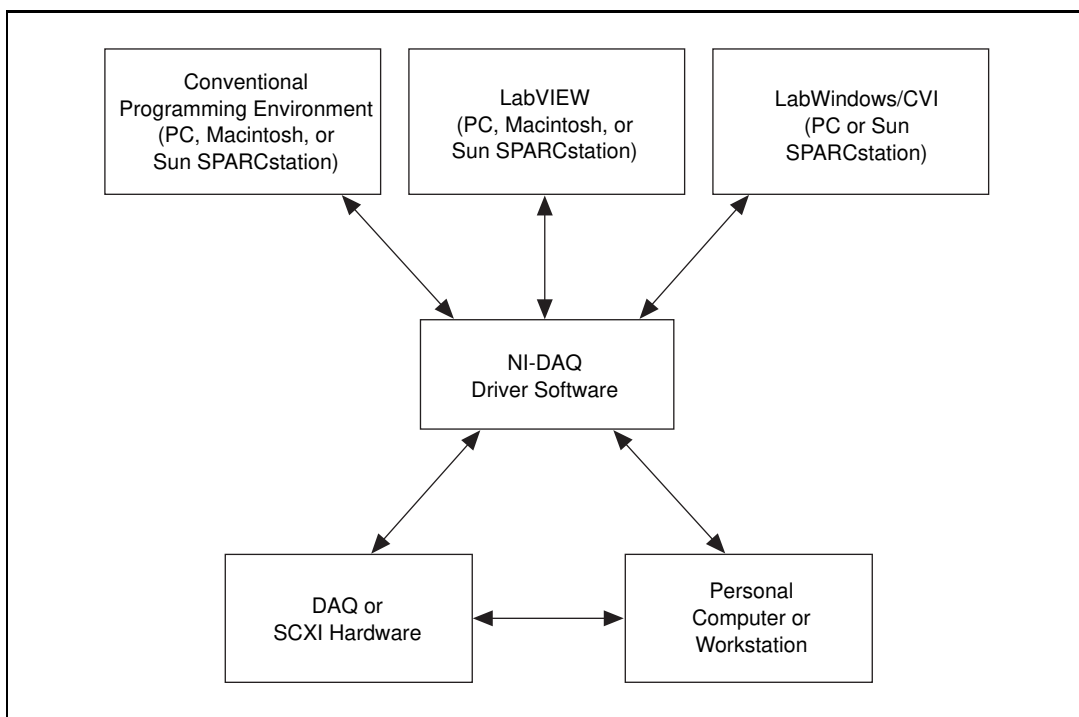

Figure 1-1. The Relationship between the Programming Environment, NI-DAQ, and Your Hardware

Register-Level Programming

The final option for programming any National Instruments DAQ hardware is to write register-level software. Writing register-level

programming software can be very time-consuming and inefficient, and is not recommended for most users.

Even if you are an experienced register-level programmer, consider using NI-DAQ, LabVIEW, or LabWindows/CVI to program your National Instruments DAQ hardware. Using the NI-DAQ, LabVIEW, or LabWindows/CVI software is easier than, and as flexible as, register-level programming and can save you weeks of development time.



Note: *If you are using the SCXI-1200 with Remote SCXI, you cannot do register-level programming.*

Optional Equipment

You can use the following National Instruments products with your SCXI-1200:

- SCXI-1302 front terminal block
- CB-50 I/O connector block
- Type NB1 0.5 or 1.0 m ribbon cable

For more information about optional equipment available from National Instruments, refer to your National Instruments catalogue or call the office nearest you.

Custom Cables

The SCXI-1200 front signal connector is a 50-pin male ribbon-cable header. The manufacturer part number of the header National Instruments uses is as follows:

- AMP Inc. (part number 1-103310-0)

The mating connector for the SCXI-1200 rear signal connector is a 50-position polarized ribbon-socket connector with strain relief. National Instruments uses a polarized or keyed connector to prevent inadvertent upside-down connection to the SCXI-1200.

Recommended manufacturer part numbers for this mating connector are as follows:

- Electronic Products Division/3M (part number 3425-7650)
- T&B/Ansley Corporation (part number 609-5041CE)

Standard 50-conductor 28 AWG stranded ribbon cables that work with these connectors are as follows:

- Electronic Products Division/3M (part number 3365/50)
- T&B/Ansley Corporation (part number 171-50)

The SCXI-1200 rear connector (the parallel port connector) is the standard 25-pin D-Subminiature. The manufacturer part number of the connector National Instruments uses is as follows:

- AMP Inc. (part number 747846-5)

The mating connector for the SCXI-1200 rear connector can be a standard DB-25-style male connector.

Unpacking

Your SCXI-1200 module is shipped in an antistatic package to prevent electrostatic damage to the module. Electrostatic discharge can damage several components on the module. To avoid such damage in handling the module, take the following precautions:

- Ground yourself via a grounding strap or by holding a grounded chassis such as your SCXI chassis.
- Touch the antistatic package to a metal part of your SCXI chassis before removing the module from the package.
- Remove the module from the package and inspect the module for loose components or any other sign of damage. Notify National Instruments if the module appears damaged in any way. *Do not* install a damaged module into your SCXI chassis.
- *Never* touch the exposed pins of connectors.

Installation and Configuration

Chapter

2

This chapter describes how to install the SCXI-1200 into the SCXI chassis and how to configure the SCXI-1200.

The SCXI-1200 combines the functionality of plug-in DAQ boards and SCXI modules. Previously, you connected the SCXI chassis with a ribbon cable to a plug-in board in the PC. Any SCXI module in the chassis could be used for this purpose. Now you can use the SCXI-1200 as a plug-in module that connects to the PC parallel port.

Hardware Installation

You can install the SCXI-1200 in any available SCXI chassis slot. After you have made any necessary changes and have verified and recorded the jumper setting on the form in Appendix C, *Customer Communication*, you are ready to install the SCXI-1200. The following are general installation instructions; consult your chassis user manual or technical reference manual for specific instructions and warnings.

1. Turn off the SCXI chassis. Do not insert the SCXI-1200 into a chassis that is turned on.
2. Insert the SCXI-1200 into the module guides. Gently guide the module into the back of the slot until the connectors make contact.
3. Screw the front mounting panel of the SCXI-1200 to the top and bottom threaded strips of your SCXI chassis.
4. If you are using Remote SCXI, connect the 25-pin DSUB end of the short parallel port cable to the back of the SCXI-1200 and connect the 36-pin end of the cable to the parallel port of the SCXI-2000 chassis or SCXI-2400 module adapter board. Then, connect a serial port cable between the SCXI-2000 chassis or SCXI-2400 module adapter board and the serial port of your PC.

If you are not using Remote SCXI, connect one of the 25-pin D SUB ends of the parallel port cable to the PC parallel port and the other end to the back of the SCXI-1200. Screw in the mounting screws on the connectors to establish a firm connection.

5. If you are using Remote SCXI, set the desired baud rate and chassis address by setting the DIP switches. For more information, refer to the *SCXI Chassis User Manual* or the *SCXI-2400 User Manual*.
If you are using an SCXI-1000 chassis with jumper-selectable addresses (Rev E or later) or an SCXI-1001 chassis, set the jumpers to the desired chassis address.
6. Visually verify the installation.
7. Turn on the SCXI chassis.
8. Turn on the computer or reconnect it to your chassis.

The SCXI-1200 board is installed. You are now ready to install and configure your software.

If you are using NI-DAQ, refer to your NI-DAQ release notes. Find the installation and system configuration section for your operating system and follow the instructions given there.

If you are using LabVIEW, the software installation instructions are in your LabVIEW release notes.

If you are using LabWindows/CVI, the software installation instructions are in your LabWindows/CVI release notes.

If you are a register-level programmer, refer to the *SCXI-1200 Register-Level Programmer Manual*.

Module Configuration

The SCXI-1200 is software calibrated and software configurable. Seven bits in the SCXI-1200 control registers configure all of the analog I/O options. If you use NI-DAQ software, these bits are automatically set or reset based on your configuration.

The SCXI-1200 has one reserved jumper, which selects the grounding scheme for the SCXIbus guard. The parts locator diagram in Figure 2-1 shows the SCXI-1200 jumper (W1). If you are using Remote SCXI, you do not need to allocate any PC hardware resources specifically for the SCXI-1200 module. For more information on setting up your Remote SCXI configuration, refer to the *Getting Started with SCXI Manual*, the *SCXI Chassis User Manual*, or the *SCXI-2400 User Manual*.

Direct Parallel Port Connection to PC

An IBM-compatible PC can support up to three parallel printer ports, which are designated LPT1, LPT2 and LPT3. Each port uses three consecutive I/O addresses. When you boot your system, DOS assigns the printer ports to the logical LPT designations, in the following order: LPT1, LPT2, and LPT3. The starting addresses of the parallel printer ports, in the order assigned to LPT designations, are 3BC, 378, and 278 hex. Therefore, if you have installed all three ports, 3BC hex is LPT1, 378 hex is LPT2, and 278 hex is LPT3. If you have not installed port 3BC hex, port 378 hex becomes LPT1 and port 278 hex becomes LPT2. If only one parallel port is present, it is LPT1.

The SCXI-1200 uses the parallel port hardware interrupts for interrupt-driven data acquisition. Interrupt channels 7 and 5 are commonly allocated to parallel ports. Refer to your computer technical reference manual for details about the parallel port base address and its interrupt selection.

If you use the SCXI-1200 with NI-DAQ software, you select the port and interrupt at configuration time.

The configuration utility displays on-screen all the parallel ports addresses that were detected at boot-up. You must then select the port address that you have connected to the SCXI-1200. You must also select the interrupt level of the port. When you try to save these settings, they will be tested and verified. Also, the type of parallel port (Enhanced or Centronics) will be reported. If you incorrectly specify the port address or interrupt, then an error will be reported. Refer to Appendix B, *Installation Troubleshooting*, for tips on troubleshooting.

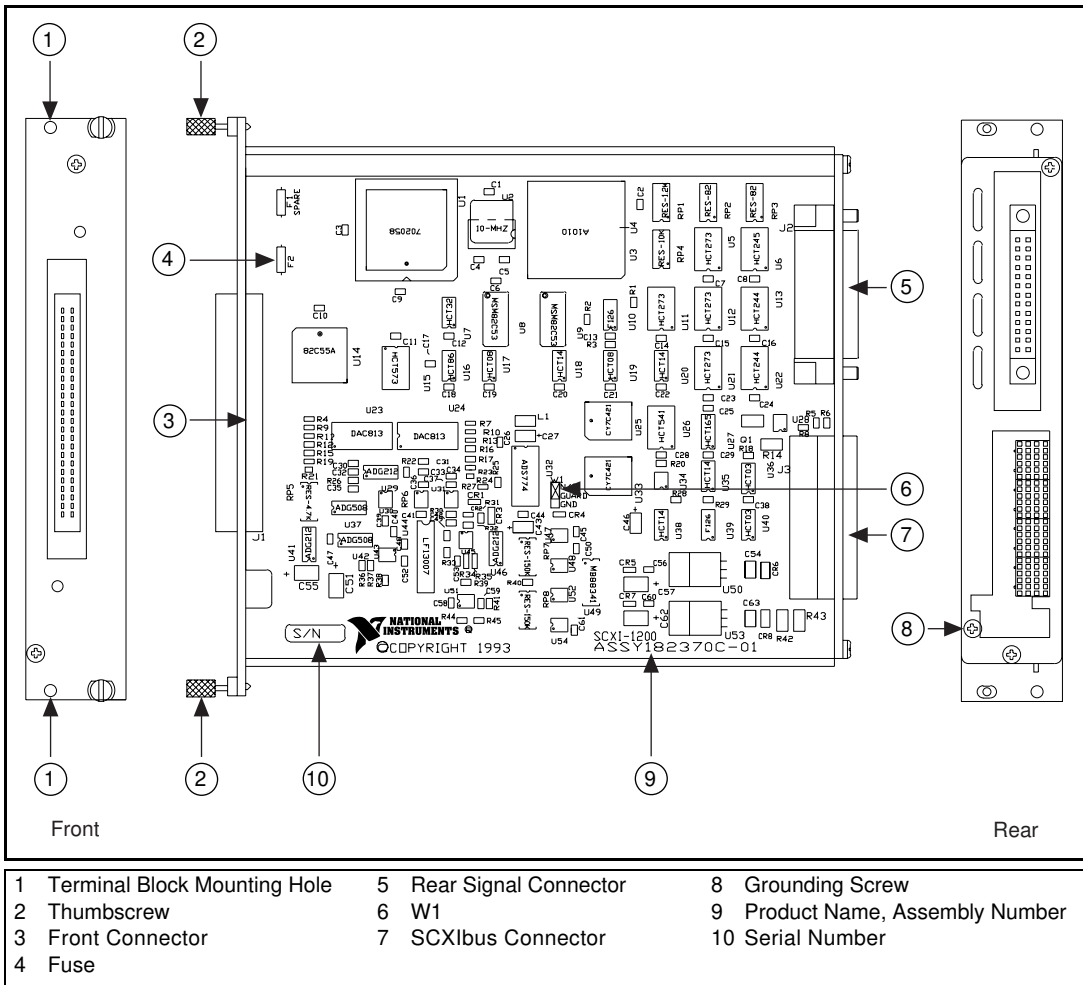

Figure 2-1. SCXI-1200 Parts Locator Diagram

The following warnings contain important safety information concerning hazardous voltages.



Warnings: *KEEP AWAY FROM LIVE CIRCUITS. Do not remove equipment covers or shields unless you are trained to do so. If signal wires are connected to the module or terminal block, dangerous voltages may exist even when the equipment is turned off. To avoid dangerous electrical shock, do not perform procedures involving cover or shield removal unless you are qualified to do so.*

DO NOT OPERATE DAMAGED EQUIPMENT. *The safety-protection features built into this module can become impaired if the module becomes damaged in any way. If it is damaged, turn the module off and do not use it until service-trained personnel can check its safety. If necessary, return the module to National Instruments for service and repair to ensure that its safety is not compromised.*

DO NOT SUBSTITUTE PARTS OR MODIFY EQUIPMENT. *Because of the danger of introducing additional hazards, do not install unauthorized parts or modify the module. Return the module to National Instruments for service and repair to ensure that its safety features are not compromised.*

Analog I/O Configuration

The SCXI-1200 is shipped from the factory with the following configuration:

- Referenced single-ended input mode
- ± 5 V analog input range (bipolar)
- ± 5 V analog output range (bipolar)

Table 2-1 lists all the available analog I/O bit configurations for the SCXI-1200 and shows the factory settings.

Table 2-1. Analog I/O Settings

| Parameter | Configuration |
|----------------------------|--|
| Analog Output CH0 Polarity | Bipolar— ± 5 V (factory setting) Unipolar—0 to 10 V |
| Analog Output CH1 Polarity | Bipolar— ± 5 V (factory setting) Unipolar—0 to 10 V |
| Analog Input Range | Bipolar— ± 5 V (factory setting) Unipolar—0 to 10 V |
| Analog Input Mode | Referenced single-ended (RSE) (factory setting) Non-referenced single-ended (NRSE) Differential (DIFF) Analog Bus 0 (SCXI) |

Both the analog input and analog output circuitries are software configurable.

Analog Output Configuration

The SCXI-1200 has two channels of analog output voltage at the I/O connector. You can configure each analog output channel for either unipolar or bipolar output. A unipolar configuration has a range of 0 to 10 V at the analog output. A bipolar configuration has a range of -5 V to +5 V at the analog output. In addition, you can select the coding scheme for each DAC as either two's complement or straight binary.

If you select a bipolar range for a DAC, the two's complement coding is recommended. In this mode, data values written to the analog output channel range from F800 hex (-2,048 decimal) to 7FF hex (2,047 decimal). If you select a unipolar range for a DAC, the straight binary coding is recommended. In this mode, data values written to the analog output channel range from 0 to FFF hex (4,095 decimal).

Analog Input Configuration

Input Mode

The SCXI-1200 has three different input modes—referenced single-ended (RSE) input, non-referenced single-ended (NRSE) input, and differential (DIFF) input. The single-ended input configurations use eight channels. The DIFF input configuration uses four channels. Table 2-2 describes these configurations.

Table 2-2. Analog Input Configurations for the SCXI-1200

| Configuration | Description |
|---------------|--|
| RSE | Referenced single-ended configuration provides eight single-ended inputs with the negative input of the instrumentation amplifier referenced to analog ground (factory setting). |
| NRSE | Non-referenced single-ended configuration provides eight single-ended inputs with the negative input of the instrumentation amplifier tied to AISENSE/AIGND and not connected to ground. |
| DIFF | Differential configuration provides four differential inputs with the positive (+) input of the instrumentation amplifier tied to channels 0, 2, 4, or 6 and the negative (-) input tied to channels 1, 3, 5, or 7, respectively, thus choosing channel pairs (0, 1), (2, 3), (4, 5), or (6, 7). |

In addition, the input circuitry can select the SCXI Analog Bus 0 when you are using the SCXI-1200 to sample data output by some other module. On power-up, the AB0 bus is not selected. Refer to the *SCXI-1200 Register-Level Programmer Manual* or your software manual for details on how to use the multiplexed module mode. When Analog Bus 0 is selected by the input circuitry, the DIFF mode is always used. Analog Bus 0+ is tied to the positive (+) input of the instrumentation amplifier. Analog Bus 0- is tied to the negative (-) input of the instrumentation amplifier. In this case, the input mode settings (RSE, NRSE, or DIFF) have no effect. However, the gain and unipolar/bipolar settings are still valid.

While reading the following paragraphs, you may find it helpful to refer to the *Analog Input Signal Connections* section of Chapter 3, *Signal Connections*, which contains diagrams showing the signal paths for the three configurations.

RSE Input (Eight Channels, Factory Setting)

RSE input means that all input signals are referenced to a common ground point that is also tied to the SCXI-1200 analog input ground. The differential amplifier negative input is tied to analog ground. The RSE configuration is useful for measuring floating signal sources. See *Types of Signal Sources* in Chapter 3, *Signal Connections*, for more information. With this input configuration, the SCXI-1200 can monitor eight different analog input channels.

Considerations for using the RSE configuration are discussed in Chapter 3, *Signal Connections*. Notice that in this mode, the return path of the signal is analog ground, at the connector through the AISENSE/AIGND pin.

NRSE Input (Eight Channels)

NRSE input means that all input signals are referenced to the same common-mode voltage, which floats with respect to the SCXI-1200 analog ground. This common-mode voltage is subsequently subtracted by the input instrumentation amplifier. The NRSE configuration is useful for measuring ground-referenced signal sources.

Considerations for using the NRSE configuration are discussed in Chapter 3, *Signal Connections*. Notice that in this mode, the return path of the signal is through the negative terminal of the amplifier, at the connector through the AISENSE/AIGND pin.

DIFF Input (Four Channels)

DIFF input means that each input signal has its own reference, and the difference between each signal and its reference is measured. The signal and its reference are each assigned an input channel. With this input configuration, the SCXI-1200 can monitor four differential analog input signals.

Considerations for using the DIFF configuration are discussed in Chapter 3, *Signal Connections*. Notice that the signal return path is through the negative terminal of the amplifier and through channel 1, 3, 5, or 7, depending on which channel pair you select.

These three modes are all software selectable.

Analog Input Polarity and Range Configuration

You can select the analog input on the SCXI-1200 for either a unipolar range (0 to 10 V) or a bipolar range (-5 to +5 V). The range and the coding scheme are both software selectable. In addition, you can select the coding scheme for analog input as either two's complement or straight binary. If you select a bipolar range, the two's complement coding is recommended. In this mode, -5 V input corresponds to F800 hex (-2,048 decimal) and +5 V corresponds to 7FF hex (2,047 decimal). If you select a unipolar mode, the straight binary coding is recommended. In this mode, 0 V input corresponds to 0 hex, and +10 V corresponds to FFF hex (4,095 decimal).



Note: *If Analog Bus 0 is selected by the SCXI-1200, this selection is still valid. If another module is in unipolar mode and drives Analog Bus 0, the SCXI-1200 must also be in unipolar mode.*

SCXI Configuration

The SCXI configuration circuitry is software configurable with the configuration utility. There is also one jumper, as shown in Table 2-3.

When used in the stand-alone mode, the EXTCONV* and COUTB1 lines on the front connector can be driven with suitable signals for causing external conversions and for interval scanning, respectively. When used in conjunction with other modules (the SCXI mode), the SCXI-1200 drives these pins with its own signals. These signals are also routed through the SCXI bus and to other modules. The other modules synchronize the switching of their input channels according to these signals.

You use jumper J1 for grounding the SCXI guard to analog ground on the SCXI-1200. The position of this jumper is shown in Table 2-3. When used in stand-alone mode, this jumper should be in the default (A-B) setting. When used in conjunction with other modules, the jumper must be in the B-C setting.

Refer to the parts locator diagram in Figure 2-1 as you read the following instructions. To configure this jumper, perform the following steps:

1. Remove the grounding screw of the top cover.
2. Snap out the top cover of the shield by placing a screwdriver in the groove at the bottom of the module.

3. Remove the jumper and replace it on the appropriate pins.
4. Snap the top cover back in place.
5. Replace the grounding screw to ensure proper shielding.

Table 2-3 describes the jumper settings for different configurations.

Table 2-3. Digital Signal Connections, Jumper Settings

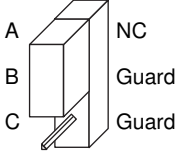
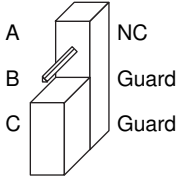
| Jumper W1 Settings | Description |
|---|--|
|  | <p>Position A-B (factory setting)—The SCXI Analog Bus guard is not connected to the SCXI-1200 analog ground. When using the SCXI-1200 in stand-alone mode, use this setting.</p> |
|  | <p>Position B-C—The SCXI Analog Bus guard is connected to the SCXI-1200 analog ground. When using the SCXI-1200 in conjunction with other modules, use this setting.</p> |

Signal Connections

Chapter

3

This chapter describes the signal connections to the SCXI-1200 module via the SCXI-1200 front connector and rear signal connector and includes specifications and connection instructions for the SCXI-1200 connector signals.



Warning: *Connections that exceed any of the maximum ratings of input or output signals on the SCXI-1200 can damage the SCXI-1200 module and the computer. This includes connecting any power signals to ground and vice versa. The description of each signal in this section includes information about maximum input ratings. National Instruments is NOT liable for any damages resulting from such signal connections.*

Front Connector

Figure 3-1 shows the pin assignments for the SCXI-1200 front connector. This connector is located on the front panel of the SCXI-1200 module.

| | | | |
|---------------|----|----|----------|
| ACH0 | 1 | 2 | ACH1 |
| ACH2 | 3 | 4 | ACH3 |
| ACH4 | 5 | 6 | ACH5 |
| ACH6 | 7 | 8 | ACH7 |
| AISENSE/AIGND | 9 | 10 | DAC0OUT |
| AGND | 11 | 12 | DAC1OUT |
| DGND | 13 | 14 | PA0 |
| PA1 | 15 | 16 | PA2 |
| PA3 | 17 | 18 | PA4 |
| PA5 | 19 | 20 | PA6 |
| PA7 | 21 | 22 | PB0 |
| PB1 | 23 | 24 | PB2 |
| PB3 | 25 | 26 | PB4 |
| PB5 | 27 | 28 | PB6 |
| PB7 | 29 | 30 | PC0 |
| PC1 | 31 | 32 | PC2 |
| PC3 | 33 | 34 | PC4 |
| PC5 | 35 | 36 | PC6 |
| PC7 | 37 | 38 | EXTTRIG |
| EXTUPDATE* | 39 | 40 | EXTCONV* |
| OUTB0 | 41 | 42 | GATB0 |
| OUTB1 | 43 | 44 | GATB1 |
| CLKB1 | 45 | 46 | OUTB2 |
| GATB2 | 47 | 48 | CLKB2 |
| +5 V | 49 | 50 | DGND |

Figure 3-1. SCXI-1200 Front Connector Pin Assignments

Front Connector Signal Connection Descriptions

The following table describes the connector pins on the SCXI-1200 front connector by pin number and gives the signal name and the significance of each signal connector pin.

| Pin | Signal Name | Description |
|-------|---------------|--|
| 1-8 | ACH<0..7> | Analog Channel—Analog Input channels 0 through 7 (single-ended). |
| 9 | AISENSE/AIGND | Analog Input Sense/Analog Input Ground—Analog input ground in RSE mode, AISENSE in NRSE mode. Bidirectional. |
| 10 | DAC0OUT | Digital-to-Analog Converter 0 Output—Voltage output signal for analog output channel 0. |
| 11 | AGND | Analog Ground—Analog output ground for analog output mode. Analog input ground for DIFF or NRSE mode. Bidirectional. |
| 12 | DAC1OUT | Digital-to-Analog Converter 1 Output—Voltage output signal for analog output channel 1. |
| 13 | DGND | Digital Ground—Bidirectional. |
| 14-21 | PA<0..7> | Port A 0 through 7—Bidirectional data lines for port A. PA7 is the MSB, and PA0 is the LSB. |
| 22-29 | PB<0..7> | Port B 0 through 7—Bidirectional data lines for port B. PB7 is the MSB, and PB0 is the LSB. |
| 30-37 | PC<0..7> | Port C 0 through 7—Bidirectional data lines for port C. PC7 is the MSB, and PC0 is the LSB. |
| 38 | EXTTRIG | External Trigger—External control signal to start a timed conversion sequence. Input. |
| 39 | EXTUPDATE* | External Update—External control signal to update DAC outputs. Input. |
| 40 | EXTCONV* | External Convert—External control signal to trigger A/D conversions when selected as input. Outputs conditioned conversion pulse when selected as output. Bidirectional. |
| 41 | OUTB0 | Counter B0 Output—Output. |
| 42 | GATB0 | Counter B0 Gate—Input. |

| Pin | Signal Name | Description |
|---|-------------|--|
| 43 | OUTB1 | Counter B1 Output—Counter B1 output used as HOLDTRIG for SCXI use. Pulled high for user-driven interval scanning input signal. |
| 44 | GATB1 | Counter B1 Gate—Input. |
| 45 | CLKB1 | Counter B1 Clock—Input (selectable). |
| 46 | OUTB2 | Counter B2—Output. |
| 47 | GATB2 | Counter B2 Gate—Input. |
| 48 | CLKB2 | Counter B2 Clock—Input. |
| 49 | +5 V | +5 V output, fused at 1 A. |
| 50 | DGND | Digital Ground—Output. |
| *Indicates that the signal is active low. | | |

The connector pins are grouped into analog input signal pins, analog output signal pins, digital I/O signal pins, timing I/O signal pins and SCXIBus control pins. Signal connection guidelines for each of these groups are described in the following sections.

Analog Input Signal Connections

Pins 1 through 8 are analog input signal pins for the 12-bit ADC. Pin 9, AISENSE/AIGND, is an analog common signal. You can use this pin for a general analog power ground tie to the SCXI-1200 in RSE mode, or as a return path in DIFF or NRSE mode. Pins 1 through 8 are tied to the eight single-ended analog input channels of the input multiplexer through 4.7 k Ω series resistances. Pins 2, 4, 6 and 8 are also tied to an input multiplexer for DIFF mode.

The following input ranges and maximum ratings apply to inputs ACH<0..7>:

- Input signal range
 - Bipolar input $\pm(5/\text{gain})$ V
 - Unipolar input 0 to $(10/\text{gain})$ V
- Maximum input voltage rating ± 42 V powered on or off



Warning: *Exceeding the input signal range results in distorted input signals. Exceeding the maximum input voltage rating may cause damage to the SCXI-1200 module and to the computer. National Instruments is NOT liable for any damages resulting from such signal connections.*

How you connect analog input signals to the SCXI-1200 depends on how you configure the SCXI-1200 analog input circuitry and the type of input signal source. With different SCXI-1200 configurations, you can use the SCXI-1200 instrumentation amplifier in different ways. Figure 3-2 shows a diagram of the SCXI-1200 instrumentation amplifier.

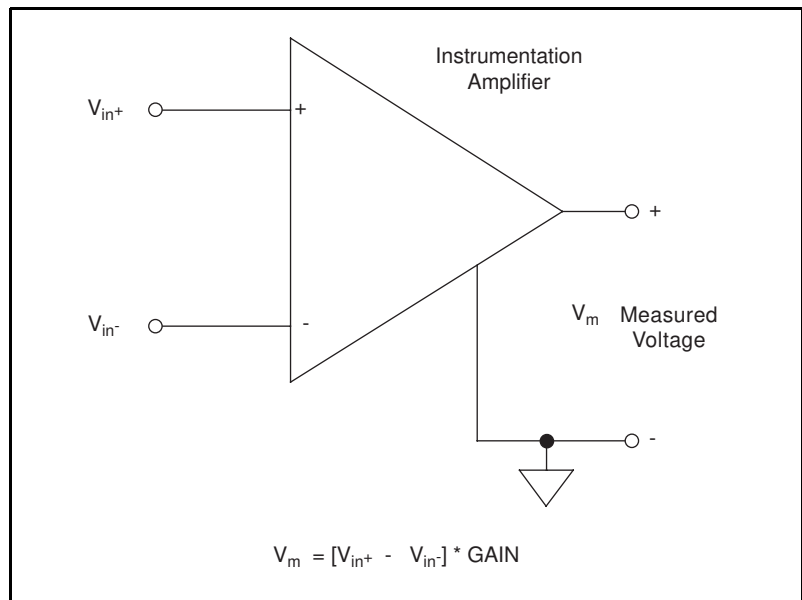

Figure 3-2. SCXI-1200 Instrumentation Amplifier

The SCXI-1200 instrumentation amplifier applies gain, common-mode voltage rejection, and high-input impedance to the analog input signals connected to the SCXI-1200 module. Signals are routed to the positive and negative inputs of the instrumentation amplifier through input multiplexers on the SCXI-1200. The instrumentation amplifier converts two input signals to a signal that is the difference between the two input signals multiplied by the gain setting of the amplifier. The amplifier output voltage is referenced to the SCXI-1200 ground. The SCXI-1200 ADC measures this output voltage when it performs A/D conversions.

All signals must be referenced to ground, either at the source device or at the SCXI-1200. If you have a floating source, you must use a ground-referenced input connection at the SCXI-1200. If you have a grounded source, you must use a nonreferenced input connection at the SCXI-1200.

Types of Signal Sources

When configuring the input mode of the SCXI-1200 and making signal connections, you must first determine whether the signal source is floating or ground referenced. These two types of signals are described as follows.

Floating Signal Sources

A floating signal source is not connected in any way to the building ground system but has an isolated ground-reference point. Some examples of floating signal sources are outputs of transformers, thermocouples, battery-powered devices, optical isolator outputs, and isolation amplifiers. You must tie the ground reference of a floating signal to the SCXI-1200 analog input ground to establish a local or onboard reference for the signal. Otherwise, the measured input signal varies or appears to float. An instrument or device that supplies an isolated output falls into the floating signal source category.

Ground-Referenced Signal Sources

A ground-referenced signal source is connected in some way to the building system ground and is therefore already connected to a common ground point with respect to the SCXI-1200, assuming that the PC is plugged into the same power system. Nonisolated outputs of instruments and devices that plug into the building power system fall into this category.

The difference in ground potential between two instruments connected to the same building power system is typically between 1 mV and 100 mV but can be much higher if power distribution circuits are not properly connected. The connection instructions that follow for grounded signal sources eliminate this ground potential difference from the measured signal.

Input Configurations

You can configure the SCXI-1200 for one of three input modes—RSE, NRSE, or DIFF. The following sections discuss the use of single-ended and differential measurements, and considerations for measuring both floating and ground-referenced signal sources. Table 3-1 summarizes the recommended input configurations for both types of signal sources.

Table 3-1. Recommended Input Configurations for Ground-Referenced and Floating Signal Sources

| Type of Signal | Recommended Input Configuration |
|--|---------------------------------|
| Ground-Referenced (nonisolated outputs, plug-in instruments) | DIFF NRSE |
| Floating (batteries, thermocouples, isolated outputs) | DIFF with bias resistors RSE |

Differential Connection Considerations (DIFF Configuration)

Differential connections are those in which each SCXI-1200 analog input signal has its own reference signal or signal return path. These connections are available when you configure the SCXI-1200 in the DIFF mode. Each input signal is tied to the positive input of the instrumentation amplifier, and its reference signal, or return, is tied to the negative input of the instrumentation amplifier.

When you configure the SCXI-1200 for DIFF input, each signal uses two of the multiplexer inputs—one for the signal and one for its reference signal. Therefore, only four analog input channels are available when using the DIFF configuration. You should use the DIFF input configuration when any of the following conditions are present:

- Input signals are low level (less than 1 V).
- Leads connecting the signals to the SCXI-1200 are greater than 15 ft.
- Any of the input signals requires a separate ground-reference point or return signal.
- The signal leads travel through noisy environments.

Differential signal connections reduce picked-up noise and increase common-mode signal and noise rejection. With these connections, input signals can float within the common-mode limits of the input instrumentation amplifier.

Differential Connections for Grounded Signal Sources

Figure 3-3 shows how to connect a ground-referenced signal source to an SCXI-1200 module configured for DIFF input. Configuration instructions are included in the *Analog Input Configuration* section in Chapter 2, *Installation and Configuration*.

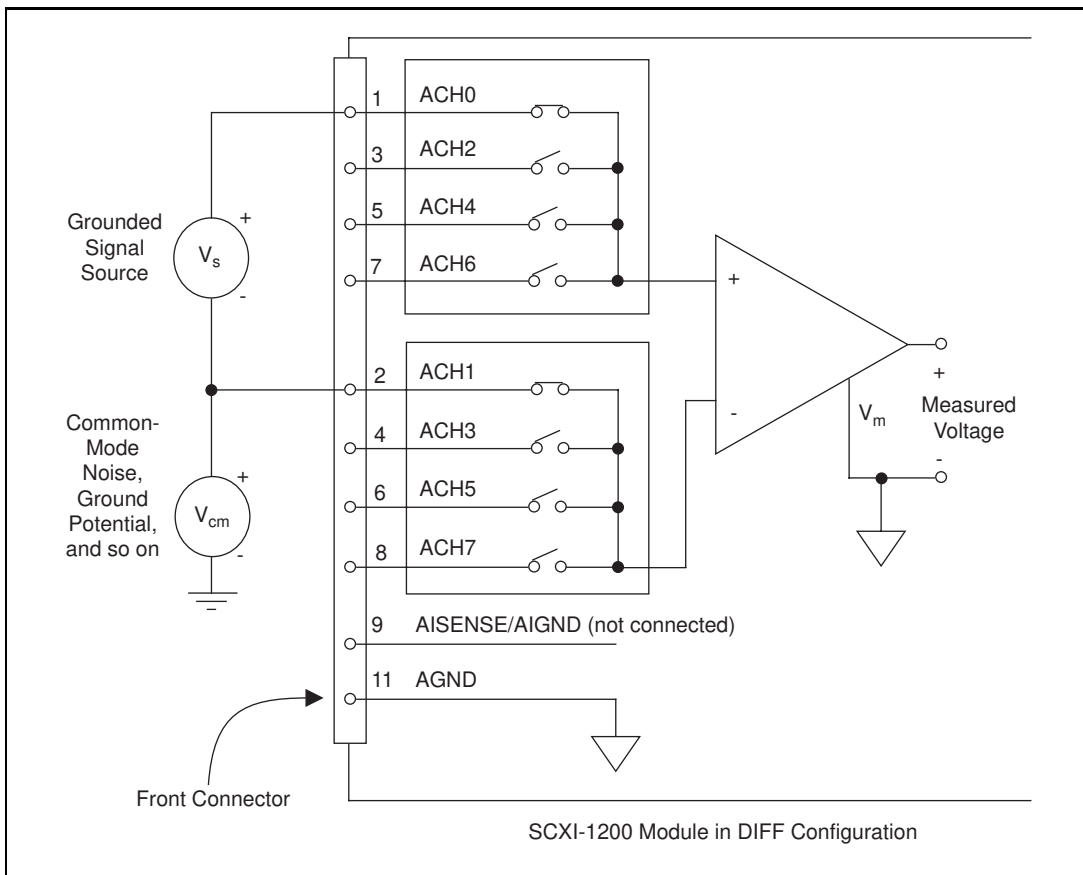

Figure 3-3. Differential Input Connections for Grounded Signal Sources

With this type of connection, the instrumentation amplifier rejects both the common-mode noise in the signal and the ground-potential difference between the signal source and the SCXI-1200 ground (shown as V_{CM} in Figure 3-3).

Differential Connections for Floating Signal Sources

Figure 3-4 shows how to connect a floating signal source to a SCXI-1200 module that is configured for DIFF input. Configuration instructions are included in the *Analog Input Configuration* section of Chapter 2, *Installation and Configuration*.

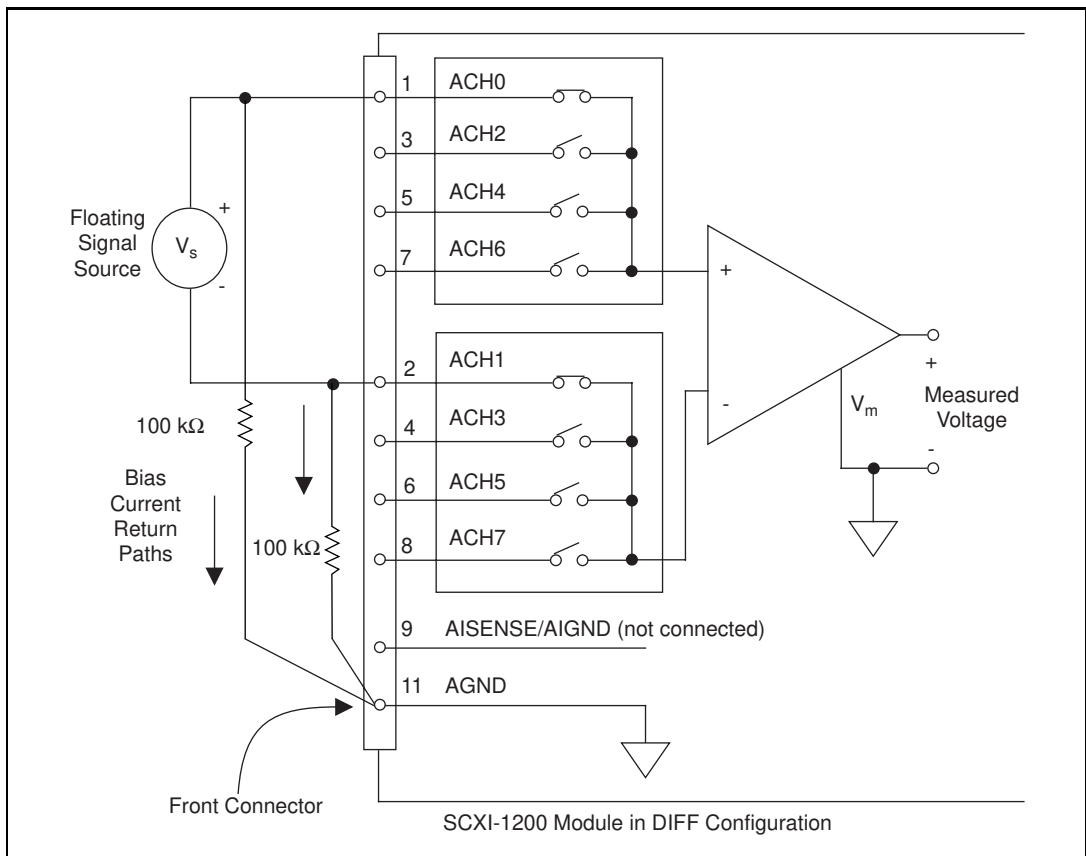

Figure 3-4. Differential Input Connections for Floating Sources

The 100 k Ω resistors shown in Figure 3-4 create a return path to ground for bias currents of the instrumentation amplifier. If there is no return path, the instrumentation amplifier bias currents charge stray capacitances, resulting in uncontrollable drift and possible saturation in the amplifier. Typically, values from 10 to 100 k Ω are used.

A resistor from each input to ground, as shown in Figure 3-4, provides bias current return paths for an AC-coupled input signal.

If the input signal is DC-coupled, you need only the resistor that connects the negative signal input to ground. This connection does not lower the input impedance of the analog input channel.

Single-Ended Connection Considerations

Single-ended connections are those in which all SCXI-1200 analog input signals are referenced to one common ground. The input signals are tied to the positive input of the instrumentation amplifier, and their common ground point is tied to the negative input of the instrumentation amplifier.

When the SCXI-1200 is configured for single-ended input (NRSE or RSE), eight analog input channels are available. You can use single-ended input connections when the following criteria are met by all input signals:

1. Input signals are high level (greater than 1 V).
2. Leads connecting the signals to the SCXI-1200 are less than 15 ft.
3. All input signals share a common reference signal (at the source).

If any of the preceding criteria are not met, using DIFF input configuration is recommended.

You can jumper configure the SCXI-1200 for two different types of single-ended connections, RSE configuration and NRSE configuration. Use the RSE configuration for floating signal sources; in this case, the SCXI-1200 provides the reference ground point for the external signal. Use the NRSE configuration for ground-referenced signal sources; in this case, the external signal supplies its own reference ground point and the SCXI-1200 should not supply one.

Single-Ended Connections for Floating Signal Sources (RSE Configuration)

Figure 3-5 shows how to connect a floating signal source to a SCXI-1200 module configured for single-ended input. You must configure the SCXI-1200 analog input circuitry for RSE input to make these types of connections. Configuration instructions are included in the *Analog Input Configuration* section of Chapter 2, *Installation and Configuration*.

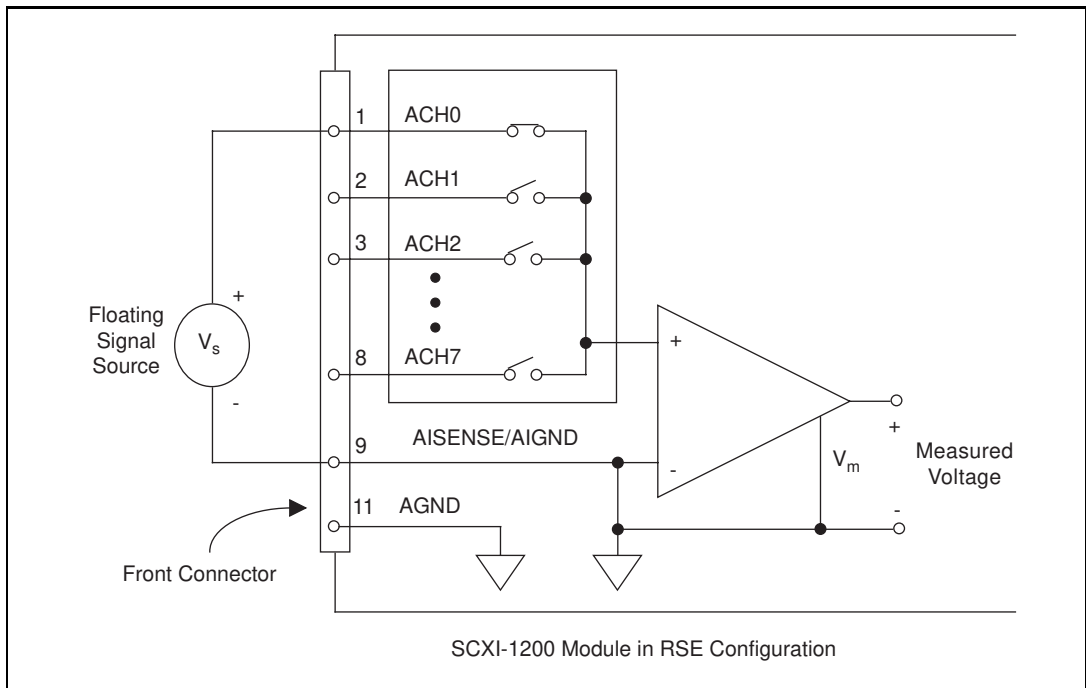

Figure 3-5. Single-Ended Input Connections for Floating Signal Sources

Single-Ended Connections for Grounded Signal Sources (NRSE Configuration)

If you measure a grounded signal source with a single-ended configuration, you must configure the SCXI-1200 in the NRSE input configuration. The signal is connected to the positive input of the SCXI-1200 instrumentation amplifier and the signal local ground reference is connected to the negative input of the SCXI-1200 instrumentation amplifier. Therefore, you must connect the ground

point of the signal to the AISENSE pin. Any potential difference between the SCXI-1200 ground and the signal ground appears as a common-mode signal at both the positive and negative inputs of the instrumentation amplifier and is therefore rejected by the amplifier. On the other hand, if the input circuitry of the SCXI-1200 is referenced to ground, such as in the RSE configuration, this difference in ground potentials appears as an error in the measured voltage.

Figure 3-6 shows how to connect a grounded signal source to a SCXI-1200 module configured in the NRSE configuration. Configuration instructions are included in the *Analog Input Configuration* section in Chapter 2, *Installation and Configuration*.

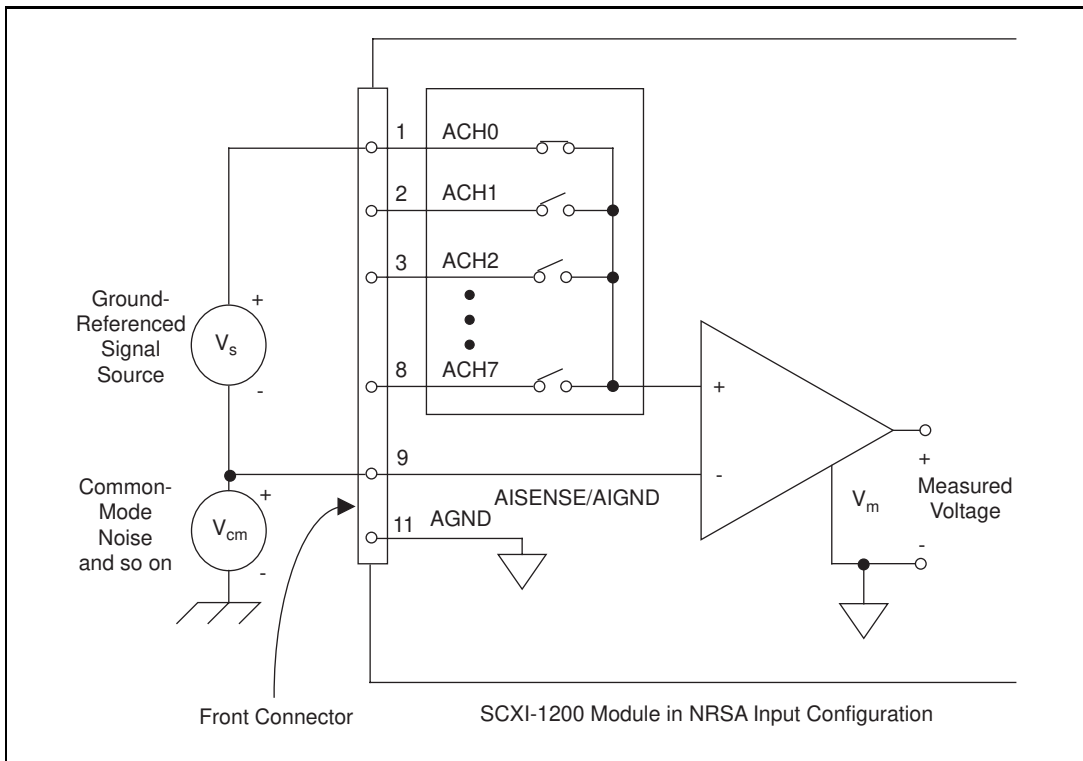

Figure 3-6. Single-Ended Input Connections for Grounded Signal Sources

Common-Mode Signal Rejection Considerations

Figures 3-3 and 3-6 show connections for signal sources that are already referenced to some ground point with respect to the SCXI-1200. In these cases, the instrumentation amplifier can reject any voltage caused by ground-potential differences between the signal source and the SCXI-1200. In addition, with differential input connections, the instrumentation amplifier can reject common-mode noise pickup in the leads connecting the signal sources to the SCXI-1200.

The common-mode input range of the SCXI-1200 instrumentation amplifier is the magnitude of the greatest common-mode signal that can be rejected.

The common-mode input range for the SCXI-1200 depends on the size of the differential input signal ($V_{diff} = V_{in}^+ - V_{in}^-$) and the gain setting of the instrumentation amplifier. In unipolar mode, the differential input range is 0 to 10 V. In bipolar mode, the differential input range is -5 to +5 V. Inputs should remain within a range of -5 to 10 V in both bipolar and unipolar modes.

Analog Output Signal Connections

Pins 10 through 12 of the front connector are analog output signal pins.

Pins 10 and 12 are the DAC0OUT and DAC1OUT signal pins. DAC0OUT is the voltage output signal for analog output channel 0. DAC1OUT is the voltage output signal for analog output channel 1.

Pin 11, AGND, is the ground-reference point for both analog output channels as well as analog input.

The following output ranges are available:

- Output signal range
 - Bipolar input ± 5 V*
 - Unipolar input 0 to 10 V*
- * Maximum load current ± 5 mA for 12-bit linearity.

Figure 3-7 shows how to make analog output signal connections.

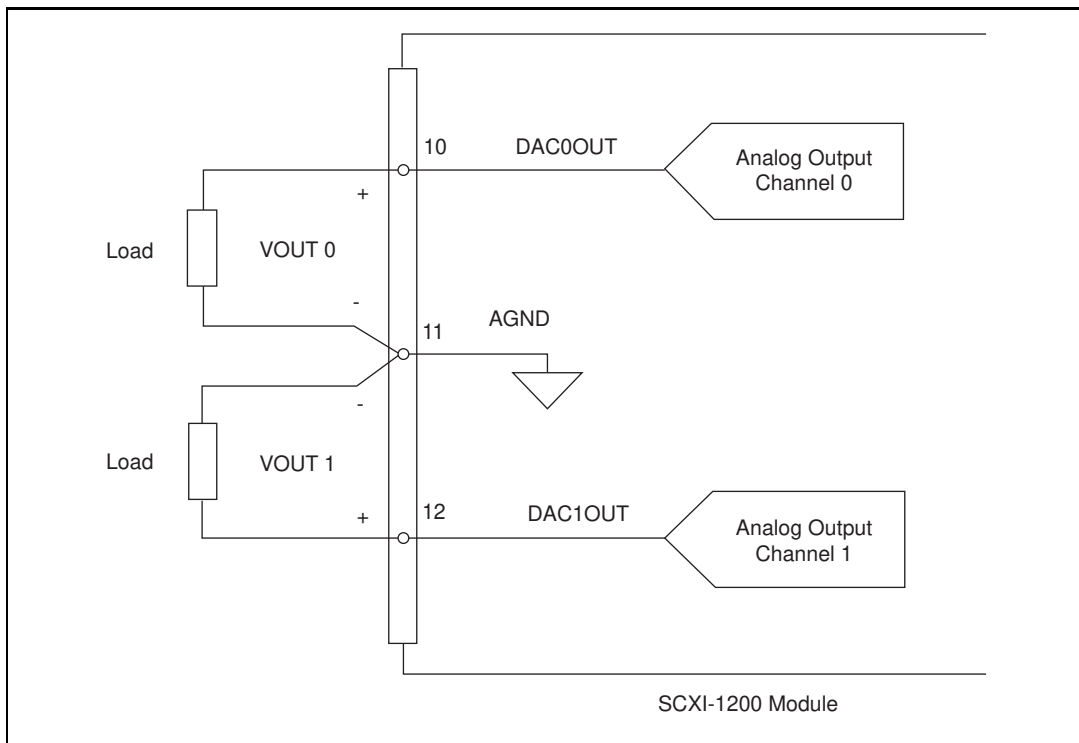

Figure 3-7. Analog Output Signal Connections

Digital I/O Signal Connections

Pins 13 through 37 of the front connector are digital I/O signal pins. Digital I/O on the SCXI-1200 uses the 82C55A integrated circuit. The 82C55A is a general-purpose peripheral interface containing 24 programmable I/O pins. These pins represent the three 8-bit ports (PA, PB, and PC) of the 8255A.

Pins 14 through 21 are connected to the digital lines PA<0..7> for digital I/O port A. Pins 22 through 29 are connected to the digital lines PB<0..7> for digital I/O port B. Pins 30 through 37 are connected to the digital lines PC<0..7> for digital I/O port C. Pin 13, DGND, is the digital ground pin for all three digital I/O ports.

The following specifications and ratings apply to the digital I/O lines.

- Absolute maximum voltage input rating
 - +5.5 V with respect to DGND
 - -0.5 V with respect to DGND
- Logical inputs and outputs
- Digital I/O lines

| | Min | Max |
|---|------------|--------------|
| – Input logic low voltage | 0 V | 0.8 V |
| – Input logic high voltage | 2.0 V | 5.25 V |
| • Output logic low voltage (at output current = 1.7 mA) | 0 V | 0.45 V |
| • Output logic high voltage (at output current = -200 μ A) | 2.4 V | 5.0 V |
| • Input load current ($0 < V_{in} < 5$ V) | -10.0 V | 10.0 μ A |
| • Darlington drive current ($R_{EXT} = 750$ Ω , $V_{EXT} = 1.5$ V) | -1.0 V | -4.0 mA |

Figure 3-8 illustrates signal connections for three typical digital I/O applications.

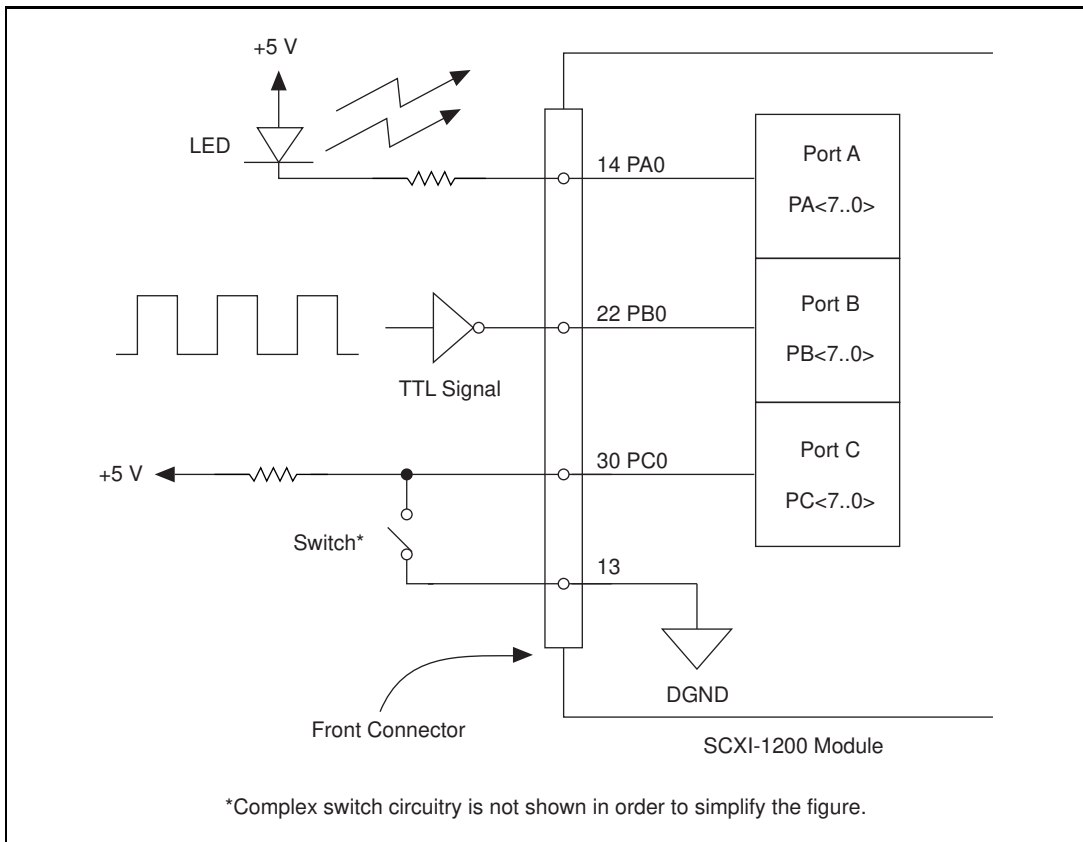

Figure 3-8. Digital I/O Connections

In Figure 3-8, port A is configured for digital output, and ports B and C are configured for digital input. Digital input applications include receiving TTL signals and sensing external device states such as the switch in Figure 3-8. Digital output applications include sending TTL signals and driving external devices such as the LED shown in Figure 3-8.

Port C Pin Connections

The signals assigned to port C depend on the mode in which the 82C55A is programmed. In mode 0, port C is considered to be two 4-bit I/O ports. In modes 1 and 2, port C is used for status and handshaking signals with two or three I/O bits mixed in. The following table summarizes the signal assignments of port C for each programmable mode. Refer to the *SCXI-1200 Register-Level Programmer Manual* for programming information.

Table 3-2. Port C Signal Assignments

| Programmable Mode | Group A | | | | | Group B | | |
|----------------------|--------------------|--------------------|------------------|--------------------|-------------------|--------------------|--------------------|-------------------|
| | PC7 | PC6 | PC5 | PC4 | PC3 | PC2 | PC1 | PC0 |
| Mode 0 | I/O | I/O | I/O | I/O | I/O | I/O | I/O | I/O |
| Mode 1 Input | I/O | I/O | IBF _A | STB _A * | INTR _A | STB _B * | IBFB _B | INTR _B |
| Mode 1 Output | OBF _A * | ACK _A * | I/O | I/O | INTR _A | ACK _B * | OBF _B * | INTR _B |
| Mode 2 | OBF _A * | ACK _A * | IBF _A | STB _A * | INTR _A | I/O | I/O | I/O |

*Indicates that the signal is active low.

Timing Specifications

Use the handshaking lines STB* and IBF to synchronize input transfers. Use the handshaking lines OBF* and ACK* to synchronize output transfers.

The following signals are used in the timing diagrams shown later in this chapter:

| Name | Type | Description |
|-------------|---------------|---|
| STB* | Input | Strobe Input—A low signal on this handshaking line loads data into the input latch. |
| IBF | Output | Input Buffer Full—A high signal on this handshaking line indicates that data has been loaded into the input latch. This is primarily an input acknowledge signal. |
| ACK* | Input | Acknowledge Input—A low signal on this handshaking line indicates that the data written from the specified port has been accepted. This signal is primarily a response from the external device that it has received the data from the SCXI-1200. |
| OBF* | Output | Output Buffer Full—A low signal on this handshaking line indicates that data has been written from the specified port. |
| INTR | Output | Interrupt Request—This signal becomes high when the 8255A is requesting service during a data transfer. Set the appropriate interrupt enable signals to generate this signal. |
| RD* | Internal | Read Signal—This signal is the read signal generated from the control lines of the PC I/O channel. |
| WR* | Internal | Write Signal—This signal is the write signal generated from the control lines of the PC I/O channel. |
| DATA | Bidirectional | Data Lines at the Specified Port—This signal indicates when the data on the data lines at a specified port is or should be available. |

Mode 1 Input Timing

The timing specifications for an input transfer in mode 1 are as follows:

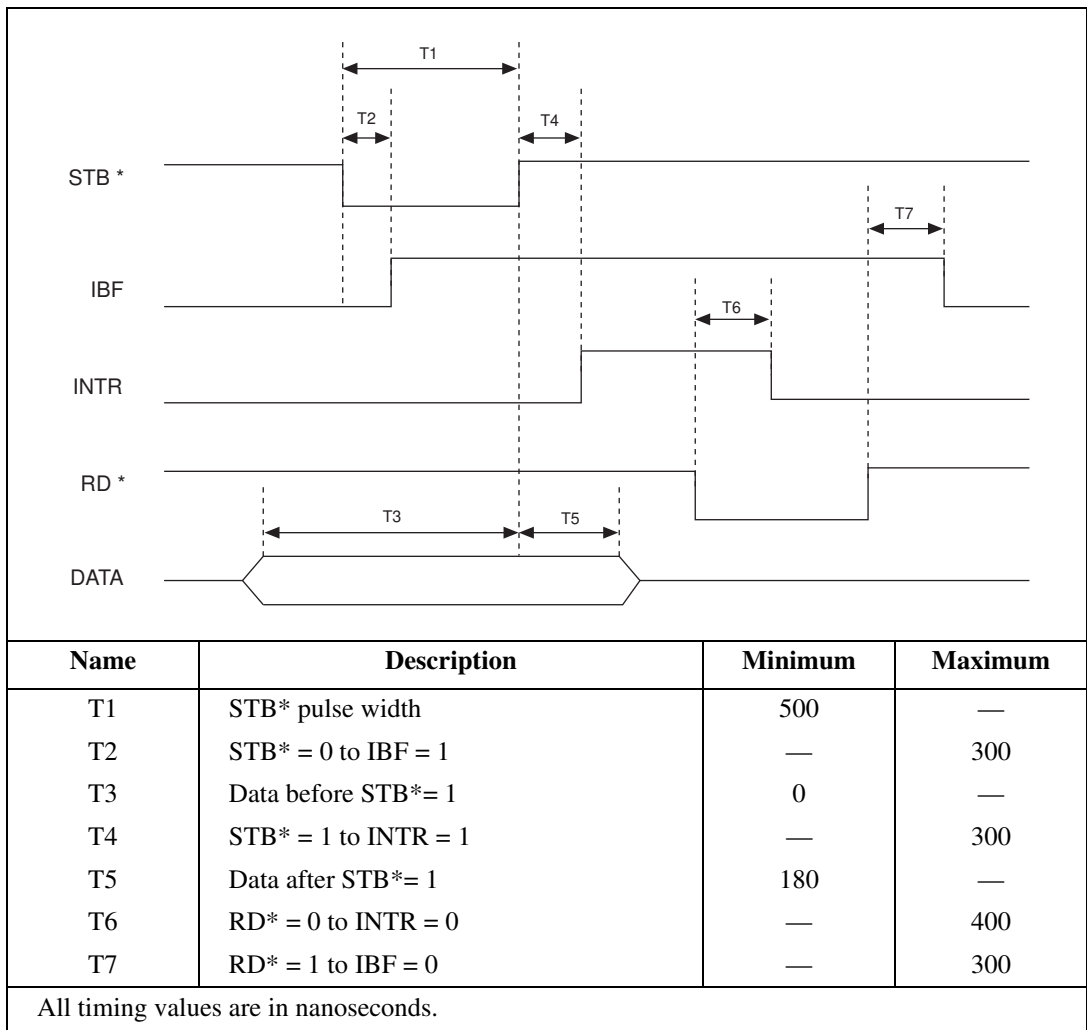

Figure 3-9. Mode 1 Timing Specifications for Input Transfers

Mode 1 Output Timing

The timing specifications for an output transfer in mode 1 are as follows:

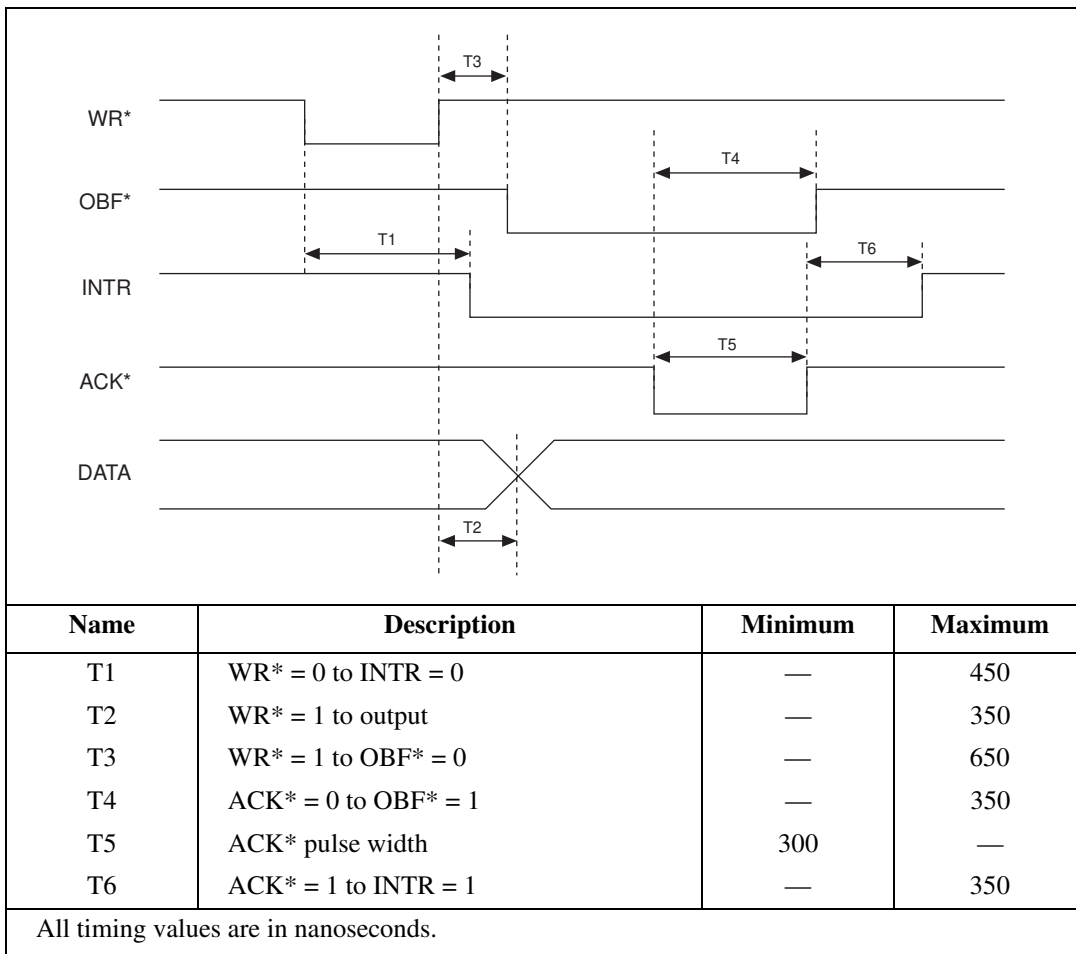

Figure 3-10. Mode 1 Timing Specifications for Output Transfers

Mode 2 Bidirectional Timing

The timing specifications for bidirectional transfers in mode 2 are as follows:

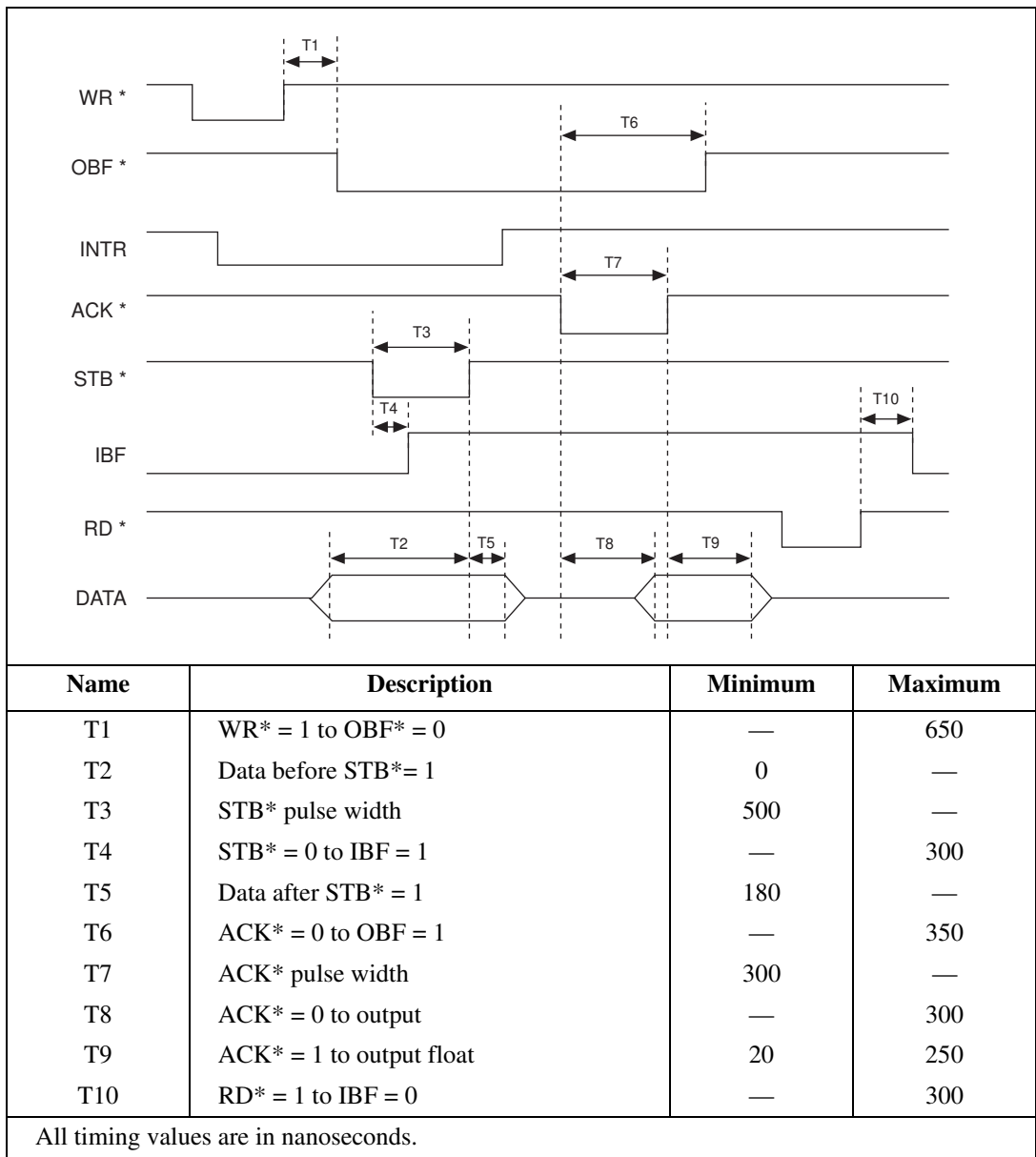

Figure 3-11. Mode 2 Timing Specification for Bidirectional Transfers

Timing Connections

Pins 38 through 48 of the front connector are connections for timing I/O signals. The SCXI-1200 timing I/O uses two 82C53 counter/timer integrated circuits. One circuit, designated 82C53(A), is used exclusively for DAQ timing, and the other, 82C53(B), is available for general use. Pins 38 through 40 carry external signals that you can use for DAQ timing in place of the dedicated 82C53(A). These signals are explained in the next section, *DAQ Timing Connections*. Pins 41 through 48 carry general-purpose timing signals from 82C53(B). These signals are explained in the *General-Purpose Timing Signal Connections and General-Purpose Counter/Timer Signals* section later in this chapter.

DAQ Timing Connections

Each 82C53 counter/timer circuit has three counters. Counter 0 on the 82C53(A) counter/timer (referred to as A0) is a sample interval counter in timed A/D conversions. Counter 1 on the 82C53(A) counter/timer (referred to as A1) is a sample counter that works in conjunction with counter 0 for data acquisition. These counters are not available for general use. In addition to counter A0, you can use EXTCONV* to externally time conversions. See the *SCXI-1200 Register-Level Programmer Manual* for the programming sequence you need to enable this input. Figure 3-12 shows the timing requirements for the EXTCONV* input. An A/D conversion is initiated by a falling edge on the EXTCONV*.

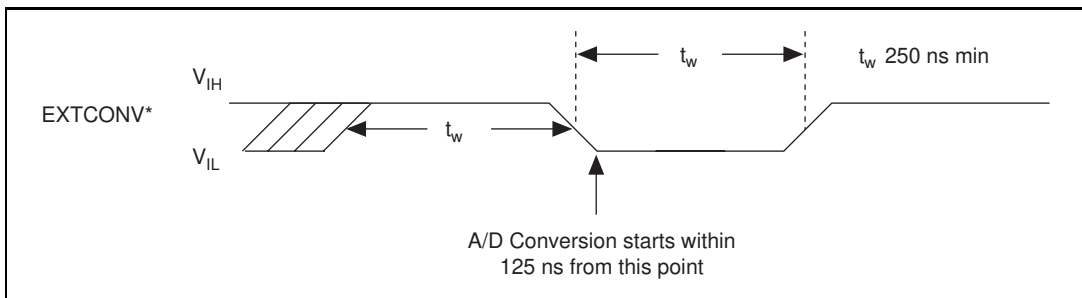

Figure 3-12. EXTCONV* Signal Timing

Another external control, EXTTRIG, can either start a DAQ sequence or terminate an ongoing DAQ sequence, depending on the mode—Hardware Trigger (HWTRIG) or Pretrigger (PRETRIG). These modes are software selectable.

In the HWTRIG mode, EXTTRIG serves as an external trigger to start a DAQ sequence. In this mode, posttrigger mode, the sample interval counter is gated off until a rising edge is sensed on the EXTTRIG line. External conversions, however, are enabled on the first rising edge of EXTCONV*, following the rising edge on the EXTTRIG line. Further transitions on the EXTTRIG line have no effect until a new DAQ sequence is established.

Figures 3-13 and 3-14 illustrate two possible posttrigger DAQ timing cases. In Figure 3-13, the rising edge on EXTTRIG is sensed when the EXTCONV* input is high. Thus, the first A/D conversion occurs on the second falling edge of EXTCONV*, after the rising edge on EXTTRIG. In Figure 3-14, the rising edge on EXTTRIG is sensed when the EXTCONV* input is low. In this case, the first A/D conversion occurs on the first falling edge of EXTCONV*, after the rising edge on EXTTRIG.

Notice that Figures 3-13 and 3-14 show a controlled acquisition mode DAQ sequence; that is, sample counter A1 disables further A/D conversions after the programmed count (3 in the examples shown in Figures 3-13 and 3-14) expires. The counter is not loaded with the programmed count until the first falling edge following a rising edge on the clock input; therefore two extra conversion pulses are generated as shown in Figures 3-13 and 3-14. You can also use EXTTRIG as an external trigger in free-run acquisition mode.

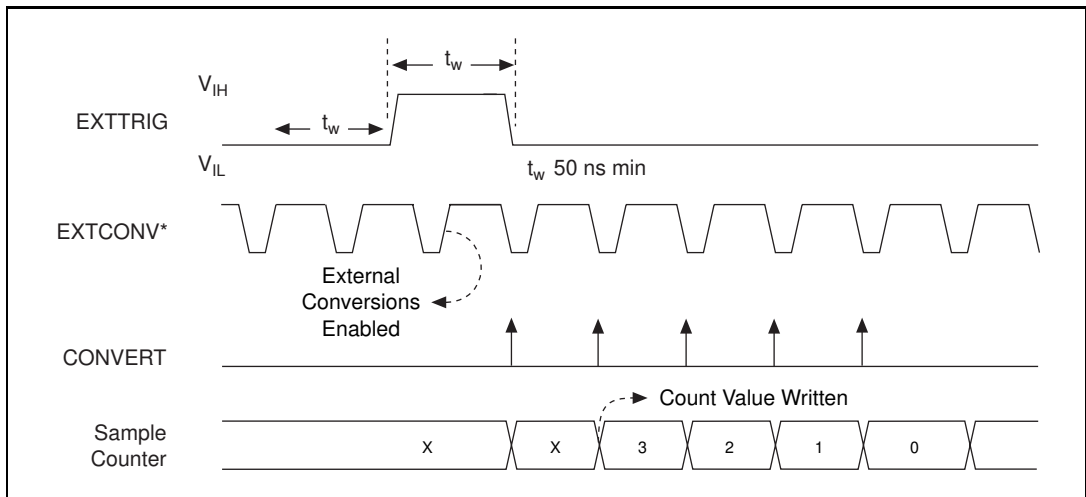

Figure 3-13. Posttrigger DAQ Timing Case 1

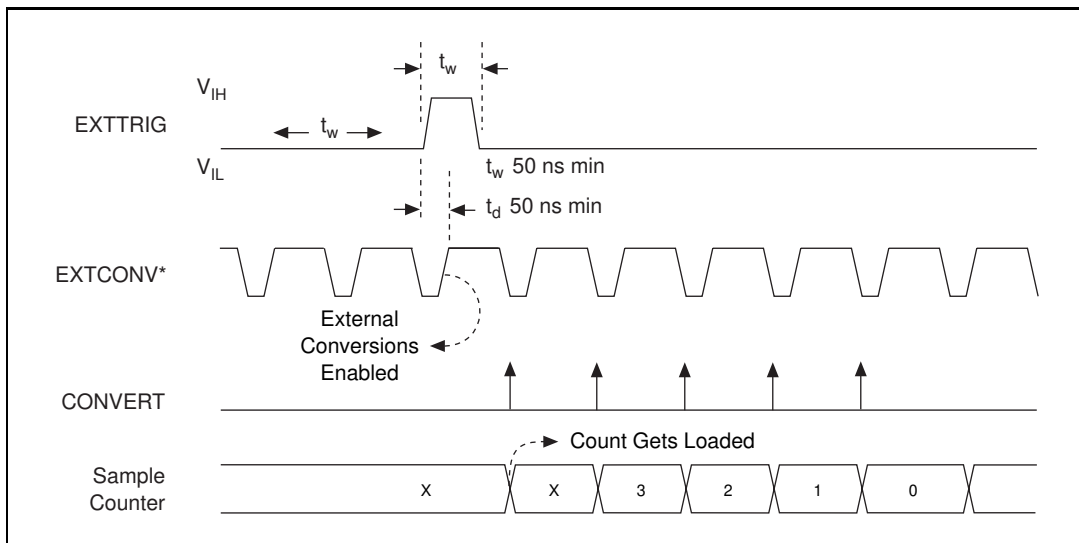

Figure 3-14. Posttrigger DAQ Timing Case 2

In the PRETRIG mode, EXTTRIG serves as a pretrigger signal. In pretrigger mode, A/D conversions are enabled via software before a rising edge is sensed on the EXTTRIG input. However, the sample counter, counter A1, is not gated on until a rising edge is sensed on the EXTTRIG input. Additional transitions on this line have no effect until you initiate a new DAQ sequence. Conversions remain enabled for the programmed count after the trigger; therefore, data can be acquired before and after the trigger. Pretrigger mode works only in controlled acquisition mode, that is, counter A1 is required to disable A/D conversions after the programmed count expires. Thus, the maximum number of samples acquired after the trigger is limited to 65,535. The number of samples acquired before the trigger is limited only by the size of the memory buffer available for data acquisition. Figure 3-15 shows a pretrigger DAQ timing sequence. Notice that, because A1 is loaded and armed, it allows exactly four pulses after the EXTTRIG pulses.

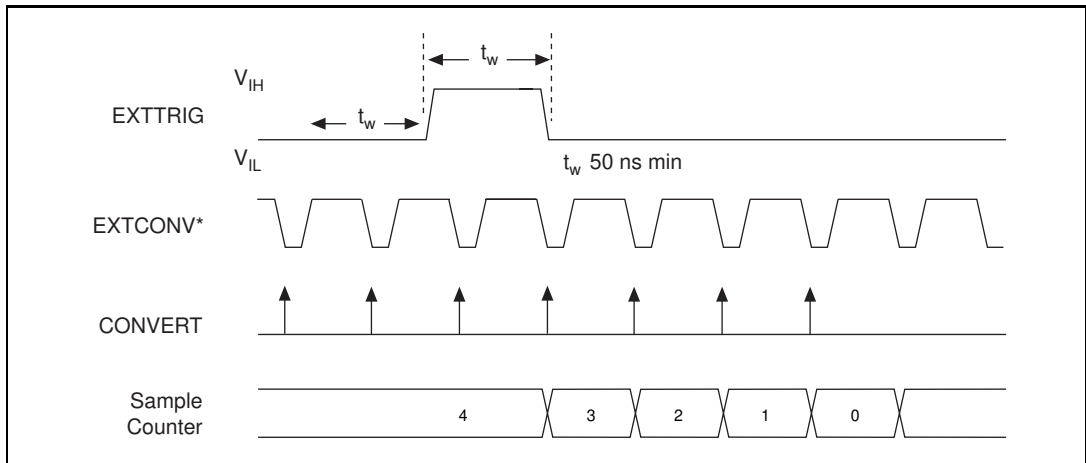

Figure 3-15. Pretrigger DAQ Timing

Because both pretrigger and posttrigger modes use EXTTRIG input, you can only use one mode at a time.

You can use the OUTB1 pin to initiate timing intervals in the interval acquisition modes. This is explained in detail in the *Timing I/O Circuitry* section in Chapter 4, *Theory of Operation*.

You use the final external control signal, EXTUPDATE*, to externally control updating the output voltage of the 12-bit DACs or to generate an externally timed interrupt. There are two update modes, immediate update and later update. In immediate update mode the analog output is updated as soon as the value is written into the DAC. If you select the later update mode, the corresponding DAC voltage is updated by a low level on the EXTUPDATE* signal. Furthermore, if you enable interrupt generation, an interrupt is generated whenever a rising edge is detected on the EXTUPDATE* bit. Therefore, you can perform externally timed, interrupt-driven waveform generation on the SCXI-1200.

Figure 3-16 illustrates a waveform generation timing sequence using the EXTUPDATE* signal. Notice that the DACs are updated by a *low level* on the EXTUPDATE* line. Any writes to the DAC data registers while EXTUPDATE* is low therefore result in immediate update of the DAC output voltages.

In the following figures, DAC OUTPUT UPDATE is the pulse that updates the analog output, CNTINT is the signal that interrupts the PC, DACWRT is the signal that writes a new value to the DAC and TMRINTCLR is the signal that clears the interrupt.

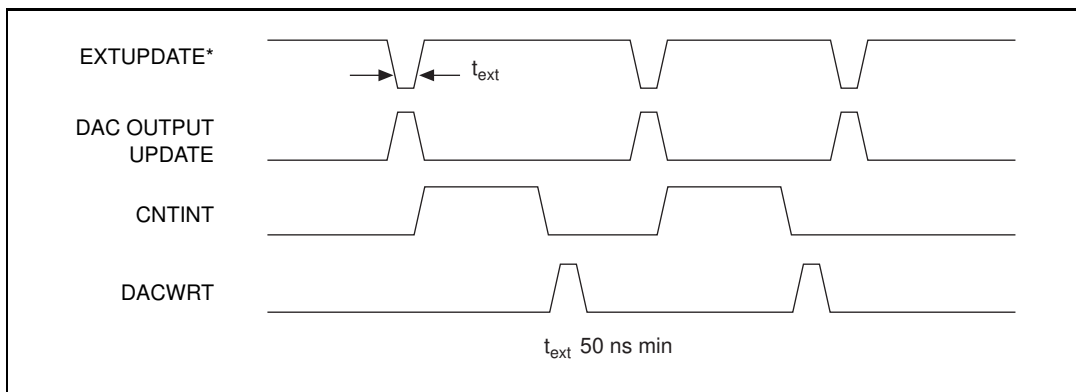

Figure 3-16. EXTUPDATE* Signal Timing for Updating DAC Output

The following rating applies to the EXTCONV*, EXTTRIG and EXTUPDATE* signals.

- Absolute maximum voltage input rating -0.5 to 7.0 V with respect to DGND

General-Purpose Timing Signal Connections and General-Purpose Counter/Timer Signals

The general-purpose timing signals include the GATE, CLK, and OUT signals for the three 82C53(B) counters. The 82C53 counter/timers can be used for general-purpose applications such as pulse and square wave generation; event counting; and pulse-width, time-lapse, and frequency measurement. For these applications, CLK and GATE signals are sent to the counters, and the counters are programmed for various operations. The single exception is counter B0, which has an internal 2 MHz clock.

You perform pulse and square wave generation by programming a counter to generate a timing signal at its OUT output pin.

You perform event counting by programming a counter to count rising or falling edges applied to any of the 82C53 CLK inputs. You can then read the counter value to determine the number of edges that have occurred. You can gate counter operation on and off during event

counting. Figure 3-17 shows connections for a typical event-counting operation in which a switch is used to gate the counter on and off.

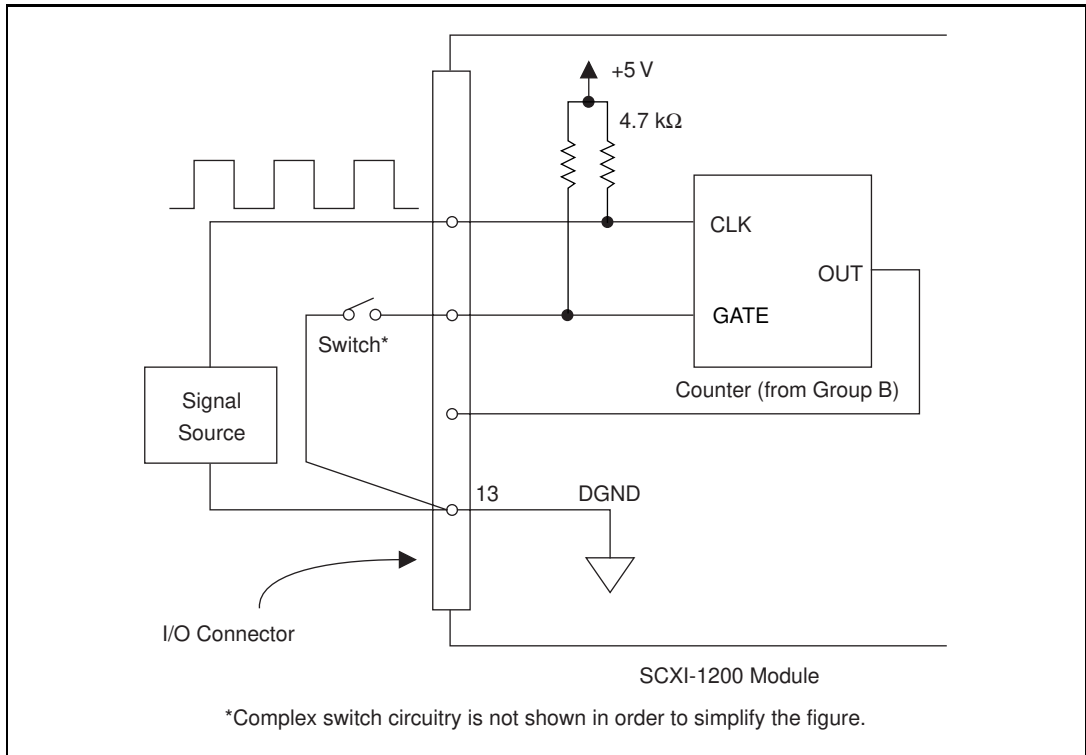

Figure 3-17. Event-Counting Application with External Switch Gating

Pulse-width measurement is performed by level gating. The pulse you want to measure is applied to the counter GATE input. The counter is loaded with the known count and is programmed to count down while the signal at the GATE input is high. The pulse width equals the counter difference (loaded value minus read value) multiplied by the CLK period.

Perform time-lapse measurement by programming a counter to be edge gated. An edge is applied to the counter GATE input to start the counter. You can program the counter to start counting after receiving a low-to-high edge. The time lapse since receiving the edge equals the counter value difference (loaded value minus read value) multiplied by the CLK period.

To perform frequency measurement, program a counter to be level gated and count the number of falling edges in a signal applied to a CLK input. The gate signal applied to the counter GATE input is of known duration. In this case, you program the counter to count falling edges at the CLK input while the gate is applied. The frequency of the input signal then equals the count value divided by the gate period.

Figure 3-18 shows the connections for a frequency measurement application. You can also use a second counter to generate the gate signal in this application. In this case, program the second counter for a one-shot mode. This scheme needs an external inverter to make the output pulse of the second counter active high.

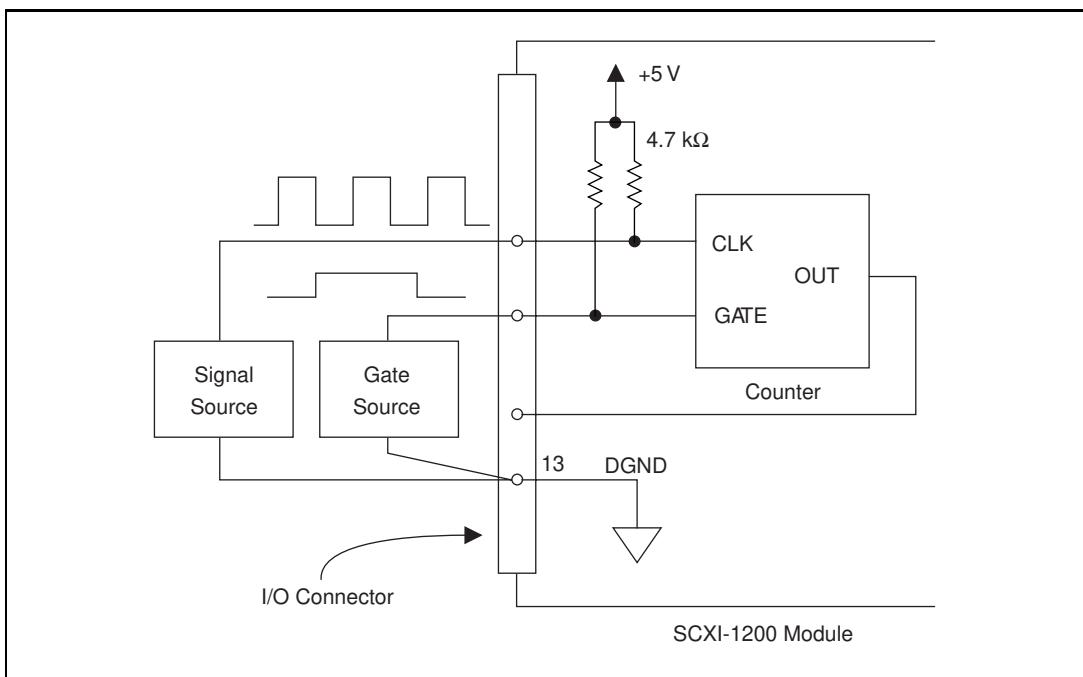

Figure 3-18. Frequency Measurement Application

The GATE, CLK, and OUT signals for counters B1 and B2 are available at the I/O front connector. In addition, the GATE and CLK pins are pulled up to +5 V through a 4.7 kΩ resistor.

The following specifications and ratings apply to the 82C53 I/O signals:

- Absolute maximum voltage input rating -0.5 to 7.0 V with respect to DGND

- 82C53 digital input specifications (referenced to DGND):
 - V_{IH} input logic high voltage 2.2 V minimum
 - V_{IL} input logic low voltage 0.8 V maximum
 - Input load current $\pm 10.0 \mu\text{A}$ maximum
- 82C53 digital output specifications (referenced to DGND):
 - V_{OH} output logic high voltage 2.4 V minimum
 - V_{OL} output logic low voltage 0.45 V maximum
 - I_{OH} output source current, at V_{OH} 400.0 μA maximum
 - I_{OL} output sink current, at V_{OL} 2.2 mA maximum

Figure 3-19 shows the timing requirements for the GATE and CLK input signals and the timing specifications for the OUT output signals of the 82C53.

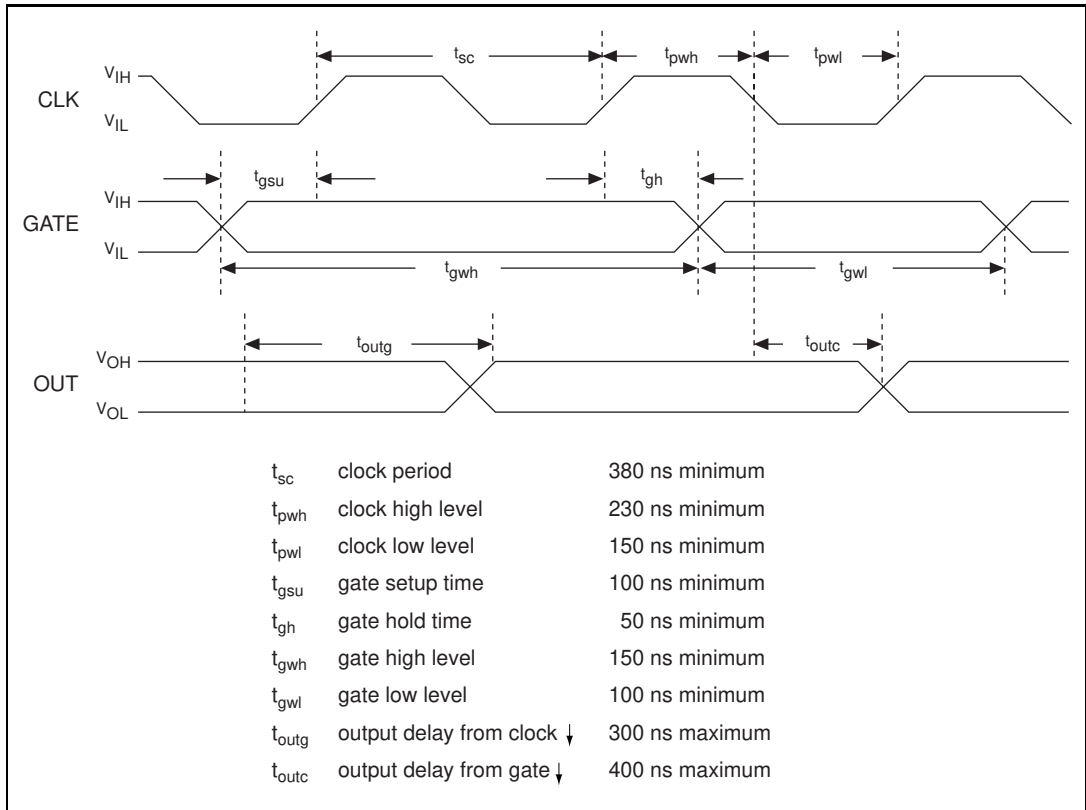

Figure 3-19. General-Purpose Timing Signals

The GATE and OUT signals in Figure 3-19 are referenced to the rising edge of the CLK signal.

Digital I/O Signal Connections for the SCXibus

When used with other SCXI modules, the SCXI-1200 communicates with the SCXibus by using some digital I/O lines. Four lines from port B are used as outputs and one line of port C is used as input for SCXibus communication.

Pins 26 through 29, 31, 40, and 43 constitute the front signal connector digital I/O lines that are used with the SCXibus—the digital output signals, the digital input signals, and the digital timing signals.

The digital input signal for SCXI is pin 31, SERDATIN, which is equivalent to the SCXibus signal MOSI.

The digital output signals for SCXI are pins 26, 27, 28, and 29. The SCXI-1200 uses these pins to configure the SCXI module. Each digital line emulates the SCXibus communication signals as follows:

- Pin 26, SERDATOUT, is equivalent to the SCXibus MISO serial data input line.
- Pin 27, DAQD*/A, is equivalent to the SCXibus D*/A line, and indicates to the module whether the incoming serial stream on SERDATIN is data (DAQD*/A = 0) or address (DAQD*/A = 1) information.
- Pin 28, SLOT0SEL*, is equivalent to the SCXibus INTR* line, and indicates whether the data on the SERDATIN line is being sent to Slot 0 (SLOT0SEL* = 0) or to a module (SLOT0SEL* = 1).
- Pin 29, SERCLK, is equivalent to the SCXibus SPICLK line.

The digital timing signals (SCANCLK and HOLDTRIG) for SCXI are sent out on pins 40 and 43.

- Pin 40, SCANCLK, is equivalent to the SCXibus TRIG0 line.
- Pin 43, HOLDTRIG, is equivalent to the SCXibus TRIG1 line.

If you use the SCXI-1200 for configuring the modules or Slot 0 of the chassis in which it resides, then these signals are internally routed to the SCXibus. The signal that is driven by the SCXibus (categorized as input, above), as well as those driven by the DIO circuitry onto the SCXibus (categorized as outputs, above), appear on the corresponding DIO pin on the connector.

If the SCXI-1200 programs another chassis through its 50-pin front connector, then these DIO signals tap into the SCXIBus of the second chassis. You must use an SCXI-1341, SCXI-1342, or SCXI-1344 cable assembly for this purpose.

Theory of Operation

This chapter contains a functional overview of the SCXI-1200 module and explains the operation of each functional unit of the SCXI-1200.

Functional Overview

The block diagram in Figure 4-1 shows a functional overview of the SCXI-1200 board.

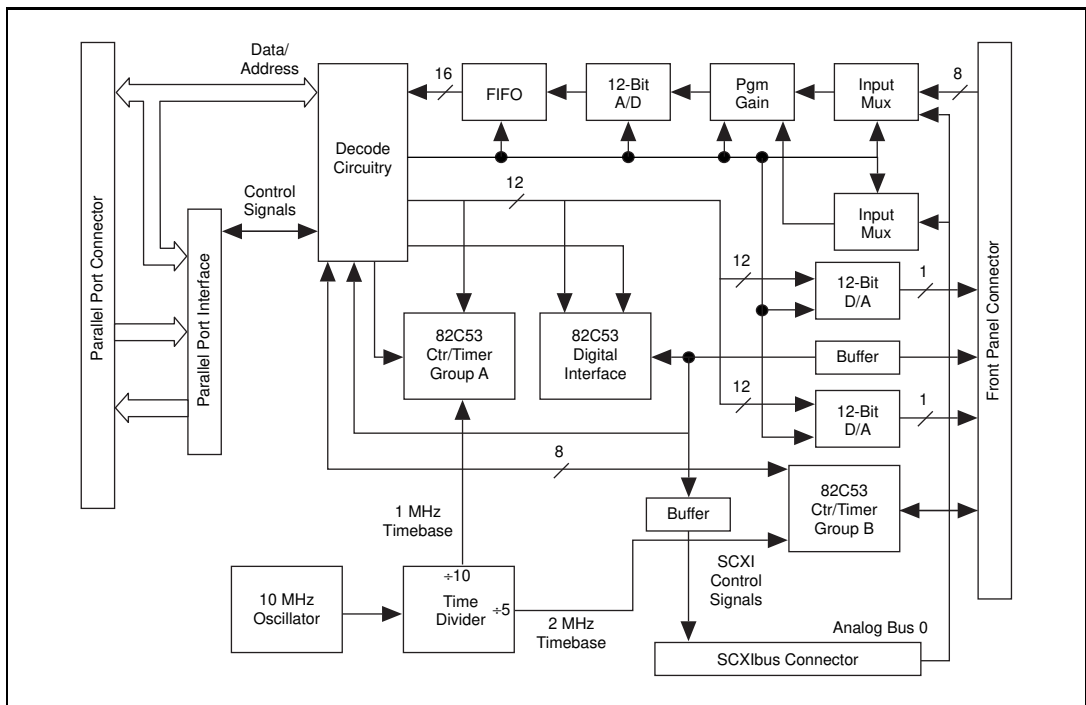

Figure 4-1. SCXI-1200 Block Diagram

The major components of the SCXI-1200 are as follows:

- SCXIbus connector
- Parallel port A connector

- Analog input and DAQ circuitry
- Analog output circuitry
- Digital I/O and interface circuitry
- Timing I/O circuitry
- SCXI digital interface

You can execute DAQ functions by using the analog input circuitry and some of the timing I/O circuitry. The internal data and control buses interconnect the components.

The rest of the chapter explains the theory of operation of each of the SCXI-1200 components. The theory of operation for the DAQ circuitry is in the discussion of the analog input circuitry.

Analog Input and DAQ Circuitry

The SCXI-1200 has eight channels of analog input with software-programmable gain and 12-bit A/D conversion. Using the timing circuitry, the SCXI-1200 can also automatically time multiple A/D conversions. Figure 4-2 shows a block diagram of the analog input and DAQ circuitry.

In the following section, “stand-alone mode”, “parallel mode”, and “single-module parallel scanning” are used interchangeably to indicate a Lab-PC+ mode, in which there is no Slot 0 or multiple-module multiplexed acquisition. The SCXI-1200 samples its input channels and not Analog Bus 0 at all times.

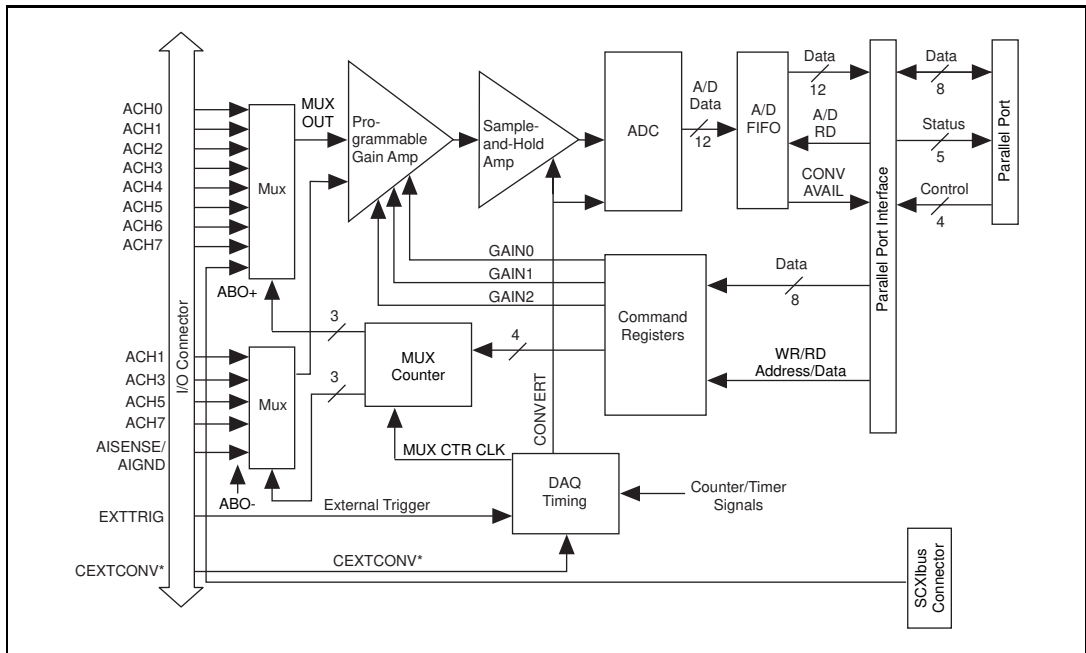

Figure 4-2. Analog Input and DAQ Circuitry Block Diagram

You can operate the SCXI-1200 as a stand-alone module, in which it samples its own input channels, or you can use the SCXI-1200 in conjunction with other SCXI modules, in which case it samples Analog Bus 0.

The stand-alone configuration is explained next. The latter configuration, called SCXI mode, is explained in the *SCXI Scanning Modes* section later in this chapter.

Analog Input Circuitry

The analog input circuitry consists of two analog input multiplexers, a software-programmable gain amplifier, a 12-bit ADC, and a 12-bit FIFO memory that is sign-extended to 16 bits.

One of the input multiplexers has eight analog input channels (channels 0 through 7). The other multiplexer is connected to channels 1, 3, 5, and 7 for differential mode. The input multiplexers provide input overvoltage protection of ± 45 V, powered on or off. In addition, you can select the SCXI Analog Bus 0 as the input channel. Use software

configuration to accomplish this whenever the SCXI-1200 is in the SCXI mode and you have selected another module for signal conditioning.

The programmable gain amplifier applies gain to the input signal, allowing an input analog signal to be amplified before being sampled and converted, thus increasing measurement resolution and accuracy. The gain of the instrumentation amplifier is software selectable. The SCXI-1200 board provides gains of 1, 2, 5, 10, 20, 50, and 100.

The SCXI-1200 uses a 12-bit successive-approximation ADC. The 12-bit resolution of the converter allows the converter to resolve its input range into 4,096 different steps. This resolution also provides a 12-bit digital word that represents the value of the input voltage level with respect to the converter input range. The ADC has an input range of ± 5 V and 0 to 10 V.

When an A/D conversion is complete, the ADC clocks the result into the A/D FIFO. The A/D FIFO is 16 bits wide and 2 kwords deep. This FIFO serves as a buffer to the ADC and provides two benefits. First, when an A/D conversion is complete, the value is saved in the A/D FIFO for later reading, and the ADC can start a new conversion. Secondly, the A/D FIFO can collect up to 2 k A/D conversion values before any information is lost, thus allowing software some extra time to catch up with the hardware. If you store more than 2 k values in the A/D FIFO without reading from the A/D FIFO, an error condition called A/D FIFO overflow occurs and you lose A/D conversion information.

The output from the ADC can be interpreted as either straight binary or two's complement, depending on which input mode you select (unipolar or bipolar). In unipolar mode, the data from the ADC is interpreted as a 12-bit straight binary number with a range of 0 to +4,095. In bipolar mode, the data from the ADC is interpreted as a 12-bit two's complement number with a range of -2,048 to +2,047. In this mode, the MSB of the ADC result is inverted to make it two's complement. The output from the ADC is then sign-extended to 16 bits, causing either a leading 0 or a leading F (hex) to be added, depending on the coding and the sign. Thus, data values read from the FIFO are 16 bits wide.

DAQ Timing Circuitry

A DAQ operation refers to the process of taking a sequence of A/D conversions with the sample interval (the time between successive A/D conversions) carefully timed. The DAQ timing circuitry consists of

various clocks and timing signals that perform this timing. The SCXI-1200 board can perform both single-channel data acquisition and multiple-channel (scanned) data acquisition in two modes—continuous and interval. The SCXI-1200 uses a counter to switch between analog input channels automatically during scanned data acquisition.

DAQ timing consists of signals that initiate a DAQ operation, initiate individual A/D conversions, gate the DAQ operation, and generate scanning clocks. Sources for these signals are supplied mainly by timers on the SCXI-1200 board. One of the two 82C53 integrated circuits is reserved for this purpose.

You can acquire data on a single channel or on multiple channels. In either case, you can perform continuous or interval acquisition.

Single-Channel Data Acquisition

During single-channel data acquisition, the channel select and gain bits in Command Register 1 select the gain and analog input channel before data acquisition is initiated. These gain and multiplexer settings remain constant during the entire DAQ process; therefore, you read all A/D conversion data from a single channel. In addition, you can select the SCXI Analog Bus 0 for data acquisition. This happens whenever another module is selected and that module outputs its signal onto AB0.

In single-channel continuous acquisition mode, the SCXI-1200 samples a single channel continuously without delays.

In single-channel interval acquisition mode, the SCXI-1200 samples a single channel a programmable number of times, waits for the duration of the scan interval, and repeats this cycle.

Multiple-Channel (Scanned) Data Acquisition

Multiple-channel data acquisition is performed by enabling scanning during data acquisition. Multiple-channel scanning is controlled by a scan counter.

For scanning operations, the scan counter decrements from the highest numbered channel, which you specify, through channel 0, and then repeats the sequence. Thus, you can scan any number of channels from two to eight. Notice that you use the same gain setting for all channels in the scan sequence.

In scanned continuous acquisition mode, the SCXI-1200 scans the selected channels repeatedly without delays and samples them.

In scanned-interval acquisition mode, the SCXI-1200 scans the selected channels, waits for the duration of the scan interval, and repeats the cycle.

DAQ Rates

Maximum DAQ rates (number of samples per second) are determined by the conversion period of the ADC plus the sample-and-hold acquisition time as well as any extra time required to transfer data back to the PC. During multiple-channel scanning, the DAQ rates are further limited by the settling time of the input multiplexers and programmable gain amplifier. After the input multiplexers are switched, the amplifier must be allowed to settle to the new input signal value to within 12-bit accuracy before you perform an A/D conversion, or else 12-bit accuracy will not be achieved. The settling time is a function of the gain selected.



Note: *If you are using Remote SCXI, the serial baud rate will affect the maximum achievable DAQ rate. For more information, see Appendix A, Specifications, in the SCXI Chassis User Manual.*

The SCXI-1200 DAQ timing circuitry detects when DAQ rates are high enough to cause A/D conversions to be lost. This happens if the sampling interval is shorter than the conversion time for the ADC. If this is the case, this circuitry sets an overrun error flag. If the recommended DAQ rates in Table 4-2 are exceeded (an error flag is *not* automatically set), the analog input circuitry may not perform at 12-bit accuracy. If these rates are exceeded by more than a few microseconds, A/D conversions may be lost. Table 4-1 shows the recommended multiplexer and gain settling times for different gain settings. Table 4-2 shows the maximum recommended DAQ rates for both single-channel and multiple-channel data acquisition. Notice that for a single-channel data acquisition, the data can be acquired at the maximum rate at any gain setting. This assumes that the input signal is band-limited. The analog input bandwidth, however, is lower for higher gains. For multiple-channel data acquisition, observing the DAQ rates in Table 4-2 ensures 12-bit accuracy.

For short bursts of less than 2 ksamples, you can obtain a higher rate of 120 kS/s. This rate is limited only by the ADC conversion time, which is specified at 8.33 μ s.

Table 4-1. Analog Input Settling Time Versus Gain

| Gain Setting | Settling Time Recommended |
|---------------------|---------------------------------------|
| 1, 2, 5, 10, 20, 50 | 18 μ s typ, 25 μ s guaranteed |
| 100 | 40 μ s |

Table 4-2. SCXI-1200 Maximum Recommended DAQ Rates

| Acquisition Mode | Gain Setting | Rate | |
|------------------|--------------------------|-----------|-----------------|
| | | EPP Mode | Centronics Mode |
| Single channel | 1, 2, 5, 10, 20, 50, 100 | 100 kS/s | 25 kS/s |
| Multiple channel | 1, 2, 5, 10, 20, 50 | 55.5 kS/s | 25 kS/s |
| | 100 | 25 kS/s | 25 kS/s |

The recommended DAQ rates in Table 4-2 assume that voltage levels on all the channels included in the scan sequence are within range for the given gain and are driven by low-impedance sources. The signal ranges for the possible gains are shown in Tables 4-3 and 4-4. Signal levels outside the ranges shown in Table 4-3 on the channels included in the scan sequence adversely affect the input settling time. Similarly, you may need greater settling time for channels driven by high-impedance signal sources.

Table 4-3. Bipolar Analog Input Signal Range Versus Gain

| Gain Setting | Input Signal Range |
|--------------|-----------------------|
| 1 | -5 V to 4.99756 V |
| 2 | -2.5 V to 2.49878 V |
| 5 | -1.0 V to 0.99951 V |
| 10 | -500 mV to 499.756 mV |
| 20 | -250 mV to 249.877 mV |

Table 4-3. Bipolar Analog Input Signal Range Versus Gain (Continued)

| Gain Setting | Input Signal Range |
|---------------------|---------------------------|
| 50 | -250 mV to 249.877 mV |
| 100 | -50 mV to 49.975 mV |

Table 4-4. Unipolar Analog Input Signal Range Versus Gain

| Gain Setting | Input Signal Range |
|---------------------|---------------------------|
| 1 | 0 V to 9.99756 V |
| 2 | 0 V to 4.99878 V |
| 5 | 0 V to 1.99951 V |
| 10 | 0 mV to 999.756 mV |
| 20 | 0 mV to 499.877 mV |
| 50 | 0 mV to 199.951 mV |
| 100 | 0 mV to 99.975 mV |

Analog Output Circuitry

The SCXI-1200 has two channels of 12-bit D/A output. Each analog output channel can provide unipolar or bipolar output. Figure 4-3 shows a block diagram of the analog output circuitry.

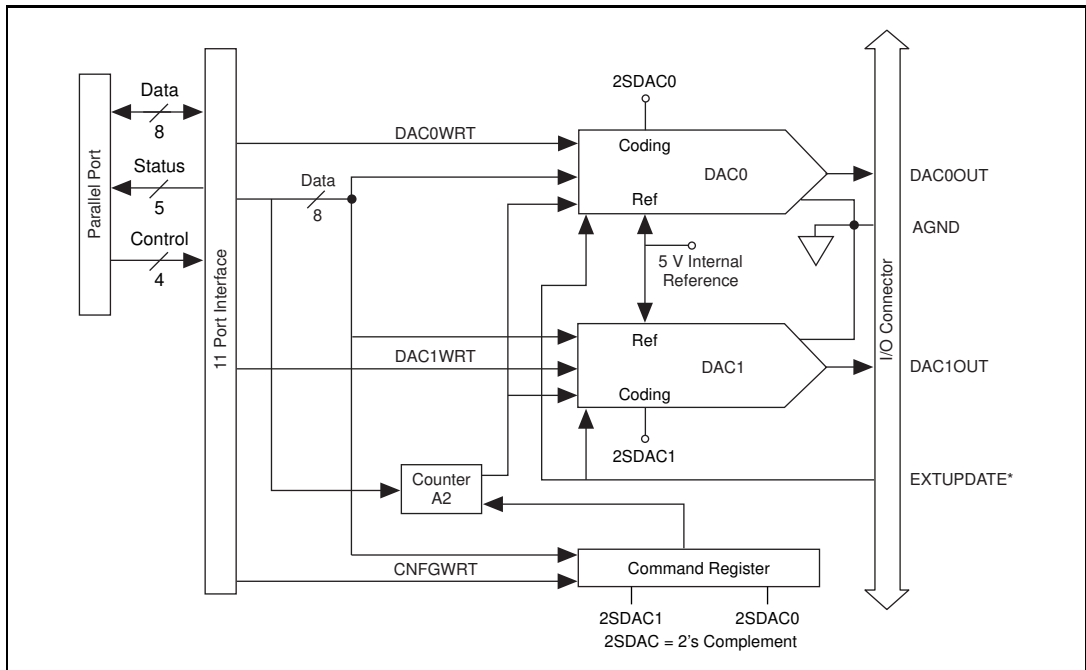

Figure 4-3. Analog Output Circuitry Block Diagram

Each analog output channel contains a 12-bit DAC. The DAC in each analog output channel generates a voltage proportional to the input V_{ref} multiplied by the digital code loaded into the DAC. You can load each DAC with a 12-bit digital code by writing to the DAC0 (L and H) and DAC1 (L and H) Registers on the SCXI-1200. The voltage output from the two DACs is available at the SCXI-1200 I/O connector DAC0OUT and DAC1OUT pins.

There are two ways you can upgrade the DAC voltages. In the first mode, the DAC output voltage is updated as soon as you write to the corresponding DAC Data Register. In the second mode, the DAC output voltage does not change until a falling edge is detected either from counter A2 or from EXTUPDATE*. These two modes are software selectable.

You can program each DAC channel for either a unipolar voltage output or a bipolar voltage output range. A unipolar output gives an output voltage range of 0.0000 to +9.9976 V. A bipolar output gives an output voltage range of -5.0000 to +4.9976 V. For unipolar output, 0.0000 V

output corresponds to a digital code word of 0. For bipolar output, -5.0000 V output corresponds to a digital code word of F800 hex.

One LSB is the voltage increment corresponding to a LSB change in the digital code word. For both outputs, one LSB corresponds to:

$$1 \text{ LSB} = \frac{10V}{4,096}$$

Digital I/O Circuitry

The digital I/O circuitry has an 82C55A integrated circuit. The 82C55A is a general-purpose PPI containing 24 programmable I/O pins. These pins represent the three 8-bit I/O ports (A, B, and C) of the 82C55A, as well as PA<0..7>, PB<0..7>, and PC<0..7> on the SCXI-1200 I/O connector. Figure 4-4 shows a block diagram of the digital I/O circuitry.

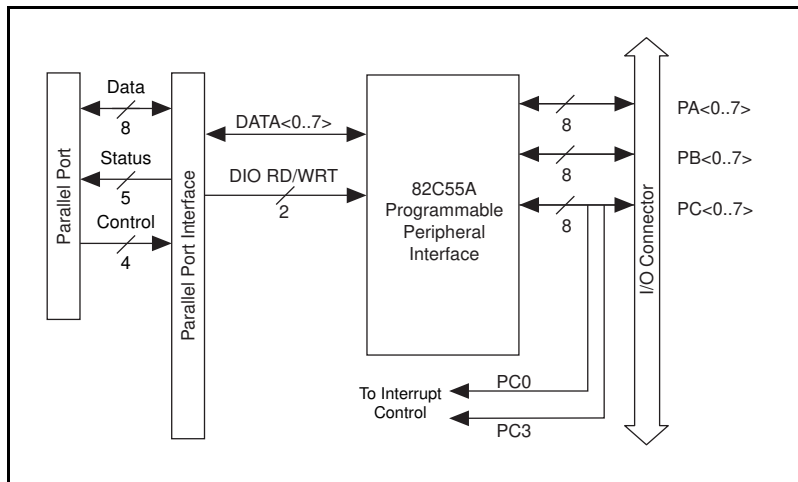

Figure 4-4. Digital I/O Circuitry Block Diagram

All three ports on the 82C55A are TTL-compatible. When enabled, the digital output ports are capable of sinking 2.4 mA of current and sourcing 2.6 mA of current on each digital I/O line. When the ports are not enabled, the digital I/O lines act as high-impedance inputs.

Timing I/O Circuitry

The SCXI-1200 uses two 82C53 counter/timer integrated circuits for DAQ timing and for general-purpose timing I/O functions. One of these is used internally for DAQ timing, and the other is available for general use. Figure 4-5 shows a block diagram of both groups of timing I/O circuitry (counter groups A and B).

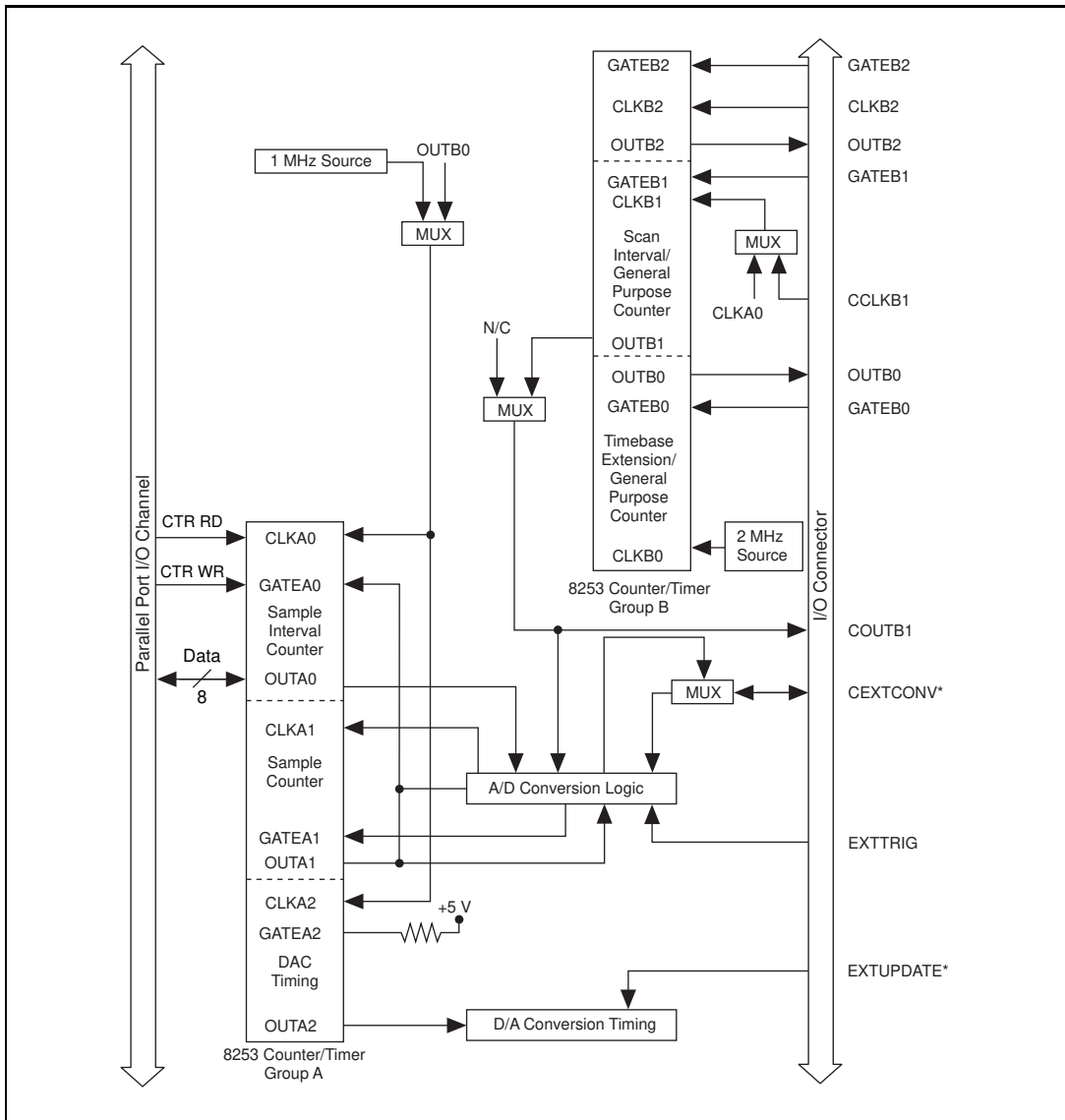

Figure 4-5. Timing I/O Circuitry Block Diagram

Each 82C53 contains three independent 16-bit counter/timers and one 8-bit Mode Register. As shown in Figure 4-5, counter group A is reserved for DAQ timing, and counter group B is free for general use.

The output of counter B0 can be used in place of the 1 MHz clock source on counter A0 to allow clock periods greater than 65,536 μs .

The 82C53 for counter group A uses either a 1 MHz clock generated from the onboard 10 MHz oscillator or the output from counter B0, which has a 2 MHz clock source, for its timebase. Optionally, you can use counter B1 to provide interval-scanning timing. In the interval-scanning mode, the CLK pin of counter B1 is driven by the same signal that is driving CLKA0. The OUTB1 pin on the I/O connector initiates scan sequences that are separated by a programmable scan interval time. The timebases for counters B1 and B2 must be supplied externally through the 50-pin I/O connector.

Figure 4-6 shows an example of interval-scanning timing.

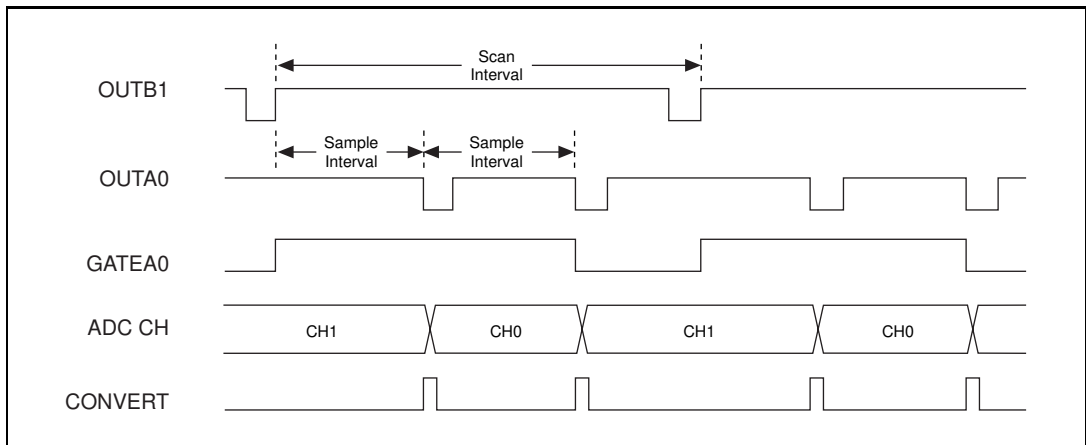

Figure 4-6. Two-Channel Interval-Scanning Timing

The single-channel interval acquisition mode makes use of an additional 8-bit counter, the interval counter. In this mode, counter B1 initiates scan sequences that are separated by a programmable interval time. The interval counter is programmed for the number of samples of the selected channel in each interval. Figure 4-7 shows an example of single-channel interval timing. In this example, counter B1 is programmed for the sample interval and the interval counter is programmed to count three samples, wait for the duration of the scan interval, count three samples, and so on. The acquisition operation ends when the sample counter (counter A1) decrements to 0.

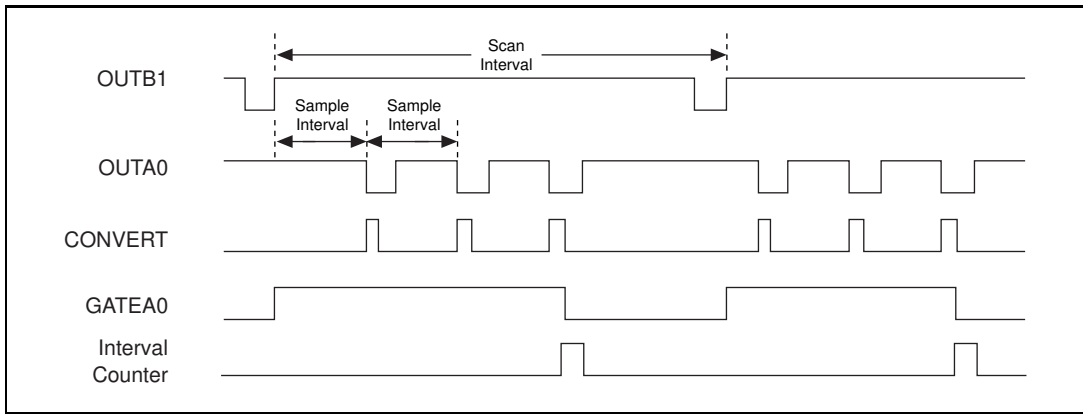

Figure 4-7. Single-Channel Interval Timing

SCXI Digital Interface

Figure 4-8 shows a diagram of the SCXI-1200 and SCXIbus digital interface circuitry.

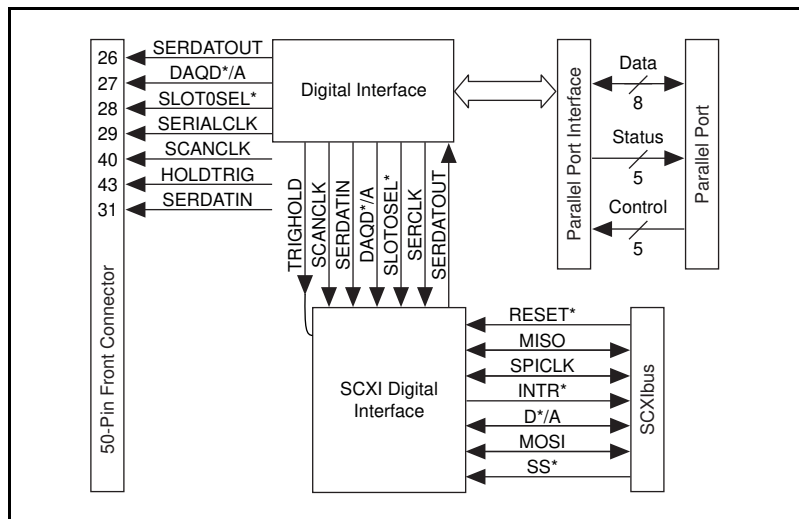

Figure 4-8. Digital Interface Circuitry Block Diagram

The circuitry is divided into an SCXI digital interface section and a rear connector interface section.

The SCXI digital interface buffers signals from the SCXibus to the module and drives signals from the module onto the SCXibus.

The digital interface comprises the 82C55A programmable peripheral interface along with buffers. All the SCXI control signals that tap into the 82C55A DIO lines also appear on the 50-pin front connector. You can program another chassis through the 50-pin front connector using an SCXI-1341, SCXI-1342, or SCXI-1344 cable assembly.

SCXI Scanning Modes

The SCXI-1200 has two basic types of scanning modes—single-module parallel scanning and multiple-module multiplexed scanning.

Single-Module Parallel Scanning

Single-module parallel scanning is the simplest scanning mode. Figure 4-9 illustrates this mode. For more information about single-module parallel scanning, refer to the sections titled *Single-Channel Data Acquisition* and *Multiple-Channel (Scanned) Data Acquisition* earlier in this chapter.

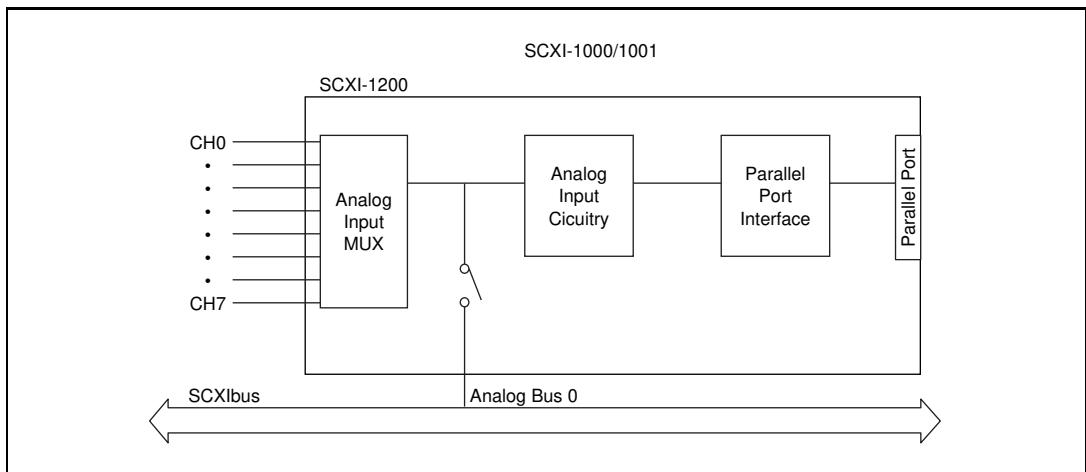

Figure 4-9. Single-Module Parallel Scanning

Multiple-Module Multiplexed Scanning

During multiplexed scanning, the SCXI-1200 provides the SCANCLK signal to Slot 0 over the TRIG0 backplane line, and Slot 0 provides the SCANCON signal to the modules. Slot 0 contains a module list FIFO

(first-in first-out) memory chip, similar to the Channel/Gain FIFO on an MIO-16 DAQ board, except that instead of having a channel number and gain setting for each entry, it contains a slot number and a sample count for each entry. The list in Slot 0 determines which module is being accessed and for how many samples. It is important to make sure that the lists on the DAQ board and Slot 0 are compatible so that the samples are acquired as intended. Refer to your SCXI chassis manual for more information.

In this mode, all the modules tie into Analog Bus 0 and are enabled sequentially by SCANCON. Slot 0 must be programmed with the sequence of modules and the number of samples per entry.

The SCXI-1200 sends SCANCLK onto TRIG0. Slot 0 counts these SCANCLK pulses and selects the modules accordingly. When some other module is selected, its output buffers are enabled by SCANCON, so that Analog Bus 0 is driven by the output signal. At the same time, Analog Bus 0 is selected by the SCXI-1200 for acquisition. When the SCXI-1200 itself is chosen by Slot 0, the input muxes of the SCXI-1200 select the input channels on the front connector, depending on the bit setting for channel selection and gains.

Figure 4-10 shows a block diagram of multiple-module multiplexed scanning.

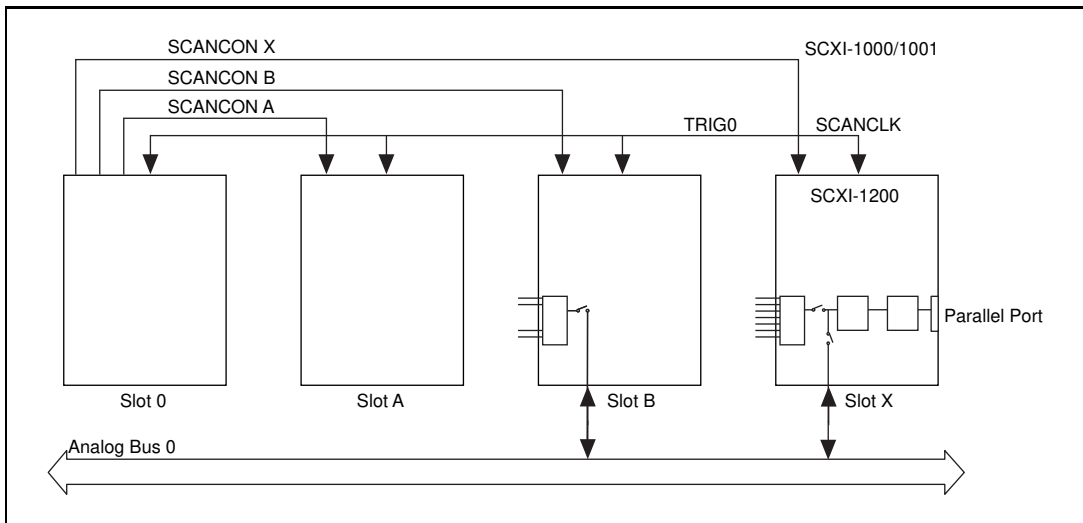

Figure 4-10. Multiple-Module Multiplexed Scanning Diagram

You can configure the SCXI-1200 module in two ways—in a stand-alone mode or a multiple-module multiplexed mode. Figure 4-11a and Figure 4-11b show both modes in standard configurations. Figure 4-11c and Figure 4-11d illustrate Remote SCXI configurations.

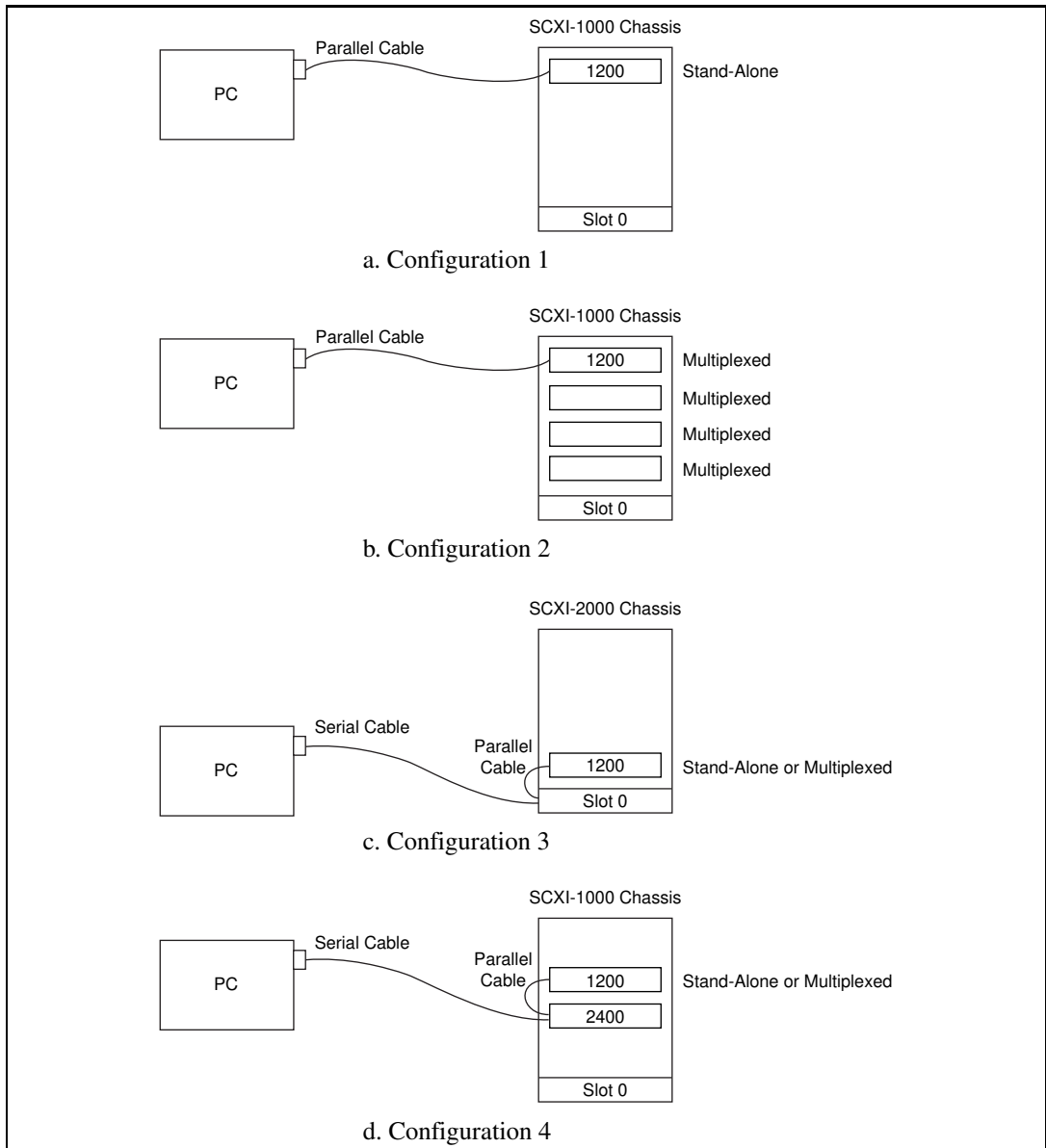

Figure 4-11. SCXI Configurations



Note: *If the SCXI-1200 is in a chassis, then it must be the master module and program Slot 0. To make the SCXI-1200 the master module, disconnect any MIO or Lab Series plug-in boards that are connected to any other SCXI modules in that chassis.*

Refer to your *SCXI-1000/1000DC/1001 Register-Level Programmer Manual* and the *SCXI-1200 Register-Level Programmer Manual* for further details about programming.

Calibration

Chapter

5

This chapter discusses the calibration of the SCXI-1200. However, the SCXI-1200 is factory calibrated, and National Instruments can recalibrate your module if needed. To maintain the 12-bit accuracy of the SCXI-1200 analog input and analog output circuitry, National Instruments recommends that you recalibrate at six-month intervals.

There are three ways to perform calibrations.

- Use the NI-DAQ `Calibrate_1200` function. This is the easiest way, because you do not need to know the details of the calibration process.
- Use the NI-DAQ functions to write to the calibration DACs and the EEPROM.
- Use your own register-level writes to the calibration DACs and the EEPROM.

If you want to perform your own calibrations using the NI-DAQ `Calibrate_1200` function, go to the *Using the Calibration Function* section later in this chapter. If you do not want to perform your own calibrations, you can skip the remainder of this chapter.

To accomplish calibration using the last two methods, you need to know the details of the calibration process. This information is in the *Calibration* chapter of the *SCXI-1200 Register-Level Programmer Manual*.

The SCXI-1200 is software calibrated, therefore there are no calibration trim pots. The module is shipped with utility software for calibration. The calibration process involves reading offset and gain errors from the analog input and analog output sections and writing values to the appropriate calibration DACs to null the errors. There are four calibration DACs associated with the analog input section and four calibration DACs associated with the analog output section, two for each output channel. After the calibration process is complete, each calibration DAC is at a known value. Because these values are lost when the board is powered down, they are also stored in the onboard EEPROM for future reference.

The factory information occupies one half of the EEPROM and is protected. The lower half of the EEPROM contains user areas for calibration data. There are eight different user areas.

When the SCXI-1200 is powered on, or the conditions under which it is operating change, you should load the calibration DACs with values from the EEPROM, or you can recalibrate the board. Calibration software is included with the SCXI-1200 as part of the NI-DAQ software.

If you use the SCXI-1200 with NI-DAQ and LabVIEW or LabWindows/CVI and do not perform user calibration, the factory calibration constants are loaded into the calibration DACs each time the module is initialized. If you do perform user calibration, you can load these user constants at startup. Therefore, the SCXI-1200 is calibrated with the most recent constants each time you perform analog input or output with the LabVIEW example VIs.

Calibration at Higher Gains

The SCXI-1200 has a maximum gain error of 0.5%. This means that if the board is calibrated at a gain of 1, and if the gain is switched to 100, a maximum of 50 mV error may result in the reading. If your application can tolerate this error, then you do not have to recalibrate at that higher gain. If this error is critical to your application, you should perform gain calibration at all other gains (2, 5, 10, 20, 50, and 100), and store the corresponding values in the other gain calibration data area. Using the `Calibrate_1200` function described later in this chapter, you can specify the gain at which the SCXI-1200 operates, and the corresponding value is loaded into the GAINCALDAC (analog input gain calibration DAC) whenever any function related to the SCXI-1200 is called. Notice that at initialization the calibration constant for the particular gain is loaded into the GAINCALDAC. This ensures a maximum error of 0.02% at all gains. Also, the factory calibration area contains gain calibration constants for all these gains.

Calibration Equipment Requirements

For best measurement results, calibrate the SCXI-1200 so that its measurement accuracy is within $\pm 0.012\%$ of its input range (± 0.5 LSB). The equipment used to calibrate the SCXI-1200 should be 10 times as accurate, that is, have $\pm 0.001\%$ rated accuracy. Calibration equipment with four times the accuracy of the item under calibration is generally considered acceptable. Four times the accuracy of the SCXI-1200 is 0.003% .

You need the following equipment to calibrate the SCXI-1200 module:

- For analog input calibration, you need a precision variable DC voltage source (usually a calibrator) with the following specifications:
 - Accuracy $\pm 0.001\%$ standard
 $\pm 0.003\%$ sufficient
 - Range Greater than ± 10 V
 - Resolution $100\ \mu\text{V}$ in ± 10 V range ($5^{1/2}$ digits)

Using the Calibration Function

NI-DAQ contains the `Calibrate_1200` function, with which you can either load the calibration DACs with the factory constants or the `USERx` constants, or perform your own calibration. To use the `Calibrate_1200` function, to perform calibration, you must ground an analog input channel at the front connector (for offset calibration) and apply an accurate voltage reference to another input channel (for gain calibration). In addition, the `DAC0` and `DAC1` outputs must be wrapped back and applied to two other analog input channels.

Specify the external voltage reference (for gain calibration) as one of the parameters of the function. The other parameters are the number of the input channel connected to `AIGND` (for pregain and postgain analog input calibration) and the input channel numbers to which `DAC0OUT` and `DAC1OUT` are fed back (for analog output calibration). Refer to the *NI-DAQ User Manual for PC Compatibles* and the *NI-DAQ Function Reference Manual for PC Compatibles* for more details on the `Calibrate_1200` function.

Specifications

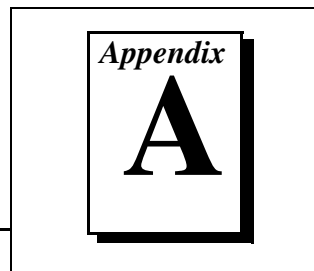

This appendix lists the specifications of the SCXI-1200. These specifications are typical at 25° C unless otherwise stated. The operating temperature range is 0° to 50° C.

Analog Input

Input Characteristics

Number of channelsEight single-ended, four differential, software selectable

Type of ADCSuccessive approximation

Resolution.....12 bits, 1 in 4,096

Conversion time
(including acquisition time)8.5 μ s

Input signal ranges

| Analog Input Signal Gain (Software Selectable) | Analog Input Signal Ranges (Software Selectable) | |
|--|--|-------------|
| | Bipolar | Unipolar |
| 1 | ± 5 V | 0 to 10 V |
| 2 | ± 2.5 V | 0 to 5 V |
| 5 | ± 1 V | 0 to 2 V |
| 10 | ± 500 mV | 0 to 1 V |
| 20 | ± 250 mV | 0 to 500 mV |
| 50 | ± 100 mV | 0 to 200 mV |
| 100 | ± 50 mV | 0 to 100 mV |

Input coupling DC

Max working voltage Input average should remain within 7 V of ground

Overvoltage protection ± 42 V powered on
 ± 15 V powered off

Inputs protected ACH0..ACH7

FIFO buffer size 2,048 samples

Data transfers Interrupts, programmed I/O

Minimum DAQ rate 1 sample every 35 minutes

Maximum sustained DAQ rates
 (typ timing data observed in LabVIEW)

| Acquisition Mode | Gain Setting | Rate | |
|------------------|--------------------------|-----------|-----------------|
| | | EPP Mode | Centronics Mode |
| Single channel | 1, 2, 5, 10, 20, 50, 100 | 100 kS/s | 25 kS/s |
| Multiple channel | 1, 2, 5, 10 | 83.3 kS/s | 25 kS/s |
| | 20 | 62.5 kS/s | 25 kS/s |
| | 50 | 55.5 kS/s | 25 kS/s |
| | 100 | 25 kS/s | 25 kS/s |

Transfer Characteristics

Relative accuracy (nonlinearity)..... ± 0.5 LSB typ, ± 1.5 LSB max

INL ± 0.5 LSB typ, ± 1 LSB max

DNL ± 0.5 LSB typ, ± 1 LSB max

No missing codes 12 bits, guaranteed

Offset error

After calibration, at all gains $\pm(5 \mu\text{V} + 0.36 \text{ mV/gain})$ max

Before calibration, at all gains $\pm(15 \text{ mV} + 150 \text{ mV/gain})$ max

Offset adjustment range ± 37 mV max

Gain error

After calibration, at all gains0.020% of reading max

Before calibration

Gain = 12% of reading max

Gain $\neq 1$ with gain error

adjusted to 0 at gain = 10.5% of reading max

Gain adjustment range ± 25 mV max

Amplifier Characteristics

Input bias current 200 pA max

Input offset current 100 pA max

Input impedance1006 Ω in parallel with 45 pF

CMRR

| Gain | CMRR DC to 60 Hz |
|-----------|------------------|
| 1 | 60 dB |
| 2 | 66 dB |
| 5 | 74 dB |
| 10 to 100 | 80 dB |

Dynamic Characteristics

Analog input bandwidth

| Gain | Single channel bandwidth |
|---------|--------------------------|
| 1 to 10 | 400 kHz |
| 20 | 200 kHz |
| 50 | 80 kHz |
| 100 | 40 kHz |

Settling time to full-scale step

| Gain | Settling time to 0.012% (± 0.5 LSB) accuracy |
|---------|---|
| 1 | 12 μ s |
| 2 to 50 | 16 μ s typ, 18 μ s max |
| 100 | 40 μ s |

System noise (including quantization error)

| Gain | Dither off | Dither on |
|---------|-------------|-------------|
| 1 to 50 | 0.3 LSB rms | 0.6 LSB rms |
| 100 | 0.6 LSB rms | 0.8 LSB rms |

Stability

Recommended warm-up time 15 min

Offset temperature coefficient $\pm(20 + 100/\text{gain}) \mu\text{V}/\text{C}$

Gain temperature coefficient $\pm 50 \text{ ppm}/\text{C}$

Explanation of Analog Input Specifications

Relative accuracy is a measure of the linearity of an ADC. However, relative accuracy is a tighter specification than a *nonlinearity* specification. Relative accuracy indicates the maximum deviation from a straight line for the analog-input-to-digital-output transfer curve. If an

ADC has been calibrated perfectly, then this straight line is the ideal transfer function, and the relative accuracy specification indicates the worst deviation from the ideal that the ADC permits.

A relative accuracy specification of ± 1 LSB is roughly equivalent to (but not the same as) a ± 0.5 LSB nonlinearity or integral nonlinearity specification because relative accuracy encompasses both nonlinearity and variable quantization uncertainty, a quantity often mistakenly assumed to be exactly ± 0.5 LSB. Although quantization uncertainty is ideally ± 0.5 LSB, it can be different for each possible digital code and is actually the analog width of each code. Thus, it is more specific to use relative accuracy as a measure of linearity than it is to use what is normally called nonlinearity, because relative accuracy ensures that the *sum* of quantization uncertainty and A/D conversion error does not exceed a given amount.

Integral nonlinearity in an ADC is an often ill-defined specification that is supposed to indicate a converter's overall A/D transfer linearity. The manufacturer of the ADC chip used by National Instruments on the DAQPad-1200 specifies its integral nonlinearity by stating that the analog center of any code will not deviate from a straight line by more than ± 1 LSB. This specification is misleading because although a particularly wide code's center may be found within ± 1 LSB of the ideal, one of its edges may be well beyond ± 1.5 LSB; thus, the ADC would have a relative accuracy of that amount. National Instruments tests its boards to ensure that they meet all three linearity specifications defined in this appendix.

Differential nonlinearity is a measure of deviation of code widths from their theoretical value of 1 LSB. The width of a given code is the size of the range of analog values that can be input to produce that code, ideally 1 LSB. A specification of ± 1 LSB differential nonlinearity ensures that no code has a width of 0 LSBs (that is, no missing codes) and that no code width exceeds 2 LSBs.

System noise is the amount of noise seen by the ADC when there is no signal present at the input of the board. The amount of noise that is reported directly (without any analysis) by the ADC is not necessarily the amount of real noise present in the system, unless the noise is considerably greater than 0.5 LSB rms. Noise that is less than this magnitude produces varying amounts of flicker, and the amount of flicker seen is a function of how near the real mean of the noise is to a code transition. If the mean is near or at a transition between codes, the ADC flickers evenly between the two codes, and the noise is very near

0.5 LSB. If the mean is near the center of a code and the noise is relatively small, very little or no flicker is seen, and the noise reported by the ADC as nearly 0 LSB. From the relationship between the mean of the noise and the measured rms magnitude of the noise, the character of the noise can be determined. National Instruments has determined that the character of the noise in the DAQPad-1200 is fairly Gaussian, so the noise specifications given are the amounts of pure Gaussian noise required to produce our readings.

Explanation of Dither

The *dither circuitry*, when enabled, adds approximately 0.5 LSB rms of white Gaussian noise to the signal to be converted to the ADC. This addition is useful for applications involving averaging to increase the resolution of the DAQPad-1200 to more than 12 bits, as in calibration. In such applications, which are often lower frequency in nature, noise modulation is decreased and differential linearity is improved by the addition of the dither. For high-speed 12-bit applications not involving averaging, dither should be disabled because it only adds noise.

When taking DC measurements, such as when calibrating the board, enable dither and average about 1,000 points to take a single reading. This process removes the effects of 12-bit quantization and reduces measurement noise, resulting in improved resolution. Dither, or additive white noise, has the effect of forcing quantization noise to become a zero-mean random variable rather than a deterministic function of input. For more information on the effects of dither, see “Dither in Digital Audio” by John Vanderkooy and Stanley P. Lipshitz, *Journal of the Audio Engineering Society*, Vol. 35, No. 12, Dec. 1987.

Explanation of DAQ Rates

Maximum DAQ rates (number of samples per second) are determined by the conversion period of the ADC plus the sample-and-hold acquisition time, which is specified at 8.5 μ s. For single channel sustained data acquisition, the maximum DAQ rate is limited by the speed of the parallel port, 100 kS/s for EPP and 25 kS/s for Centronics, and by the serial port baud rate if using Remote SCXI. During multiple-channel scanning, the DAQ rates are further limited by the settling time of the input multiplexers and programmable gain amplifier. After the input multiplexers are switched, the amplifier must be allowed to settle to the new input signal value to within 12-bit accuracy. The settling time is a function of the gain selected.

Analog Output

Output Characteristics

| | |
|--|---|
| Number of output channels | Two single-ended |
| Resolution..... | 12 bits, 1 part in 4,096 |
| Update rate (typ timing data observed in LabVIEW) | 8 kS/s in EPP mode, 4 kS/s with standard Centronics port |
| Type of DAC | Double-buffered |
| Data transfers | Interrupts, programmed I/O |

Transfer Characteristics

| | |
|------------------------------------|--|
| Relative accuracy (INL)..... | ± 0.25 LSB typ, ± 0.50 LSB max |
| DNL..... | ± 0.25 LSB typ, ± 0.75 LSB max |
| Monotonicity | 12 bits, guaranteed |
| Offset error | |
| After calibration | ± 0.2 mV max |
| Before calibration..... | ± 50 mV max |
| Offset adjustment range, min | ± 37 mV |
| Gain error | |
| After calibration | 0.004% of reading max |
| Before calibration..... | $\pm 1\%$ of reading max |
| Gain adjustment range, min | ± 100 mV |

Voltage output

| | |
|------------------------|---|
| Ranges | 0 to +10 V, ± 5 V, software selectable |
| Output coupling | DC |
| Output impedance | 0.2 Ω |

| | |
|----------------------|---|
| Current drive | ± 2 mA |
| Protection | Short circuit to ground |
| Power-on state | 0 V in bipolar mode, 5 V in unipolar mode |

Dynamic Characteristics

| | |
|--------------------------------------|--------------------------------|
| Settling time to 0.012% | 6 μ s for 10 V step |
| Slew rate | 10 V/ μ s |
| Offset temperature coefficient | ± 60 μ V/ $^{\circ}$ C |
| Gain temperature coefficient | ± 10 ppm/ $^{\circ}$ C |

Explanation of Analog Output Specifications

Relative accuracy in a D/A system is the same as nonlinearity because no uncertainty is added due to code width. Unlike an ADC, every digital code in a D/A system represents a specific analog value rather than a range of values. The relative accuracy of the system is therefore limited to the worst-case deviation from the ideal correspondence (a straight line), excepting noise. If a D/A system has been calibrated perfectly, then the relative accuracy specification reflects its worst-case absolute error.

Differential nonlinearity in a D/A system is a measure of deviation of code width from 1 LSB. In this case, code width is the difference between the analog values produced by consecutive digital codes. A specification of ± 1 LSB differential nonlinearity ensures that the code width is always greater than 0 LSBs (guaranteeing monotonicity) and is always less than 2 LSBs.

Digital I/O

| | |
|--------------------------|-----|
| Number of channels | 24 |
| Compatibility | TTL |

Digital logic levels

| Level | Min | Max |
|-------------------------------|---------|-------------|
| Input low voltage | - 0.3 V | 0.8 V |
| Input high voltage | 2.2 V | 5.3 V |
| Output low voltage (2.5 mA) | — | 0.4 μ A |
| Output high voltage (-2.5 mA) | 3.7 V | — |
| Absolute max voltage | - 0.5 V | 5.5 V |

Handshaking3 wire, 2 ports

Power-on stateInputs

Data TransfersProgrammed I/O, interrupts

Timing I/O

Number of channelsThree 16-bit counter/timers
(uses two 82C53 STCs)

Resolution counter/timers16 bits

CompatibilityTTL, counter gate and clock
inputs are pulled up with 10 k Ω
resistors onboard.

Base clocks available2 MHz

Base clock accuracy $\pm 0.01\%$

Max source frequency8 MHz

Min source pulse duration60 ns

Min gate pulse duration50 ns

Digital logic levels

| Level | Min | Max |
|-----------------------------|---------|-------|
| Input low voltage | - 0.3 V | 0.8 V |
| Input high voltage | 2.2 V | 5.3 V |
| Output low voltage (4 mA) | — | 0.4 V |
| Output high voltage (-1 mA) | 3.7 V | — |
| Absolute max voltage | - 0.5 V | 5.5 V |

Parallel Port

Types Compatible with Centronics and Enhanced parallel port (EPP)

Throughput 41 kBytes/s Centronics, 180 kBytes/s EPP

Power Requirement

+5 VDC..... 50 mA

V+ DC..... 81 mA

V- DC 40.25 mA

The SCXI-1000 chassis supplies a maximum of 200 mA current on the 5 V power supply and the SCXI-1001 supplies a minimum of 600 mA on the 5 V power supply. Because the SCXI-1000 has four slots and the SCXI-1001 has 12 slots, each module can draw a maximum of 200/4 or 600/12, which is 50 mA current on the 5 V line. However, if any slot is unoccupied, other modules can use its share of the 50 mA. The +5 V on the front connector can thus supply a current equal to 50 mA * (number of unoccupied slots). This is the unused +5 V power. If all of the slots are occupied, you must not use this +5 V to drive external circuitry. The SCXI-1000 chassis is fused by a 1 A fuse, available from Allied Electronics, part number 845-2007, or Littelfuse, part number 251001.

Physical

| | |
|------------------|--|
| Dimensions | 1.2 by 6.8 by 8.0 in. (3 by 17.3 by 20.3 cm) |
| Connectors | 50-pin male ribbon-cable front connector 25-pin female Centronics type B rear connector |

Environment

| | |
|-----------------------------|-------------------------|
| Operating temperature | 0° to 70° C |
| Storage temperature | -55° to 150° C |
| Relative humidity | 5% to 90% noncondensing |

Installation Troubleshooting

Appendix B

This appendix contains installation troubleshooting information.

1. The NI-DAQ Configuration Utility reports an error when I try to save the settings.

Check the following items if you receive this message:

“WDAQCONF could not find the device being configured on the LPT at address 0xXXX. Check your LPT base address and your LPT connections and retry.”

- a. Make sure your chassis is switched on and the screws of the cable are tightly fastened.
- b. Check that your base address is correct. This can be done either by checking your computer technical manual or, in some cases, by checking the base address jumper. In Windows applications, you may have a Hardware Control panel that will allow you to enable and disable the parallel port. Common parallel port addresses are 0x378, 0x278, 0x3BC, 0x280, and 0x290.



Note:

If your parallel port address does not appear under the Base Addr window in WDAQCONF, you must turn off the Auto Test option under the Options menu in the main window to access the other parallel port addresses.

- c. Check that you are using the included 1 m parallel port cable. If you suspect that you have a bad parallel port cable, replace with a new cable or one that you know works with another peripheral. If you are using another parallel port cable, check to make sure it meets the required specifications (see the note under item 2b).
- d. If you are still having problems, please report the computer make and model number to National Instruments. If you have a noncompatible parallel port and you have an available slot for a plug-in board, try using the Far Point EPP card described in the *Optional Equipment* section of Chapter 1, *Introduction*.

Check the following items if you receive this message:

“The device is not responding to the selected interrupt (IRQA). If the IRQ on your board is jumper configurable, make sure that the jumper settings correspond to the interrupt you have selected. If they do, you will have to try a different interrupt level.”

- a. IRQ levels 7 and 5 are the most common interrupt levels reserved for the parallel port. Try saving your configuration for both IRQ7 and IRQ5.



Note: *If either IRQ level 7 or 5 are unselectable under the IRQ menu in WDAQCONF, then another National Instruments board is using this interrupt. You will have to free the appropriate IRQ level to allocate it for your parallel port.*

- b. You may have an interrupt conflict with a non-National Instruments device. If you have installed a PCMCIA card or a plug-in board, you will have to ensure that IRQ5 or IRQ7 have not been allocated for these devices.



Note: *For some PCMCIA cards installed with Cardware, it may be possible to exclude your parallel port interrupt level by including the line XIRQ=7, E for IRQ 7 or XIRQ=5, E for IRQ 5 in the cardware.ini file.*

- c. You may have an interrupt conflict with a Windows-based application. You will have to ensure that IRQ5 or IRQ7 have not been allocated for this application. One place to search is your system.ini file under Windows.
 - d. If you are still having problems, please report the computer make and model number to National Instruments.
2. The configuration utility works fine when I use a 1 m parallel port cable but reports an error when I try to use a longer parallel port cable.
 - a. Ensure that your parallel port cable meets the required specifications. (See the note under item 2b.)
 - b. You may have to use a unidirectional parallel port extender in order to achieve long distance solutions (one such extender is made by BRAVO Communications). Your parallel port will be recognized as a Centronics port with this extender.



Note: *National Instruments does not guarantee functionality with parallel port cables longer than 1 m.*

3. I have an EPP port, but the configuration utility reports that I have a Centronics port when I try to save the configuration settings.
 - a. You may have to enable your parallel port as an EPP port. Check for such utilities and ensure that your port is configured for EPP.
 - b. It is possible that your EPP port does not meet the EPP specifications as given by the 1284 IEEE parallel port specifications. In this case, your parallel port will be treated as a Centronics port.



Note: *Your parallel port cable should meet the following specifications:*

- *Characteristic unbalanced impedance of each signal and ground pair of $62 \Omega \pm 6 \Omega$, 4 to 16 MHz*
- *Unbalanced capacitance of each cable pair less than 107 pF/m at 1 MHz*
- *DC resistance of each cable wire of less than 0.22 Ω /m*
- *Total propagation of each cable wire of less than 150 ns*

Customer Communication

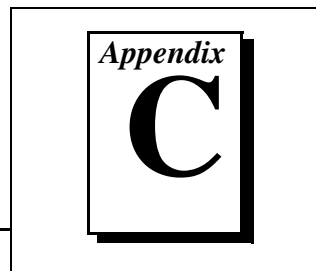

For your convenience, this appendix contains forms to help you gather the information necessary to help us solve your technical problems and a form you can use to comment on the product documentation. When you contact us, we need the information on the Technical Support Form and the configuration form, if your manual contains one, about your system configuration to answer your questions as quickly as possible.

National Instruments has technical assistance through electronic, fax, and telephone systems to quickly provide the information you need. Our electronic services include a bulletin board service, an FTP site, a FaxBack system, and e-mail support. If you have a hardware or software problem, first try the electronic support systems. If the information available on these systems does not answer your questions, we offer fax and telephone support through our technical support centers, which are staffed by applications engineers.

Electronic Services



Bulletin Board Support

National Instruments has BBS and FTP sites dedicated for 24-hour support with a collection of files and documents to answer most common customer questions. From these sites, you can also download the latest instrument drivers, updates, and example programs. For recorded instructions on how to use the bulletin board and FTP services and for BBS automated information, call (512) 795-6990. You can access these services at:

United States: (512) 794-5422

Up to 14,400 baud, 8 data bits, 1 stop bit, no parity

United Kingdom: 01635 551422

Up to 9,600 baud, 8 data bits, 1 stop bit, no parity

France: 1 48 65 15 59

Up to 9,600 baud, 8 data bits, 1 stop bit, no parity



FTP Support

To access our FTP site, log on to our Internet host, `ftp.natinst.com`, as anonymous and use your Internet address, such as `joesmith@anywhere.com`, as your password. The support files and documents are located in the `/support` directories.



FaxBack Support

FaxBack is a 24-hour information retrieval system containing a library of documents on a wide range of technical information. You can access FaxBack from a touch-tone telephone at (512) 418-1111.



E-Mail Support (currently U.S. only)

You can submit technical support questions to the appropriate applications engineering team through e-mail at the Internet addresses listed below. Remember to include your name, address, and phone number so we can contact you with solutions and suggestions.

GPIB: gpib.support@natinst.com

LabVIEW: lv.support@natinst.com

DAQ: daq.support@natinst.com

Lookout: lookout.support@natinst.com

VXI: vxi.support@natinst.com

HiQ: hiq.support@natinst.com

LabWindows: lw.support@natinst.com

VISA: visa.support@natinst.com

Fax and Telephone Support

National Instruments has branch offices all over the world. Use the list below to find the technical support number for your country. If there is no National Instruments office in your country, contact the source from which you purchased your software to obtain support.



Telephone



Fax

| | | |
|------------------|-----------------|------------------|
| Australia | 03 9879 5166 | 03 9879 6277 |
| Austria | 0662 45 79 90 0 | 0662 45 79 90 19 |
| Belgium | 02 757 00 20 | 02 757 03 11 |
| Canada (Ontario) | 905 785 0085 | 905 785 0086 |
| Canada (Quebec) | 514 694 8521 | 514 694 4399 |
| Denmark | 45 76 26 00 | 45 76 26 02 |
| Finland | 09 527 2321 | 09 502 2930 |
| France | 01 48 14 24 24 | 01 48 14 24 14 |
| Germany | 089 741 31 30 | 089 714 60 35 |
| Hong Kong | 2645 3186 | 2686 8505 |
| Israel | 03 5734815 | 03 5734816 |
| Italy | 02 413091 | 02 41309215 |
| Japan | 03 5472 2970 | 03 5472 2977 |
| Korea | 02 596 7456 | 02 596 7455 |
| Mexico | 5 520 2635 | 5 520 3282 |
| Netherlands | 0348 433466 | 0348 430673 |
| Norway | 32 84 84 00 | 32 84 86 00 |
| Singapore | 2265886 | 2265887 |
| Spain | 91 640 0085 | 91 640 0533 |
| Sweden | 08 730 49 70 | 08 730 43 70 |
| Switzerland | 056 200 51 51 | 056 200 51 55 |
| Taiwan | 02 377 1200 | 02 737 4644 |
| U.K. | 01635 523545 | 01635 523154 |

Technical Support Form

Photocopy this form and update it each time you make changes to your software or hardware, and use the completed copy of this form as a reference for your current configuration. Completing this form accurately before contacting National Instruments for technical support helps our applications engineers answer your questions more efficiently.

If you are using any National Instruments hardware or software products related to this problem, include the configuration forms from their user manuals. Include additional pages if necessary.

Name _____

Company _____

Address _____

Fax (____) _____ Phone (____) _____

Computer brand _____ Model _____ Processor _____

Operating system (include version number) _____

Clock speed _____MHz RAM _____MB Display adapter _____

Mouse ___yes ___no Other adapters installed _____

Hard disk capacity _____MB Brand _____

Instruments used _____

National Instruments hardware product model _____ Revision _____

Configuration _____

National Instruments software product _____ Version _____

Configuration _____

The problem is: _____

List any error messages: _____

The following steps reproduce the problem: _____

SCXI-1200 Hardware and Software Configuration Form

Record the settings and revisions of your hardware and software on the line to the right of each item. Complete a new copy of this form each time you revise your software or hardware configuration, and use this form as a reference for your current configuration. Completing this form accurately before contacting National Instruments for technical support helps our applications engineers answer your questions more efficiently.

National Instruments Products

Interrupt level of SCXI-1200 _____

Analog Output Channel 0 Configuration _____
(Factory Setting—Bipolar)

Analog Output Channel 1 Configuration _____
(Factory Setting—Bipolar)

Analog Input Configuration _____
(Factory Setting—Bipolar)

NI-DAQ or LabWindows/CVI version _____

Other Products

Microprocessor _____

Clock frequency _____

Computer make and model _____

Type of video board installed _____

Operating system _____

Operating system version _____

Programming language _____

Programming language version _____

Other boards in system _____

Base I/O address of other boards _____

DMA channels of other boards _____

Interrupt level of other boards _____

Documentation Comment Form

National Instruments encourages you to comment on the documentation supplied with our products. This information helps us provide quality products to meet your needs.

Title: *SCXI-1200 User Manual*

Edition Date: December 1996

Part Number: 371186A-01

Please comment on the completeness, clarity, and organization of the manual.

If you find errors in the manual, please record the page numbers and describe the errors.

Thank you for your help.

Name _____

Title _____

Company _____

Address _____

Phone (____) _____ Fax (____) _____

Mail to: Technical Publications
National Instruments Corporation
6504 Bridge Point Parkway
Austin, TX 78730-5039

Fax to: Technical Publications
National Instruments Corporation
(512) 794-5678

| Prefix | Meaning | Value |
|---------------|----------------|--------------|
| p- | pico- | 10^{-12} |
| n- | nano- | 10^{-9} |
| μ - | micro- | 10^{-6} |
| m- | milli- | 10^{-3} |
| k- | kilo- | 10^3 |
| M- | mega- | 10^6 |
| G- | giga- | 10^9 |

Symbols

| | |
|----------|--------------------------|
| > | greater than |
| \geq | greater than or equal to |
| < | less than |
| % | percent |
| + | positive of, or plus |
| - | negative of, or minus |
| / | per |
| ° | degree |
| \pm | plus or minus |
| Ω | ohms |

A

| | |
|--------------------|---|
| A | amperes |
| AC | alternating current |
| ACH<0..7> | Analog Channel signal |
| ACK* | Acknowledge Input signal |
| A/D | analog-to-digital |
| ADC | analog-to-digital converter—an electronic device, often an integrated circuit, that converts an analog voltage to a digital number |
| ADC resolution | the resolution of the ADC, which is measured in bits. An ADC with 16 bits has a higher resolution, and thus a higher degree of accuracy, than a 12-bit ADC. |
| AGND | Analog Ground signal |
| AISENSE/AIGND | Analog Input Sense/Analog Input Ground signal |
| alias | a false lower frequency component that appears in sampled data acquired at too low a sampling rate |
| amplification | a type of signal conditioning that improves accuracy in the resulting digitized signal and reduces noise |
| amplitude flatness | a measure of how close to constant the gain of a circuit remains over a range of frequencies |
| ANSI | American National Standards Institute |
| asynchronous | (1) hardware—a property of an event that occurs at an arbitrary time, without synchronization to a reference clock (2) software—a property of a function that begins an operation and returns prior to the completion or termination of the operation |
| AWG | American Wire Gauge |

B

| | |
|--------------|---|
| b | bit—one binary digit, either 0 or 1 |
| B | byte—eight related bits of data, an eight-bit binary number; also used to denote the amount of memory required to store one byte of data |
| base address | a memory address that serves as the starting address for programmable registers; all other addresses are located by adding to the base address. |
| baud rate | serial communications data transmission rate expressed in bits per second (b/s) |
| binary | a number system with a base of 2 |
| BIOS | basic input/output system—BIOS functions are the fundamental level of any PC or compatible computer. BIOS functions embody the basic operations needed for successful use of the computer's hardware resources. |
| bipolar | a signal range that includes both positive and negative values (for example, -5 V to +5 V) |
| buffer | temporary storage for acquired or generated data |
| bus | the group of conductors that interconnect individual circuitry in a computer. Typically, a bus is the expansion vehicle to which I/O or other devices are connected. Examples of PC buses are the AT bus, NuBus, Micro Channel, and EISA bus. |

C

| | |
|-----------|--|
| C | Celsius |
| CalDAC | Calibration DAC |
| cascading | process of extending the counting range of a counter chip by connecting to the next higher counter |
| CCLKB1 | Counter B1 Clock signal |

| | |
|-----------------------|---|
| channel | pin or wire lead to which you apply or from which you read the analog or digital signal. Analog signals can be single-ended or differential. For digital signals, you group channels to form ports. Ports usually consist of either four or eight digital channels. |
| circuit trigger | a condition for starting or stopping clocks |
| CLKB2 | Counter B2 Clock signal |
| clock | hardware component that controls timing for reading from or writing to groups |
| cm | centimeters |
| CMOS | complementary metal-oxide semiconductor |
| CMRR | common-mode rejection ratio—A measure of an instrument’s ability to reject interference from a common-mode signal, usually expressed in decibels (dB). |
| code width | the smallest detectable change in an input voltage of a DAQ device |
| common-mode range | the input range over which a circuit can handle a common-mode signal |
| common-mode signal | the mathematical average voltage, relative to the computer’s ground, of the signals from a differential input |
| common-mode voltage | any voltage present at the instrumentation amplifier inputs with respect to amplifier ground |
| conditional retrieval | a method of triggering in which you simulate an analog trigger using software. Also called software triggering. |
| conversion device | device that transforms a signal from one form to another. For example, analog-to-digital converters (ADCs) for analog input, digital-to-analog converters (DACs) for analog output, digital input or output ports, and counter/timers are conversion devices. |
| conversion time | the time required, in an analog input or output system, from the moment a channel is interrogated (such as with a read instruction) to the moment that accurate data is available |
| counter/timer | a circuit that counts external pulses or clock pulses (timing) |

| | |
|--------------------------|--|
| coupling | the manner in which a signal is connected from one location to another |
| COUTB1 | Counter B1 Output signal |
| crosstalk | an unwanted signal on one channel due to an input on a different channel |
| current drive capability | the amount of current a digital or analog output channel is capable of sourcing or sinking while still operating within voltage range specifications |
| current sinking | the ability of a DAQ board to dissipate current for analog or digital output signals |
| current sourcing | the ability of a DAQ board to supply current for analog or digital output signals |

D

| | |
|---------|--|
| D/A | digital-to-analog |
| D*/A | Data/Address signal |
| DAC | digital-to-analog converter—an electronic device, often an integrated circuit, that converts a digital number into a corresponding analog voltage or current |
| DAC0OUT | Digital-to-Analog Converter 0 and 1 Output signal |
| DAQ | data acquisition—(1) collecting and measuring electrical signals from sensors, transducers, and test probes or fixtures and inputting them to a computer for processing; (2) collecting and measuring the same kinds of electrical signals with A/D and/or DIO boards plugged into a computer, and possibly generating control signals with D/A and/or DIO boards in the same computer |
| DAQD*/A | Data acquisition board data/address line signal |
| DATA | Data Lines at the Specified Port signal |
| dB | decibel—the unit for expressing a logarithmic measure of the ratio of two signal levels: $dB=20\log_{10} V1/V2$, for signals in volts |

| | |
|---------------------------------|--|
| DC | direct current |
| default setting | a default parameter value recorded in the driver. In many cases, the default input of a control is a certain value (often 0) that means <i>use the current default setting</i> . For example, the default input for a parameter may be <i>do not change current setting</i> . If you do change the value of such a parameter, the new value becomes the new setting. You can set default settings for some parameters in the configuration utility or manually using switches located on the device. |
| device | a plug-in data acquisition board, card, or pad that can contain multiple channels and conversion devices. Plug-in boards, PCMCIA cards, and devices such as the DAQPad-1200, which connects to your computer parallel port, are all examples of DAQ devices. SCXI modules are distinct from devices, with the exception of the SCXI-1200, which is both a module and a device. |
| DIFF | differential mode |
| differential input | an analog input consisting of two terminals, both of which are isolated from computer ground, whose difference is measured |
| differential measurement system | a way you can configure your device to read signals, in which you do not need to connect either input to a fixed reference, such as the earth or a building ground |
| digital port | <i>See</i> port. |
| DIN | Deutsche Industrie Norme |
| DIO | digital input/output |
| DGND | digital ground signal |
| DNL | differential nonlinearity—a measure in LSB of the worst-case deviation of code widths from their ideal value of 1 LSB |
| DOS | disk operating system |
| drivers | software that controls a specific hardware device such as a DAQ board or a GPIB interface board |

dynamic range the ratio of the largest signal level a circuit can handle to the smallest signal level it can handle (usually taken to be the noise level), normally expressed in dB

E

EEPROM electrically erased programmable read-only memory—ROM that can be erased with an electrical signal and reprogrammed

EMC electromechanical compliance

external trigger a voltage pulse from an external source that triggers an event such as A/D conversion

EXTCONV* External Convert signal

EXTTRIG External Trigger signal

EXTUPDATE* External Update signal

F

FIFO first-in first-out memory buffer—the first data stored is the first data sent to the acceptor. FIFOs are often used on DAQ devices to temporarily store incoming or outgoing data until that data can be retrieved or output. For example, an analog input FIFO stores the results of A/D conversions until the data can be retrieved into system memory, a process that requires the servicing of interrupts and often the programming of the DMA controller. This process can take several milliseconds in some cases. During this time, data accumulates in the FIFO for future retrieval. With a larger FIFO, longer latencies can be tolerated. In the case of analog output, a FIFO permits faster update rates, because the waveform data can be stored on the FIFO ahead of time. This again reduces the effect of latencies associated with getting the data from system memory to the DAQ device.

filtering a type of signal conditioning that allows you to filter unwanted signals from the signal you are trying to measure

floating signal sources signal sources with voltage signals that are not connected to an absolute reference or system ground. Also called nonreferenced signal sources. Some common example of floating signal sources are batteries, transformers, or thermocouples.

ft feet

G

Gabor Spectrogram a new algorithm for joint time-frequency analysis that uses the discrete Gabor transform. The Gabor Spectrogram produces a three-dimensional plot of signal power versus frequency and time. Used in sonar, acoustics, and vibration analysis.

gain the factor by which a signal is amplified, sometimes expressed in decibels

gain accuracy a measure of deviation of the gain of an amplifier from the ideal gain

GATB<0..2> Counter B0, B1, and B2 gate signals

GATE input pin a counter input pin that controls when counting occurs in your application

grounded measurement system *See* referenced single-ended mode.

H

handshaked digital I/O a type of digital acquisition/generation where a device or module accepts or transfers data after a digital pulse has been received. Also called latched digital I/O.

hardware the physical components of a computer system, such as the circuit boards, plug-in boards, chassis, enclosures, peripherals, cables, and so on

hardware triggering a form of triggering where you set the start time of an acquisition and gather data at a known position in time relative to a trigger signal.

hex hexadecimal

| | |
|---------------------------|---|
| Hz | hertz—the number of scans read or updates written per second |
| I | |
| IBF | Input Buffer Full signal |
| in. | inches |
| INL | integral nonlinearity—a measure in LSB of the worst-case deviation from the ideal A/D or D/A transfer characteristic of the analog I/O circuitry |
| input bias current | the current that flows into the inputs of a circuit |
| input impedance | the measured resistance and capacitance between the input terminals of a circuit |
| input offset current | the difference in the input bias currents of the two inputs of an instrumentation amplifier |
| instrumentation amplifier | a circuit whose output voltage with respect to ground is proportional to the difference between the voltages at its two inputs |
| interrupt | a computer signal indicating that the CPU should suspend its current task to service a designated activity |
| interrupt level | the relative priority at which a device can interrupt |
| interval scanning | scanning method where there is a longer interval between scans than there is between individual channels comprising a scan |
| INTR | Interrupt Request signal |
| I/O | input/output—the transfer of data to/from a computer system involving communications channels, operator interface devices, and/or data acquisition and control interfaces |
| IOH | current, output high |
| IOL | current, output low |
| IRQ | interrupt request |
| ISA | industry standard architecture |

K

| | |
|----------|--|
| k | kilo—the standard metric prefix for 1,000, or 10^3 , used with units of measure such as volts, hertz, and meters |
| K | kilo—the prefix for 1,024, or 2^{10} , used with B in quantifying data or computer memory |
| kbytes/s | a unit for data transfer that means 1,000 or 10^3 bytes/s |
| kS | 1,000 samples |

L

| | |
|---------------------|---|
| latched digital I/O | a type of digital acquisition/generation where a device or module accepts or transfers data after a digital pulse has been received. Also called handshaked digital I/O. |
| library | a file containing compiled object modules, each comprised of one or more functions, that can be linked to other object modules that make use of these functions. NIDAQMSC.LIB is a library that contains NI-DAQ functions. The NI-DAQ function set is broken down into object modules so that only the object modules that are relevant to your application are linked in, while those object modules that are not relevant are not linked. |
| linearity | the adherence of device response to the equation $R = KS$, where R = response, S = stimulus, and K = a constant |
| LSB | least significant bit |

M

| | |
|-----|---|
| m | meters |
| M | (1) mega, the standard metric prefix for 1 million or 10^6 , when used with units of measure such as volts and hertz; (2) mega, the prefix for 1,048,576, or 2^{20} , when used with B to quantify data or computer memory. |
| max | maximum |
| MB | megabytes of memory |

| | |
|------------------|---|
| memory buffer | <i>See</i> buffer. |
| min | minimum |
| MIO | multifunction I/O |
| MSB | most significant bit |
| MTBF | mean time between failure |
| multiplexed mode | an SCXI operating mode in which analog input channels are multiplexed into one module output so that your cabled DAQ device has access to the module's multiplexed output as well as the outputs on all other multiplexed modules in the chassis through the SCXI bus. Also called serial mode. |
| mux | multiplexer—a switching device with multiple inputs that sequentially connects each of its inputs to its output, typically at high speeds, in order to measure several signals with a single analog input channel |

N

| | |
|------------------------------|--|
| NI-DAQ | NI driver software for DAQ hardware |
| noise | an undesirable electrical signal. Noise comes from external sources such as the AC power line, motors, generators, transformers, fluorescent lights, soldering irons, CRT displays, computers, electrical storms, welders, radio transmitters, and internal sources such as semiconductors, resistors, and capacitors. Noise corrupts signals you are trying to send or receive. |
| nonlatched digital I/O | a type of digital acquisition/generation where LabVIEW updates the digital lines or port states immediately or returns the digital value of an input line. Also called immediate digital I/O or non-handshaking. |
| nonreferenced signal sources | signal sources with voltage signals that are not connected to an absolute reference or system ground. Also called floating signal sources. Some common example of nonreferenced signal sources are batteries, transformers, or thermocouples. |

NRSE nonreferenced single-ended mode—all measurements are made with respect to a common (NRSE) measurement system reference, but the voltage at this reference can vary with respect to the measurement system ground

Nyquist Sampling Theorem a law of sampling theory stating that if a continuous bandwidth-limited signal contains no frequency components higher than half the frequency at which it is sampled, then the original signal can be recovered without distortion

O

OBF* Output Buffer Full signal

onboard channels channels provided by the plug-in data acquisition board

operating system base-level software that controls a computer, runs programs, interacts with users, and communicates with installed hardware or peripheral devices

OUTB0, OUTB1 counter B0, B1 output signals

output settling time the amount of time required for the analog output voltage to reach its final value within specified limits

output slew rate the maximum rate of change of analog output voltage from one level to another

P

PA, PB, PC<0..7> Port A, B, or C 0 through 7 signal

parallel mode a type of SCXI operating mode in which the module sends each of its input channels directly to a separate analog input channel of the device to the module

PGIA programmable gain instrumentation amplifier

port (1) a communications connection on a computer or a remote controller (2) a digital port, consisting of four or eight lines of digital input and/or output

postriggering the technique used on a DAQ board to acquire a programmed number of samples after trigger conditions are met

| | |
|-------------------|---|
| ppm | parts per million |
| pretriggering | the technique used on a DAQ board to keep a continuous buffer filled with data, so that when the trigger conditions are met, the sample includes the data leading up to the trigger condition |
| propagation | the transmission of a signal through a computer system |
| propagation delay | the amount of time required for a signal to pass through a circuit |
| protocol | the exact sequence of bits, characters, and control codes used to transfer data between computers and peripherals through a communications channel |

Q

| | |
|--------------------|---|
| quantization error | the inherent uncertainty in digitizing an analog value due to the finite resolution of the conversion process |
|--------------------|---|

R

| | |
|---------------------------|--|
| RD* | Read signal |
| referenced signal sources | Signal sources with voltage signals that are referenced to a system ground, such as the earth or a building ground. Also called grounded signal sources. |
| relative accuracy | a measure in LSB of the accuracy of an ADC. It includes all non-linearity and quantization errors. It does not include offset and gain errors of the circuitry feeding the ADC. |
| resolution | the smallest signal increment that can be detected by a measurement system. Resolution can be expressed in bits, in proportions, or in percent of full scale. For example, a system has 12-bit resolution, one part in 4,096 resolution, and 0.0244 percent of full scale. |
| rms | root mean square |
| RSE | referenced single-ended mode—all measurements are made with respect to a common reference measurement system or a ground. Also called a grounded measurement system. |

S

| | |
|---------------------|---|
| s | seconds |
| S | samples |
| sample counter | the clock that counts the output of the channel clock, in other words, the number of samples taken. On boards with simultaneous sampling, this counter counts the output of the scan clock and hence the number of scans. |
| scan | one or more analog or digital input samples. Typically, the number of input samples in a scan is equal to the number of channels in the input group. For example, one pulse from the scan clock produces one scan which acquires one new sample from every analog input channel in the group. |
| SCXI | Signal Conditioning eXtensions for Instrumentation—the National Instruments product line for conditioning low-level signals within an external chassis near sensors so only high-level signals are sent to DAQ boards in the noisy PC environment |
| SDK | software development kit |
| SE | single-ended—a term used to describe an analog input that is measured with respect to a common ground |
| sensor | a device that responds to a physical stimulus (heat, light, sound, pressure, motion, flow, and so on), and produces a corresponding electrical signal |
| SERCLK | Serial Clock signal |
| SERDATIN | Serial Data In signal |
| SERDATOUT | Serial Data Out signal |
| settling time | the amount of time required for a voltage to reach its final value within specified limits |
| signal conditioning | the manipulation of signals to prepare them for digitizing |
| SLOT0SEL* | Slot 0 Select signal |

| | |
|---------------------|--|
| SNR | signal-to-noise ratio—the ratio of the overall rms signal level to the rms noise level, expressed in dB |
| software trigger | a programmed event that triggers an event such as data acquisition |
| software triggering | a method of triggering in which you to simulate an analog trigger using software. Also called conditional retrieval. |
| SOURCE input pin | a counter input pin where the counter counts the signal transitions |
| SPICLK | Serial Peripheral Interface Clock signal |
| SS* | Slot-Select signal |
| S/s | samples per second—used to express the rate at which a DAQ board samples an analog signal |
| strain gauge | a thin conductor, which is attached to a material, that detects stress or vibrations in that material. The conductor's resistance is a function of the applied force. |
| STB* | Strobe Input signal |
| synchronous | (1) hardware—a property of an event that is synchronized to a reference clock (2) software—a property of a function that begins an operation and returns only when the operation is complete |
| system noise | a measure of the amount of noise seen by an analog circuit or an ADC when the analog inputs are grounded |
| T | |
| THD | total harmonic distortion—the ratio of the total rms signal due to harmonic distortion to the overall rms signal, in dB or percent |
| THD+N | signal-to-THD plus noise—the ratio in decibels of the overall rms signal to the rms signal of harmonic distortion plus noise introduced |
| thermistor | a semiconductor sensor that exhibits a repeatable change in electrical resistance as a function of temperature. Most thermistors exhibit a negative temperature coefficient. |

| | |
|-----------------------|--|
| thermocouple | a temperature sensor created by joining two dissimilar metals. The junction produces a small voltage as a function of the temperature. |
| transducer | <i>See</i> sensor. |
| transducer excitation | a type of signal conditioning that uses external voltages and currents to excite the circuitry of a signal conditioning system into measuring physical phenomena |
| transfer rate | the rate, measured in bytes/s, at which data is moved from source to destination after software initialization and set up operations; the maximum rate at which the hardware can operate |
| trigger | any event that causes or starts some form of data capture |
| TTL | transistor-transistor logic |

U

| | |
|-------------|--|
| unipolar | a signal range that is always positive (for example, 0 to +10 V) |
| UP/BP* | Unipolar/bipolar bit |
| update | the output equivalent of a scan. One or more analog or digital output samples. Typically, the number of output samples in an update is equal to the number of channels in the output group. For example, one pulse from the update clock produces one update which sends one new sample to every analog output channel in the group. |
| update rate | the number of output updates per second |

V

| | |
|-----|----------------------|
| V | volts |
| VDC | volts direct current |

| | |
|----------|---|
| VI | Virtual Instrument—(1) a combination of hardware and/or software elements, typically used with a PC, that has the functionality of a classic stand-alone instrument. (2) a LabVIEW software module (VI) that consists of a front panel user interface and a block diagram program |
| V_{IH} | volts, input high |
| V_{IL} | volts, input low |
| V_{in} | volts in |
| V_{OH} | volts, output high |
| V_{OL} | volts, output low |
| W | |
| W | watts |
| waveform | multiple voltage readings taken at a specific sampling rate |
| wire | data path between nodes. |
| WR* | Write signal |

Numbers

+5 V signal, 3-4

A

ACH<0..7> signal

description (table), 3-3

input ranges and maximum ratings, 3-4

ACK* signal

description (table), 3-18

mode 1 output timing (figure), 3-20

mode 2 bidirectional timing (figure), 3-21

A/D FIFO, 4-4

ADC (analog to digital converter), 4-4

AGND signal, 3-3

AISENSE/AIGND signal

analog input signal connections, 3-4

description (table), 3-3

NRSE configuration (table), 2-7

amplifier characteristics, A-3

analog input and DAQ circuitry, 4-2 to 4-8

bipolar analog input signal range versus gain (table), 4-7 to 4-8

block diagram, 4-3

DAQ rates, 4-6 to 4-8

DAQ timing circuitry, 4-4 to 4-8

description, 4-3 to 4-4

maximum recommended data acquisition rates (table), 4-7

multiple-channel (scanned) data acquisition, 4-5 to 4-6

overview, 4-2 to 4-3

settling time versus gain (table), 4-7

single-channel data acquisition, 4-5

unipolar analog input signal range versus gain (table), 4-8

analog input configuration, 2-6 to 2-9. *See also* analog input signal connections.

bit configurations (table), 2-5

DIFF input

definition (table), 2-7

description, 2-8

factory configuration, 2-5

NRSE input

definition (table), 2-7

description, 2-8

polarity and range, 2-9

RSE input

definition (table), 2-7

description, 2-8

analog input multiplexers, 4-3

analog input signal connections, 3-4 to 3-6

common-mode signal rejection

considerations, 3-13

DIFF configuration, 3-7 to 3-8

definition, 3-7

floating signal sources, 3-9 to 3-10

grounded signal sources, 3-8 to 3-9

when to use, 3-7

single-ended signal connections

definition, 3-10

floating signal sources (RSE configuration), 3-11

grounded signal sources (NRSE configuration), 3-11 to 3-12

when to use, 3-10

analog input specifications, A-1 to A-6

amplifier characteristics, A-3

dynamic characteristics, A-4

explanation, A-4 to A-6

DAQ rates, A-6

differential nonlinearity, A-5

- dither, A-6
- integral nonlinearity, A-5
- relative accuracy, A-4 to A-5
- system noise, A-5 to A-6
- input characteristics, A-1 to A-2
- transfer characteristics, A-2 to A-3
- analog output circuitry, 4-8 to 4-10
- analog output configuration
 - bit configurations (table), 2-5
 - description, 2-6
 - factory configuration, 2-5
 - unipolar or bipolar output, 2-6
- analog output signal connections
 - digital I/O signal connections, 3-14 to 3-16
 - making connections (figure), 3-14
 - pins for, 3-13
 - Port C pin connections, 3-17
 - timing specifications
 - Mode 1 input timing (figure), 3-19
 - Mode 1 timing for output transfers (figure), 3-20
 - Mode 2 bidirectional timing (figure), 3-21
 - signals for (table), 3-18
- analog output specifications, A-7 to A-8
 - differential nonlinearity, A-8
 - dynamic characteristics, A-8
 - explanation, A-8
 - output characteristics, A-7
 - relative accuracy, A-8
 - transfer characteristics, A-7
 - voltage output, A-7 to A-8
- analog to digital converter (ADC), 4-4

B

- bipolar analog input
 - configuration settings (table), 2-5
 - polarity and range configuration, 2-9
 - signal range versus gain (table), 4-7 to 4-8
- bipolar analog output configuration, 2-6
 - settings (table), 2-5

- bulletin board support, C-1

C

- cables
 - custom, 1-5 to 1-6
 - parallel port, troubleshooting, B-2 to B-3
- Calibrate-1200 function, 5-3
- calibration
 - calibration DACs, 5-1
 - EEPROM storage, 5-1 to 5-2
 - equipment requirements, 5-3
 - factory calibration, 5-2
 - higher gains, 5-2
 - overview, 5-1 to 5-2
 - using Calibrate-1200 function, 5-3
- CLK signal, in general-purpose timing signal
 - connections, 3-26 to 3-29
- CLKB1 signal, 3-4
- CLKB2 signal, 3-4
- common-mode signal rejection, 3-13
- configuration, 2-2 to 2-10. *See also* installation.
 - analog input, 2-6 to 2-9
 - bit configurations (table), 2-5
 - DIFF input, 2-7 (table), 2-8
 - factory configuration, 2-5
 - NRSE input, 2-7 (table), 2-8
 - polarity and range, 2-9
 - RSE input, 2-7 (table), 2-8
 - analog output
 - bit configurations (table), 2-5
 - description, 2-6
 - factory configuration, 2-5
 - hazardous voltage warnings, 2-4 to 2-5
 - parts locator diagram (figure), 2-4
 - SCXI circuitry, 2-9 to 2-10
 - SCXI configurations, 4-17 to 4-18
- CONVERT signal
 - posttrigger DAQ timing (figure)
 - case 1, 3-23
 - case 2, 3-24
 - pretrigger DAQ timing (figure), 3-25

counter block diagram, 4-12
 counter/timer signals. *See* general-purpose timing signal connections and counter/timer signals.
 COUTB1 signal, 2-9
 custom cables, 1-5 to 1-6
 customer communication, *xiii*, C-1 to C-2

D

DAC (digital to analog converter), 4-9
 DAC00OUT signal
 analog output circuitry, 4-9
 analog output signal connections, 3-13 to 3-14
 description (table), 3-3
 DAC10OUT signal
 analog output circuitry, 4-9
 analog output signal connections, 3-13 to 3-14
 description (table), 3-3
 DAQ circuitry, 4-4 to 4-8
 bipolar analog input signal range versus gain (table), 4-7 to 4-8
 block diagram, 4-3
 DAQ rates, 4-6 to 4-8, A-6
 maximum recommended data acquisition rates (table), 4-7
 multiple-channel (scanned) data acquisition, 4-5 to 4-6
 overview, 4-2 to 4-3
 settling time versus gain (table), 4-7
 single-channel data acquisition, 4-5
 timing circuitry, 4-4 to 4-8
 unipolar analog input signal range versus gain (table), 4-8
 DAQ timing connections, 3-22 to 3-26
 EXTCONV* signal timing (figure), 3-22
 EXTUPDATE* signal timing for updating DAC output (figure), 3-26
 posttrigger data acquisition timing
 case 1 (figure), 3-23
 case 2 (figure), 3-24

 pretrigger data acquisition timing (figure), 3-25
 DAQD*/A signal, 3-30
 DATA signal
 description (table), 3-18
 mode 1 input timing (figure), 3-19
 mode 1 output timing (figure), 3-20
 mode 2 bidirectional timing (figure), 3-21
 DGND signal (table), 3-3, 3-4
 differential (DIFF) input configuration
 definition (table), 2-7
 description, 2-8
 differential nonlinearity
 analog input specifications, A-5
 analog output specifications, A-8
 differential signal connections (DIFF configuration), 3-7 to 3-8
 definition, 3-7
 floating signal sources, 3-9 to 3-10
 grounded signal sources, 3-8 to 3-9
 when to use, 3-7
 digital I/O circuitry, 4-10
 digital I/O signal connections, 3-14 to 3-16
 pins for, 3-14
 SCXIBus, 3-30 to 3-31
 specifications and ratings, 3-15
 typical applications (figure), 3-16
 digital I/O specifications, A-8 to A-9
 digital to analog converter (DAC), 4-9
 direct parallel port connection to PC, 2-3
 dither circuitry, A-6
 documentation
 conventions used in manual, *x-xi*
 National Instruments documentation set, *xi-xiii*
 organization of manual, *ix-x*
 related documentation, *xiii*
 dynamic characteristics
 analog input specifications, A-4
 analog output specifications, A-8

E

- e-mail support, C-2
- EEPROM storage of calibration data, 5-1 to 5-2
- electronic support services, C-1 to C-2
- environment specifications, A-11
- event counting, 3-26 to 3-27
 - application with external switch gating (figure), 3-27
- EXTCONV* signal
 - absolute maximum voltage input rating, 3-26
 - DAQ timing connections, 3-22 to 3-23
 - description (table), 3-3
 - posttrigger DAQ timing (figure)
 - case 1, 3-23
 - case 2, 3-24
 - pretrigger DAQ timing (figure), 3-25
 - SCXI configuration, 2-9
 - timing requirements (figure), 3-22
- EXTTRIG signal
 - DAQ timing connections, 3-22 to 3-25
 - description (table), 3-3
 - posttrigger DAQ timing (figure)
 - case 1, 3-23
 - case 2, 3-24
 - pretrigger DAQ timing (figure), 3-25
- EXTUPDATE* signal
 - absolute maximum voltage input rating, 3-26
 - analog output circuitry, 4-9
 - DAQ timing connections, 3-25 to 3-26
 - description (table), 3-3
 - timing for updating DAC output (figure), 3-26

F

- fax and telephone support, C-2
- FaxBack support, C-2
- floating signal sources
 - differential connections, 3-9 to 3-10
 - recommended input configurations

- (figure), 3-7
- requirements, 3-6
- single-ended connections, 3-10
- frequency measurement, 3-28
 - application (figure), 3-28
- front connector. *See* signal connections.
- FTP support, C-1
- fuse, 2-4, A-10

G

- GATB0 signal, 3-3
- GATB1 signal, 3-4
- GATB2 signal, 3-4
- GATE signal, in general-purpose timing
 - signal connections, 3-26 to 3-30
- general-purpose timing signal connections and counter/timer signals, 3-26 to 3-30
 - event counting, 3-26 to 3-27
 - application with external switch gating (figure), 3-27
 - frequency measurement, 3-28
 - application (figure), 3-28
 - general-purpose timing signals (figure), 3-29
 - pulse-width measurement, 3-27
 - specifications and ratings for 82C53 I/O signals, 3-28 to 3-29
 - time-lapse measurement, 3-27
- ground-referenced signal sources
 - description, 3-6
 - differential connections, 3-8 to 3-9
 - recommended input configurations (figure), 3-7
 - single-ended connections, 3-11 to 3-12

H

hardware installation. *See* installation.
 hazardous voltage warnings, 2-4 to 2-5
 HOLDTRIG signal, 3-30
 HWTRIG mode, 3-22 to 3-23

I

IBF signal
 description (table), 3-18
 mode 1 input timing (figure), 3-19
 mode 2 bidirectional timing (figure), 3-21
 input characteristics, analog input
 specifications, A-1 to A-2
 input modes. *See* analog input configuration.
 installation. *See also* configuration.
 hardware installation, 2-1 to 2-2
 troubleshooting, B-1 to B-3
 IRQ level, B-2
 parallel port address, B-1 to B-2
 parallel port cable, B-2 to B-3
 PCMCIA cards, B-2
 unpacking the SCXI-1200, 1-6
 instrumentation amplifier, 2-7, 3-5
 integral nonlinearity, analog input
 specifications, A-5
 interrupts for parallel ports, 2-3, B-2
 interval-scanning timing
 single-channel interval timing (figure),
 4-14
 two-channel interval-scanning timing
 (figure), 4-13
 INTR signal
 description (table), 3-18
 mode 1 input timing (figure), 3-19
 mode 1 output timing (figure), 3-20
 mode 2 bidirectional timing (figure), 3-21

J

jumper settings for SCXI-1200, 2-9 to 2-10

L

LabVIEW and LabWindows/CVI application
 software, 1-3

M

manual. *See* documentation.
 mode 1 input timing (figure), 3-19
 mode 1 timing for output transfers (figure),
 3-20
 mode 2 bidirectional timing (figure), 3-21
 module configuration. *See* configuration.
 multiple-channel (scanned) data acquisition,
 4-5 to 4-6

N

NI-DAQ driver software, 1-3 to 1-4
 noise, system, A-5 to A-6
 nonlinearity
 differential
 analog input specifications, A-5
 analog output specifications, A-8
 integral, A-5
 NRSE (nonreferenced single-ended) input
 configuration
 definition (table), 2-7
 description, 2-8
 single-ended connections for grounded
 signal sources, 3-11 to 3-12

O

OBF* signal
 description (table), 3-18
 mode 1 output timing (figure), 3-20
 mode 2 bidirectional timing (figure), 3-21

operation of SCXI-1200. *See* theory of operation.

OUT signal, in general-purpose signal connections, 3-26 to 3-30

OUTB0 signal, 3-3

OUTB1 signal, 3-4

OUTB2 signal, 3-4

output characteristics, analog output specifications, A-7

P

PA<0..7> signal, 3-3

parallel ports

- IBM-compatible PCs, 2-3

- installation troubleshooting, B-1 to B-3
 - address for parallel port, B-1 to B-2
 - cable problems, B-2 to B-3

- IRQ level, B-2

- PCMCIA cards, B-2

- specifications, A-10

PB<0..7> signal, 3-3

PC<0..7> signal, 3-3

physical specifications, A-11

pin assignments for front connector (figure), 3-2

Port C pin connections, 3-17

- signal assignments (table), 3-17

posttrigger data acquisition timing

- case 1 (figure), 3-23

- case 2 (figure), 3-24

power requirement specifications, A-10

PRETRIG mode, 3-22, 3-24

pretrigger data acquisition timing (figure), 3-25

programmable gain amplifier, 4-4

pulse-width measurement, 3-27

R

RD* signal

- description (table), 3-18

- mode 1 input timing (figure), 3-19

- mode 2 bidirectional timing (figure), 3-21

register-level programming, 1-4 to 1-5

relative accuracy

- analog input specifications, A-4 to A-5

- analog output specifications, A-8

RSE (referenced single-ended) input

- configuration

- definition (table), 2-7

- description, 2-8

- single-ended connections for floating signal sources, 3-10

S

SCANCLK signal

- digital I/O signal connections, 3-30

- multiple-module multiplexed scanning, 4-15 to 4-16

SCANCON signal, multiple-module

- multiplexed scanning, 4-15 to 4-16

scanned (multiple-channel) data acquisition, 4-5 to 4-6

scanning modes, SCXI

- multiple-module multiplexed scanning, 4-15 to 4-18

- single-module parallel scanning, 4-15

SCXI digital interface, 4-14 to 4-18

- block diagram, 4-14

- multiple-module multiplexed scanning, 4-15 to 4-18

- SCXI configurations with SCXI-1200, 4-17 to 4-18

- single-module parallel scanning, 4-15

SCXI-1200

- block diagram, 4-1

- optional equipment, 1-5 to 1-6

- overview and features, 1-1 to 1-2

- requirements for getting started, 1-2

- software programming choices

- LabVIEW and LabWindows/CVI

- application software, 1-3

- NI-DAQ driver software, 1-3 to 1-4

- register-level programming, 1-4 to 1-5
 - unpacking, 1-6
- SCXIbus digital I/O signal connections, 3-30 to 3-31
- SERCLK signal, 3-30
- SERDATOUT signal, 3-30
- signal connections
 - analog input, 3-4 to 3-6
 - analog output, 3-13 to 3-21
 - common-mode signal rejection, 3-13
 - differential connections
 - definition, 3-7
 - floating signal sources, 3-9 to 3-10
 - grounded signal sources, 3-8 to 3-9
 - when to use, 3-6
 - digital I/O signal connections, 3-14 to 3-16
 - floating signal sources, 3-6
 - differential connections, 3-9 to 3-10
 - recommended input configurations (figure), 3-7
 - single-ended connections, 3-10
 - front connector pin assignments (figure), 3-2
 - ground-referenced signal sources, 3-6
 - differential connections, 3-8 to 3-9
 - recommended input configurations (figure), 3-7
 - single-ended connections, 3-11 to 3-12
 - input configurations, 3-7 to 3-13
 - Port C pin connections, 3-17
 - SCXI-1200 instrumentation amplifier, 3-5
 - signal descriptions, 3-2 to 3-4
 - single-ended connections
 - definition, 3-10
 - floating signal sources (RSE configuration), 3-11
 - grounded signal sources (NRSE configuration), 3-11 to 3-12
 - when to use, 3-10
 - timing connections
 - data acquisition, 3-22 to 3-26
 - digital I/O signal connections for SCXIbus, 3-30 to 3-31
 - event counting, 3-26 to 3-27
 - application with external switch gating (figure), 3-27
 - EXTUPDATE* signal timing for updating DAC output (figure), 3-26
 - frequency measurement, 3-28
 - frequency measurement application (figure), 3-28
 - general-purpose timing connections and counter/timer signals, 3-26 to 3-30
 - general-purpose timing signal requirements (figure), 3-29
 - pins for, 3-22
 - posttrigger data acquisition timing
 - case 1 (figure), 3-23
 - case 2 (figure), 3-24
 - pretrigger data acquisition timing (figure), 3-25
 - pulse-width measurement, 3-27
 - specifications and ratings for 82C53 I/O signals, 3-28 to 3-29
 - time-lapse measurement, 3-27
 - timing specifications
 - mode 1 input timing (figure), 3-19
 - mode 1 timing for output transfers (figure), 3-20
 - mode 2 bidirectional timing (figure), 3-21
 - signals for (table), 3-18
 - warning against exceeding maximum ratings, 3-1
- single-channel data acquisition, 4-5
- single-ended signal connections
 - definition, 3-10
 - floating signal sources (RSE configuration), 3-11
 - grounded signal sources (NRSE configuration), 3-11 to 3-12

- when to use, 3-10
- SLOT0SEL* signal, 3-30
- software programming choices
 - LabVIEW and LabWindows/CVI application software, 1-3
 - NI-DAQ driver software, 1-3 to 1-4
 - register-level programming, 1-4 to 1-5
- specifications
 - analog input, A-1 to A-6
 - amplifier characteristics, A-3
 - dynamic characteristics, A-4
 - explanation, A-4 to A-6
 - input characteristics, A-1 to A-2
 - transfer characteristics, A-2 to A-3
 - analog output, A-7 to A-8
 - dynamic characteristics, A-8
 - explanation, A-8
 - output characteristics, A-7
 - transfer characteristics, A-7
 - voltage output, A-7 to A-8
 - digital I/O, A-8 to A-9
 - environment, A-11
 - physical, A-11
 - power requirements, A-10
 - timing I/O, A-9 to A-10
- specifications, timing. *See* timing specifications.
- specifications and ratings
 - 82C53 I/O signals, 3-28 to 3-29
 - digital I/O signal connections, 3-15
- STB* signal
 - description (table), 3-18
 - mode 1 input timing (figure), 3-19
 - mode 2 bidirectional timing (figure), 3-21
- system noise, A-5 to A-6

T

- technical support, C-1 to C-2
- theory of operation
 - analog input and DAQ circuitry
 - bipolar analog input signal range versus gain (table), 4-7 to 4-8

- DAQ rates, 4-6 to 4-8
 - description, 4-3 to 4-4
 - maximum recommended data acquisition rates (table), 4-7
 - overview, 4-2 to 4-3
 - unipolar analog input signal range versus gain (table), 4-8
- analog input and data acquisition circuitry
 - block diagram, 4-3
 - DAQ timing circuitry, 4-4 to 4-8
 - multiple-channel (scanned) data acquisition, 4-5 to 4-6
 - settling time versus gain (table), 4-7
 - single-channel data acquisition, 4-5
- analog output circuitry, 4-8 to 4-10
- digital I/O circuitry, 4-10
- functional overview, 4-1 to 4-2
- SCXI digital interface, 4-14 to 4-18
 - block diagram, 4-14
 - multiple-module multiplexed scanning, 4-15 to 4-18
 - SCXI configurations with SCXI-1200, 4-17 to 4-18
 - single-module parallel scanning, 4-15
- SCXI-1200 block diagram, 4-1
- timing I/O circuitry, 4-11 to 4-14
 - block diagram, 4-12
 - counter block diagram, 4-12
 - single-channel interval timing (figure), 4-14
 - two-channel interval-scanning timing (figure), 4-13
- time-lapse measurement, 3-27
- timing connections
 - DAQ timing connections, 3-22 to 3-26
 - EXTCONV* signal timing (figure), 3-22
 - EXTUPDATE* signal timing for updating DAC output (figure), 3-26
 - posttrigger data acquisition timing
 - case 1 (figure), 3-23
 - case 2 (figure), 3-24

- pretrigger data acquisition timing (figure), 3-25
- digital I/O signal connections for SCXIBus, 3-30 to 3-31
- general-purpose signals and counter/timer signals, 3-26 to 3-30
 - event counting, 3-26 to 3-27
 - event counting application with external switch gating (figure), 3-27
 - frequency measurement, 3-28
 - frequency measurement application (figure), 3-28
 - pulse-width measurement, 3-27
 - specifications and ratings for 8253 I/O signals, 3-28 to 3-29
 - time-lapse measurement, 3-27
 - timing requirements (figure), 3-29
- pins for, 3-22
- timing I/O circuitry, 4-11 to 4-14
 - block diagram, 4-12
 - counter block diagram, 4-12
 - single-channel interval timing (figure), 4-14
 - specifications, A-9 to A-10
 - two-channel interval-scanning timing (figure), 4-13
- timing specifications
 - Mode 1 input timing (figure), 3-19
 - Mode 1 timing for output transfers (figure), 3-20
 - Mode 2 bidirectional timing (figure), 3-21
 - signals for (table), 3-18
- transfer characteristics
 - analog input specifications, A-2 to A-3
 - analog output specifications, A-7
- TRIG0 signal, multiple-module multiplexed scanning, 4-15 to 4-16

U

- unipolar analog input
 - polarity and range configuration, 2-9

- signal range versus gain (table), 4-8
- unipolar analog output configuration, 2-6
- unpacking the SCXI-1200, 1-6

V

- voltage output specifications, A-7 to A-8

W

- WR* signal
 - description (table), 3-14
 - mode 1 output timing (figure), 3-20
 - mode 2 bidirectional timing (figure), 3-21