

## COMPREHENSIVE SERVICES

We offer competitive repair and calibration services, as well as easily accessible documentation and free downloadable resources.

## SELL YOUR SURPLUS

We buy new, used, decommissioned, and surplus parts from every NI series. We work out the best solution to suit your individual needs.

 Sell For Cash    Get Credit    Receive a Trade-In Deal

## OBSOLETE NI HARDWARE IN STOCK & READY TO SHIP

We stock **New**, **New Surplus**, **Refurbished**, and **Reconditioned** NI Hardware.



*Bridging the gap between the manufacturer and your legacy test system.*

 1-800-915-6216

 [www.apexwaves.com](http://www.apexwaves.com)

 [sales@apexwaves.com](mailto:sales@apexwaves.com)

*All trademarks, brands, and brand names are the property of their respective owners.*

**Request a Quote**

 **CLICK HERE**

**NB-MIO-16**

# **NB-DMA2800**

## **User Manual**

*Block-Mode and GPIB Interface Board  
for Macintosh NuBus Computers*

**November 1995 Edition**

**Part Number 320240B-01**

**© Copyright 1990, 1995 National Instruments Corporation.  
All Rights Reserved.**

**National Instruments Corporate Headquarters**

6504 Bridge Point Parkway

Austin, TX 78730-5039

(512) 794-0100

Technical support fax: (800) 328-2203

(512) 794-5678

**Branch Offices:**

Australia 03 9 879 9422, Austria 0662 45 79 90 0, Belgium 02 757 00 20, Canada (Ontario) 519 622 9310,

Canada (Québec) 514 694 8521, Denmark 45 76 26 00, Finland 90 527 2321, France 1 48 14 24 24,

Germany 089 741 31 30, Hong Kong 2645 3186, Italy 02 48301892, Japan 03 5472 2970, Korea 02 596 7456,

Mexico 95 800 010 0793, Netherlands 0348 433466, Norway 32 84 84 00, Singapore 2265886, Spain 91 640 0085,

Sweden 08 730 49 70, Switzerland 056 20 51 51, Taiwan 02 377 1200, U.K. 01635 523545

## **Limited Warranty**

The NB-DMA2800 is warranted against defects in materials and workmanship for a period of one year from the date of shipment, as evidenced by receipts or other documentation. National Instruments will, at its option, repair or replace equipment that proves to be defective during the warranty period. This warranty includes parts and labor.

The media on which you receive National Instruments software are warranted not to fail to execute programming instructions, due to defects in materials and workmanship, for a period of 90 days from date of shipment, as evidenced by receipts or other documentation. National Instruments will, at its option, repair or replace software media that do not execute programming instructions if National Instruments receives notice of such defects during the warranty period. National Instruments does not warrant that the operation of the software shall be uninterrupted or error free.

A Return Material Authorization (RMA) number must be obtained from the factory and clearly marked on the outside of the package before any equipment will be accepted for warranty work. National Instruments will pay the shipping costs of returning to the owner parts which are covered by warranty.

National Instruments believes that the information in this manual is accurate. The document has been carefully reviewed for technical accuracy. In the event that technical or typographical errors exist, National Instruments reserves the right to make changes to subsequent editions of this document without prior notice to holders of this edition. The reader should consult National Instruments if errors are suspected. In no event shall National Instruments be liable for any damages arising out of or related to this document or the information contained in it.

EXCEPT AS SPECIFIED HEREIN, NATIONAL INSTRUMENTS MAKES NO WARRANTIES, EXPRESS OR IMPLIED, AND SPECIFICALLY DISCLAIMS ANY WARRANTY OF MERCHANTABILITY OR FITNESS FOR A PARTICULAR PURPOSE. CUSTOMER'S RIGHT TO RECOVER DAMAGES CAUSED BY FAULT OR NEGLIGENCE ON THE PART OF NATIONAL INSTRUMENTS SHALL BE LIMITED TO THE AMOUNT THERETOFORE PAID BY THE CUSTOMER. NATIONAL INSTRUMENTS WILL NOT BE LIABLE FOR DAMAGES RESULTING FROM LOSS OF DATA, PROFITS, USE OF PRODUCTS, OR INCIDENTAL OR CONSEQUENTIAL DAMAGES, EVEN IF ADVISED OF THE POSSIBILITY THEREOF. This limitation of the liability of National Instruments will apply regardless of the form of action, whether in contract or tort, including negligence. Any action against National Instruments must be brought within one year after the cause of action accrues. National Instruments shall not be liable for any delay in performance due to causes beyond its reasonable control. The warranty provided herein does not cover damages, defects, malfunctions, or service failures caused by owner's failure to follow the National Instruments installation, operation, or maintenance instructions; owner's modification of the product; owner's abuse, misuse, or negligent acts; and power failure or surges, fire, flood, accident, actions of third parties, or other events outside reasonable control.

## **Copyright**

Under the copyright laws, this publication may not be reproduced or transmitted in any form, electronic or mechanical, including photocopying, recording, storing in an information retrieval system, or translating, in whole or in part, without the prior written consent of National Instruments Corporation.

## **Trademarks**

LabVIEW<sup>®</sup>, NI-488<sup>®</sup>, NI-DAQ<sup>®</sup>, RTSI<sup>®</sup>, and Turbo488<sup>™</sup> are trademarks of National Instruments Corporation.

Product and company names listed are trademarks or trade names of their respective companies.

## **WARNING REGARDING MEDICAL AND CLINICAL USE OF NATIONAL INSTRUMENTS PRODUCTS**

National Instruments products are not designed with components and testing intended to ensure a level of reliability suitable for use in treatment and diagnosis of humans. Applications of National Instruments products involving medical or clinical treatment can create a potential for accidental injury caused by product failure, or by errors on the part of the user or application designer. Any use or application of National Instruments products for or involving medical or clinical treatment must be performed by properly trained and qualified medical personnel, and all traditional medical safeguards, equipment, and procedures that are appropriate in the particular situation to prevent serious injury or death should always continue to be used when National Instruments products are being used. National Instruments products are NOT intended to be a substitute for any form of established process, procedure, or equipment used to monitor or safeguard human health and safety in medical or clinical treatment.

# FCC/DOC Radio Frequency Interference Compliance

This equipment generates and uses radio frequency energy and, if not installed and used in strict accordance with the instructions in this manual, may cause interference to radio and television reception. This equipment has been tested and found to comply with the following two regulatory agencies:

## Federal Communications Commission

This device complies with Part 15 of the Federal Communications Commission (FCC) Rules for a Class B digital device. A Class B device is distinguishable from a Class A device by the appearance of an FCC ID number located on the Class B device.

## Canadian Department of Communications

This device complies with the limits for radio noise emissions from digital apparatus set out in the Radio Interference Regulations of the Canadian Department of Communications (DOC).

Le présent appareil numérique n'émet pas de bruits radioélectriques dépassant les limites applicables aux appareils numériques de classe B prescrites dans le règlement sur le brouillage radioélectrique édicté par le ministère des communications du Canada.

## Instructions to Users

These regulations are designed to provide reasonable protection against interference from the equipment to radio and television reception in residential areas.

There is no guarantee that interference will not occur in a particular installation. However, the chances of interference are much less if the equipment is installed and used according to this instruction manual.

If the equipment does cause interference to radio or television reception, which can be determined by turning the equipment on and off, one or more of the following suggestions may reduce or eliminate the problem.

- Operate the equipment and the receiver on different branches of your AC electrical system.
- Move the equipment away from the receiver with which it is interfering.
- Reorient or relocate the receiver's antenna.
- Be sure that the equipment is plugged into a grounded outlet and that the grounding has not been defeated with a cheater plug.

**Notice to user:** Changes or modifications not expressly approved by National Instruments could void the user's authority to operate the equipment under the FCC Rules.

If necessary, consult National Instruments or an experienced radio/television technician for additional suggestions. The following booklet prepared by the FCC may also be helpful: *How to Identify and Resolve Radio-TV Interference Problems*. This booklet is available from the U.S. Government Printing Office, Washington, DC 20402, Stock Number 004-000-00345-4.

# Contents

---

<b>About This Manual</b> .....	xi
Organization of This Manual.....	xii
Conventions Used in This Manual.....	xii
Related Documentation .....	xii
Customer Communication .....	xii
<b>Chapter 1</b>	
<b>Introduction</b> .....	1-1
Overview.....	1-1
What You Need to Get Started.....	1-2
Optional Software.....	1-2
Optional Equipment .....	1-3
Unpacking .....	1-3
<b>Chapter 2</b>	
<b>Installation</b> .....	2-1
Hardware Installation.....	2-1
Cable Connection.....	2-1
<b>Chapter 3</b>	
<b>Theory of Operation</b> .....	3-1
Functional Overview.....	3-1
NuBus Slave Interface Circuitry.....	3-2
DMA and NuBus Master Circuitry.....	3-3
GPIB Interface Circuitry.....	3-4
Timer and RTSI Bus Interface Circuitry.....	3-5
<b>Chapter 4</b>	
<b>Programming</b> .....	4-1
Register Access.....	4-1
Slot Address Space.....	4-1
Register Maps .....	4-2
Register Word Sizes.....	4-7
Register Description.....	4-8
Register Description Format.....	4-8
Configuration Register Group.....	4-9
Board Control Register .....	4-10
Scan Circuitry Bypass Register.....	4-12
EOP Interrupt Enable Register.....	4-13
NuBus Block Mode Enable Register .....	4-14
NuBus Flyby Enable Register.....	4-15
NuBus MLock Enable Register .....	4-16
RTSI Switch Register Group .....	4-17
RTSI Switch Shift Registers .....	4-18
RTSI Switch Strobe Registers.....	4-19
GPIB Register Group.....	4-20
GPIB Monitor Register.....	4-21
The Configuration EPROM .....	4-22

Programming Considerations.....	4-23
Register Programming Considerations .....	4-23
Initializing the NB-DMA2800 Board .....	4-23
Bus Error Handler Installation and Programming Considerations .....	4-23
NB-DMA2800 Programming Components .....	4-24
DMA Interface Programming Considerations .....	4-24
DMA Request Sources.....	4-24
DMA Transfer Modes.....	4-24
Fetch-and-Deposit (Two-Cycle) Single-Transfer Mode .....	4-25
Fetch-and-Deposit (Two-Cycle) Demand Mode .....	4-25
NuBus Flyby (Single-Cycle) Single-Transfer Mode ....	4-26
NuBus Flyby (Single-Cycle) Demand Mode.....	4-26
NuBus Block Mode.....	4-27
Programming Single-Channel DMA Operations.....	4-27
DMA Controller Setup.....	4-27
DMA Transfer Operation.....	4-28
DMA Termination.....	4-28
Programming Multiple-Channel DMA Operations .....	4-29
RTSI Bus Trigger Interface Programming Considerations.....	4-33
RTSI Bus Interrupt Interface Programming Considerations.....	4-37
GPIB Interface Programming Considerations .....	4-37
System Timing Controller Interface Programming Considerations .....	4-38
 <b>Appendix A</b>	
<b>Specifications</b> .....	A-1
 <b>Appendix B</b>	
<b>I/O Connector Pinouts</b> .....	B-1
 <b>Appendix C</b>	
<b>AMD Data Sheet</b> .....	C-1
 <b>Appendix D</b>	
<b>Intel Data Sheet</b> .....	D-1
 <b>Appendix E</b>	
<b>Customer Communication</b> .....	E-1
 <b>Glossary</b> .....	Glossary-1
 <b>Index</b> .....	Index-1



## Figures

Figure 2-1.	GPIB Cable Connected to an NB-DMA2800 .....	2-2
Figure 3-1.	NB-DMA2800 Block Diagram .....	3-1
Figure 3-2.	NuBus Slave Interface Circuitry Block Diagram.....	3-2
Figure 3-3.	DMA and NuBus Master Circuitry Block Diagram.....	3-3
Figure 3-4.	GPIB Interface Circuitry Block Diagram.....	3-4
Figure 3-5.	Am9513A Timer and RTSI Interface.....	3-5
Figure 4-1.	Scan Circuitry.....	4-29
Figure 4-2.	The RTSI Switch 1 Trigger Lines .....	4-35
Figure 4-3.	Gating B<5> onto A<3> .....	4-35
Figure 4-4.	Data Used to Configure the RTSI Trigger Lines .....	4-36
Figure 4-5.	System Timing Controller Configuration.....	4-39
Figure B-1.	GPIB Connector .....	B-1
Figure B-2.	NuBus Pin Assignments.....	B-2
Figure B-3.	RTSI Bus Connector Pinout.....	B-3

## Tables

Table 4-1.	Macintosh Slot Addresses .....	4-1
Table 4-2.	Register Map for the NB-DMA2800 Register Groups .....	4-2
Table 4-3.	Register Map for the GPIB Interface Register Group.....	4-3
Table 4-4.	Register Map for the 82380 Register Group .....	4-4
Table 4-5.	Scan Circuitry for 82380 DMAC .....	4-30
Table 4-6.	Legal Scan Modes–COMMAND<1..0> = 00 .....	4-31
Table 4-7.	RTSI Switch Signals .....	4-34
Table 4-8.	82380 External Interrupt Sources.....	4-37

# About This Manual

---

The NB-DMA2800 is a block-mode direct memory access (DMA) and GPIB interface board for Macintosh NuBus computers. Other National Instruments NB Series boards are serviced by the NB-DMA2800 so that acquired data is transferred directly to memory. The NB-DMA2800 also contains a high-performance NuBus to GPIB interface, enabling data transfers between the Macintosh and thousands of IEEE 488-compatible instruments.

## Organization of This Manual

This manual describes the mechanical and electrical aspects of the NB-DMA2800 and contains information concerning its operation and programming. The manual is divided into the following chapters and appendices:

Chapter 1, *Introduction*, describes the NB-DMA2800, lists what you need to get started, describes the available software packages, lists optional equipment, and explains how to unpack the NB-DMA2800.

Chapter 2, *Installation*, contains instructions for installing the NB-DMA2800 and connecting cables.

Chapter 3, *Theory of Operation*, contains a functional overview of the NB-DMA2800 board and explains the operation of each functional unit making up the NB-DMA2800.

Chapter 4, *Programming*, describes in detail the address and function of each of the NB-DMA2800 control and status registers. This chapter also includes important information about programming the NB-DMA2800.

Appendix A, *Specifications*, lists specifications of the NB-DMA2800.

Appendix B, *I/O Connector Pinouts*, shows the pinouts and signal names of the input/output (I/O) connectors on the NB-DMA2800.

Appendix C, *AMD Data Sheet*, contains the manufacturer data sheet for the Am9513A/Am9513 System Timing Controller (Advanced Micro Devices, Inc.) integrated circuit. This circuit is used on the NB-DMA2800.

Appendix D, *Intel Data Sheet*, contains the *82380 High Performance 32-Bit DMA Controller with Integrated System Support Peripherals* (Intel Corporation) data sheet. This device is used on the NB-DMA2800.

Appendix E, *Customer Communication*, contains forms you can use to request help from National Instruments or to comment on our products.

*Glossary* contains an alphabetical list of acronyms and abbreviations used in this manual.

*Index* alphabetically lists topics covered in this manual, including the page where the topic can be found.

## Conventions Used in This Manual

The following conventions are used in this manual:

<i>italic</i>	Italic text denotes emphasis, a cross reference, or an introduction to a key concept.
monospace	Lowercase text in this font denotes text or characters that are to be literally input from the keyboard, sections of code, programming examples, and syntax examples. This font is also used for the proper names of disk drives, paths, directories, programs, subprograms, subroutines, device names, functions, variables, filenames, and extensions, and for statements and comments taken from program code.
Macintosh	Macintosh refers to all Macintosh II and Macintosh Quadra computers unless otherwise noted.

## Related Documentation

The following documents contain information that may be helpful as you read this manual:

- The Macintosh II or Quadra *Owner's Manual*, *Getting Started* manual, or *Setting Up* manual
- NEC Electronics Inc. 1987 Data Book *Microcomputer Products*

## Customer Communication

National Instruments wants to receive your comments on our products and manuals. We are interested in the applications you develop with our products, and we want to help if you have problems with them. To make it easy for you to contact us, this manual contains comment and configuration forms for you to complete. These forms are in Appendix E, *Customer Communication*.

# Chapter 1

## Introduction

---

This chapter describes the NB-DMA2800, lists the contents of your NB-DMA2800 kit, describes the software packages available for the NB-DMA2800, lists the optional equipment for the NB-DMA2800, and explains how to unpack the NB-DMA2800.

### Overview

The NB-DMA2800 is a 32-bit DMA controller board for Macintosh NuBus computers with NuBus (NB) block-mode master capability. It can be used for high-performance direct memory access (DMA) service to other National Instruments NB Series boards. The NB-DMA2800 uses Real-Time System Integration (RTSI) bus timing and interrupt support to integrate and optimize the operations of the NB boards. Used alone or with other NB Series boards, the NB-DMA2800 offers a high-performance NuBus-to-GPIB interface, enabling data transfers between the Macintosh and thousands of IEEE 488-compatible instruments. By itself, the NB-DMA2800 converts the Macintosh into one of the highest performance GPIB controllers available. The NB DMA2800 transfers rates of data up to 1 Mbytes/sec, so it can be used with the fastest IEEE 488 instruments in a wide variety of test, measurement, monitoring, and control applications.

The combination of the Macintosh, NB Series data acquisition boards, and the NB-DMA2800 introduces the next generation of high-performance personal computers for scientific and engineering applications. High-speed DMA and the tightly integrated timing offered by the RTSI bus are features unprecedented in personal computers. These hardware features merge with the LabVIEW software system to create a new integrated instrumentation platform that makes rapid development of high-performance test and measurement systems possible.

The NB-DMA2800 contains a high-performance GPIB interface. The National Instruments Turbo488 custom-integrated circuit combined with the NEC  $\mu$ PD7210 offers complete IEEE 488 talker/listener/controller (TLC) capability; a first-in-first-out (FIFO) data buffer with enhanced throughput including 1 Mbytes/sec GPIB reads, 700 kbytes/sec GPIB writes, and 320 kbytes/sec GPIB commands; automatic hardware handling of last-byte operations; terminal count interrupt synchronized with GPIB handshaking; GPIB command transferral under DMA control; and an extra GPIB monitor and control port for board and bus level diagnostics.

The Intel 82380 DMA controller offers eight 32-bit DMA channels. The controller handles 8-bit, 16-bit, and 32-bit devices and automatically packs or unpacks data as required. The NB-DMA2800 uses programmed logic array (PLA) technology to add multichannel scanning features to the DMA interface. Using these features, other members of the NB Series can transfer data to and from multiple buffers with no loss of efficiency. The NB-DMA2800 also offers DMA flyby mode for input/output (I/O) boards that can be used for DMA flyby mode and NuBus block mode for I/O and memory boards that can be used for NuBus block mode.

The NB-DMA2800 also includes an Am9513A five-channel System Timing Controller unit for precise system timing with clock periods as low as 200 nsec. Three timer outputs can generate DMA requests for precise timing of DMA transfer activity. Thus, the Am9513A offers the accurate sample timing essential in a data acquisition system. The timer can also send signals to other NB Series boards via RTSI bus lines.

The NB-DMA2800 contains board-to-board trigger signal routing hardware. The RTSI switch is a custom-integrated circuit developed by National Instruments that interfaces between the RTSI bus and the System Timing Controller unit. The RTSI switch uses a crossbar switch to move any input from the counter/timer to any of seven RTSI bus lines under software control. The System Timing Controller can then communicate with other NB boards across the RTSI bus.

## What You Need to Get Started

To set up and use your NB-DMA2800, you will need the following:

- NB-DMA2800 board
- NB-DMA2800 User Manual*
- NI-488.2 Macintosh OS software package, with manual and 2 disks
- NI-488.2 Macintosh OS Software Reference Manual*

Your NB-DMA2800 is shipped with NI-488.2 Macintosh OS. NI-488.2 is a comprehensive package of programs and drivers that transform the Macintosh into a GPIB controller with complete communications and bus management capability. The NI-488.2 package contains language interfaces for Microsoft QuickBASIC, Macintosh Programmer's Workshop (MPW) C, THINK C, HyperTalk, and Device Manager.

## Optional Software

The NB-DMA2800 can be used with the NI-DAQ software for Macintosh. NI-DAQ has a library of functions that can be called from your application programming environment. These functions include routines for analog input (A/D conversion), buffered data acquisition (high-speed A/D conversion), analog output (D/A conversion), waveform generation, digital I/O, counter/timer, SCXI, RTSI, and self-calibration. NI-DAQ maintains a consistent software interface among its different versions so you can switch between platforms with minimal modifications to your code. NI-DAQ comes with language interfaces for MPW C, THINK C, Pascal, and Microsoft QuickBASIC. Any language that uses Device Manager Toolbox calls can access NI-DAQ.

The NB-DMA2800 can also be used with LabVIEW 2, a software system that features interactive graphics, a state-of-the-art user interface, and a powerful graphical programming language. The LabVIEW 2 Data Acquisition VI Library, a series of VIs for using LabVIEW 2 with the Lab-LC and other National Instruments boards, is included with LabVIEW 2. The LabVIEW 2 Data Acquisition VI Library is functionally equivalent to the NI-DAQ software for Macintosh.

## Optional Equipment

National Instruments offers four different ribbon cables which can be used to connect the RTSI connectors of multiple NB Series boards. The RTSI cables are 50-conductor cables with two, three, four, or five 50-position connectors which mate with the RTSI connectors of the NB Series boards.

## Unpacking

Your NB-DMA2800 board is shipped in an antistatic plastic bag to prevent electrostatic damage to the board. Several components on the board may be damaged by electrostatic discharge. To avoid such damage in handling the board, take the following precautions:

- Touch the plastic bag to a metal part of your computer before removing the board from the bag.
- Remove the board from the bag and inspect the board for loose components or any other sign of damage. Notify National Instruments if the board appears damaged in any way. Do *not* install a damaged board into your computer.

# Chapter 2

## Installation

---

This chapter contains instructions for installing the NB-DMA2800 and connecting cables.

### Hardware Installation

Within the manual shipped with your Macintosh computer, read the instructions for installing the video card in the main unit. You can use these instructions as a universal board installation guide.

Read the entire installation procedure before installing the NB-DMA2800 into the Macintosh. However, if you are using the NB-DMA2800 with other NB Series boards, keep in mind that all NB Series boards should reside in adjacent slots because the Real-Time System Integration (RTSI) bus cable must connect them together. Once installed, the operating system finds the board when you turn on your computer.

### Cable Connection

When using the NB-DMA2800 with other NB Series boards, connect the RTSI bus cable to each board before closing the computer chassis. Plug the RTSI cable into each NB Series board. Hold the end of the board when connecting the RTSI connector because there is no support under the board. RTSI bus cables of various lengths are available from National Instruments. RTSI cable connectors can be left free if there are more connectors than NB Series boards.

When using the NB-DMA2800 as a GPIB interface, install the GPIB extension connector before attaching the GPIB cable to the NB-DMA2800. Push the extension connector into the NB-DMA2800 connector and tighten the thumb screws on each side of the extension connector. Finally, attach one end of the GPIB cable to the extension connector and tighten the thumb screws on both sides of the GPIB connector. Figure 2-1 illustrates the connection.

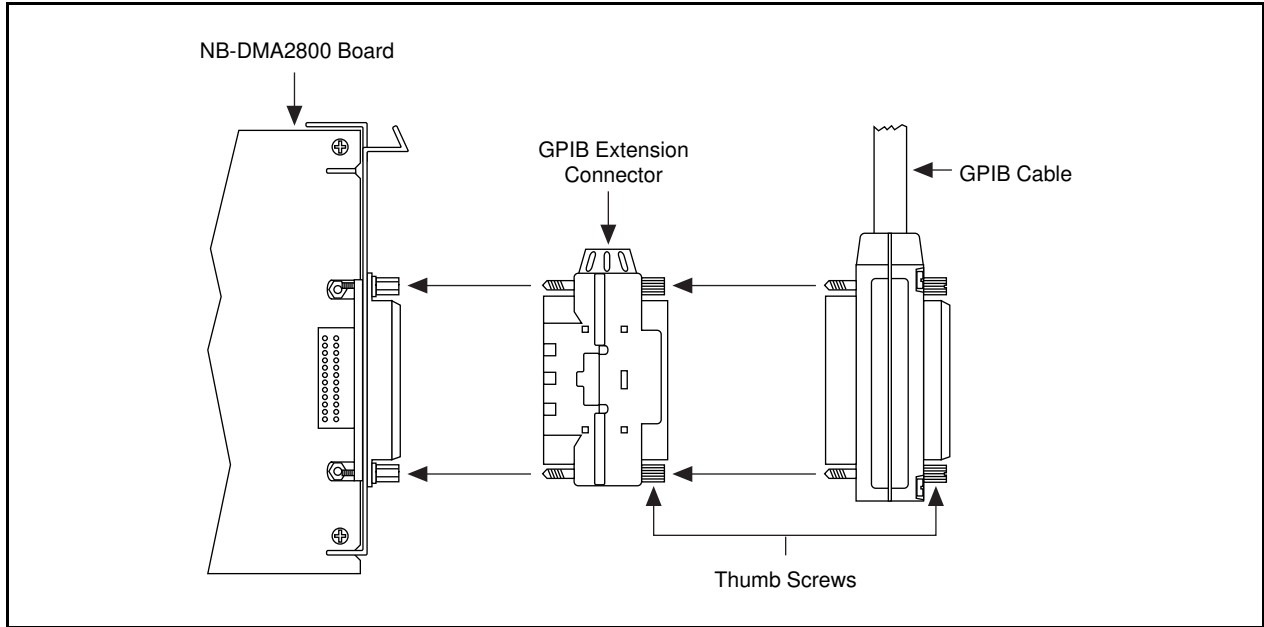

Figure 2-1. GPIB Cable Connected to an NB-DMA2800

When the NB-DMA2800 installation is complete, the GPIB cable is ready to attach to a GPIB device.



# Chapter 3

## Theory of Operation

This chapter gives a functional overview of the NB-DMA2800 board and explains the operation of each functional unit making up the NB-DMA2800.

### Functional Overview

The major components making up the NB-DMA2800 board are as follows:

- NuBus slave interface circuitry
- DMA and NuBus master interface circuitry
- GPIB interface circuitry
- Timer and RTSI bus interface circuitry

The internal data and control buses interconnect the components. The theory of operation of each of these components is explained in the remainder of this chapter. Figure 3-1 is a block diagram of the NB-DMA2800.

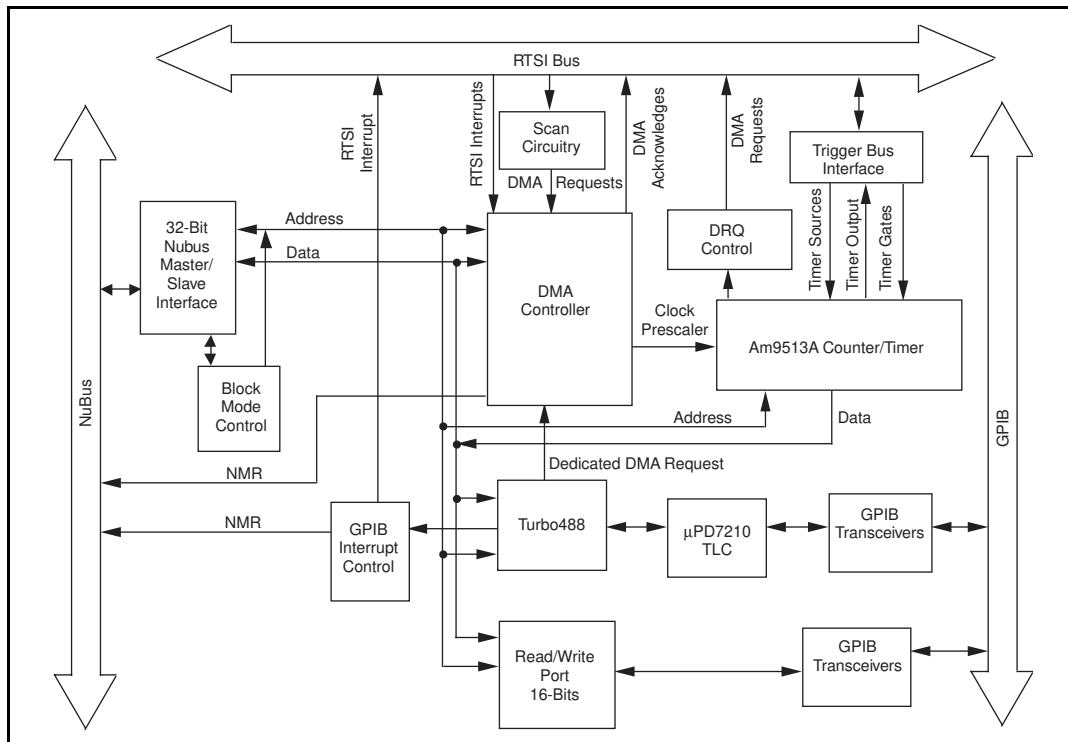

Figure 3-1. NB-DMA2800 Block Diagram

### NuBus Slave Interface Circuitry

The NB-DMA2800 functions as a 32-bit NuBus slave board. The NuBus is a 32-bit address and data bus with a 10-MHz clock. In addition, the NuBus contains interface signals for read and write operations, and an interrupt line that can be driven by boards in NuBus slots. The components making up the NB-DMA2800 NuBus slave interface circuitry are shown in Figure 3-2.

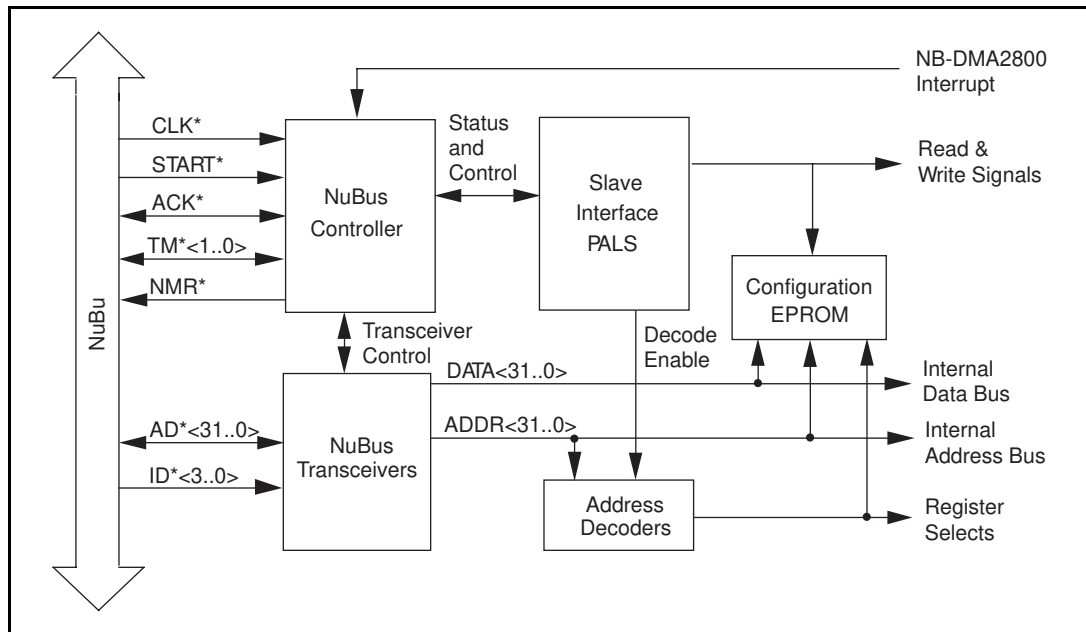

Figure 3-2. NuBus Slave Interface Circuitry Block Diagram

The NuBus interface circuitry consists of the Texas Instruments NuBus interface chip-set, address decoder circuitry, EPROM, and NuBus non-master request (NMR) interrupt circuitry. This interface circuitry generates the signals necessary to control and monitor the operation of the NB-DMA2800 circuitry.

The NuBus interface chips on the NB-DMA2800 match NuBus address lines 27 through 24 to the slot ID lines supplied by the slot that the board is plugged into. The board can then determine when the slot that it occupies is being addressed. Each slot in the Macintosh has a unique slot address. The address latches on the NB-DMA2800 latch all of the address lines from the NuBus. Address lines 17 through 19 are decoded by the NB-DMA2800 address decoding circuitry to generate selects for the onboard configuration ROM and other registers on the board. Address lines 20 through 23 are left undecoded by the NB-DMA2800 board. The NB-DMA2800 can then be compatible with both the 24-bit and 32-bit bus modes used by the Macintosh.

The NB-DMA2800 is a 32-bit slave and can use all 32 NuBus data lines. The NuBus interface timing signals are decoded by the interface chips that generate the proper read and write signals for the remaining NB-DMA2800 circuitry. The NuBus 10-MHz clock is used to synchronize the NuBus interface timing circuitry.

The configuration ROM is an 8-kbyte EPROM that contains information related to the NB-DMA2800 board. This ROM is read by the Macintosh Slot Manager upon system startup. This configuration ROM is required by the NuBus so the Macintosh operating system and other software can identify the board.

The NB-DMA2800 is able to cause interrupts in the Macintosh by driving the NMR interrupt line.

**Note:** *While the DMA controller (DMAC) controls the local bus, no other NuBus master can access the NB-DMA2800. If the NB-DMA2800 is addressed as a NuBus slave after the 82380 DMAC has been given the local bus on the board, the NB-DMA2800 issues a NuBus RETRY error. In general, this tells any board capable of becoming a master in the Macintosh NuBus that the slave access to the NB-DMA2800 needs to be tried again. However, the Macintosh generates a 68020 bus error when a NuBus RETRY occurs. For this reason, a bus error handler must be installed in order to operate the NB-DMA2800. This is not a problem if the National Instruments driver, which comes with the NB-DMA2800, is installed. However, if you attempt to write your own driver software for the NB-DMA2800, you must be aware of this situation and have some sort of bus error handler installed. See Chapter 4, Programming, for more information on installing and programming a bus error handler.*

## DMA and NuBus Master

The DMA circuit controls the flow of data between peripherals and memory. The NuBus interface chips accept signals from the DMA controller and perform appropriate NuBus master operations, such as arbitrations, reads, and writes. Figure 3-3 shows a block diagram of the DMA and NuBus master logic.

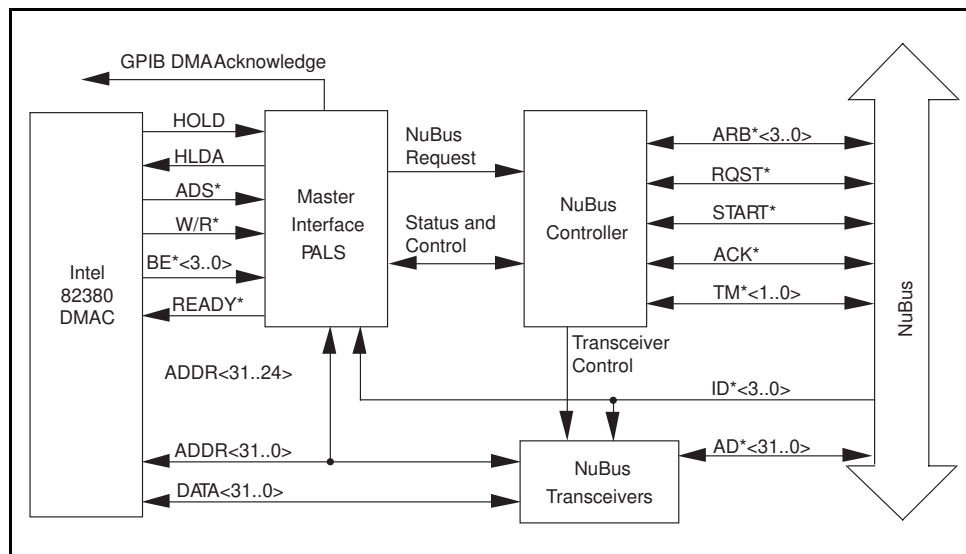

Figure 3-3. DMA and NuBus Master Circuitry Block Diagram

When the DMA controller is ready to read or write data, it asserts hold request (HOLD). Then, the interface circuitry grants the DMA controller the local bus by asserting hold acknowledge (HLDA) and the DMA controller, sensing the assertion of HLDA, begins its bus operations. If the interface circuitry determines that the DMA controller is addressing memory or I/O in an address space other than that of the NB-DMA2800, the interface chips perform the NuBus arbitration sequence in accordance with the NuBus specification. If the interface circuitry determines that the DMA controller is addressing memory or I/O in the address space of the NB-DMA2800, the DMA transaction takes place with the Turbo488 instead of going out over the NuBus.

When the DMA controller has completed all pending transactions, it releases HOLD. The interface circuitry senses the release, negates HLDA, and releases the local bus to any other master that may want access to it.

## GPIB Interface Circuitry

The NB-DMA2800 offers a high-speed IEEE 488 (GPIB) interface. The Turbo488 enhances the NEC  $\mu$ PD7210 for a complete talker/listener/controller (TLC) interface capable of data transfer rates as high as 1 Mbytes/sec. Figure 3-4 shows a block diagram of the GPIB interface logic.

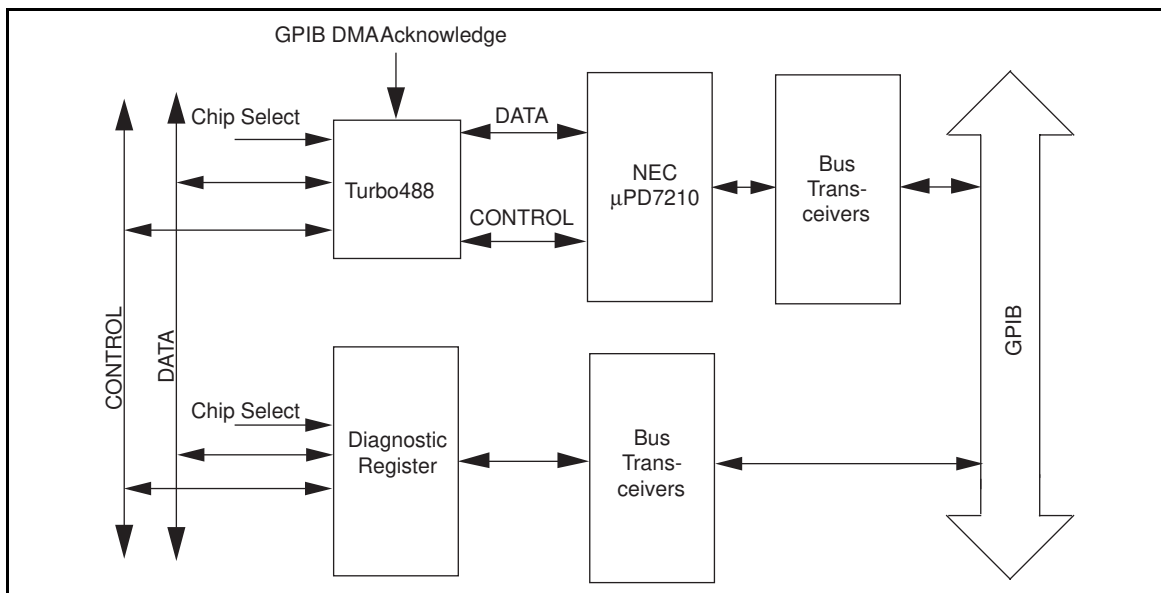

Figure 3-4. GPIB Interface Circuitry Block Diagram

The Turbo488 responds to 8-bit or 16-bit read and write operations. When the proper address appears on the NuBus, or when the DMAC generates a DMA acknowledge inside the NB-DMA2800 address space, the Turbo488 interface logic generates a chip select or DMA acknowledge that activates the Turbo488. The Turbo488, if necessary, performs data or control accesses to the  $\mu$ PD7210 to carry out the desired function.

The NB-DMA2800 has specialized hardware for monitoring and controlling GPIB activity independent of the  $\mu$ PD7210 interface. The complete GPIB status can be read using this circuitry, and any line can be driven at any time. This is used to synchronize GPIB activity and to simplify software. Comprehensive hardware diagnostics can also be performed without the use of a special loop-back connector.

## Timer and RTSI Bus Interface Circuitry

DMA requests and interrupts from other NB Series boards can be received by the 82380 via the NB-DMA2800 bus interface. The Am9513A receives its master clock from the TOUT1\* output of the Intel 82380. Each of the Am9513A outputs is tied to one of the RTSI switches so that the NB-DMA2800 can distribute timing signals across the system. Also, the Am9513A source and gate inputs are connected to a RTSI switch so the NB-DMA2800 can use timing signals generated elsewhere in the system. Three of the Am9513A outputs can be used to generate constant DMA requests on the RTSI bus DMA request lines. Figure 3-5 shows a block diagram of the Am9513A Timer/Counter Unit, 82380 and RTSI switches.

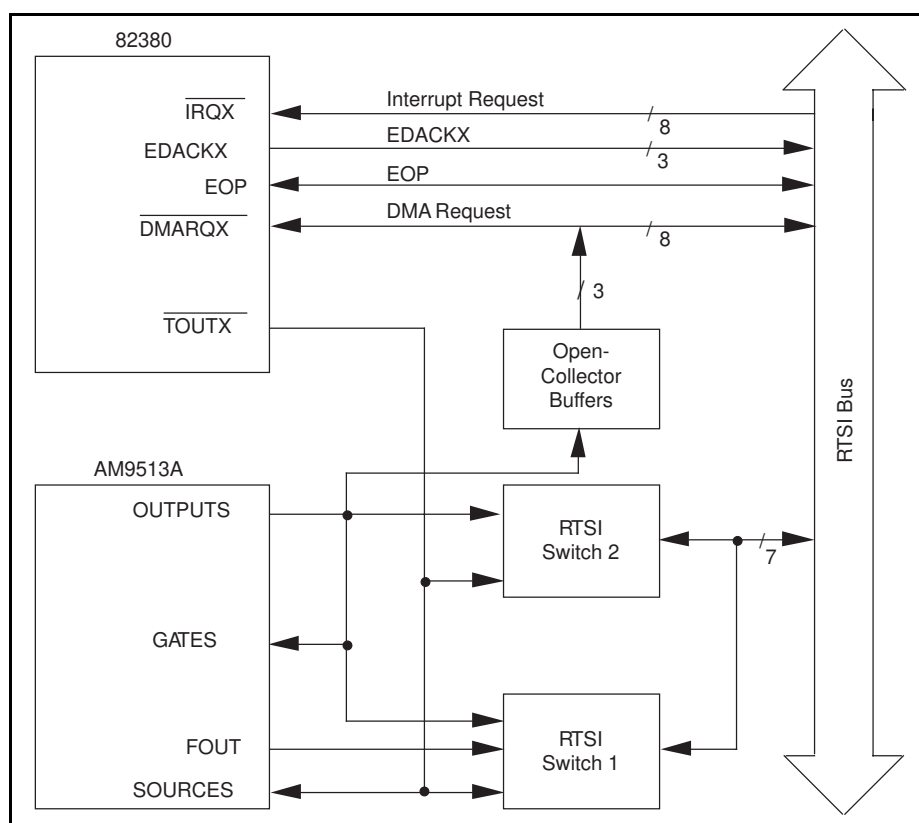

Figure 3-5. Am9513A Timer and RTSI Interface

# Chapter 4

## Programming

---

This chapter describes in detail the address and function of each of the NB-DMA2800 control and status registers. This chapter also includes important information about programming the NB-DMA2800.

### Register Access

The Macintosh uses memory mapping to access boards in the system. The following sections discuss how to access the various registers on the NB-DMA2800.

### Slot Address Space

Each slot in the Macintosh is allocated a block of Macintosh memory addresses known as the *slot address space*. All I/O boards plugged into Macintosh slots are therefore memory mapped. When an I/O board is plugged into a given slot, its registers can be accessed within that slot address space. The block of memory addresses allocated to each slot depends on the slot number and whether the Macintosh memory manager is in 24-bit or 32-bit addressing mode. The slots are labeled 9 through E next to the slot connectors inside the Macintosh II, IIx, and IIx; 9 through B inside the Macintosh IICx; C through E inside the Macintosh IICi; D through E inside the Quadra 700; and A through E inside the Quadra 900. The Macintosh IISI has a single slot labeled 9. Table 4-1 shows the slot address space for each slot, both for 24-bit compatibility mode and for 32-bit mode.

Table 4-1. Macintosh Slot Addresses

Slot Number	Base Address for 24-bit Compatibility Mode	Base Address for 32-bit mode
9	0090 0000	F900 0000
A	00A0 0000	FA00 0000
B	00B0 0000	FB00 0000
C	00C0 0000	FC00 0000
D	00D0 0000	FD00 0000
E	00E0 0000	FE00 0000

The register maps for the NB-DMA2800 are given in Table 4-2, Table 4-3, and Table 4-4. These tables list the register name, the register address offset from the slot base address, the type of the register (read only, write only, or read and write), and the size of the register in bits.

## Register Maps

Each register address in Table 4-2, Table 4-3, and Table 4-4 is the offset address from the slot starting address. To calculate the absolute address of a register, add the slot base address given in Table 4-1 to the register offset given in Table 4-2, Table 4-3, or Table 4-4. For example, if the NB-DMA2800 is plugged into slot B and the Macintosh is operating in 24-bit compatibility mode, the GPIB Monitor register is at location (B0 0000 + 2 0000); that is, address B2 0000 (hex).

Table 4-2. Register Map for the NB-DMA2800 Register Groups

Register Name	Offset Address (Hex)	Type	Size
Configuration Register Group			
Board Control Register	4 0000	Write-only	32-bit
Scan Circuitry Bypass Register	4 0007	Write-only	8-bit
EOP Interrupt Enable Register	4 000B	Write-only	8-bit
NuBus Block Mode Enable Register	4 000F	Write-only	8-bit
NuBus Flyby Enable Register	4 0013	Write-only	8-bit
NuBus MLock Enable Register	4 0017	Write-only	8-bit
RTSI Switch Register Group			
RTSI Switch 1 Shift Register	A 0000	Write-only	8-bit
RTSI Switch 2 Shift Register	C 0000	Write-only	8-bit
RTSI Switch 1 Strobe Register	A 0004	Write-only	8-bit
RTSI Switch 2 Strobe Register	C 0004	Write-only	8-bit
Am9513A System Timing Controller Register Group			
Data Port Register	6 0000	Read-and-write	16-bit
Command Port Register	6 0004	Write-only	16-bit
Status Register	6 0004	Read-only	16-bit

Refer to Appendix C, *AMD Data Sheet*, for information about the Am9513A Register Group.

Table 4-3. Register Map for the GPIB Interface Register Group

Register Name	Offset Address (Hex)	Type	Size
GPIB Interface Register Group			
μPD7210 Register Group			
Data In Register	0 0001	Read-only	8-bit
Command/Data Out Register	0 0001	Write-only	8-bit
Interrupt Status 1 Register	0 0005	Read-only	8-bit
Interrupt Mask 1 Register	0 0005	Write-only	8-bit
Interrupt Status 2 Register	0 0009	Read-only	8-bit
Interrupt Mask 2 Register	0 0009	Write-only	8-bit
Serial Poll Status Register	0 000D	Read-and-write	8-bit
Address Status Register	0 0011	Read-only	8-bit
Address Mode Register	0 0011	Write-only	8-bit
Command Pass-Through Register	0 0015	Read-only	8-bit
Auxiliary Mode Register	0 0015	Write-only	8-bit
Address Register 0	0 0019	Read-only	8-bit
Address Register 0/1	0 0019	Write-only	8-bit
Address Register 1	0 001D	Read-only	8-bit
End of String Register	0 001D	Write-only	8-bit
Turbo488 Register Group			
Status 1 Register	0 0021	Read-only	8-bit
Configuration Register	0 0021	Write-only	8-bit
Interrupt Mask 3 Register	0 0025	Read-and-write	8-bit
Count Low Register	0 0029	Read-and-write	8-bit
Count High Register	0 002D	Read-and-write	8-bit
FIFO Memory0 0030	Read-and-write	16-bit	
Interrupt Status 3 Register	0 0035	Read-only	8-bit
Carry Cycle Register	0 0035	Write-only	8-bit
Status Register 2	0 0039	Read-only	8-bit
Command Register	0 0039	Write-only	8-bit
Timer Register0 003D	Read-and-write	8-bit	
GPIB Monitor Register	2 0000	Read-and-write	16-bit



Table 4-4. Register Map for the 82380 Register Group

Register Name	Offset Address (Hex)	Type	Size
<b>82380 Register Group</b>			
<b>Channel 0 Registers</b>			
Target Address Register (Bytes <0..1>)	8 0000	Read-and-write	8-bit
Target Address Register (Byte 2)	9 0085	Read-and-write	8-bit
Target Address Register (Byte 3)	8 0010	Read-and-write	8-bit
Byte Count Register (Bytes <0..1>)	8 0001	Read-and-write	8-bit
Byte Count Register (Byte 2)	8 0011	Read-and-write	8-bit
Requester Address Register (Bytes <0..1>)	8 0090	Read-and-write	8-bit
Requester Address Register (Bytes <2..3>)	8 0091	Read-and-write	8-bit
<b>Channel 1 Registers</b>			
Target Address Register (Bytes <0..1>)	9 0000	Read-and-write	8-bit
Target Address Register (Byte 2)	9 0081	Read-and-write	8-bit
Target Address Register (Byte 3)	9 0010	Read-and-write	8-bit
Byte Count Register (Bytes <0..1>)	9 0001	Read-and-write	8-bit
Byte Count Register (Byte 2)	9 0011	Read-and-write	8-bit
Requester Address Register (Bytes <0..1>)	9 0090	Read-and-write	8-bit
Requester Address Register (Bytes <2..3>)	9 0091	Read-and-write	8-bit
<b>Channel 2 Registers</b>			
Target Address Register (Bytes <0..1>)	8 0004	Read-and-write	8-bit
Target Address Register (Byte 2)	8 0081	Read-and-write	8-bit
Target Address Register (Byte 3)	8 0014	Read-and-write	8-bit
Byte Count Register (Bytes <0..1>)	8 0005	Read-and-write	8-bit
Byte Count Register (Byte 2)	8 0015	Read-and-write	8-bit
Requester Address Register (Bytes <0..1>)	8 0094	Read-and-write	8-bit
Requester Address Register (Bytes <2..3>)	8 0095	Read-and-write	8-bit
<b>Channel 3 Registers</b>			
Target Address Register (Bytes <0..1>)	9 0004	Read-and-write	8-bit
Target Address Register (Byte 2)	9 0080	Read-and-write	8-bit
Target Address Register (Byte 3)	9 0014	Read-and-write	8-bit
Byte Count Register (Bytes <0..1>)	9 0005	Read-and-write	8-bit

(continues)

Table 4-4. Register Map for the 82380 Register Group (Continued)

Register Name	Offset Address (Hex)	Type	Size
Byte Count Register (Byte 2)	9 0015	Read-and-write	8-bit
Requester Address Register (Bytes <0..1>)	9 0094	Read-and-write	8-bit
Requester Address Register (Bytes <2..3>)	9 0095	Read-and-write	8-bit
Channel 4 Registers			
Target Address Register (Bytes <0..1>)	8 00C0	Read-and-write	8-bit
Target Address Register (Byte 2)	9 008D	Read-and-write	8-bit
Target Address Register (Byte 3)	8 00D0	Read-and-write	8-bit
Byte Count Register (Bytes <0..1>)	8 00C1	Read-and-write	8-bit
Byte Count Register (Byte 2)	8 00D1	Read-and-write	8-bit
Requester Address Register (Bytes <0..1>)	8 0098	Read-and-write	8-bit
Requester Address Register (Bytes <2..3>)	8 0099	Read-and-write	8-bit
Channel 5 Registers			
Target Address Register (Bytes <0..1>)	9 00C0	Read-and-write	8-bit
Target Address Register (Byte 2)	9 0089	Read-and-write	8-bit
Target Address Register (Byte 3)	9 00D0	Read-and-write	8-bit
Byte Count Register (Bytes <0..1>)	9 00C1	Read-and-write	8-bit
Byte Count Register (Byte 2)	9 00D1	Read-and-write	8-bit
Requester Address Register (Bytes <0..1>)	9 0098	Read-and-write	8-bit
Requester Address Register (Bytes <2..3>)	9 0099	Read-and-write	8-bit
Channel 6 Registers			
Target Address Register (Bytes <0..1>)	8 00C4	Read-and-write	8-bit
Target Address Register (Byte 2)	8 0089	Read-and-write	8-bit
Target Address Register (Byte 3)	8 00D4	Read-and-write	8-bit
Byte Count Register (Bytes <0..1>)	8 00C5	Read-and-write	8-bit
Byte Count Register (Byte 2)	8 00D5	Read-and-write	8-bit
Requester Address Register (Bytes <0..1>)	8 009C	Read-and-write	8-bit
Requester Address Register (Bytes <2..3>)	8 009D	Read-and-write	8-bit

(continues)

Table 4-4. Register Map for the 82380 Register Group (Continued)

Register Name	Offset Address (Hex)	Type	Size
<b>Channel 7 Registers</b>			
Target Address Register (Bytes <0..1>)	9 00C4	Read-and-write	8-bit
Target Address Register (Byte 2)	9 0088	Read-and-write	8-bit
Target Address Register (Byte 3)	9 00D4	Read-and-write	8-bit
Byte Count Register (Bytes <0..1>)	9 00C5	Read-and-write	8-bit
Byte Count Register (Byte 2)	9 00D5	Read-and-write	8-bit
Requester Address Register (Bytes <0..1>)	9 009C	Read-and-write	8-bit
Requester Address Register (Bytes <2..3>)	9 009D	Read-and-write	8-bit
<b>Group 1 Registers (Channels 0 through 3)</b>			
Command Register 1	8 0008	Write-only	8-bit
Command Register 2	9 0018	Write-only	8-bit
Mode Register 1	9 0009	Write-only	8-bit
Mode Register 2	9 0019	Write-only	8-bit
Software Request Register	8 0009	Read-and-write	8-bit
Mask Set/Reset Register	9 0008	Write-only	8-bit
Mask Read/Write Register	9 000D	Read-and-write	8-bit
Status Register8 0008	Read-only	8-bit	
Bus Word Size Register	8 0018	Write-only	8-bit
Chaining Register	8 0019	Read-and-write	8-bit
<b>Group 2 Registers (Channels 4 through 7)</b>			
Command Register 1	8 00C8	Read-and-write	8-bit
Command Register 2	9 00D8	Read-and-write	8-bit
Mode Register 1	9 00C9	Read-and-write	8-bit
Mode Register 2	9 00D9	Read-and-write	8-bit
Software Request Register	8 00C9	Read-and-write	8-bit
Mask Set/Reset Register	9 00C8	Write-only	8-bit
Mask Read/Write Register	9 00CD	Read-and-write	8-bit
Status Register8 00C8	Read-only	8-bit	
Bus Word Size Register	8 00D8	Write-only	8-bit
Chaining Register	8 00D9	Read-and-write	8-bit
<b>Software Command Register Group</b>			
Clear Byte Pointer Flip-Flop Register	8 000C	Write-only	8-bit
Master Clear Register	8 000D	Write-only	8-bit

(continues)

Table 4-4. Register Map for the 82380 Register Group (Continued)

Register Name	Offset Address (Hex)	Type	Size
Clear Mask Register (Channels 0 through 3)	9 000C	Write-only	8-bit
Clear Mask Register (Channels 4 through 7)	9 00CC	Write-only	8-bit
Clear TC Interrupt Request Register	9 001C	Write-only	8-bit
Programmable Interval Timer Register Group			
Counter 0 Register	8 0040	Read-and-write	8-bit
Counter 1 Register	8 0041	Read-and-write	8-bit
Counter 2 Register	9 0040	Read-and-write	8-bit
Control Word Register 1	9 0041	Write-only	8-bit
Counter 3 Register	8 0044	Read-and-write	8-bit
Control Word Register 2	9 0045	Write-only	8-bit
Internal Control Port	8 0061	Write-only	8-bit

Refer to Appendix D, *Intel Data Sheet*, for information about the 82380 Register Group.

**Note:** *Not all the Intel 82380 registers are listed in Table 4-4. To find the proper offset for an 82380 register, use the following procedure: if bit 1 (next to the least significant bit) of the register offset is 1, set bit 1 to 0 and set bit 16 to 1. Add the result to 8 0000 (hex), the offset of the 82380 group.*

Example: If the register offset given in Appendix D, *Intel Data Sheet*, is 0D, then the offset becomes 8 000D because bit 1 is 0 and the result is added to 8 0000. However, if the register offset of 0F, then the offset becomes 9 000D, because bit 1 is 1. Thus, bit 1 is changed to 0 and bit 16 is changed to 1.

## Register Word Sizes

The Macintosh accepts three different memory word sizes for memory read and write operations: byte (8-bit), half-word (16-bit), and word (32-bit). Table 4-2, Table 4-3, and Table 4-4 show the word sizes of the NB-DMA2800 registers. For example, a 16-bit read is required to access the first-in-first-out (FIFO) memory on the Turbo488, whereas an 8-bit write operation is required to program the RTSI Strobe 1 Register. All 82380 transactions are byte transactions.

**Note:** *Register sizes and access types given in this chapter take precedence over those specified in the appendixes.*

## Register Description

Table 4-2, Table 4-3, and Table 4-4 divide the NB-DMA2800 registers into different register groups. A bit description of each of the registers making up these groups is given later in this chapter or in the related appendix (Appendix C, *AMD Data Sheet*, or Appendix D, *Intel Data Sheet*).

The Configuration Register Group controls the overall operation of the NB-DMA2800 hardware. The RTSI Switch Register Group controls routing of the system timing and control signals over the RTSI bus trigger lines. The Am9513A System Timing Controller Register Group controls the programmable timers contained within the Am9513A IC. The GPIB Interface Register Group, including the Turbo488 and the  $\mu$ PD7210 Registers, controls the sophisticated GPIB interface used by the NB-DMA2800. The GPIB Monitor Register allows control and monitoring of the GPIB independent of the GPIB Interface Register Group and is used for hardware diagnostics. The 82380 Register Group controls the DMA controller (DMAC), interrupt controller, and programmable interval timer hardware contained within the 82380 integrated circuit (IC).

### Register Description Format

The remainder of this register description section discusses most of the NB-DMA2800 registers in the order shown in Table 4-2, Table 4-3, and Table 4-4. Each register group is introduced, followed by a detailed bit description of each register. Individual register descriptions give the address—*always* in hexadecimal, type, data size, and bit map of the register, followed by a description of each bit.

The register bit map shows a diagram of the register with the most significant bit (bit 31 for a 32-bit register, bit 15 for a 16-bit register, or bit 7 for an 8-bit register) shown on the left, and the least significant bit (bit 0) shown on the right. A square is used to represent each bit. Each bit is labeled with a name inside its square. An asterisk (\*) after the bit name indicates that the bit is inverted (negative logic).

In many of the registers, several bits are labeled with an *x*, indicating *don't care* bits. When a register is read, these bits may appear set or cleared but should be ignored because they have no significance. When a register is written to, setting or clearing these bit locations has no effect on the NB-DMA2800 hardware.

The bit map field for some write-only addresses state *not applicable, no bits used*. Writing to these addresses generates a strobe in the NB-DMA2800. These strobes are used to cause some onboard event to occur. For example, writing to the RTSI Switch Strobe Register loads the contents of the RTSI Switch Shift Register into the RTSI Switch Control Register. The data written to the Strobe Register is ignored.

## Configuration Register Group

The six registers making up the Configuration Register Group are used for general control of the NB-DMA2800 hardware. The Configuration Register Group contains bits that control operation of several different pieces of the NB-DMA2800 hardware.

Bit descriptions of the six registers making up the Configuration Register Group are given on the following pages.

## Board Control Register

The Board Control Register controls several NB-DMA2800 functions. Because it is accessed by 32-bit writes only, a software copy of its current state should be maintained. The Board Control Register is cleared at system startup.

Address: 4 0000

Type: Write-only

Word Size: 32-bit

Bit Map:

31	30	29	28	27	26	25	24
NMRIE	RTSIE	TDMA6	TDMA5	TDMA0	DRQ4	CMD1	CMD0
23	22	21	20	19	18	17	16
MODEB	LIMB2	LIMB1	LIMB0	MODEA	LIMA2	LIMA1	LIMA0
15	14	13	12	11	10	9	8
DMANMR*	X	X	X	X	X	X	X
7	6	5	4	3	2	1	0
X	X	X	X	X	X	X	X

Bit	Name	Description
31	NMRIE	Non-Master Request Interrupt Enable. Setting this bit allows the GPIB interface circuitry to interrupt the Macintosh II's 68020 microprocessor by asserting the NuBus NMR* signal.
30	RTSIE	RTSI Interrupt Enable. Setting this bit allows the GPIB interface circuitry to send an interrupt across one of the eight RTSI bus interrupts, INT*<7..0>. The interrupt line used is determined by the lower three bits of the NB-DMA2800 slot number. For example, if the NB-DMA2800 is in slot B, then the GPIB interrupt would use INT*3, because the lower three bits of hexadecimal slot number B equals 3.
29	TDMA6	Timer DMA request enable. Setting this bit connects the Am9513A Out4 signal to the DMARQ*6 line, allowing generation of periodic DMA requests.

<b>Bit</b>	<b>Name</b>	<b>Description (continued)</b>
28	TDMA5	Timer DMA request enable. Setting this bit connects the Am9513A Out2 signal to the DMARQ*5 line, allowing generation of periodic DMA requests.
27	TDMA0	Timer DMA request enable. Setting this bit connects the Am9513A Out3 signal to the DMARQ*0 line, allowing generation of periodic DMA requests.
26	DRQ4	Setting this bit connects DMARQ*0 to DMARQ*4, allowing 8-channel and 6-channel scanning modes. If this bit is clear, each scanning circuit operates independently and DMARQ*4 is driven by the GPIB interface DMA request line.
25	CMD1	Command high. This bit controls the scanning circuitry.
24	CMD0	Command low. This bit controls the scanning circuitry.
23	MODEB	This bit controls the mode of Scan Circuit B.
22-20	LIMB<2..0>	Limit parameters for Scan Circuit B.
19	MODEA	This bit controls the mode of Scan Circuit A.
18-16	LIMA<2..0>	Limit parameters for Scan Circuit A.
15	DMANMR*	Clearing this bit allows the 82380 INT pin to assert the NuBus NMR* signal.
14-0	X	Don't care bits.



### Scan Circuitry Bypass Register

Setting bit  $n$  in this register connects RTSI line  $\text{DMARQ}^*n$  directly to 82380 DMA Request Input  $\text{DREQ}n$ .

Address: 4 0007

Type: Write-only

Word Size: 8-bit

Bit Map:

7	6	5	4	3	2	1	0
SCB7	SCB6	SCB5	SCB4	SCB3	SCB2	SCB1	SCB0

Bit	Name	Description
7-0	SCB<7..0>	Scan Circuitry Bypass. Setting this bit will bypass the scan circuitry for DMA Channels 7 through 0, respectively, and connect the RTSI line $\text{DMARQ}^*7$ through $\text{DMARQ}^*0$ directly to the 82380 DMA request input $\text{DREQ}7$ through $\text{DREQ}0$ .

### EOP Interrupt Enable Register

Clearing bit  $n$  in this register enables an end of process (EOP) for DMA Channel  $n$  to trigger interrupt request 11 on the 82380.

Address: 4 000B

Type: Write-only

Word Size: 8-bit

Bit Map:

7	6	5	4	3	2	1	0
EIE*7	EIE*6	EIE*5	EIE*4	EIE*3	EIE*2	EIE*1	EIE*0

Bit	Name	Description
7-0	EIE*⟨7..0⟩	EOP Interrupt Enable. Clearing this bit enables an EOP for DMA Channels 7 through 0, respectively, to trigger interrupt request 11 on the 82380.

**Note:** After power on, all bits are clear; therefore, all EOP interrupts are enabled.

### NuBus Block Mode Enable Register

Setting bit  $n$  in this register enables NuBus block mode for DMA Channel  $n$ . 82380 DMA Channel  $n$  should be programmed for DMA flyby.

Address: 4 000F

Type: Write-only

Word Size: 8-bit

Bit Map:

7	6	5	4	3	2	1	0
NBE7	NBE6	NBE5	NBE4	NBE3	NBE2	NBE1	NBE0

Bit	Name	Description
7-0	NBE<7..0>	NuBus Block Mode Enable. Setting this bit enables NuBus block mode for DMA Channels 7 through 0, respectively. 82380 DMA Channels 7 through 0 should be programmed for DMA flyby.

### NuBus Flyby Enable Register

Setting bit  $n$  in this register enables NuBus flyby for DMA Channel  $n$ . 82380 DMA Channel  $n$  should be programmed for DMA flyby.

Address: 4 0013

Type: Write-only

Word Size: 8-bit

Bit Map:

7	6	5	4	3	2	1	0
NFE7	NFE6	NFE5	NFE4	NFE3	NFE2	NFE1	NFE0

Bit	Name	Description
7-0	NFE<7..0>	NuBus Flyby Enable. Setting this bit enables NuBus flyby for DMA Channels 7 through 0, respectively.

### NuBus MLock Enable Register

Setting bit  $n$  in this register enables NuBus master resource lock request for DMA Channel  $n$ . 82380 DMA Channel  $n$  should be programmed for DMA flyby.

Address: 4 0017

Type: Write-only

Word Size: 8-bit

Bit Map:

7	6	5	4	3	2	1	0
NMLE7	NMLE6	NMLE5	X	NMLE3	NMLE2	NMLE1	NMLE0

Bit	Name	Description
7-5, 3-0	NMLE<7..0>	NuBus MLock Enable. Setting this bit enables NuBus master resource lock request for DMA Channels 7 through 0, respectively. 82380 DMA Channels 7 through 0 should be programmed for DMA flyby.
4	X	Don't care bit.

## RTSI Switch Register Group

The four registers making up the RTSI Switch Register Group are used to program the NB-DMA2800 RTSI switch to route the signals on the RTSI bus trigger lines to and from several NB-DMA2800 signal lines. The RTSI switch is programmed by shifting a 56-bit routing pattern into the RTSI switch and then loading the internal RTSI Switch Control Register. The routing pattern is shifted into the RTSI switch by writing one bit at a time to the RTSI Switch Shift Register. The RTSI Switch Control Register is then loaded by writing to the RTSI Switch Strobe Register.

Bit descriptions for the registers making up the RTSI Switch Register Group are given on the following pages.

### RTSI Switch Shift Registers

The RTSI Switch Shift Registers are written to in order to load the RTSI switch internal 56-bit Control Register with routing information for switching signals to and from the RTSI bus trigger lines. The RTSI Switch Shift Registers are 1-bit registers and must be written to 56 times in order to shift the 56 bits into the internal registers.

Address:     A 0000     RTSI Switch 1  
               C 0000     RTSI Switch 2

Type:        Write-only

Word Size:   8-bit

Bit Map:

7	6	5	4	3	2	1	0
X	X	X	X	X	X	X	RSI

Bit	Name	Description
7-1	X	Don't care bits
0	RSI	RTSI Switch Serial Input. This bit is the serial input to the RTSI switch. Each time the RTSI Shift Register is written to, the value of this bit is shifted into the RTSI switch.

### RTSI Switch Strobe Registers

The RTSI Switch Strobe Registers are written to in order to load the contents of the RTSI Switch Shift Register into the RTSI Switch Control Register, thereby updating the RTSI switch routing pattern. The RTSI Switch Strobe Registers are written to after shifting the 56-bit routing pattern into the RTSI Switch Shift Registers. The data written to the Strobe Register is ignored.

Address:     A 0004         RTSI Switch 1  
              C 0004         RTSI Switch 2

Type:         Write-only

Word Size:    8-bit

Bit Map:       Not applicable, no bits are used



## **GPIB Register Group**

The GPIB Interface Register Group contains the sophisticated GPIB interface made up of the National Instruments Turbo488 and NEC  $\mu$ PD7210. National Instruments offers extensive software support for the GPIB functions of the NB-DMA2800, including the NI-488 handler that is included with the NB-DMA2800 and optional source code software support. The GPIB Interface Register Group also includes the GPIB Monitor Register that is connected directly to the GPIB, allowing control and monitoring of the GPIB independent of the Turbo488 and the  $\mu$ PD7210. This register is used for hardware diagnostics.

## GPIB Monitor Register

The bits of this register are connected directly to the GPIB lines.

Address: 2 0000

Type: Read-and-write

Word Size: 16-bit

Bit Map:

15	14	13	12	11	10	9	8
DIO*8	DIO*7	DIO*6	DIO*5	DIO*4	DIO*3	DIO*2	DIO*1
7	6	5	4	3	2	1	0
EOI*	ATN*	SRQ*	REN*	IFC*	NRFD*	NDAC*	DAV*

Bit	Name	Description
15-8	DIO*<8..1>	Data Input/Output. 8-bit bidirectional bus for the transfer of a message on the GPIB.
7	EOI*	End or Identify. Control line used to indicate the end of a multiple byte transfer sequence or to execute a parallel polling in conjunction with ATN.
6	ATN*	Attention. Control line which indicates whether the data on DIO lines is an interface message or a device-dependent message.
5	SRQ*	Service Request. Control line used to request the controller for service.
4	REN*	Remote Enable. Control line used to select remote or local control of the devices.
3	IFC*	Interface Clear. Control line used for clearing the interface functions.
2	NRFD*	Ready for Data. Handshake line indicating that the device is ready for data.
1	NDAC*	Data Accepted. Handshake line indicating the completion of message reception.
0	DAV*	Data Valid. Handshake line indicating that the data on DIO lines is valid.

## The Configuration EPROM

The Configuration EPROM is an onboard read-only memory that contains information required by the Macintosh operating system.

The Configuration EPROM on the NB-DMA2800 contains information about the NuBus interface and is required by the Macintosh. The Macintosh System Slot Manager reads the Configuration EPROM during system startup.

The Configuration EPROM is mapped to address offset E 0000 through F FFFC. The EPROM is 1 byte wide and 8 kbytes in length. Each byte of the EPROM is mapped to every fourth address location on the NB-DMA2800: the first byte is read from location (slot address + E 0000), the second byte is read from location (slot address + E 0004), and so on. With this mapping, there are four aliases of each EPROM location. Thus, E 0000 through E 7FFC equals E 8000 through E FFFC equals F 0000 through F 7FFC equals F 8000 through F FFFC.

## Programming Considerations

The remainder of this chapter contains programming instructions for operating the circuitry on the NB-DMA2800 board. Programming the NB-DMA2800 involves writing to and reading from the various registers on the board. The programming instructions list the sequence of steps to take. The instructions are language independent; that is, they instruct you to write a value to a given register, to set or clear a bit in a given register, or to detect whether a given bit is set or cleared without presenting the actual code.

### Register Programming Considerations

Registers in the Macintosh are memory mapped; that is, to write to a register, you must store a value in the appropriate memory location. To read a register, you must read the appropriate memory location. Only memory location reads and writes can be performed on the NB-DMA2800 registers. Mathematical or logical operations *cannot* be applied directly to the NB-DMA2800 registers. Attempting to do so results in unpredictable program behavior.

Several write-only registers on the NB-DMA2800 contain bits that control independent pieces of the onboard circuitry. In the instructions for setting or clearing bits, specific register bits must be set or cleared without changing the current state of the remaining bits in the register. However, writing to these registers affects all register bits simultaneously. You cannot read these registers to determine which bits have been set or cleared in the past; therefore, you need to maintain a software copy of the write-only registers. This software copy can then be read to determine the status of the write-only registers. To change the state of a single bit without disturbing the remaining bits, set or clear the bit in the software copy and write the software copy to the register.

## Initializing the NB-DMA2800 Board

Use the following steps to initialize the NB-DMA2800 DMA circuitry:

1. Write 0300 8000 to the Board Control Register (32-bit write) to reset the scanning circuitry. Follow with a write of 0000 8000 to the Board Control Register (32-bit write) to disable DMA requests from the Am9513A.
2. Write 00 to the 82380 Master Clear Register (offset = 8 000D) to reset the 82380 DMA controller (8-bit write).
3. Write 0F (hex) to the 82380 Mask Read/Write Registers to disable all DMA channels.

## Bus Error Handler Installation and Programming Considerations

Because the NB-DMA2800 occasionally issues a NuBus RETRY during slave operations (see Chapter 3, *Theory of Operation*), you must have a bus error handler installed. This bus error handler does several things. First, it checks that the bus error that occurred was indeed caused by a NuBus RETRY. Second, it checks that the bus error was a data cycle fault. Finally, the handler checks that the error was actually an access to an NB-DMA2800. If all of these tests succeed, the handler exits, and the access is tried again. Otherwise, the handler jumps to the previously installed bus error handler.

This bus error handler is automatically installed when National Instruments software is used. However, if you want to write your own software, you must install your own bus error handler. Save the original bus error handler address or vector that is found at address 00000008 of the system memory in a location where the original bus error vector can be obtained easily. Then, place the address of your new bus error handler at address 00000008 of the system memory.

**Note:** *You must take care to chain the bus error handler properly and to make sure that it is installed when needed. Occasionally, other software will unintentionally and temporarily remove your bus error handler.*

## NB-DMA2800 Programming Components

The five components making up the NB-DMA2800 that are used for programming are as follows:

- The DMA interface (Intel 82380 and scanning logic)
- The RTSI bus trigger interface—National Instruments RTSI switches
- The RTSI bus interrupt interface (Intel 82380)
- The GPIB interface—Turbo488 and the  $\mu$ PD7210 talker/listener/controller (TLC)
- The System Timing Controller interface (Am9513A and 82380 internal timers)

## DMA Interface Programming Considerations

The Intel 82380 DMA Controller (DMAC) on the NB-DMA2800 can be used for high-performance DMA service to the NB Series. This section describes the programming and operation of the DMA interface. For detailed DMA programming information refer to the Intel 82380 data sheet in Appendix D. Do *not* use the register offsets in the 82380 data sheet to access the 82380 registers. Instead, use the offsets given in Table 4-4 to access the 82380 registers, or use the address mapping procedure given earlier in this chapter.

### DMA Request Sources

The NB-DMA2800 receives DMA requests from a variety of sources.

The scanning circuitry connects the RTSI bus DMA request signals (DMARQ\* $\langle$ 7..5, 3..0 $\rangle$ ) to the appropriate DMA request inputs of the 82380 (DREQ $\langle$ 7..5, 3..0 $\rangle$ ). Any NB Series board that is connected to the NB-DMA2800 via the RTSI bus can then send a DMA request to the 82380. In response, the NB-DMA2800 can transfer data between Macintosh memory and the requesting board.

The DMA request of the GPIB interface circuitry or the RTSI DMARQ\*0 line drives the DMA request input DREQ4 of the 82380. The DRQ4 bit in the Board Control Register determines which line drives the DMA request input.

The Am9513A output signals Out2, Out3, and Out4 can drive the RTSI bus DMA request lines DMARQ\*5, DMARQ\*0, and DMARQ\*6, respectively, by programming the Board Control Register. This feature can be used to give a periodic DMA request signal to the 82380 for applications that require a constant supply of data, such as digital-to-analog (D/A) conversion.

In this case, when a counter is generating DMA request pulses, the DMA request scan circuitry should be used. This scan circuitry is discussed further in *Programming Multiple-Channel Operations* later in this chapter.

### DMA Transfer Modes

The DMA controller transfers data from the onboard GPIB or other NB Series board to the onboard GPIB, a third board, or to Macintosh memory. The board requesting DMA service is known as the requester. If the onboard GPIB is requesting service, then the NB-DMA2800 is the requester. The requester may request either a target read or a target write. The memory location from which data is read or to which data is written is the target.

Each of the eight DMA channels can operate in five different transfer modes. Each mode demands a specific requester handshaking protocol and transfers data at different speeds. Choose a mode that matches the capabilities and configurations of the NB Series boards that are requesting DMA service.

**Fetch-and-Deposit (Two-Cycle) Single-Transfer Mode.** The fetch-and-deposit (two-cycle) single-transfer mode is the slowest of the transfer modes. The requester must pulse high the DREQ line of the channel being used as each data becomes ready for transfer, or it can be held high for continuous transfer of data. Since this is a fetch-and-deposit (two-cycle) transfer, the NB-DMA2800 requires two cycles to complete each DMA transfer. The first cycle, called the fetch, is a read from either the target or the requester, depending on whether a target read or a target write is being performed. The second cycle, the deposit, is a write to either the requester or the target, again depending on whether a target read or a target write is being performed. Since this is a single-transfer operation, the DMA controller (DMAC) releases the local bus after each transfer (after the deposit). It must then request the local bus before the next transfer (before the fetch). The NB-DMA2800 transfers data as programmed until the byte count for the channel expires or until EOP\* is driven low by the requester.

Use the following steps to configure the NB-DMA2800 for fetch-and-deposit (two-cycle) single-transfer mode:

1. Program the desired DMA channel of the 82380 for fetch-and-deposit (two-cycle) single-transfer mode.
2. Program the Board Control Register and Scan Circuitry Bypass Register for the desired scan mode for flexibility in controlling DREQ for the appropriate channel.
3. Clear the bits for the channel being used in the NuBus Flyby Enable Register and in the NuBus Block Mode Enable Register.

**Fetch-and-Deposit (Two-Cycle) Demand Mode.** The fetch-and-deposit (two-cycle) demand mode provides the most control over the DMA transfer process. The requester drives the DREQ line of the desired channel high and holds it high to initiate the DMA transfer. Again, this is a fetch-and-deposit (two-cycle) transfer, so each DMA transfer requires two cycles—a fetch cycle and a deposit cycle. However, since this is a demand mode operation, the DMAC holds the local bus until it no longer has a DMA transfer to perform. This can be caused by termination of the DMA process by the byte count expiration for the channel being used or by the requester driving EOP\* low. The DMAC will also release the local bus if the requester interrupts the DMA process by driving the DREQ line low. The requester can restart the DMA transfer process where it left off by driving the DREQ line high again.

Use the following steps to configure the NB-DMA2800 for fetch-and-deposit (two-cycle) demand mode:

1. Program the desired DMA channel of the 82380 for fetch-and-deposit (two-cycle) demand mode.
2. Program the Board Control Register and Scan Circuitry Bypass Register for the desired scan mode for flexibility in controlling DREQ for the appropriate channel.
3. Clear the bits for the channel being used in the NuBus Flyby Enable Register and in the NuBus Block Mode Enable Register.

**NuBus Flyby (Single-Cycle) Single-Transfer Mode.** In NuBus flyby (single-cycle) single-transfer mode, each DMA transaction requires only one read or write cycle, depending on whether a target read or a target write is being performed. However, the NB-DMA2800 does not actually read or write the data. It merely initiates the read or write cycle. The requester must monitor the DMA acknowledge signals, EDACK<2..0>, on the RTSI bus to know when it is being serviced. If a target read is being performed, the NB-DMA2800 generates the target address and the NuBus control signals indicating a read transaction. The target then generates the data, and the requester must latch the data when it appears on the NuBus. If a target write is being performed, the NB-DMA2800 generates the target address and the NuBus control signals indicating a write transaction. The requester must then generate the data written to the target. DMA request handshaking is identical to that in fetch-and-deposit (two-cycle) single-transfer mode. The requester must pulse high the DREQ line of the channel being used as the data becomes ready for transfer, or it can be held high for continuous transfer of data. Again, since this is a single-transfer operation, the DMAC releases the local bus between each transfer as in fetch-and-deposit (two-cycle) single-transfer mode. The NB-DMA2800 transfers data as programmed until the byte count for the channel expires or until EOP\* is driven low by the requester.

Use the following steps to configure the NB-DMA2800 for NuBus flyby (single-cycle) single-transfer mode:

1. Program the desired DMA channel of the 82380 for flyby (single-cycle) single-transfer mode.
2. Program the Board Control Register and Scan Circuitry Bypass Register for the desired scan mode for flexibility in controlling DREQ for the appropriate channel.
3. Set the bit for the channel being used in the NuBus Flyby Enable Register.
4. Clear the bit for the channel being used in the NuBus Block Mode Enable Register.

**NuBus Flyby (Single-Cycle) Demand Mode.** In NuBus flyby (single-cycle) demand mode, as in NuBus flyby (single-cycle) single-transfer mode, each DMA transaction requires only one read or write cycle. The NB-DMA2800 generates the target address and the control signals necessary to initiate a read or a write cycle. The requester must then latch the data from a target read or generate the data for a target write. DMA request handshaking is identical to that in fetch-and-deposit (two-cycle) demand mode. The requester drives the DREQ line of the desired channel high and holds it high to initiate the DMA transfer. The NB-DMA2800 transfers data continuously from the requester to the target until the byte count for the channel being used expires or until the requester drives EOP\* low. The requester can interrupt the DMA transfer process by driving the DREQ line low. The requester can restart the DMA transfer process where it left off by driving the DREQ line high again. Since this is demand mode, the DMAC holds the local bus until it no longer has a DMA transfer to perform

Use the following steps to configure the NB-DMA2800 for NuBus flyby (single-cycle) demand mode:

1. Program the desired DMA channel of the 82380 for flyby (single-cycle) demand mode.

2. Program the Board Control Register and Scan Circuitry Bypass Register for the desired scan Mode for flexibility in controlling DREQ for the appropriate channel.
3. Set the bit for the channel being used in the NuBus Flyby Enable Register.
4. Clear the bit for the channel being used in the NuBus Block Mode Enable Register.

NuBus Block Mode. NuBus block mode operates in a manner very similar to NuBus flyby (single-cycle) demand mode except that instead of one 32-bit (or 16-bit or 8-bit) word being transferred with each NuBus cycle, sixteen 32-bit words are transferred for each NuBus cycle. This allows a more efficient use of NuBus bandwidth when both the requester and the target can handle block mode. Again, this is a flyby (single-cycle) transaction, so the NB-DMA2800 generates the starting target address for the block and the control signals that initiate the NuBus block-mode read or write. The requester must latch the 16-word data block generated by the target from a target read or generate the 16-word data block written to the target for a target write. DMA handshaking is similar to that in fetch-and-deposit (two-cycle) or flyby (single-cycle) demand mode. The requester drives the DREQ line of the desired channel high and holds it high to initiate the DMA transfer. The NB-DMA2800 transfers blocks of data continuously until the byte count for the channel being used expires or until the requester drives EOP\* low. The requester can interrupt the DMA transfer process between block transfers by driving the DREQ line low. The requester can restart the DMA transfer process where it left off by driving the DREQ line high again

Use the following steps to configure the NB-DMA2800 for NuBus block mode:

1. Program the desired DMA channel of the 82380 for flyby (single-cycle) demand mode. *Do not* program it for block mode. NuBus block mode is different from 82380 block mode.
2. Program the Board Control Register and Scan Circuitry Bypass Register for the desired scan mode for flexibility in controlling DREQ for the appropriate channel.
3. Set the bits for the channel being used in the NuBus Block Mode Enable Register and in the NuBus Flyby Enable Register.

### Programming Single-Channel DMA Operations

The NB-DMA2800 can be used for both single-channel and multiple-channel DMA operations. This section describes the sequence of events to conduct a single-channel DMA operation.

DMA Controller Setup. After initialization, use the following steps to prepare the 82380 DMA controller

1. Program the Command Register 1 and Command Register 2 in the 82380 to set the global operating characteristics of the DMA controller.



2. Program the Mode Register 1, Mode Register 2, and Bus Size Register in the 82380 to set the operating characteristics of the particular channel involved. Select the transfer type, data size, and operating modes.
3. Program the channel address and transfer count registers for the current operation.
4. Enable the programmed channel via the Mask Set/Reset Register or the Mask Read/Write Register.

The 82380 was designed for upward compatibility with the Intel 8237 DMA controller. For all programming of the 82380, 8-bit accesses *must* be used. The two low-order bytes of the target address, requester address, and byte count appear at one address offset. An internal flip-flop selects one of the registers for the current access; the flip flop toggles after each access. Writing to the Clear Byte Pointer Flip-Flop Register clears the flip-flop (see Appendix D, *Intel Data Sheet*). For example, use the following steps to program the low-order 16 bits of the target address for Channel 0:

1. Write to the Clear Byte Pointer Flip-Flop Register (8-bit write) to reset the byte pointer flip-flop.
2. Write the low-order byte of the address to the Target Address Register (offset 8 0000) to write bits 7 through 0 and to toggle (set) the byte pointer flip-flop.
3. Write the second byte of the address to the Target Address Register (offset 8 0000) to write bits 15 through 8 and to toggle the flip-flop back to the reset state.

Only those accesses which address multiple registers toggle the flip-flop. The 82380 data sheet in Appendix D lists which register accesses toggle the flip-flop.

**DMA Transfer Operation.** Once the channel is programmed, two events can initiate DMA transfers. External hardware can request DMA service by asserting the appropriate DMA request signal or software can initiate the transfer by setting the proper bit in the Software Request Register. When the 82380 receives a DMA Request on an enabled DMA channel, it requests the local bus of the NB-DMA2800. The interface circuitry grants the DMAC the local bus and determines whether an onboard GPIB transfer or an off-board NuBus transfer is required. If a NuBus transfer is required, the NB-DMA2800 arbitrates to become a NuBus master. When the NB-DMA2800 finally wins arbitration, it performs the necessary transfer. If a GPIB transfer is required, the 82380 transfers data directly to or from the Turbo488 without going out over the NuBus. This is repeated until the 82380 has no more transfers to perform. Then the 82380 finally releases the local bus to any other NuBus master that may want to access it.

**DMA Termination.** Once a DMA transfer is in progress, it can be terminated in the following three ways.

- The 82380 Current Byte Count Register decrements to zero. When this occurs, the 82380 asserts the EOP\* signal during the last requester bus cycle and the DMA channel becomes idle. The channel cannot be used again until it is reprogrammed.

- The DMA requester device asserts the EOP\* signal. This signal can be driven by other NB Series boards via the RTSI bus (see Appendix B for the RTSI bus pinout). For more information on programming the 82380 DMA controller to respond to the EOP\* signal, see the 82380 data sheet in Appendix D.
- Software sets the DMA Channel mask in the Mask Set/Reset Register or the Mask Read/Write Register. The DMA transfer starts back up from where it left off when the DMA mask is cleared.

### Programming Multiple-Channel DMA Operations

The NB-DMA2800 has the ability to coordinate activity on eight, independent DMA channels. DMA requests generated by various devices (that is, devices on the RTSI bus, the GPIB interface, or a timer output) do not connect directly to the 82380 DMA controller. Rather, special scan circuitry monitors these DMA requests and routes them to the 82380.

This manual refers to a Channel  $n$  DMA request on the device RTSI Bus side of the scan circuitry as  $DMARQ^*n$  and to a Channel  $n$  DMA request on the 82380 side of the scan circuitry as  $DREQn$ .  $DMARQ^*<7..0>$  are scan circuitry inputs and  $DREQ<7..0>$  are scan circuitry outputs that feed directly into the 82380  $DREQ<7..0>$  inputs. The scan circuitry is divided into two parts: scan circuit A monitors  $DMARQ^*<3..0>$  and drives  $DREQ<3..0>$  and scan circuit B monitors  $DMARQ^*<7..4>$  and drives  $DREQ<7..4>$ .

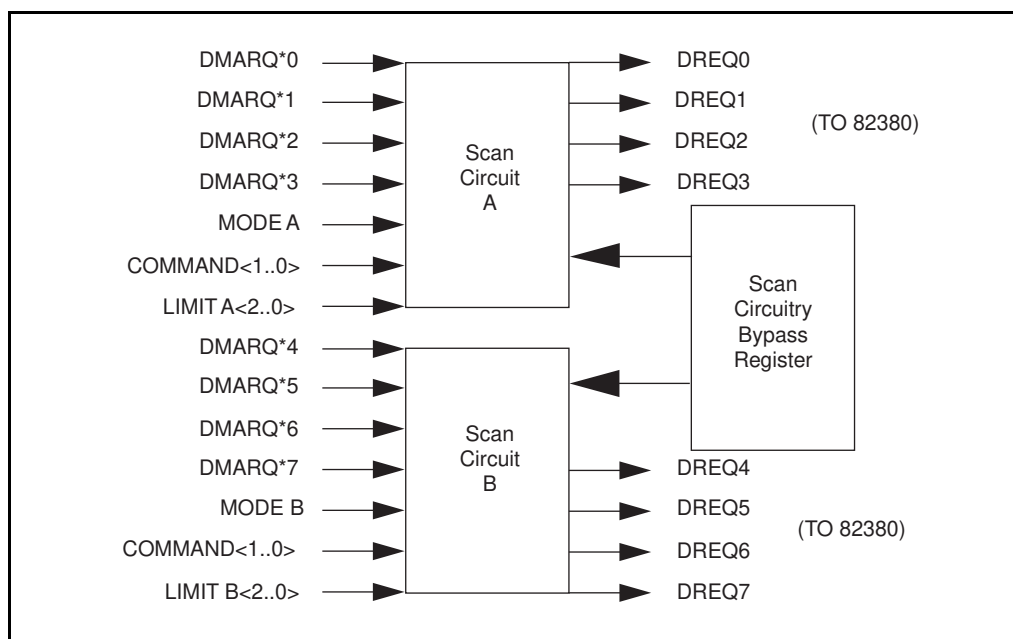

Figure 4-1. Scan Circuitry

Each scan circuit has a 3-bit LIMIT input, and a 1-bit MODE input, both of which are controlled by the Board Control Register. The Board Control Register contains separate LIMIT and MODE fields for each of the two scan circuits, but a single COMMAND field controls both.

Setting bit  $n$  in the Scan Circuitry Bypass Register drives DREQ $n$  directly from inverted DMARQ $n$ , thus bypassing the scan circuitry. Clearing bit  $n$ , however, puts the scan circuitry in the path of the DMARQ $n$  signal, and hence, the DREQ $n$  line is driven in accordance with MODE, COMMAND, and LIMIT inputs to the scan circuitry and the state of the DMARQ $n$  signal.

When using the scan circuitries, the assertion of DMARQ $n$  always asserts DREQ $n$  except when DMARQ $0$  is used; in this case, the response of DREQ $\langle 7..0 \rangle$  depends on the scanning mode of operation, as shown in Table 4-6.

The scan circuits also offers control when the DREQ signals are turned off. While programming the 82380 DMAC, your program may indicate the requester address as memory mapped or I/O mapped. If a device asserts DMARQ $n$ , the scan circuitry responds by asserting DREQ $n$ . If the requesting device is I/O mapped, the scan circuitry negates DREQ $n$  as soon as the 82380 begins to service the request. If, on the other hand, the requesting device is memory mapped, the scan circuitry negates DREQ $n$  when the device negates DMARQ $n$  only on the condition that the MODE bit for that particular scan circuit is cleared (see Table 4-5).

Table 4-5. Scan Circuitry for 82380 DMAC

MODE bit	Requester Mapping	DREQ $n$ Unassertion
0	memory	DREQ $n$ unasserts when DMARQ $n$ unasserts.
0	I/O	DREQ $n$ unasserts either when DMARQ $n$ unasserts or when the requested DMA transfer takes place, whichever occurs first.
1	memory	ILLEGAL
1	I/O	DREQ $n$ unasserts when the requested DMA transfer takes place.

Software means of asserting and deasserting a particular DREQ signal via the scan circuitry is presented later with COMMAND field descriptions.

The following channel scanning modes are determined by the MODE input to each scan circuitry:

- Cyclic scanning - If the MODE bit is clear, the scan circuit routes each assertion of DMARQ $0$  to DREQ $\langle n..0 \rangle$  on a cyclic basis, changing to the next DREQ whenever DMARQ $0$  is reasserted. An internal 3-bit counter selects which DREQ line the assertion of DMARQ $0$  activates. The LIMIT field selects the counter wrap-around value.
- Parallel scanning - If the MODE bit is set, the scan circuit routes each DMARQ $0$  to all DREQ $\langle n..0 \rangle$  lines simultaneously. The internal counter is not used. The LIMIT field specifies which of DREQ $\langle n..0 \rangle$  to assert (see Table 4-6).

Table 4-6. Legal Scan Modes—COMMAND&lt;1..0&gt; = 00

ModeA	ModeB	DRQ4	LIMITA <2..0>	LIMITB <2..0>	Description
0	0	0	000	000	Normal mode - each DMARQ*n causes the assertion of DREQn only
0	0	0	001	000	Cyclic scan - each DMARQ*0 causes the assertion of DREQ<1..0> in cycle
0	0	0	011	000	Cyclic scan - each DMARQ*0 causes the assertion of DREQ<3..0> in cycle
0	0	1	111	111	Cyclic scan - each DMARQ*0 causes the assertion of DREQ<7..0> in cycle
1	1	0	000	000	Normal mode - each DMARQ*n causes the assertion of DREQn only
1	1	0	001	000	Parallel scan - each DMARQ*0 causes the simultaneous assertion of DREQ<1..0>
1	1	0	011	000	Parallel scan - each DMARQ*0 causes the simultaneous assertion of DREQ<3..0>
1	1	1	111	000	Parallel scan - each DMARQ*0 causes the simultaneous assertion of DREQ<4..0>
1	1	1	111	001	Parallel scan - each DMARQ*0 causes the simultaneous assertion of DREQ<5..0>
1	1	1	111	111	Parallel scan - each DMARQ*0 causes the simultaneous assertion of DREQ<7..0>

When the COMMAND field is used for software control of the scan circuits, the following operations are possible:

1. If COMMAND<1..0> = 00 the scan circuits operate normally. In particular, the LIMIT field has the meaning described above.
2. If COMMAND<1..0> = 01 the scan circuit asserts DREQ $n$  where  $n$  is given by LIMITA<2..0> for  $0 \leq n \leq 3$  or by LIMITB<2..0> for  $4 \leq n \leq 7$ .
3. If COMMAND<1..0> = 10 the scan circuit deasserts DREQ $n$  where  $n$  is given by LIMITA<2..0> for  $0 \leq n \leq 3$  or by LIMITB<2..0> for  $4 \leq n \leq 7$ .
4. If COMMAND<1..0> = 11 and LIMIT=000, a scan circuit clears its internal counter. Since each circuit has a dedicated LIMIT field, counters can be cleared individually.

For cases 2, 3, and 4, the LIMIT field contains a command parameter rather than the counter wrap-around value. If DMARQ\*0 negates while the wrap-around value is absent, the scan circuitry might not operate properly. For this reason, the scan circuitry locks the DMA controller off the bus unless COMMAND<1..0> = 00.

Scan circuit B operates in the same manner as scan circuit A, except that DMARQ\*4 operates the scan circuitry. Setting the DRQ4 bit in the Board Control Register enables DMARQ\*0 to drive DMARQ\*4, allowing the two circuits to operate as a single unit. Notice that when in cyclic mode of operation and using DREQ<7..0> or in parallel scan mode and using DREQ<4..0>, DREQ<5..0>, or DREQ<7..0>, the DRQ4 bit for scan circuit B should be set in the Board Control Register.

Refer to *Board Control Register* for the bit patterns used to select the various scan circuitry commands and modes. The following guidelines should be referred to whenever deciding whether to use the scan circuitry or to bypass it and connect the inverted DMARQ\* signals directly to the DREQ inputs of the 82380.

You should use the scan circuitry in the following situations:

- If a pulsed DMARQ\* signal is used that cannot be guaranteed to have the correct duration (that is, the signal is either too long or too short), the scan circuitry should be used in order to meet the 82380's input timing requirements.
- If the onboard NB-DMA2800 counters are used to drive the DMARQ\* inputs (a special instance of the case above).
- If cyclic scanning is used on the NB-DMA2800 to service an A/D board with multiple analog channels that interleaves its acquired data into a single FIFO memory and place the results in multiple buffers. An example of this is when the NB-DMA2800 is used with the National Instruments NB-MIO-16, a 16-channel A/D conversion board, that can sample 16 analog signals, but interleaves its results into a single FIFO memory. If the NB-MIO-16 is sampling four analog signals and uses DMARQ\*0 for its DMA request, the scan circuitry can be configured to generate DREQ<3..0> on a cyclic basis. Thus, the NB-DMA2800 removes values from the NB-MIO-16 FIFO memory and places them in four separate buffers in Macintosh memory.
- If parallel scanning is used on the NB-DMA2800 to service a D/A board with multiple channels that share a common update clock. Thus, if this update clock generates DMARQ\*0, the scan circuitry will generate multiple DMA requests to reload the buffers for the multiple D/A channels. When the next update pulse comes, these multiple values are output to the multiple DACs on the D/A board. An example of this is the National Instruments NB-AO-6, a 6-channel D/A conversion board that uses a common update pulse to clock digital values from its onboard buffers into its six DACs.

You should bypass the scan circuitry in the following situations:

- If the scan circuitry automatically deasserts a DREQ signal upon the first access to the requester. Therefore, in situations where the unbroken assertion of the DREQ signal is required, such as in demand mode, NuBus Block mode (which utilizes the 82380 demand mode), or in single transfer modes in which the DMA request signal is kept asserted until there is no data to be transferred, the scan circuitry should be bypassed.
- If, for the fastest response, any requesting device that can meet DREQ input timing requirements and does not require either parallel or cyclic scan modes of service should bypass the scan circuitry. Proper timing refers to the removal of the DMARQ\* signal at the end of the start cycle for normal NuBus cycles and the beginning of the acknowledge cycle for block mode cycles that are servicing the device, if the device is serviced and requires no more transfer cycles.
- If the requesting device continually, that is, cyclically, asserts DMARQ\* but cannot be guaranteed to remove it quickly enough, then the scan circuitry may be bypassed if the requesting device is involved in a two-cycle (fetch-and-deposit) transaction, is being read from, and is capable of removing the DMARQ\* signal by the start of the write cycle, which follows the read cycle, after the requesting device no longer needs service.
- During fetch-and-deposit transfers in which the requesting device is being written to or data is being packed, the scan circuitry may be bypassed as long as proper input timing for the 82380 is met.

### **RTSI Bus Trigger Interface Programming Considerations**

The NB-DMA2800 is equipped with a National Instruments RTSI bus interface. The RTSI bus connector is located on the top edge of the NB-DMA2800 board. A 50-pin ribbon cable connects two or more NB Series boards to the RTSI bus. The RTSI bus allows DMA, interrupt, and additional control signals to be sent from one board to another. There are seven RTSI bus trigger lines (TRIG<6..0>) that, under program control, can be connected in any combination with the RTSI bus trigger lines from another NB Series board. A pinout of the RTSI bus connector is given in Appendix B.

Each NB Series board assigns different control lines to the RTSI bus according to the applications of the board. The NB-DMA2800 has two RTSI switches tied to the RTSI bus (notice that only one should be driving a specific RTSI bus line at any time). Table 4-7 lists the signals tied to the two RTSI switches.

Table 4-7. RTSI Switch Signals

RTSI Switch Pin	Switch 1 Signal	Switch 2 Signal
A6	Am9513A Gate1	Am9513A Output 1
A5	Am9513A Gate3	Am9513A Output 2
A4	Am9513A Gate5	Am9513A Output 3
A3	Am9513A Source 3	Am9513A Output 4
A2	Am9513A Source 4	Am9513A Output 5
A1	Am9513A Source 5	82380 Tout2*
A0	Am9513A Fout	82380 Tout3*
B0	Trig0	Trig0
B1	Trig1	Trig1
B2	Trig2	Trig2
B3	Trig3	Trig3
B4	Trig4	Trig4
B5	Trig5	Trig5
B6	Trig6	Trig6
* indicates an active low signal		

Figure 4-2 shows a simplified diagram of the RTSI switch internal circuitry. Each terminal can act as an input or an output. After reset, all A and B terminals assume a high impedance state. When a B terminal is configured as an output, it can be programmed to track any one of the A terminals. Similarly, when an A terminal is configured as an output, it can be programmed to track any one of the B terminals.

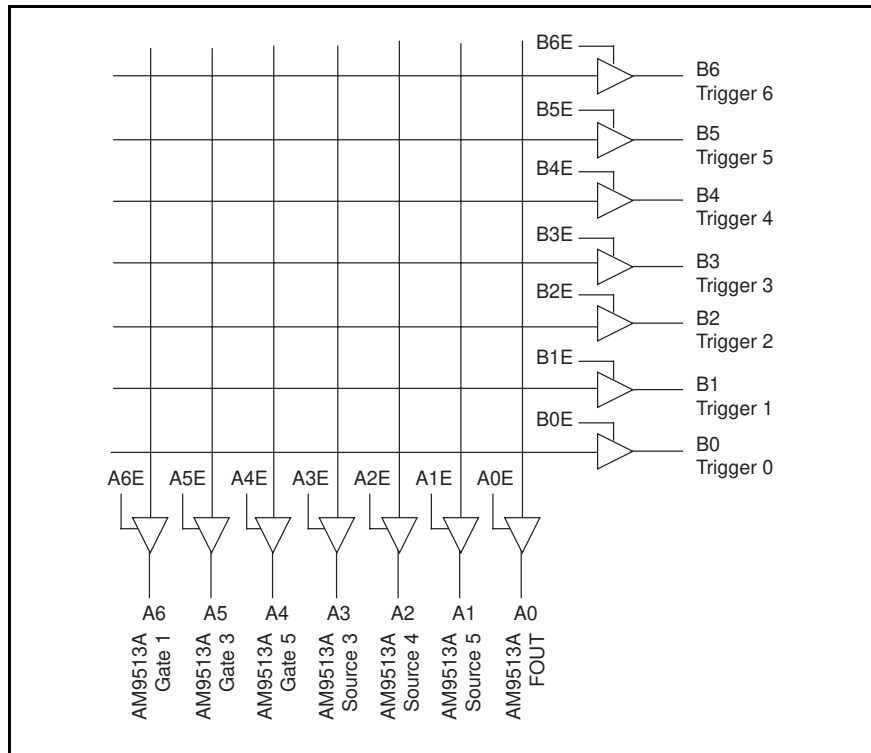

Figure 4-2. The RTSI Switch 1 Trigger Lines

The RTSI bus trigger lines are configured by performing 56 one-bit writes to the RTSI Switch Shift Register followed by one write to the RTSI Switch Strobe Register. Each terminal requires four bits of control information. Three bits specify which opposing terminal to track (A<n..0> terminals always track one of B<n..0> and vice versa); the final bit controls the output enable—a set bit enables the output (see Figure 4-3).

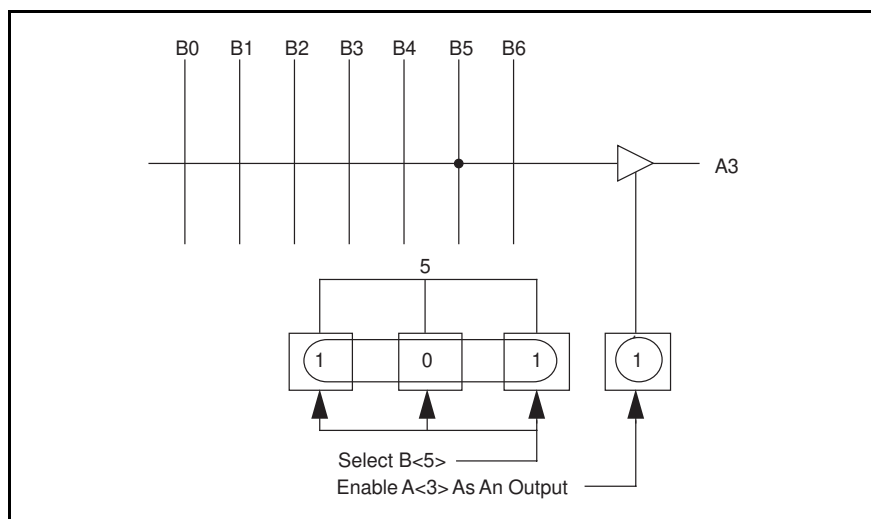

Figure 4-3. Gating B<5> onto A<3>



To configure a terminal as an input, select the bit pattern XXX0 where the last bit disables the output driver (thus configuring the terminal as an input) and the first three bits are *don't care bits* since the terminal will not be tracking any other terminal. Any or all B terminals can be programmed to track an A terminal configured as an input and likewise, any or all A terminals can be programmed to track a B terminal configured as an input.

The first four bits of a 56-bit group control the B0 terminal; the next four control the B1 terminal, and so on. The first bit written within a group of four controls the output enable. The next three indicate the opposing terminal number—least significant bit written first.

This bit ordering allows a clear memory representation of programming information. A complete 56-bit control pattern resides in two 68020 long words. Figure 4-4 shows the terminal mapping of the long words.

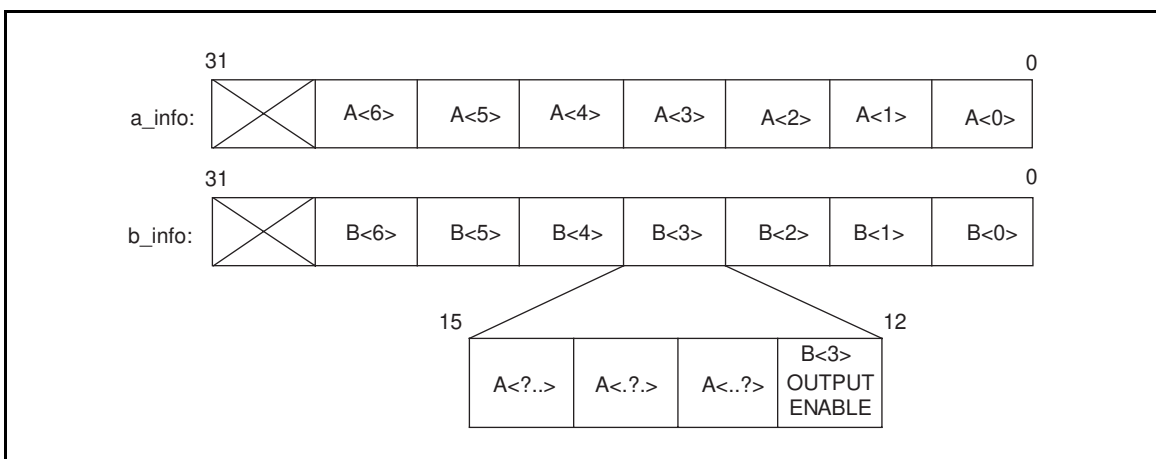

Figure 4-4. Data Used to Configure the RTSI Trigger Lines

The following C code illustrates the RTSI switch programming process:

```

d0 = b_info; /* program B<6:0> first */
for (i=0; i<28; i++) { /* 28 bits for B terminals */
    *RSHIFT1= d0; /* write a bit to RTSI shift 1 register */
    d0 >>= 1; /* shift over to next bit */
}
d0 = a_info; /* repeat above for A<6:0> */
for (i=0; i<28; i++) {
    *RSHIFT1 = d0;
    d0 >>= 1;
}
*RSTROBE1 = 0; /* write the RTSI 1 strobe register */

```

The four registers making up the RTSI Switch Register Group allow the NB-DMA2800 RTSI switches to be programmed to route RTSI bus trigger lines to and from the Am9513A System Timing Controller units.

## RTSI Bus Interrupt Interface Programming Considerations

The NB-DMA2800 is able to service interrupts via the RTSI bus lines (INT\* <7..0>). The RTSI bus interface can be used to receive interrupts from other NB Series boards and the interrupts are then handled by the Intel 82380 on the NB-DMA2800. The Intel 82380 contains an interrupt controller that handles 15 external interrupt sources. These interrupt sources are given in Table 4-8.

Table 4-8. 82380 External Interrupt Sources

Interrupt Request	Source
11	Masked EOP output from 82380
12	Not Used†
13	Not Used†
14	Not Used†
15	Not Used†
16	RTSI INT*0
17	RTSI INT*1
18	RTSI INT*2
19	RTSI INT*3
20	RTSI INT*4
21	RTSI INT*5
22	RTSI INT*6
23	RTSI INT*7

† The Not Used interrupt inputs are pulled up to 5 V.  
\* Indicates an active low signal

Refer to Appendix D, *Intel Data Sheet*, for more information on interrupt programming.

## GPIB Interface Programming Considerations

The NI-488 handler included with your NB-DMA2800 board includes all software necessary to use the GPIB interface. However, National Instruments offers optional, extensive source code software support for the GPIB functions of the NB-DMA2800. Consult your National Instruments catalog or call National Instruments for a complete, up-to-date list of the NB-DMA2800 software.

## System Timing Controller Interface Programming Considerations

The registers making up the System Timing Controller Register Group are divided between two integrated circuits. The Am9513A timer contains five 16-bit counter units that can be used to drive or sample any RTSI trigger line or to supply a constant DMA request source to the Intel 82380 DMA Controller. The Intel 82380 contains four 16-bit timer units. Timer 0 is dedicated as an event counter and does not have an external output. Timer 2 and 3 outputs are general purpose and can be used with the RTSI bus. Timer 1 output is dedicated to supplying a master clock for the Am9513A. To use the Am9513A, the 82380 Timer 1 must be configured to supply a master clock to the Am9513A. To do this, use the following procedure:

1. Write the 8-bit value 76 (hex) to the 82380 Control Word 1 Register (offset 90041) to select counter 1 for Mode 3 (binary counting operation).
2. Write the frequency divider to the counter 1 register (offset 80041) low-order byte first followed by the high-order byte. For example, for 1-MHz operation of the Am9513A, write 000A (hex); this will divide the 82380 internal clock which is running at 10 MHz by 10 to produce a 1 MHz clock.
3. The counter begins operation and the Am9513A clock is now valid, thus programming of the Am9513A can begin.

The configuration of the System Timing Controller unit gates, sources, and outputs is illustrated in Figure 4-5. For detailed register descriptions and programming information, refer to Appendix C and Appendix D. For more information on configuring the RTSI switches, see *RTSI Bus Trigger Interface Programming* in this chapter.

The Am9513A output signals Out2, Out3, and Out4 can be used to generate constant DMA request sources across the RTSI DMA Request Bus, which feed back to the 82380 DMA request inputs. The output signals Out2, Out3, and Out4 can be programmed to drive DMA request lines DMARQ\*5, DMARQ\*0, and DMARQ\*6 respectively by setting bits in the Board Control Register. For information on programming the Board Control Register see *DMA Interface Programming Considerations* in this chapter.

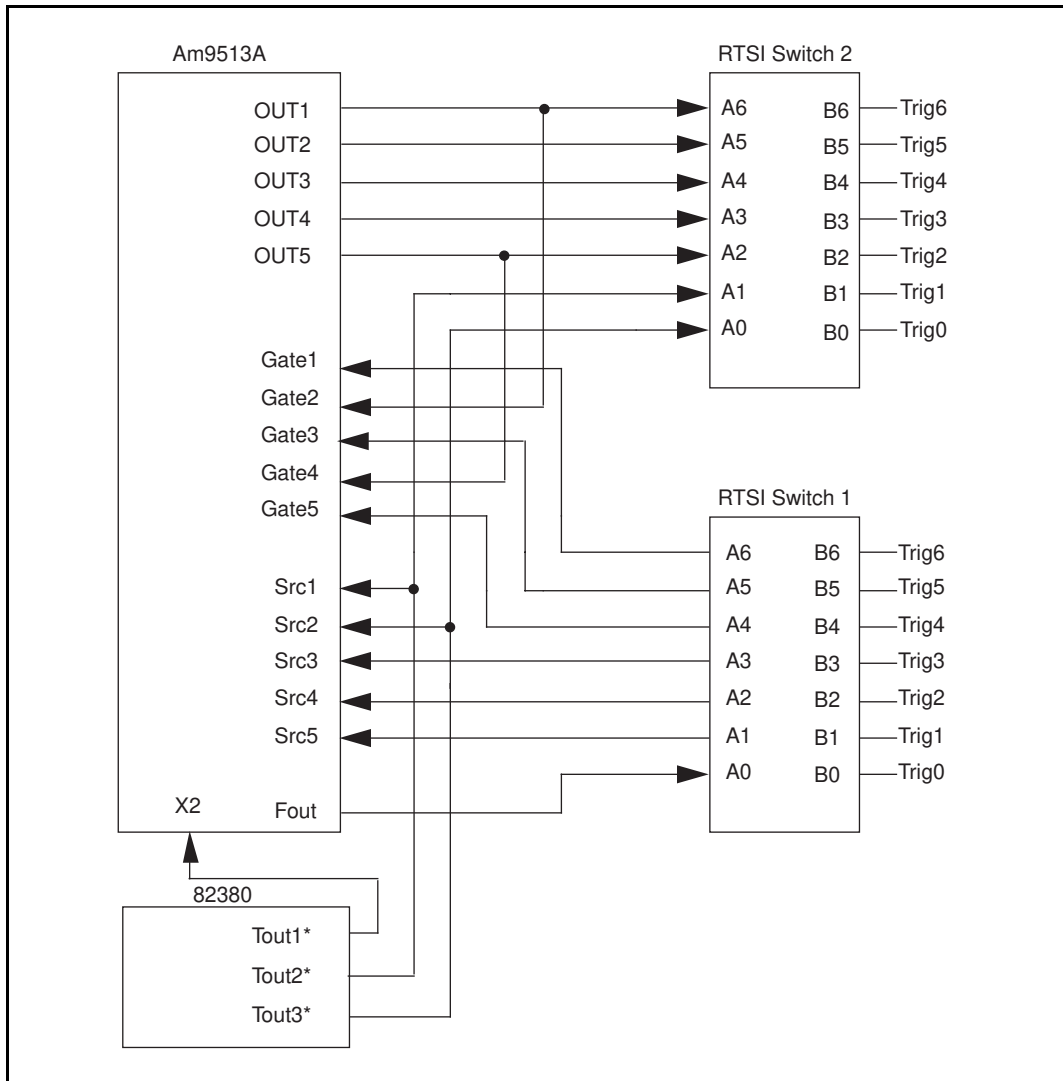

Figure 4-5. System Timing Controller Configuration

# Appendix A

## Specifications

---

This appendix lists the specifications for the NB-DMA2800. These specifications are typical at 25° C unless otherwise noted.

### Maximum DMA Transfer Rates

To Macintosh NuBus memory Fetch-and-deposit (from NB-MIO-16) .....	1.0 Mbytes/s
Flyby (from NB-A2200) .....	3.1 Mbytes/s
To block-mode memory (from NB-A2200)	
Macintosh Quadra memory .....	7.0 Mbytes/s
Two-wait-state memory .....	29 Mbytes/s
Zero-wait-state memory .....	32 Mbytes/s

### Maximum IEEE 488 Transfer Rates

Reads .....	850 kbytes/s
Writes .....	700 kbytes/s

### Power Requirement

+5 (±5%) VDC .....	1.7 mA
+12 (±5%) VDC .....	.60 mA typ

### Physical

Dimensions .....	32.6 by 10.2 cm (12.9 by 4.0)
I/O connector .....	IEEE 488 standard, 24-pin connector

### Environment

Operating temperature .....	0° to 70° C
Storage temperature .....	-55° to 150° C
Relative humidity .....	5% to 90%

# Appendix B

## I/O Connector Pinouts

This appendix shows the pinouts and signal names of the GPIB input/output (I/O) connector, the NuBus pin assignments, and the Real-Time System Integration (RTSI) bus connector pinout.

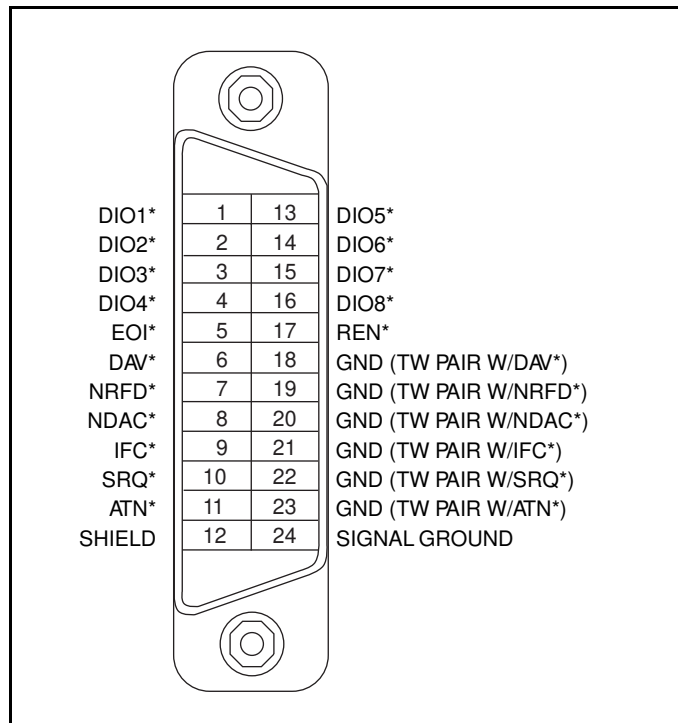

Figure B-1. GPIB Connector

Pin	Row		
	A	B	C
1	-12	-12	RESET*
2	Reserve	GND	Reserve
3	d	GND	d
4	SPV*	+5	+5
5	SP*	+5	+5
6	TM1*	+5	TM0*
7	AD1*	+5	AD0*
8	AD3*	-5.2	AD2*
9	AD5*	-5.2	AD4*
10	AD7*	-5.2	AD6*
11	AD9*	-5.2	AD8*
12	AD11*	GND	AD10*
13	AD13*	GND	AD12*
14	AD15*	GND	AD14*
15	AD17*	GND	AD16*
16	AD19*	GND	AD18*
17	AD21*	GND	AD20*
18	AD23*	GND	AD22*
19	AD25*	GND	AD24*
20	AD27*	GND	AD26*
21	AD29*	GND	AD28*
22	AD31*	GND	AD30*
23	GND	GND	GND
24	GND	-5.2	PFW*
25	ARB1*	-5.2	ARB0*
26	ARB3*	-5.2	ARB2*
27	ID1*	-5.2	ID0*
28	ID3*	+5	ID2*
29	ACK*	+5	START*
30	+5	GND	+5
31	RQST*	GND	+5
32	NMR*	+12	GND

Figure B-2. NuBus Pin Assignments

Trigger6	1	2	Digital GND
Trigger5	3	4	Digital GND
Trigger4	5	6	Digital GND
Trigger3	7	8	Digital GND
Trigger2	9	10	Digital GND
Trigger1	11	12	Digital GND
Trigger0	13	14	Digital GND
DMARQ0*	15	16	DMARQ1*
DMARQ2*	17	18	DMARQ3*
DMARQ5*	19	20	DMARQ6*
DMARQ7*	21	22	EDACK0
EDACK1	23	24	EDACK2
EOP*	25	26	INT0*
INT1*	27	28	INT2*
INT3*	29	30	INT4*
INT5*	31	32	INT6*
INT7*	33	34	Digital GND
RESERVED	35	36	RESERVED
CLKX2	37	38	CLKX1
TX2	39	40	TX1
FSX2	41	42	FSX1
GND	43	44	GND
CLKRX2	45	46	CLKRX1
FSR2	47	48	FSR1
RX2	49	50	RX1

Figure B-3. RTSI Bus Connector Pinout



# Appendix C

## AMD Data Sheet\*

---

This appendix contains the manufacturer data sheet for the Am9513A/Am9513 System Timing Controller (Advanced Micro Devices, Inc.) integrated circuit. This circuit is used on the NB-DMA2800.

**Data Sheets not available in electronic format.**

\* Copyright © Advanced Micro Devices, Inc. 1985 Reprinted with permission of copyright owner.  
All rights reserved.  
Advanced Micro Devices, Inc. 1985 Data Book *MOS Microprocessors and Peripherals*

# Appendix D

## Intel Data Sheet\*

---

This appendix contains the *82380 High Performance 32-bit DMA Controller with Integrated System Support Peripherals* (Intel Corporation) data sheet. This device is used on the NB-DMA2800.

**Data Sheets not available in electronic format.**

\* Copyright © Intel Corporation 1989 Reprinted with permission of copyright owner.  
All rights reserved.  
Intel Corporation 1989 Data Book *Microprocessor and Peripheral Handbook, Volume I Microprocessor*, 1990 Data Book *Microprocessors*.

# Appendix E

## Customer Communication

---

For your convenience, this appendix contains forms to help you gather the information necessary to help us solve technical problems you might have as well as a form you can use to comment on the product documentation. Filling out a copy of the *Technical Support Form* before contacting National Instruments helps us help you better and faster.

National Instruments provides comprehensive technical assistance around the world. In the U.S. and Canada, applications engineers are available Monday through Friday from 8:00 a.m. to 6:00 p.m. (central time). In other countries, contact the nearest branch office. You may fax questions to us at any time.

### Corporate Headquarters

(512) 795-8248

Technical support fax: (800) 328-2203  
(512) 794-5678

<b>Branch Offices</b>	<b>Phone Number</b>	<b>Fax Number</b>
Australia	(03) 879 9422	(03) 879 9179
Austria	(0662) 435986	(0662) 437010-19
Belgium	02/757.00.20	02/757.03.11
Denmark	45 76 26 00	45 76 71 11
Finland	(90) 527 2321	(90) 502 2930
France	(1) 48 14 24 00	(1) 48 14 24 14
Germany	089/741 31 30	089/714 60 35
Italy	02/48301892	02/48301915
Japan	(03) 3788-1921	(03) 3788-1923
Mexico	95 800 010 0793	95 800 010 0793
Netherlands	03480-33466	03480-30673
Norway	32-848400	32-848600
Singapore	2265886	2265887
Spain	(91) 640 0085	(91) 640 0533
Sweden	08-730 49 70	08-730 43 70
Switzerland	056/20 51 51	056/20 51 55
Taiwan	02 377 1200	02 737 4644
U.K.	0635 523545	0635 523154

# Technical Support Form

---

Photocopy this form and update it each time you make changes to your software or hardware, and use the completed copy of this form as a reference for your current configuration. Completing this form accurately before contacting National Instruments for technical support helps our applications engineers answer your questions more efficiently.

If you are using any National Instruments hardware or software products related to this problem, include the configuration forms from their user manuals. Include additional pages if necessary.

Name \_\_\_\_\_

Company \_\_\_\_\_

Address \_\_\_\_\_

\_\_\_\_\_

Fax (\_\_\_\_) \_\_\_\_\_ Phone (\_\_\_\_) \_\_\_\_\_

Computer brand \_\_\_\_\_ Model \_\_\_\_\_ Processor \_\_\_\_\_

Operating system \_\_\_\_\_

Speed \_\_\_\_\_MHz RAM \_\_\_\_\_MB Display adapter \_\_\_\_\_

Mouse \_\_\_\_\_yes \_\_\_\_\_no Other adapters installed \_\_\_\_\_

Hard disk capacity \_\_\_\_\_M Brand \_\_\_\_\_

Instruments used \_\_\_\_\_

National Instruments hardware product model \_\_\_\_\_ Revision \_\_\_\_\_

Configuration \_\_\_\_\_

National Instruments software product \_\_\_\_\_ Version \_\_\_\_\_

Configuration \_\_\_\_\_

The problem is \_\_\_\_\_

\_\_\_\_\_

\_\_\_\_\_

\_\_\_\_\_

\_\_\_\_\_

List any error messages \_\_\_\_\_

\_\_\_\_\_

\_\_\_\_\_

\_\_\_\_\_

\_\_\_\_\_

The following steps will reproduce the problem \_\_\_\_\_

\_\_\_\_\_

\_\_\_\_\_

# NB-DMA2800 Hardware and Software Configuration Form

---

Record the settings and revisions of your hardware and software on the line to the right of each item. Complete a new copy of this form each time you revise your software or hardware configuration, and use this form as a reference for your current configuration. Completing this form accurately before contacting National Instruments for technical support helps our applications engineers answer your questions more efficiently.

## National Instruments Products

- Revision Level of NB-DMA2800 \_\_\_\_\_
- Error Codes Returned by Diagnostics Software \_\_\_\_\_
- NI-DAQ Version \_\_\_\_\_
- Programming Language \_\_\_\_\_

## Other Products

- Computer Make and Model \_\_\_\_\_
- Amount of Memory \_\_\_\_\_
- Type of Video Board Installed \_\_\_\_\_
- System and Finder Versions \_\_\_\_\_
- Programming Language Version \_\_\_\_\_
- Other Boards in System \_\_\_\_\_
- Slots (Base I/O Addresses) of Other Boards \_\_\_\_\_

# Documentation Comment Form

---

National Instruments encourages you to comment on the documentation supplied with our products. This information helps us provide quality products to meet your needs.

Title: **NB-DMA2800 User Manual**

Edition Date: **November 1995**

Part Number: **320240B-01**

Please comment on the completeness, clarity, and organization of the manual.

---

---

---

---

---

---

---

---

If you find errors in the manual, please record the page numbers and describe the errors.

---

---

---

---

---

---

---

---

Thank you for your help.

Name \_\_\_\_\_

Title \_\_\_\_\_

Company \_\_\_\_\_

Address \_\_\_\_\_

\_\_\_\_\_

Phone ( \_\_\_\_\_ ) \_\_\_\_\_

Mail to: Technical Publications  
National Instruments Corporation  
6504 Bridge Point Parkway, MS 53-02  
Austin, TX 78730-5039

Fax to: Technical Publications  
National Instruments Corporation  
(512) 794-5678

# Glossary

---

Prefix	Meaning	Value
p-	pico-	10 <sup>-12</sup>
n-	nano-	10 <sup>-9</sup>
μ-	micro-	10 <sup>-6</sup>
m-	milli-	10 <sup>-3</sup>
k-	kilo-	10 <sup>3</sup>
M-	mega-	10 <sup>6</sup>

°	degree
%	percent
A	ampere
A/D	analog-to-digital
BCR	Board Control Register
C	Celsius
D/A	digital-to-analog
DAC	D/A converter
DMA	direct memory access
FIFO	first-in-first-out
hex	hexadecimal
Hz.	hertz
in.	inch
I/O	input/output
MB	megabytes of memory
NMR	nonmaskable interrupt request
PLA	Programmed Logic Array
ROM	read-only memory
RTSI	Real-Time System Integration
sec	second
TLC	Talker/Listener/Controller
V	volt
VI	virtual instrument
W	watt

# Index

---

## Numbers

- 82380 High-Performance 32-bit DMA Controller.  
*See* Intel 82380 High-Performance 32-bit DMA Controller.
- 82380 Register Group
  - calculating the proper offset for, 4-7, 4-24
  - register maps, 4-4 to 4-6

## A

- abbreviations used in the manual, vi
- addresses. *See* registers.
- Am9513A/AmZ8073A System Timing Controller
  - Alarm registers and Comparators, C-10
  - block diagram, C-2
  - bus width, C-12
  - characteristics, C-2
  - command descriptions, C-28 to C-31
  - Command register, C-7
  - command summary, C-29
  - Comparator enable option, C-11
  - connection diagram, C-3
  - Control port registers, C-7 to C-9
  - count control, C-27
  - count source selection, C-28
  - counter logic groups, C-6
  - Counter Mode
    - control options, C-25 to C-28
    - descriptions, C-13 to C-25
    - operating summary, C-13
  - Counter Mode register
    - bit assignments, C-26
    - description of, C-10
  - counter output waveforms, C-27
  - data bus assignments, C-5
  - Data Pointer register, C-7 to C-9
  - Data Pointer sequencing, C-9, C-12
  - Data Port registers, C-10
  - description, detailed, C-6 to C-7
  - description, general, C-2
  - FOUT divider, C-11
  - FOUT gate, C-11
  - FOUT source, C-11
  - frequency scaler ratios, C-12
  - gating control, C-12, C-28
  - hardware retriggering, C-28
  - Hold register, C-10



- input circuitry, C-5
- interface considerations, C-5
- load Data Pointer commands, C-9
- Load register, C-10
- master mode control options, C-10 to C-12
- Mode A waveforms, C-14
- Mode B waveforms, C-14 to C-15
- Mode C waveforms, C-15
- Mode D waveforms, C-16
- Mode E waveforms, C-16
- Mode F waveforms, C-17
- Mode G waveforms, C-17 to C-18
- Mode H waveforms, C-18
- Mode I waveforms, C-18 to C-19
- Mode J waveforms, C-19 to C-20
- Mode K waveforms, C-19 to C-20
- Mode L waveforms, C-20 to C-21
- Mode N waveforms, C-20 to C-21
- Mode O waveforms, C-21 to C-22
- Mode Q waveforms, C-22 to C-23
- Mode R waveforms, C-22 to C-23
- Mode S waveforms, C-23 to C-24
- Mode V waveforms, C-23 to C-24
- Mode X waveforms, C-25
- ordering information, C-3
- output control, C-25, C-27
- output control logic, C-26
- pin description, C-4
- power supply, C-7
- prefetch circuit, C-9
- register maps, 4-2
- scaler ratios, C-12
- specifications
  - absolute maximum ratings, C-32
  - bus transfer switching waveforms, C-35
  - counter switching waveforms, C-35
  - DC characteristics, C-32
  - operating ranges, C-32
  - switching characteristics, C-33 to C-34
  - switching test input/output waveforms, C-32
- status register, C-9 to C-10
- TC (terminal count), C-27
- time-of-day option, C-11
- timer and RTSI bus interface circuitry, 3-5

ATN\* bit, 4-21

## **B**

- Board Control Register, 4-10 to 4-11
- bus error handler
  - installation and programming considerations, 4-23 to 4-24

## **C**

- cables, connecting, 2-1 to 2-2
- CMD0 bit, 4-11
- CMD1 bit, 4-11
- configuration EPROM
  - description of, 4-22
  - NuBus slave interface circuitry, 3-3
- Configuration Register Group
  - Board Control Register, 4-10 to 4-11
  - EOP Interrupt Enable Register, 4-13
  - NuBus Block Mode Enable Register, 4-14
  - NuBus Flyby Enable Register, 4-15
  - NuBus MLock Enable Register, 4-16
  - overview, 4-9
  - register map, 4-2
  - Scan Circuitry Bypass Register, 4-12
- Counter/Timer, Am9513. *See* Am9513A Counter/Timer.
- customer support, *vi*

## D

- DAV\* bit, 4-21
- DIO\*<8..1> bit, 4-21
- DMA and NuBus master circuitry
  - block diagram, 3-3
  - description of, 3-3
- DMA Controller. *See* Intel 82380 High-Performance 32-bit DMA Controller.
- DMA interface programming
  - DMA request sources, 4-24
  - DMA transfer modes, 4-24
  - fetch-and-deposit (two-cycle) demand mode, 4-25
  - fetch-and-deposit (two-cycle) single-transfer mode, 4-25
  - multiple-channel DMA operations
    - bypassing the scan circuitry, 4-33 to 4-34
    - COMMAND field operations, 4-32
    - cyclic scanning, 4-31
    - DMARQ\*n and DREQn requests, 4-29
    - legal scan modes—COMMAND<1..0>=00, 4-31 to 4-32
    - LIMIT field, 4-32
    - overview, 4-29
    - parallel scanning, 4-31
    - scan circuitry, 4-29
    - using the scan circuitry, 4-33
  - NuBus block mode, 4-27
  - NuBus flyby (single-cycle) demand mode, 4-26 to 4-27
  - NuBus flyby (single-cycle) single-transfer mode, 4-26
  - single-channel DMA operations
    - DMA controller setup, 4-27
    - DMA termination, 4-28
    - DMA transfer operation, 4-28
    - overview, 4-27
- DMANMR\* bit, 4-11
- documentation

abbreviations used in the manual, *vi*  
organization of the manual, *v*  
related documents, *vi*

Don't Care bits. *See* X (Don't care bits).

DRAM refresh controller. *See* Intel 82380 High-Performance 32-bit DMA Controller.

DRQ4 bit, 4-11

## **E**

EIE\*<7..0> bit, 4-13

EOI\* bit, 4-21

EOP Interrupt Enable Register, 4-13

equipment, optional, 1-3

error-handling. *See* bus error handler.

## **F**

fetch-and-deposit (two-cycle) demand mode, 4-25

fetch-and-deposit (two-cycle) single-transfer mode, 4-25

## **G**

GPIB connector pinouts and signal names, B-1

GPIB data transfer rates, A-1

GPIB interface

block diagram for GPIB interface circuitry, 3-4

cable connections for, 2-1

circuitry for GPIB interface, 3-4

programming considerations, 4-37

Turbo488, 3-4

GPIB Register Group

GPIB Monitor Register, 4-21

overview, 4-20

register map, 4-3

## **H**

hardware installation, 2-1

## **I**

IEEE 488 (GPIB) interface. *See* GPIB interface.

IFC\* bit, 4-21

initializing the NB-DMA2800 board, 4-23

installation

bus error handler installation and programming considerations, 4-23 to 4-24

cable connection, 2-1 to 2-2

hardware installation, 2-1

hardware verification, 2-2 to 2-5

unpacking the NB-DMA2800, 1-4

Intel 82380 High-Performance 32-bit DMA Controller

- 80386 host interface, D-9
- 80386 interface signals, D-10
- address bus, D-11
- address pipelining, D-14
- address status, D-12
- architecture, D-3
- bus cycle definition signals, D-12
- bus timing, D-13 to D-17
- byte enable, D-11
- clock (CLK2), D-10
- CPU reset function, D-8
- data bus (D0-D31), D-10 to D-11
- definition of, D-2
- DMA controller
  - 8237A compatibility, D-49
  - arbitration of cascaded master requests, D-36 to D-38
  - arbitration of refresh requests, D-38
  - block diagram, D-18
  - block transfer mode, D-24
  - buffer auto-initialize process, D-22
  - buffer chaining process, D-23
  - buffer processes, D-41 to D-42
  - buffer transfer processes, D-22
  - bus arbitration and handshaking, D-31 to D-34
  - bus operation, D-30 to D-31
  - cascaded bus masters, D-42
  - channel priority arbitration, D-27 to D-28
  - Channel registers, D-39 to D-40
  - combining priority modes, D-29
  - Control/Status registers, D-38 to D-29
  - data path width and data transfer rate considerations, D-31
  - data transfer modes, D-23 to D-27, D-42
  - demand transfer mode, D-25 to D-27
  - description of, D-4 to D-5
  - DREQn and EDACK(0-2) signals, D-21
  - EOP # signal, D-21
  - fly-by transfers, D-30
  - functional description, D-19 to D-20
  - HOLD and HLDA signals, D-21
  - interface signals, D-20 to D-21
  - modes of operation, D-21 to D-22
- Intel 82380 High-Performance 32-bit DMA Controller
  - DMA controller (continued)
    - programming, D-41 to D-43
    - read, write, and verify cycles, D-31
    - register definitions, D-43 to D-49
    - register overview, D-38
    - single buffer process, D-22
    - single transfer mode, D-23 to D-24
    - software commands, D-42 to D-43
    - synchronous and asynchronous sampling, D-34 to D-36
    - target/requester definition, D-22
    - temporary registers, D-40
    - two-cycle transfers, D-30

- DRAM refresh controller
  - address decoding, D-94
  - arbitration, D-92
  - bus function, D-92
  - CPU reset and shutdown detection, D-94 to D-95
  - description of, D-7 to D-8
  - functional description, D-91
  - hardware reset, D-94
  - interface signals, D-91
  - modes of operation, D-93
  - programming, D-93
  - register bit definition, D-93
  - register set overview, D-93
  - relocation register and address decode, D-93 to D-94
  - shutdown detect, D-95
  - software reset, D-94 to D-95
  - TOUT1/REF# signal, D-91
  - word size and refresh address counter, D-93
- features, D-2
- functional overview, D-3 to D-9
- host interface, D-8
- IBM PC system compatibility, D-9
- Intel reserved I/O ports, D-96
- internal block diagram, D-2
- internal control and diagnostic ports
  - diagnostic ports, D-95
  - internal control port, D-95
- interrupt controller, D-6
- interrupt out, D-13
- master and slave modes, D-10
- master mode bus timing, D-14 to D-16
- mechanical data
  - A.C. specifications, D-105 to D-113
  - D.C. specifications, D-103 to D-104
  - electrical data, D-102 to D-113
  - ICE-386 support, D-102
  - introduction, D-96
  - maximum ratings, D-103
  - package dimensions and mounting, D-99 to D-101
  - package thermal specification, D-101 to D-102
  - pin assignment, D-97 to D-98
- Intel 82380 High-Performance 32-bit DMA Controller
  - mechanical data (continued)
    - power and grounding, D-102
    - power decoupling, D-102
    - unused pin recommendations, D-102
  - next address request, D-12
  - pin description, D-122
  - ports listed by address, D-114 to D-117
  - ports listed by function, D-118 to D-121
  - programmable interrupt controller (PIC)
    - automatic rotation–equal priority devices, D-56 to D-57
    - bus functional description, D-53 to D-54
    - edge or level interrupt triggering, D-58

- end-of-interrupt, D-54 to D-55
- functional description, D-50
- Initialization Command Words (ICW), D-61
- initialization (ICW), D-62 to D-63
- interface signals, D-52 to D-53
- internal block diagram, D-50
- interrupt cascading, D-58 to D-59
- interrupt controller banks, D-51 to D-52
- interrupt inputs, D-52 to D-53
- Interrupt Mask Register (IMR), D-62
- interrupt masking, D-58
- interrupt output, D-53
- interrupt priorities, D-55 to D-57
- interrupt priority mode summary, D-57
- mode of operation, D-54
- Operation Control Words (OCW), D-61 to D-62, D-63 to D-64
- poll command, D-59
- Poll/Interrupt Request/In-Service Status register, D-62, D-66 to D-67
- programming, D-62
- read status and poll commands (OCW3), D-63 to D-64
- reading interrupt registers, D-59
- reading interrupt status, D-59
- register bit definition, D-64 to D-66
- register operational summary, D-67
- register set overview, D-59 to D-60
- special fully nested mode, D-59
- specific rotation–specific priority, D-57
- Vector Register (VR), D-62
- Vector Registers (VR), D-63
- programmable interval timer
  - CLKIN signal, D-70
  - Control Word Register I & II, D-79
  - counter, D-78
  - Counter 0, 1, 2, 3 registers, D-79
  - functional description, D-68 to D-69
  - GATE input, D-78
  - GATE signal, D-70
  - initialization, D-79
  - interface signals, D-70
  - internal architecture, D-69 to D-70
  - Mode 1–gate retriggerable one-shot, D-71, D-73
  - Mode 5–gate retriggerable strobe, D-77 to D-78
  - Mode 4–initial count triggered strobe, D-76 to D-77
  - Mode 0–interrupt on terminal count, D-71 to D-72
  - Mode 2–rate generator, D-73 to D-74
  - Mode 3–square wave generator, D-74 to D-76
  - modes of operation, D-71 to D-79
  - operation common to all modes, D-78
  - overview, D-5
  - programming, D-79 to D-81
  - read operation, D-79 to D-81
  - register bit definitions, D-81 to D-83
  - register map, 4-7
  - register set overview, D-78 to D-79

- TOUT1, TOUT2#, TOUT3# signals, D-70
- register map relocation, D-8
- reset, D-12 to D-13
- slave mode bus timing, D-17
- transfer acknowledge, D-12
- wait state generator
  - application issues, D-89 to D-90
  - bus function, D-85 to D-88
  - description of, D-7
  - extending and early terminating bus cycle, D-87 to D-88
  - external 'ready' control logic, D-89 to D-90
  - functional description, D-83
  - interface signals, D-84
  - programming, D-89
  - READY# signal, D-84
  - READY0# signal, D-84
  - register bit definition, D-89
  - register set overview, D-88 to D-89
  - wait states in non-pipelined cycle, D-85 to D-86
  - wait states in pipelined cycle, D-86 to D-87
  - WSC(0-1) signal, D-84
- interrupts
  - programmable interrupt controller (PIC). *See Intel 82380 High-Performance 32-bit DMA Controller.*
  - RSTI bus interrupt interface programming considerations, 4-37
- interval timer, programmable. *See Intel 82380 High-Performance 32-bit DMA Controller.*

## L

- LabVIEW software, 1-3
- LIMA<2..0> bit, 4-11
- LIMB<2..0> bit, 4-11

## M

- $\mu$ PD7210 TLC interface
  - overview, 3-4
  - register map, 4-3
- MODEA bit, 4-11
- MODEB bit, 4-11
- multiple-channel DMA operations
  - bypassing the scan circuitry, 4-33 to 4-34
  - COMMAND field operations, 4-32
  - cyclic scanning, 4-31
  - DMARQ\*n and DREQn requests, 4-29
  - legal scan modes—COMMAND<1..0>=00, 4-31 to 4-32
  - LIMIT field, 4-32
  - overview, 4-29
  - parallel scanning, 4-31
  - scan circuitry, 4-29 to 4-31
  - using the scan circuitry, 4-33

**N**

- NB-DMA2800 board
  - block diagram, 3-1
  - contents of kit, 1-2
  - DMA and NuBus master circuitry, 3-3
  - functional overview, 3-1
  - GPIO interface circuitry, 3-4
  - illustration of, 1-2
  - NuBus slave interface circuitry, 3-2
  - optional equipment, 1-3
  - optional software, 1-3
  - overview and features, 1-1 to 1-2
  - specifications, A-1
  - timer and RTSI bus interface circuitry, 3-5
- NBE<7..0> bit, 4-14
- NDAC\* bit, 4-21
- NEC  $\mu$ PD7210 TLC interface. *See*  $\mu$ PD7210 TLC interface.
- NFE<7..0> bit, 4-15
- NI-DAQ software for Macintosh, 1-3
- NMLE<7..0> bit, 4-16
- NMRIE bit, 4-10
- NRFD\* bit, 4-21
- NuBus block mode, 4-27
- NuBus Block Mode Enable Register, 4-14
- NuBus Flyby Enable Register, 4-15
- NuBus flyby (single-cycle) demand mode, 4-26 to 4-27
- NuBus flyby (single-cycle) single-transfer mode, 4-26
- NuBus master circuitry. *See* DMA and NuBus master circuitry.
- NuBus MLock Enable Register, 4-16
- NuBus pin assignments, B-2
- NuBus RETRY. *See* bus error handler.
- NuBus slave interface circuitry
  - block diagram, 3-3
  - description of, 3-2
  - error handling requirements, 3-2
  - overview, 3-2

**O**

- offset for 82380 registers, calculating, 4-7, 4-24
- operating environment specifications, A-1

**P**

- physical specifications, A-1
- pin description
  - Am9513A/AmZ8073A System Timing Controller, C-4
  - GPIO connector, B-1
  - Intel 82380 High-Performance 32-bit DMA Controller, D-97 to D-98, D-122
  - NuBus pin assignments, B-2



- RTSI bus connector pinout, B-3
- power specifications, A-1
- programmable interrupt controller (PIC). *See* Intel 82380 High-Performance 32-bit DMA Controller.
- programmable interval timer. *See* Intel 82380 High-Performance 32-bit DMA Controller.
- programming. *See also* Intel 82380 High-Performance 32-bit DMA Controller; registers.
  - bus error handler installation, 4-23 to 4-24
  - DMA interface programming
    - DMA controller setup, 4-27
    - DMA request sources, 4-24
    - DMA termination, 4-28
    - DMA transfer modes, 4-24
    - DMA transfer operation, 4-28
    - fetch-and-deposit (two-cycle) demand mode, 4-25
    - fetch-and-deposit (two-cycle) single-transfer mode, 4-25
    - multiple-channel DMA operations, 4-29 to 4-34
    - NuBus block mode, 4-27
    - NuBus flyby (single-cycle) demand mode, 4-26 to 4-27
    - NuBus flyby (single-cycle) single-transfer mode, 4-26
    - single-channel DMA operations, 4-27
  - GPiB interface, 4-37
  - initializing the NB-DMA2800 board, 4-23
  - NB-DMA2800 programming components, 4-24
  - register programming considerations, 4-23
  - RSTI bus interrupt interface
    - 82380 external interrupt sources, 4-37
    - overview, 4-37
  - RTSI bus trigger interface
    - data used to configure trigger lines, 4-37
    - description of, 4-33 to 4-37
    - gating B<5> onto A<3> (illustration), 4-35
    - overview, 4-33
    - RTSI switch 1 trigger lines, 4-35
    - RTSI switch signals, 4-34
  - System Timing Controller interface
    - configuration, 4-38 to 4-39
    - overview, 4-38

## R

- register descriptions
  - configuration EPROM, 4-22
  - Configuration Register Group
    - Board Control Register, 4-10 to 4-11
    - EOP Interrupt Enable Register, 4-13
    - NuBus Block Mode Enable Register, 4-14
    - NuBus Flyby Enable Register, 4-15
    - NuBus MLock Enable Register, 4-16
    - overview, 4-9
    - Scan Circuitry Bypass Register, 4-12
  - format for descriptions, 4-8
  - GPiB Register Group
    - GPiB Monitor Register, 4-21

- overview, 4-20
- overview, 4-8
- RTSI Switch Register Group
  - overview, 4-17
  - RTSI Switch Shift Registers, 4-18
  - RTSI Switch Strobe Registers, 4-19
- register maps
  - 82380 Register Group, 4-4 to 4-6
  - Am9513A System Timing Controller Register Group, 4-2
  - Configuration Register Group, 4-2
  - GPiB Interface Register Group, 4-3
  - GPiB Monitor Register, 4-3
  - μPD7210 TLC interface, 4-3
  - overview, 4-2
  - Programmable Interval Timer Register Group, 4-7
  - RTSI Switch Register Group, 4-2
  - Software Command Register Group, 4-6
  - Turbo488 Register Group, 4-3
- registers
  - programming considerations, 4-23
  - register access, 4-1
  - slot address space, 4-1
  - word sizes, 4-4
- REN\* bit, 4-21
- RSI bit, 4-18
- RTSI bus
  - cables for optional equipment, 1-3
  - connector pinout, B-3
  - timer and RTSI bus interface circuitry, 3-5
- RTSI bus interrupt interface, programming
  - 82380 external interrupt sources, 4-37
  - overview, 4-37
- RTSI bus trigger interface, programming
  - data used to configure trigger lines, 4-37
  - description of, 4-33 to 4-37
  - gating B<5> onto A<3> (illustration), 4-35
  - overview, 4-33
  - RTSI switch 1 trigger lines, 4-35
  - RTSI switch signals, 4-34
- RTSI Switch Register Group
  - overview, 4-17
  - register map, 4-2
  - RTSI Switch Shift Registers, 4-18
  - RTSI Switch Strobe Registers, 4-19
- RTSI bit, 4-10

## S

- scan circuitry. *See* multiple-channel DMA operations.
- Scan Circuitry Bypass Register, 4-12
- SCB<7..0> bit, 4-12
- single-channel DMA operations
  - DMA controller setup, 4-27
  - DMA termination, 4-28

- DMA transfer operation, 4-28
  - overview, 4-27
- slot address space, 4-1
- software, optional, 1-3
- Software Command Register Group, register map for, 4-6
- specifications
  - Am9513A/AmZ8073A System Timing Controller, C-32 to C-35
  - Intel 82380 High-Performance 32-bit DMA Controller, D-96 to D-113
  - NB-DMA2800 interface board, A-1
- SRQ\* bit, 4-21
- storage environment specifications, A-1
- System Timing Controller interface, programming. *See also* Am9513A/AmZ8073A System Timing Controller; Intel 82380 High-Performance 32-bit DMA Controller.
  - configuration, 4-38 to 4-39
  - overview, 4-38

## T

- TDMA0 bit, 4-10
- TDMA5 bit, 4-10
- TDMA6 bit, 4-10
- technical support, *vi*
- theory of operation
  - DMA and NuBus master circuitry, 3-3
  - functional overview, 3-1
  - GPIB interface circuitry, 3-4
  - NuBus slave interface circuitry, 3-2
  - timer and RTSI bus interface circuitry, 3-5
- timer. *See* Am9513A/AmZ8073A System Timing Controller; Intel 82380 High-Performance 32-bit DMA Controller.
- transfer modes, DMA. *See* DMA interface programming.
- Turbo488 GPIB interface, 3-4
- Turbo488 Register Group, register map for, 4-3

## U

- unpacking the NB-DMA2800, 1-4

## W

- wait state generator. *See* Intel 82380 High-Performance 32-bit DMA Controller.
- word sizes for registers, 4-4

## X

- X (Don't care bits), 4-11, 4-16, 4-18