

IMAQ[™]

NI 1450 Series Compact Vision System User Manual

Worldwide Technical Support and Product Information

ni.com

National Instruments Corporate Headquarters

11500 North Mopac Expressway Austin, Texas 78759-3504 USA Tel: 512 683 0100

Worldwide Offices

Australia 1800 300 800, Austria 43 0 662 45 79 90 0, Belgium 32 0 2 757 00 20, Brazil 55 11 3262 3599,
Canada (Calgary) 403 274 9391, Canada (Montreal) 514 288 5722, Canada (Ottawa) 613 233 5949,
Canada (Québec) 514 694 8521, Canada (Toronto) 905 785 0085, Canada (Vancouver) 514 685 7530,
China 86 21 6555 7838, Czech Republic 420 2 2423 5774, Denmark 45 45 76 26 00,
Finland 385 0 9 725 725 11, France 33 0 1 48 14 24 24, Germany 49 0 89 741 31 30, Greece 30 2 10 42 96 427,
India 91 80 51190000, Israel 972 0 3 6393737, Italy 39 02 413091, Japan 81 3 5472 2970,
Korea 82 02 3451 3400, Malaysia 603 9131 0918, Mexico 001 800 010 0793, Netherlands 31 0 348 433 466,
New Zealand 1800 300 800, Norway 47 0 66 90 76 60, Poland 48 0 22 3390 150, Portugal 351 210 311 210,
Russia 7 095 238 7139, Singapore 65 6226 5886, Slovenia 386 3 425 4200, South Africa 27 0 11 805 8197,
Spain 34 91 640 0085, Sweden 46 0 8 587 895 00, Switzerland 41 56 200 51 51, Taiwan 886 2 2528 7227,
Thailand 662 992 7519, United Kingdom 44 0 1635 523545

For further support information, refer to the *Technical Support and Professional Services* appendix. To comment on the documentation, send email to techpubs@ni.com.

© 2003 National Instruments Corporation. All rights reserved.

Important Information

Warranty

The NI 1450 Series Compact Vision System is warranted against defects in materials and workmanship for a period of one year from the date of shipment, as evidenced by receipts or other documentation. National Instruments will, at its option, repair or replace equipment that proves to be defective during the warranty period. This warranty includes parts and labor.

The media on which you receive National Instruments software are warranted not to fail to execute programming instructions, due to defects in materials and workmanship, for a period of 90 days from date of shipment, as evidenced by receipts or other documentation. National Instruments will, at its option, repair or replace software media that do not execute programming instructions if National Instruments receives notice of such defects during the warranty period. National Instruments does not warrant that the operation of the software shall be uninterrupted or error free.

A Return Material Authorization (RMA) number must be obtained from the factory and clearly marked on the outside of the package before any equipment will be accepted for warranty work. National Instruments will pay the shipping costs of returning to the owner parts which are covered by warranty.

National Instruments believes that the information in this document is accurate. The document has been carefully reviewed for technical accuracy. In the event that technical or typographical errors exist, National Instruments reserves the right to make changes to subsequent editions of this document without prior notice to holders of this edition. The reader should consult National Instruments if errors are suspected. In no event shall National Instruments be liable for any damages arising out of or related to this document or the information contained in it.

EXCEPT AS SPECIFIED HEREIN, NATIONAL INSTRUMENTS MAKES NO WARRANTIES, EXPRESS OR IMPLIED, AND SPECIFICALLY DISCLAIMS ANY WARRANTY OF MERCHANTABILITY OR FITNESS FOR A PARTICULAR PURPOSE. CUSTOMER'S RIGHT TO RECOVER DAMAGES CAUSED BY FAULT OR NEGLIGENCE ON THE PART OF NATIONAL INSTRUMENTS SHALL BE LIMITED TO THE AMOUNT THEREOF PAID BY THE CUSTOMER. NATIONAL INSTRUMENTS WILL NOT BE LIABLE FOR DAMAGES RESULTING FROM LOSS OF DATA, PROFITS, USE OF PRODUCTS, OR INCIDENTAL OR CONSEQUENTIAL DAMAGES, EVEN IF ADVISED OF THE POSSIBILITY THEREOF. This limitation of the liability of National Instruments will apply regardless of the form of action, whether in contract or tort, including negligence. Any action against National Instruments must be brought within one year after the cause of action accrues. National Instruments shall not be liable for any delay in performance due to causes beyond its reasonable control. The warranty provided herein does not cover damages, defects, malfunctions, or service failures caused by owner's failure to follow the National Instruments installation, operation, or maintenance instructions; owner's modification of the product; owner's abuse, misuse, or negligent acts; and power failure or surges, fire, flood, accident, actions of third parties, or other events outside reasonable control.

Copyright

Under the copyright laws, this publication may not be reproduced or transmitted in any form, electronic or mechanical, including photocopying, recording, storing in an information retrieval system, or translating, in whole or in part, without the prior written consent of National Instruments Corporation.

Trademarks

IMAQ™, LabVIEW™, National Instruments™, NI™, ni.com™, NI Developer Zone™, and NI-IMAQ™ are trademarks of National Instruments Corporation.

Product and company names mentioned herein are trademarks or trade names of their respective companies.

Patents

For patents covering National Instruments products, refer to the appropriate location: **Help»Patents** in your software, the `patents.txt` file on your CD, or ni.com/patents.

WARNING REGARDING USE OF NATIONAL INSTRUMENTS PRODUCTS

(1) NATIONAL INSTRUMENTS PRODUCTS ARE NOT DESIGNED WITH COMPONENTS AND TESTING FOR A LEVEL OF RELIABILITY SUITABLE FOR USE IN OR IN CONNECTION WITH SURGICAL IMPLANTS OR AS CRITICAL COMPONENTS IN ANY LIFE SUPPORT SYSTEMS WHOSE FAILURE TO PERFORM CAN REASONABLY BE EXPECTED TO CAUSE SIGNIFICANT INJURY TO A HUMAN.

(2) IN ANY APPLICATION, INCLUDING THE ABOVE, RELIABILITY OF OPERATION OF THE SOFTWARE PRODUCTS CAN BE IMPAIRED BY ADVERSE FACTORS, INCLUDING BUT NOT LIMITED TO FLUCTUATIONS IN ELECTRICAL POWER SUPPLY, COMPUTER HARDWARE MALFUNCTIONS, COMPUTER OPERATING SYSTEM SOFTWARE FITNESS, FITNESS OF COMPILERS AND DEVELOPMENT SOFTWARE USED TO DEVELOP AN APPLICATION, INSTALLATION ERRORS, SOFTWARE AND HARDWARE COMPATIBILITY PROBLEMS, MALFUNCTIONS OR FAILURES OF ELECTRONIC MONITORING OR CONTROL DEVICES, TRANSIENT FAILURES OF ELECTRONIC SYSTEMS (HARDWARE AND/OR SOFTWARE), UNANTICIPATED USES OR MISUSES, OR ERRORS ON THE PART OF THE USER OR APPLICATIONS DESIGNER (ADVERSE FACTORS SUCH AS THESE ARE HEREAFTER COLLECTIVELY TERMED "SYSTEM FAILURES"). ANY APPLICATION WHERE A SYSTEM FAILURE WOULD CREATE A RISK OF HARM TO PROPERTY OR PERSONS (INCLUDING THE RISK OF BODILY INJURY AND DEATH) SHOULD NOT BE RELIANT SOLELY UPON ONE FORM OF ELECTRONIC SYSTEM DUE TO THE RISK OF SYSTEM FAILURE. TO AVOID DAMAGE, INJURY, OR DEATH, THE USER OR APPLICATION DESIGNER MUST TAKE REASONABLY PRUDENT STEPS TO PROTECT AGAINST SYSTEM FAILURES, INCLUDING BUT NOT LIMITED TO BACK-UP OR SHUT DOWN MECHANISMS. BECAUSE EACH END-USER SYSTEM IS CUSTOMIZED AND DIFFERS FROM NATIONAL INSTRUMENTS' TESTING PLATFORMS AND BECAUSE A USER OR APPLICATION DESIGNER MAY USE NATIONAL INSTRUMENTS PRODUCTS IN COMBINATION WITH OTHER PRODUCTS IN A MANNER NOT EVALUATED OR CONTEMPLATED BY NATIONAL INSTRUMENTS, THE USER OR APPLICATION DESIGNER IS ULTIMATELY RESPONSIBLE FOR VERIFYING AND VALIDATING THE SUITABILITY OF NATIONAL INSTRUMENTS PRODUCTS WHENEVER NATIONAL INSTRUMENTS PRODUCTS ARE INCORPORATED IN A SYSTEM OR APPLICATION, INCLUDING, WITHOUT LIMITATION, THE APPROPRIATE DESIGN, PROCESS AND SAFETY LEVEL OF SUCH SYSTEM OR APPLICATION.

Compliance

FCC/Canada Radio Frequency Interference Compliance

Determining FCC Class

The Federal Communications Commission (FCC) has rules to protect wireless communications from interference. The FCC places digital electronics into two classes. These classes are known as Class A (for use in industrial-commercial locations only) or Class B (for use in residential or commercial locations). All National Instruments (NI) products are FCC Class A products.

Depending on where it is operated, this Class A product could be subject to restrictions in the FCC rules. (In Canada, the Department of Communications (DOC), of Industry Canada, regulates wireless interference in much the same way.) Digital electronics emit weak signals during normal operation that can affect radio, television, or other wireless products.

All Class A products display a simple warning statement of one paragraph in length regarding interference and undesired operation. The FCC rules have restrictions regarding the locations where FCC Class A products can be operated.

Consult the FCC Web site at www.fcc.gov for more information.

FCC/DOC Warnings

This equipment generates and uses radio frequency energy and, if not installed and used in strict accordance with the instructions in this manual and the CE marking Declaration of Conformity*, may cause interference to radio and television reception. Classification requirements are the same for the Federal Communications Commission (FCC) and the Canadian Department of Communications (DOC).

Changes or modifications not expressly approved by NI could void the user's authority to operate the equipment under the FCC Rules.

Class A

Federal Communications Commission

This equipment has been tested and found to comply with the limits for a Class A digital device, pursuant to part 15 of the FCC Rules. These limits are designed to provide reasonable protection against harmful interference when the equipment is operated in a commercial environment. This equipment generates, uses, and can radiate radio frequency energy and, if not installed and used in accordance with the instruction manual, may cause harmful interference to radio communications. Operation of this equipment in a residential area is likely to cause harmful interference in which case the user is required to correct the interference at their own expense.

Canadian Department of Communications

This Class A digital apparatus meets all requirements of the Canadian Interference-Causing Equipment Regulations.

Cet appareil numérique de la classe A respecte toutes les exigences du Règlement sur le matériel brouilleur du Canada.

Compliance to EU Directives

Readers in the European Union (EU) must refer to the manufacturer's Declaration of Conformity (DoC) for information* pertaining to the CE marking compliance scheme. The manufacturer includes a DoC for most hardware products except for those bought from OEMs. In addition, DoCs are usually not provided if compliance is not required, for example electrically benign apparatus or cables.

To obtain the DoC for this product, click **Declarations of Conformity Information** at ni.com/hardref.nsf/. This Web site lists the DoCs by product family. Select the appropriate product family, followed by your product, and a link to the DoC appears in Adobe Acrobat format. Click the Acrobat icon to download or read the DoC.

* The CE marking Declaration of Conformity contains important supplementary information and instructions for the user or installer.

Conventions

The following conventions are used in this manual:

»

The » symbol leads you through nested menu items and dialog box options to a final action. The sequence **File»Page Setup»Options** directs you to pull down the **File** menu, select the **Page Setup** item, and select **Options** from the last dialog box.



This icon denotes a tip, which alerts you to advisory information.



This icon denotes a note, which alerts you to important information.



This icon denotes a caution, which advises you of precautions to take to avoid injury, data loss, or a system crash.

bold

Bold text denotes items that you must select or click in the software, such as menu items and dialog box options. Bold text also denotes hardware labels and parameter names.

italic

Italic text denotes variables, emphasis, a cross reference, or an introduction to a key concept. This font also denotes text that is a placeholder for a word or value that you must supply.

`monospace`

Text in this font denotes text or characters that you should enter from the keyboard, sections of code, programming examples, and syntax examples. This font is also used for the proper names of disk drives, paths, directories, programs, subprograms, subroutines, device names, functions, operations, variables, filenames and extensions, and code excerpts.

`monospace bold`

Bold text in this font denotes the messages and responses that the computer automatically prints to the screen. This font also emphasizes lines of code that are different from the other examples.

Contents

Chapter 1

NI 1450 Overview

About the NI 1450 Series Compact Vision System.....	1-1
Hardware Overview	1-1
Available Camera Bandwidth.....	1-3
Software Overview	1-4
NI-IMAQ for IEEE 1394 Cameras Driver Software.....	1-4
National Instruments Application Software	1-5
Vision Builder for Automated Inspection	1-5
LabVIEW RT with the Vision Development Module	1-5

Chapter 2

Setup and Configuration

Required Items	2-1
Hardware	2-1
Software.....	2-2
Accessories	2-2
Hardware	2-2
Documentation	2-3
Hardware Documents	2-3
Vision Builder AI Documents	2-3
LabVIEW Real-Time Module with the Vision Development Module	
Documents	2-3
NI-IMAQ for IEEE 1394 Cameras Driver Software Documents	2-3
LabVIEW Real-Time Module and Vision Development Module	
Documents.....	2-4
Safety Information	2-4
Connection Overview	2-6
Before Getting Started: Connecting the NI 1450 to a Network	2-7
Subnet Considerations.....	2-8
Hardware Setup	2-8
Connecting a Camera and Monitor to the NI 1450.....	2-8
Wiring Power to the NI 1450.....	2-9
Connecting the NI 1450 to the Development Computer.....	2-11
Vision Builder AI: Setting up the Development Computer.....	2-12
Installing Vision Builder AI and NI-IMAQ for IEEE 1394 Cameras.....	2-13
Configuring the IP Address and Downloading Software onto the NI 1450....	2-13
Acquiring an Image in Vision Builder AI	2-14

LabVIEW Real-Time with the Vision Development Module: Setting up the
 Development Computer..... 2-15
 Installing LabVIEW Real-Time, Vision Development Module,
 and NI-IMAQ for IEEE 1394 Cameras 2-15
 Configuring the IP Address using LabVIEW Real-Time 2-16
 Downloading Software onto the NI 1450 2-17
 Acquiring an Image Using LabVIEW Real-Time 2-17

Chapter 3 LEDs, DIP Switches, and Connectors

LED Indicators 3-1
 POWER OK LED 3-2
 STATUS LED 3-2
 ACT/LINK LED 3-2
 100 Mbps LED 3-2
 DIP Switches 3-3
 SAFE MODE Switch 3-4
 IP RESET Switch 3-5
 NO APP Switch 3-5
 USER 1 Switch (LabVIEW RT Users) 3-5
 Connectors 3-6
 Power Connector 3-6
 Earth Ground Connection 3-7
 IEEE 1394 3-8
 VGA 3-8
 COM1 3-10
 Ethernet 3-11
 TRIG 0 3-11
 TRIG 1 and TRIG 2 3-11
 General-Purpose Digital I/O 3-11

Chapter 4 Digital I/O Functionality

Overview 4-1
 TTL Inputs and Outputs 4-2
 Isolated Inputs and Outputs 4-2
 Trigger Inputs 4-3
 Timed Pulse Output 4-4
 Initiating a Timed Pulse 4-4
 Pulse Modes 4-5
 Pulse Delay 4-5

Pulse Width	4-5
Trigger Polarity	4-5
Quadrature Encoder.....	4-6
Product Selection Port	4-7
Using ISO Input 5 as a Latch	4-7
General-Purpose I/O.....	4-8
General-Purpose Inputs.....	4-8
General-Purpose Outputs	4-8
Fault Conditions	4-9
Shutdown	4-9
Disabling Shutdown Mode.....	4-10
Watchdog.....	4-10
Overheat	4-11
Considerations When Connecting the Digital I/O.....	4-11
Wiring an Isolated Input to a Sourcing Output Device.....	4-11
Wiring an Isolated Output to an External Load	4-12
Protecting Inductive Loads	4-13
Transmission Line Effects	4-13
Typical System Setup	4-14

Chapter 5 Deployment

Connecting Multiple NI 1450s	5-1
------------------------------------	-----

Appendix A Troubleshooting

Appendix B Specifications

Appendix C Technical Support and Professional Services

Glossary

Index

NI 1450 Overview

This chapter provides an overview of the features and components on the National Instruments 1450 Series Compact Vision System.

About the NI 1450 Series Compact Vision System

The NI 1450 Series Compact Vision System is an easy-to-use, distributed, real-time imaging system that acquires, processes, and displays images from IEEE 1394 cameras conforming to the *IIDC 1394-based Digital Camera Specification, Version 1.30*. The NI 1450 also provides multiple digital input/output (I/O) options for communicating with external devices to configure and start an inspection and to indicate results.

An Ethernet connection between the NI 1450 and a development computer allows you to display measurement results and status information and to configure the NI 1450 settings. Once configured, the NI 1450 can run applications without a connection to the development computer.

Each NI 1450 ships with documentation and the NI-IMAQ for IEEE 1394 Cameras driver software, which is licensed for one development system and one deployment system.

Hardware Overview

The NI 1450 front panel consists of a VGA connector, an RS-232 serial port, a 10/100 Ethernet connector, and three IEEE 1394a ports.

The NI 1450 also includes LEDs for communicating system status, DIP switches for mode control for specifying startup options, TTL inputs and outputs for triggering, and isolated inputs and outputs for connecting to external devices, such as PLCs, sensors, LED indicators, and start/stop buttons. The isolated inputs and outputs on the NI 1450 provide an easy means for preventing ground loops that could degrade signal integrity.



Caution The isolation on the NI 1450 is *not* safety isolation.

Figure 1-1 shows the NI 1450 front panel.

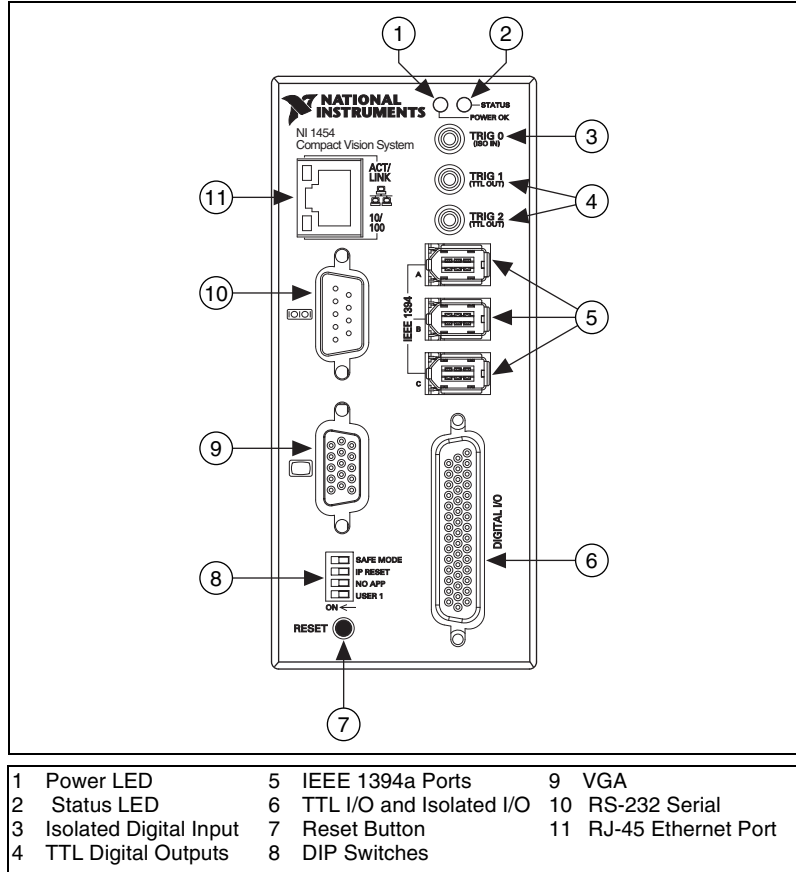

Figure 1-1. NI 1450 Series Compact Vision System Front Panel

Available Camera Bandwidth

The IEEE 1394 bus provides a fixed amount of bandwidth that is shared among the three IEEE 1394a ports on the NI 1450. These ports provide direct connection to up to three DCAM-compliant IEEE 1394 cameras, depending on the amount of bandwidth each camera requires. Higher frame rates and larger image sizes require a higher data transfer rate and use more bandwidth.

Table 1-1 shows the maximum number of cameras the NI 1450 supports for three common video formats. Use this table as a guide when determining the combination of cameras to use in your application. The maximum number of cameras listed in the table does not include processing time.

By triggering your cameras slower than the frame rates listed in the table, you can operate more cameras simultaneously. If the camera combination exceeds the amount of available bandwidth, the software returns an Insufficient Resources error.

Table 1-1. Available Camera Bandwidth

Video Format	Frames per Second	Maximum Number of Cameras for Simultaneous Operation
640 x 480, 8-bit/pixel mono	30	3
	60	1
	100	1
640 x 480 YUV (4:2:2) 16-bit/pixel color	15	3
	30	1
1024 x 768 16-bit/pixel mono	7.5	2
	15	1

Software Overview

Programming the NI 1450 Series Compact Vision System requires the NI-IMAQ for IEEE 1394 Cameras driver software, version 1.5 or later, to control the hardware and one of the following application software packages to process images.

- **NI Vision Builder for Automated Inspection (AI), version 2.0 or later**—To configure solutions to common inspection tasks
- **LabVIEW Real-Time (RT), version 7.0 or later, with the Vision Development Module, version 7.0 or later**—For customizable control over acquisition hardware and algorithms

The following sections provide an overview of the driver software and the application software. For detailed information about individual software packages, refer to the documentation specific to the package.

NI-IMAQ for IEEE 1394 Cameras Driver Software

The NI-IMAQ for IEEE 1394 Cameras driver software ships with the NI 1450 Series Compact Vision System. NI-IMAQ for IEEE 1394 Cameras is the interface path between the application software and the NI 1450.

NI-IMAQ for IEEE 1394 Cameras includes an extensive library of VIs you can call from LabVIEW. These VIs include routines for video configuration, image acquisition (continuous and single-shot), trigger control, and register-level camera configuration.

The NI-IMAQ for IEEE 1394 Cameras driver software performs all functions necessary for acquiring and saving images but does not perform image analysis. For image analysis functionality, refer to the [National Instruments Application Software](#) section.

For maximum flexibility and performance, NI-IMAQ for IEEE 1394 Cameras features both high-level and low-level functions. A function that acquires images in multi-buffer, single-shot, or continuous mode is an example of a high-level function. A function that requires advanced understanding of the NI 1450 and image acquisition, such as configuring an image sequence, is an example of a low-level function.

The NI-IMAQ for IEEE 1394 Cameras software handles many of the complex issues between the NI 1450 and the camera, such as 1394 bus communication and camera control.

National Instruments Application Software

Vision Builder for Automated Inspection

National Instruments Vision Builder for Automated Inspection (AI) is configurable machine vision software that you can use to prototype, benchmark, and deploy applications. NI Vision Builder AI does not require programming, but is scalable to LabVIEW RT.

Vision Builder AI allows you to easily configure and benchmark a sequence of visual inspection steps, as well as deploy the visual inspection system for automated inspection. With Vision Builder AI, you can perform powerful visual inspection tasks and make decisions based on the results of individual tasks. Additionally, you can communicate with external devices using an Ethernet connection, serial lines, and digital I/Os. With Vision Builder AI, you can migrate your configured inspection to LabVIEW, extending the capabilities of your applications if necessary.

LabVIEW RT with the Vision Development Module

The LabVIEW Real-Time Module and the RT Series hardware, such as the NI 1450, extend the capabilities of LabVIEW to address the need for deterministic real-time performance.

The Real-Time Module combines LabVIEW graphical programming with the power of RT Series hardware, enabling you to build deterministic real-time systems. You develop VIs in LabVIEW and embed the VIs on RT targets. The RT target runs VIs without a user interface and offers a stable platform for real-time VIs.

For more information about LabVIEW RT, refer to the *LabVIEW Real-Time Module User Manual*.

The Vision Development Module is an image acquisition, processing, and analysis library of more than 270 functions for grayscale, color, and binary image display, image processing, pattern matching, particle analysis, gauging, and measurement.

For unique image processing, you can use the Vision Development Module functions individually or in combination. The Vision Development Module allows you to acquire, display, manipulate, and store images as well as perform image analysis, processing, and interpretation. Using the Vision Development Module, imaging novices and experts can program the most basic or complicated image applications without knowledge of particular algorithm implementations.

Vision Assistant is an interactive prototyping tool for machine vision and scientific imaging developers and is included with the Vision Development Module. With Vision Assistant, you can prototype vision applications quickly and test how various vision image processing functions work.

For information about how to use the Vision Development Module with LabVIEW RT, refer to the *IMAQ Vision for LabVIEW User Manual*.

Setup and Configuration

This chapter provides instructions for connecting the NI 1450 Series Compact Vision System hardware. This chapter also includes instructions for installing software, configuring an IP address, and acquiring an initial image using the application software.

Required Items

The following items are necessary for connecting the NI 1450.

Hardware

- NI 1450 Series Compact Vision System
- Ethernet-equipped development computer running Windows XP/2000/Me/98
- DCAM-compliant IEEE 1394 camera
- IEEE 1394 jackscrew-to-latch cable (part number 778796-01) or any standard IEEE 1394 cable—for plug-and-play connection from the NI 1450 to up to three 1394 cameras. You can use a 4-pin to 6-pin converter cable with cameras that have their own external power supply and do not require power from the 1394 bus.



Note To maintain signal integrity, the IEEE 1394 cable length must be no longer than 4.5 m.

- NI desktop power supply (part number 778794-01) or any 24 VDC $\pm 10\%$, 50 W power supply
- Power supply cord—for connecting the NI desktop power supply to an outlet. Refer to ni.com for ordering information for the part number specific to your region.



Note If you are using the NI desktop power supply, you will need a power cord.

- 4-position power connector—required if you are not using the NI desktop power supply
- 10 m 10/100Base-T Ethernet cable (part number 189174-10)—standard CAT 5 10/100Base-T Ethernet cable for connecting the NI 1450 to a network port. To connect the NI 1450 directly to a local development computer, use an Ethernet crossover cable.



Note To maintain signal integrity, the Ethernet cable length must be no longer than 100 m.

Software

- NI-IMAQ for IEEE 1394 Cameras driver software, which includes the NI 1450 support software
- One of the following application software packages:
 - National Instruments Vision Builder for Automated Inspection (AI), version 2.0 or later
 - National Instruments LabVIEW Real-Time, version 7.0 or later, with the Vision Development Module, version 7.0 or later

Accessories

National Instruments offers the following accessories for use with the NI 1450.

Hardware

- VGA-resolution camera (part number 778785-01)
- 12 mm fixed focal length lens (part number 778789-01)
- LED ring light (part number 778787-01)
- DIN rail/panel mount kit (part number 189154-01)
- Digital I/O cable and horizontal DIN rail terminal block (part number 778790-01)

- Digital I/O cable and vertical DIN rail terminal block (part number 778791-01)
- 75 Ω SMB 111 coaxial cable (part number 763422-01)—SMB to BNC cable for connecting to triggers and light sources
- 10 m Ethernet crossover cable (part number 187375-10)—for connecting the NI 1450 directly to the development computer

Documentation

The documentation resources listed in this section ship with the NI 1450 and the application software. For more resources, including code examples and tutorials, visit the National Instruments Developer Zone at ni.com/zone.

Hardware Documents

- *NI 1450 Series Compact Vision System User Manual*
- *NI 1450 Series Compact Vision System Digital I/O Help*

Vision Builder AI Documents

- *NI Vision Builder for Automated Inspection Tutorial*
- *NI Vision Builder for Automated Inspection: Configuration Help*
- *NI Vision Builder for Automated Inspection: Inspection Help*

LabVIEW Real-Time Module with the Vision Development Module Documents

NI-IMAQ for IEEE 1394 Cameras Driver Software Documents

- *Getting Started with NI-IMAQ for IEEE 1394 Cameras*
- *NI-IMAQ for IEEE 1394 Cameras User Manual (PDF)*
- *NI-IMAQ for IEEE 1394 Cameras VI Reference Help*
- *MAX Help for NI-IMAQ for IEEE 1394 Cameras*

LabVIEW Real-Time Module and Vision Development Module Documents

- *NI Vision Assistant Help*
- *NI Vision Assistant Tutorial*
- *IMAQ Vision Concepts Manual*
- *IMAQ Vision for LabVIEW User Manual*
- *IMAQ Vision for LabVIEW Help*
- LabVIEW Real-Time Module documentation

Safety Information



Caution The following paragraphs contain important safety information you *must* follow when installing and operating the device.

Do *not* operate the device in a manner not specified in the documentation. Misuse of the device may result in a hazard and may compromise the safety protection built into the device. If the device is damaged, turn it off and do *not* use it until service-trained personnel can check its safety. If necessary, return the device to National Instruments for repair.

Keep away from live circuits. Do *not* remove equipment covers or shields unless you are trained to do so. If signal wires are connected to the device, hazardous voltages can exist even when the equipment is turned off. To avoid a shock hazard, do *not* perform procedures involving cover or shield removal unless you are qualified to do so. Disconnect all field power prior to removing covers or shields.

If the device is rated for use with hazardous voltages ($>30 V_{\text{rms}}$, $42.4 V_{\text{pk}}$, or $60 V_{\text{dc}}$), it may require a safety earth-ground connection wire. Refer to the device specifications for maximum voltage ratings.

Because of the danger of introducing additional hazards, do *not* install unauthorized parts or modify the device. Use the device only with the chassis, modules, accessories, and cables specified in the installation instructions. All covers and filler panels must be installed while operating the device.

Do *not* operate the device in an explosive atmosphere or where flammable gases or fumes may be present. Operate the device only at or below the pollution degree stated in the specifications. Pollution consists of any

foreign matter—solid, liquid, or gas—that may reduce dielectric strength or surface resistivity. Pollution degrees are listed below.

- Pollution Degree 1—No pollution or only dry, nonconductive pollution occurs. The pollution has no effect.
- Pollution Degree 2—Normally only nonconductive pollution occurs. Occasionally, nonconductive pollution becomes conductive because of condensation.
- Pollution Degree 3—Conductive pollution or dry, nonconductive pollution occurs. Nonconductive pollution becomes conductive because of condensation.

Clean the device and accessories by brushing off light dust with a soft, nonmetallic brush. Remove other contaminants with a stiff, nonmetallic brush. The unit *must* be completely dry and free from contaminants before returning it to service.

You *must* insulate signal connections for the maximum voltage for which the device is rated. Do *not* exceed the maximum ratings for the device. Remove power from signal lines before connection to or disconnection from the device.



Caution National Instruments measurement products may be classified as either Installation Category I or II. Operate products at or below the Installation Category level specified in the hardware specifications.

Installation Category¹: Measurement circuits are subjected to working voltages² and transient stresses (overvoltage) from the circuit to which they are connected during measurement or test. Installation Category establishes standardized impulse withstand voltage levels that commonly occur in electrical distribution systems. The following is a description of Installation (Measurement³) Categories:

- Installation Category I is for measurements performed on circuits *not* directly connected to the electrical distribution system referred to as MAINS⁴ voltage. This category is for measurements of voltages from specially protected secondary circuits. Such voltage measurements include signal levels, special equipment, limited-energy parts of

¹ Installation Categories as defined in electrical safety standard IEC 61010-1.

² Working voltage is the highest rms value of an AC or DC voltage that can occur across any particular insulation.

³ Installation Category is also referred to as Measurement Category.

⁴ MAINS is defined as the (hazardous live) electrical supply system to which equipment is designed to be connected for the purpose of powering the equipment. Suitably rated measuring circuits may be connected to the MAINS for measuring purposes.

equipment, circuits powered by regulated low-voltage sources, and electronics.

- Installation Category II is for measurements performed on circuits directly connected to the electrical distribution system. This category refers to local-level electrical distribution, such as that provided by a standard wall outlet (e.g., 115 V for U.S. or 230 V for Europe). Examples of Installation Category II are measurements performed on household appliances, portable tools, and similar products.
- Installation Category III is for measurements performed in the building installation at the distribution level. This category refers to measurements on hard-wired equipment such as equipment in fixed installations, distribution boards, and circuit breakers. Other examples are wiring, including cables, bus-bars, junction boxes, switches, socket-outlets in the fixed installation, and stationary motors with permanent connections to fixed installations.
- Installation Category IV is for measurements performed at the primary electrical supply installation (<1,000 V). Examples include electricity meters and measurements on primary overcurrent protection devices and on ripple control units.

Connection Overview

Figure 2-1 illustrates the sequence for connecting and getting started with the NI 1450.

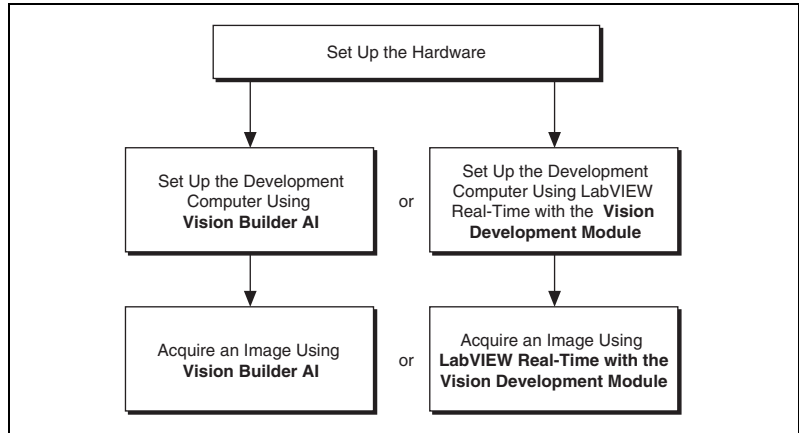

Figure 2-1. Connection Sequence

- **Set up the hardware**—This section explains how to connect a camera, monitor, and power supply to the NI 1450.
- **Set up the development computer**—This section explains how to use either Vision Builder AI or LabVIEW Real-Time with the Vision Development Module to perform the following tasks:
 - Connect the NI 1450 to the development computer
 - Install application and driver software
 - Obtain an IP address
- **Acquire an image**—This section explains how to use either Vision Builder AI or LabVIEW Real-Time with the Vision Development Module to acquire an image.

Before Getting Started: Connecting the NI 1450 to a Network

Use a standard Category 5 or Category 6 Ethernet cable to connect the NI 1450 to an Ethernet network.

If the development computer is already configured on a network, you must configure the NI 1450 on the same network. If the development computer is not connected to a network, you can connect the two directly using a Category 5 or Category 6 crossover cable.



Caution To prevent data loss and to maintain the integrity of your Ethernet installation, do *not* use a cable longer than 100 m. If you are using a 100 Mbps Ethernet, National Instruments recommends using a Category 5 or Category 6 shielded twisted-pair Ethernet cable.

Subnet Considerations

To configure the NI 1450, it must reside on the same subnet as the development computer. Once the NI 1450 is configured, other subnets can access and use it.

To use the NI 1450 on a subnet other than the one the development computer is on, first connect and configure it on the same subnet as the development computer. Next, physically move it to the other subnet and reassign an IP address. Contact your network administrator for assistance in setting up the development computer and NI 1450 on the same subnet.

Hardware Setup

This section describes how to connect the basic hardware components of the NI 1450. When these basic components are connected for the first time, the NI 1450 runs a program that acquires images. This program verifies that all hardware components are properly connected and functioning.

The following items are necessary for hardware setup.

- NI 1450 Series Compact Vision System
- 24 VDC $\pm 10\%$, 50 W power supply
- DCAM-compatible IEEE 1394 camera
- IEEE 1394 cable
- Ethernet cable
- Monitor

Connecting a Camera and Monitor to the NI 1450

Before connecting a camera and monitor to the NI 1450, make sure that all NI 1450 DIP switches are in the **OFF** position.

To connect an IEEE 1394 camera and a monitor to the NI 1450, refer to Figure 2-2 while completing the following steps:

1. Connect the VGA cable from the monitor to the VGA port on the NI 1450.
2. Plug the IEEE 1394 cable into one of the IEEE 1394a ports on the NI 1450. Plug the other end of the cable into the IEEE 1394 receptacle on the camera.

If your camera requires an external power supply, connect it to the camera and verify that the camera is powered on.

3. Plug in and power on the monitor.

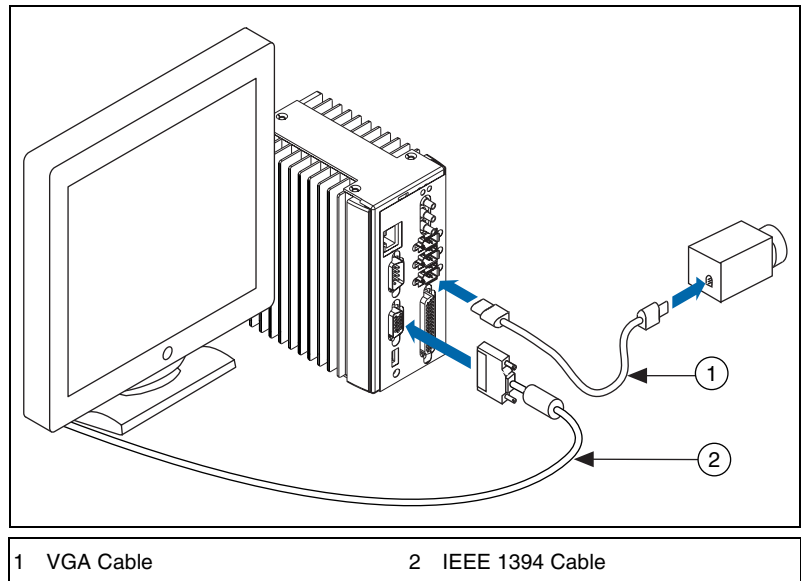

Figure 2-2. Basic Hardware Setup

Wiring Power to the NI 1450

This section describes how to connect the NI desktop power supply. For instructions on how to connect a separate main supply, refer to the [Connecting to a Separate Main Supply](#) section.



Caution Do *not* connect the NI 1450 main power to a source other than 24 VDC $\pm 10\%$. Do *not* connect the NI 1450 isolated power to a source less than 5 VDC or greater than 30 VDC. Doing so could damage the NI 1450.

To connect power to the NI 1450, refer to Figure 2-3 while completing the following steps:

1. Plug the 4-position connector from the power supply into the power receptacle on the NI 1450.
2. Plug the power cord into the power supply.
3. Plug the power cord into an outlet.

The NI 1450 ships with a factory-installed startup program that, when the NI 1450 is connected to a camera and powered on, acquires images and displays them on the monitor. If these images from the camera display on the monitor, continue to the [Connecting the NI 1450 to the Development Computer](#) section. If the images from the camera are not displayed on the monitor, refer to Appendix A, [Troubleshooting](#).

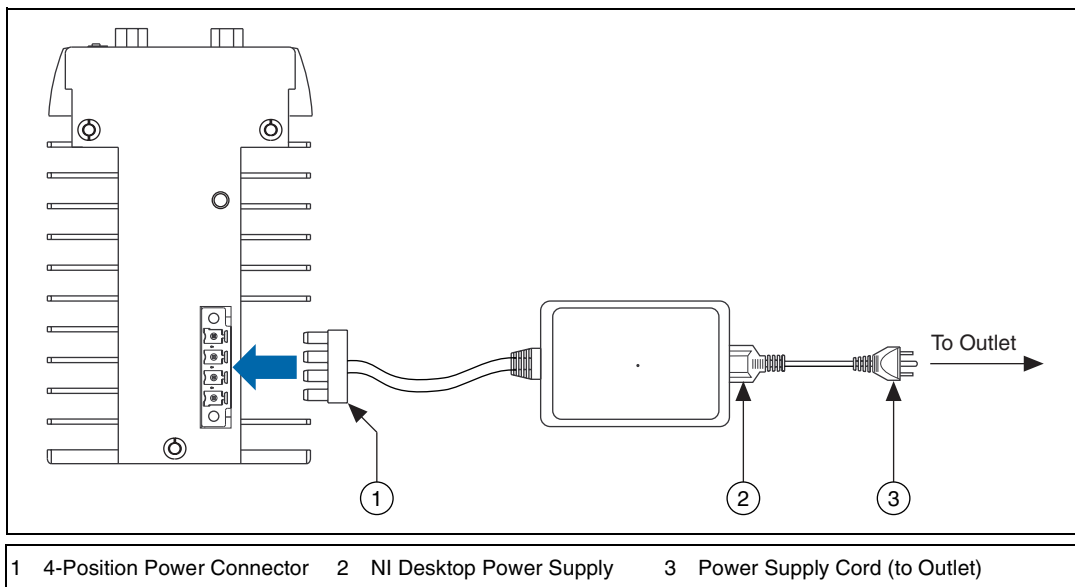

Figure 2-3. Wiring Power to the NI 1450

Connecting to a Separate Main Supply

If you are using a power supply other than the NI desktop power supply, use this section to connect power to the NI 1450.



Caution Do *not* connect the NI 1450 main power to a source other than 24 VDC $\pm 10\%$. Do *not* connect the NI 1450 isolated power to a source less than 5 VDC or greater than 30 VDC. Doing so could damage the NI 1450.

The NI 1450 ships with a 4-position power connector that plugs directly into the power input connector on the NI 1450. To wire power to the 4-position connector, complete the following steps:

1. Wire the voltage output of the 24 VDC $\pm 10\%$ power supply to the main voltage input, labeled **V**, on the 4-position connector.
2. Wire the common (ground) output of the power supply to the common input, labeled **C**, on the 4-position connector.

If you are using a separate power supply for the NI 1450 isolated outputs, connect the voltage output on the power supply to the isolated power (**Viso**) on the 4-position connector. Connect the common (ground) on the power supply to the isolated common (**Ciso**) on the connector.



Note If you do not require a separate power supply for the NI 1450 isolated outputs, you can daisy-chain the **V** to the **Viso** and the **C** to the **Ciso** on the connector.

For information about grounding the NI 1450 chassis to earth ground, refer to the [Earth Ground Connection](#) section of Chapter 3, [LEDs, DIP Switches, and Connectors](#).

Connecting the NI 1450 to the Development Computer

The development computer communicates with the NI 1450 over an Ethernet connection. Use a standard Ethernet cable to connect from the network port to the NI 1450. To connect the NI 1450 directly to the development computer, use an Ethernet crossover cable.

To connect the NI 1450 to the development computer, refer to Figure 2-4 while completing the following steps:

1. Verify that the development computer is connected to the network and is powered on.
2. Using a standard CAT 5 Ethernet cable, connect from the network port to the Ethernet port on the NI 1450.
3. Using a standard CAT 5 Ethernet cable, connect from the network port to the Ethernet port on the development computer.



Note If you are *not* connecting through a network, use an Ethernet crossover cable to connect the NI 1450 directly to the development computer.

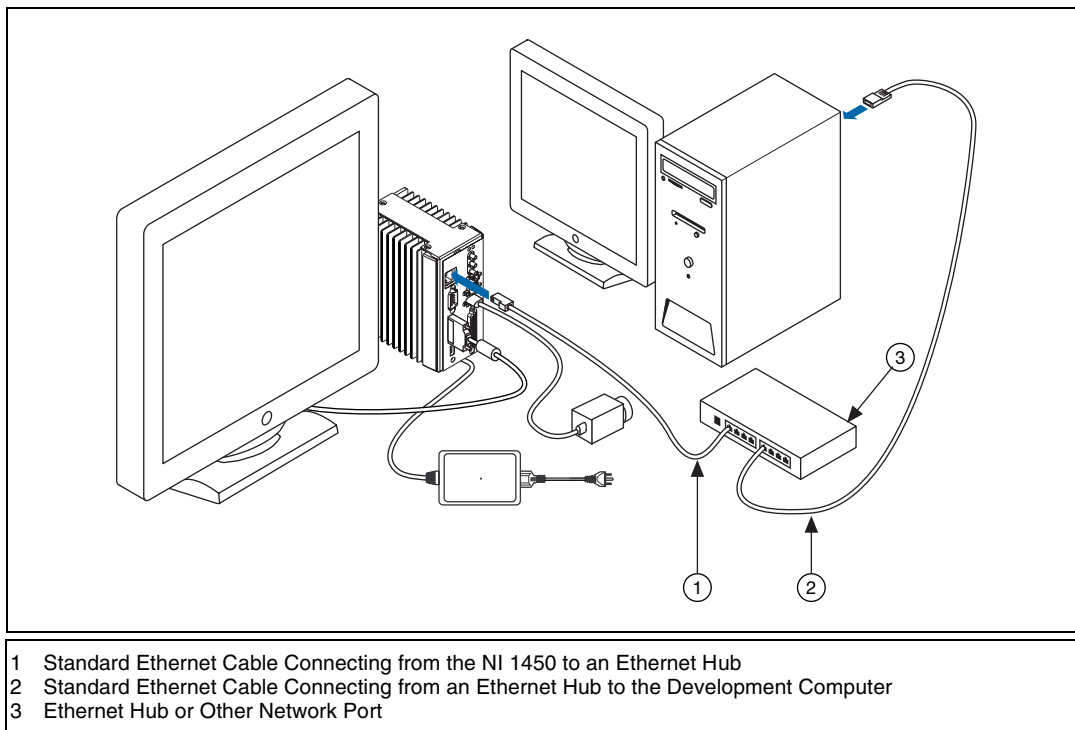

Figure 2-4. Ethernet Connection

Vision Builder AI: Setting up the Development Computer

This section describes the sequence for installing Vision Builder AI and the NI-IMAQ for IEEE 1394 Cameras software on the development computer, obtaining an IP address, installing software on the NI 1450, and configuring the NI 1450 to acquire an image using Vision Builder AI.

This section applies *only* to Vision Builder AI users. If you are using LabVIEW RT with the Vision Development Module, refer to the [LabVIEW Real-Time with the Vision Development Module: Setting up the Development Computer](#) section.

The following items are necessary for setting up the development computer.

- Vision Builder AI software, version 2.0 or later
- NI-IMAQ for IEEE 1394 Cameras driver software, version 1.5 or later

Installing Vision Builder AI and NI-IMAQ for IEEE 1394 Cameras

This section describes how to install the Vision Builder AI software and the NI-IMAQ for IEEE 1394 Cameras driver software onto the development computer.



Note You must install Vision Builder AI *before* installing the NI-IMAQ for IEEE 1394 Cameras driver software.

Complete the following steps to install Vision Builder AI and the NI-IMAQ for IEEE 1394 Cameras driver software onto the development computer.

1. Insert the Vision Builder AI CD into the CD-ROM drive.
2. When the installation splash screen appears, click **Install NI Vision Builder AI 2.0** and follow the setup instructions.
3. Insert the NI-IMAQ for IEEE 1394 Cameras CD into the CD-ROM drive.



Note When installing NI-IMAQ for IEEE 1394 Cameras, make sure to install the support files for LabVIEW Real-Time.

4. When the installation splash screen appears, click **Install NI-IMAQ for IEEE 1394 Cameras** and follow the setup instructions.
5. Reboot the development computer.

Configuring the IP Address and Downloading Software onto the NI 1450

To set up an IP address and download software onto the NI 1450, complete the following steps:

1. Launch Vision Builder AI by navigating to **Start»Programs»National Instruments»Vision Builder AI**.
2. Expand the **Execution Target** pull-down listbox and click **Select Network Target**. This process takes several seconds.
3. In the Select Remote Target window, click **192.168.10.12** to highlight the row. This IP address is assigned to all unconfigured NI 1450s.



Tip To uniquely identify unconfigured NI 1450s, connect and configure one NI 1450 at a time.

4. Click **Configure** to launch the Vision Builder AI Remote Target Configuration Wizard.
5. In the Identification window, enter a name for the NI 1450 in the **Name** field and a description of the NI 1450 in the **Description** field.



Note Device names are limited to 15 characters with no spaces or special characters. The first and last characters must be alphanumeric.

6. Click **Next**.
7. If the network is configured to issue IP addresses using DHCP, select **Obtain IP address from DHCP server**. Otherwise, set the IP address manually by selecting **Edit IP Settings, Suggest Values**, and **OK**.
8. Click **Next**. This window shows the status of the software installed on the NI 1450.
9. Select the **Update Target Software** checkbox.
10. Click **OK** to begin configuring the IP address and downloading software onto the NI 1450. This initialization process takes several minutes.

Acquiring an Image in Vision Builder AI

To acquire an image in Vision Builder AI, complete the following steps:

1. Launch Vision Builder AI.
2. In the Vision Builder AI Welcome screen, expand the **Execution Target** pull-down listbox and click **Select Network Target**.
3. Select the NI 1450 you configured and click **OK**.
4. In the Vision Builder AI Welcome screen, click **Configure Inspection**.
5. From the Acquire Images palette, click **Acquire Image (IEEE 1394)**.
6. Click the Snap button to acquire a single image, or click the Grab button to acquire continuous images.
7. Once you have configured your acquisition, click **OK** to add the step. You can now add inspection steps as documented in the *NI Vision Builder for Automated Inspection Tutorial*.



LabVIEW Real-Time with the Vision Development Module: Setting up the Development Computer

This section describes the sequence for installing the application and driver software on the development computer, obtaining an IP address, installing software on the NI 1450, and configuring the NI 1450 to acquire an image using LabVIEW Real-Time.

This section applies *only* to LabVIEW Real-Time users. If you are using the Vision Builder AI software, refer to the [Vision Builder AI: Setting up the Development Computer](#) section.

The following items are necessary for setting up the development computer.

- LabVIEW and LabVIEW Real-Time software
- Vision Development Module software
- NI-IMAQ for IEEE 1394 Cameras driver software

Installing LabVIEW Real-Time, Vision Development Module, and NI-IMAQ for IEEE 1394 Cameras



Note You must install LabVIEW, LabVIEW Real-Time, and the Vision Development Module software *before* installing the NI-IMAQ for IEEE 1394 Cameras driver software.

Complete the following steps to install LabVIEW, LabVIEW Real-Time, the Vision Development Module, and the NI-IMAQ for IEEE 1394 Cameras software onto the development computer.

1. Insert the LabVIEW CD into the CD-ROM drive.
2. When the installation splash screen appears, click **Install LabVIEW** and follow the setup instructions.
3. Insert the LabVIEW Real-Time CD into the CD-ROM drive.
4. When the installation splash screen appears, click **Install LabVIEW Real-Time** and follow the setup instructions.
5. Insert the Vision Development Module CD into the CD-ROM drive.
6. When the splash screen appears, click **Install Vision 7.0 Development Module** and follow the setup instructions.

7. Insert the NI-IMAQ for IEEE 1394 Cameras CD into the CD-ROM drive.



Note If you select the custom software installation, make sure to install the support for the NI 1450 Series Compact Vision System.

8. When the splash screen appears, click **Install NI-IMAQ for IEEE 1394 Cameras** and follow the setup instructions.
9. When prompted, click **Yes** to reboot the development computer.

Configuring the IP Address using LabVIEW Real-Time

To set up an IP address for the NI 1450, complete the following steps:



1. Open the Measurement & Automation Explorer (MAX) configuration software by double-clicking the MAX icon on the desktop, or navigate to it by selecting **Start>Programs>National Instruments>Measurement & Automation**.
2. Expand the **Remote Systems** branch of the configuration tree, and click **192.168.10.12** to display the Network Settings window. This IP address is assigned to all unconfigured NI 1450s.



Tip To uniquely identify unconfigured NI 1450s, connect and configure one NI 1450 at a time.

3. In the Network Settings window, enter a name for the device in the **Name** field and a description of the device in the **Comment** field.



Note Device names are limited to 15 characters with no spaces or special characters. The first and last characters must be alphanumeric.

4. If the network is configured to issue IP addresses using DHCP, select **Obtain IP address from DHCP server**. Otherwise, set the IP address manually by selecting **Edit the IP settings, Suggest Values**, and **OK**.
5. Click **Apply**.
6. When prompted, click **Yes** to reboot the NI 1450. This initialization process takes several minutes.

While the NI 1450 is rebooting, an icon  appears next to the device name to indicate that the NI 1450 is disconnected. The MAX status bar also indicates the connection status of the NI 1450.

Downloading Software onto the NI 1450

1. In the MAX configuration window, click the **Software** tab. This window displays the status of the software on the NI 1450.
2. Click the **Install Software** button.
3. Select the software to download. For initial installation, make sure all checkboxes are selected.
4. Click **OK**.
5. When prompted, click **Yes** to reboot the NI 1450. This process takes several seconds.

Acquiring an Image Using LabVIEW Real-Time

To acquire an image using LabVIEW Real-Time, complete the following steps:

1. Launch LabVIEW by navigating to **Start»Programs»National Instruments LabVIEW 7.0**.
2. Expand the **Execution Target** pull-down listbox and click **Select Target with Options**.
3. Enter the new IP address in the **Machine Name/IP** field and click **OK**.
4. Click the **Open** button.
5. Navigate to `Program Files\National Instruments\LabVIEW 7.0\examples\IMAQ`.
6. Double-click `IMAQ1394 examples.llb` and select `Grab.vi`.
7. Click the Run button to begin acquiring images.



Now that you are acquiring images in LabVIEW, you can use the Vision Development Module and the installed NI 1450 drivers to process images and to control inputs and outputs.

POWER OK LED

Under normal operating conditions, the **POWER OK** LED remains green while the NI 1450 is powered on. A green **POWER OK** LED indicates that NI 1450 main power is receiving power and that the NI 1450 is not in a fault state. A red **POWER OK** LED indicates that the NI 1450 has shut down because of a fault state. A fault state occurs when the user shutdown input is asserted, the processor overheats, or the watchdog timer expires.



Note The **POWER OK** LED does *not* indicate the status of the isolated power, Viso.

STATUS LED

The orange **STATUS** LED remains off under normal operating conditions and flashes a specific number of times to indicate error conditions or certain DIP switch settings. The **STATUS** LED remains lit if the NI 1450 detects an internal error.

Refer to the [Hardware Errors](#) section of Appendix A, [Troubleshooting](#), for information about LED error indications.

ACT/LINK LED

The orange **ACT/LINK** LED blinks when the NI 1450 receives data from or transmits data to the network through the Ethernet connection. Unrelated network activity causes this LED to blink occasionally even when the NI 1450 is inactive.

Figure 3-2 shows the location of the **ACT/LINK** LED on the NI 1450.

100 Mbps LED

The green **100 Mbps** LED is lit when the network provides 100 Mbps support and the NI 1450 is communicating at 100 Mbps. If the **100 Mbps** LED is not lit, the NI 1450 is not operating at 100 Mbps.

Figure 3-2 shows the location of the **100 Mbps** LED on the NI 1450.

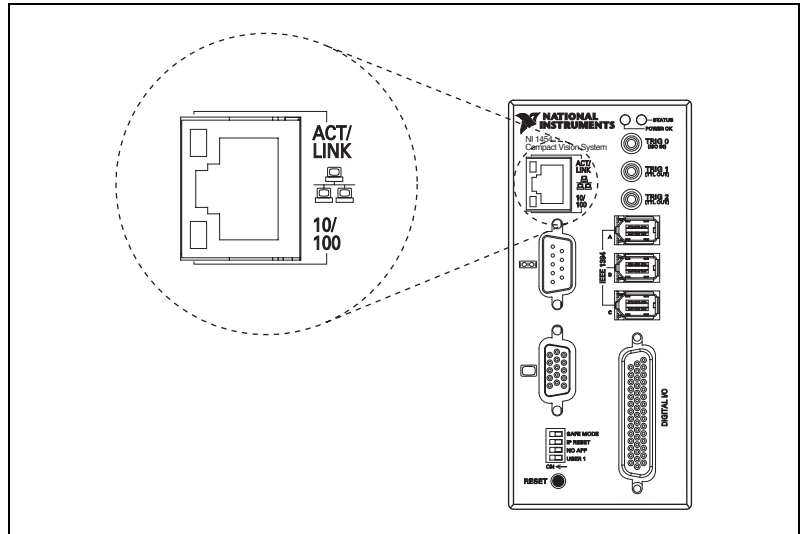

Figure 3-2. ACT/LINK and 100 Mbps LEDs

DIP Switches

This section describes the **SAFE MODE**, **IP RESET**, **NO APP**, and **USER 1** DIP switches on the NI 1450.

To enable a DIP switch, move it to the **ON** (left) position and then reset the NI 1450 by pressing the **RESET** button for at least two seconds.



Note You must reset the NI 1450 in order for the setting change to occur.

Figure 3-3 shows the location of the DIP switches on the NI 1450.

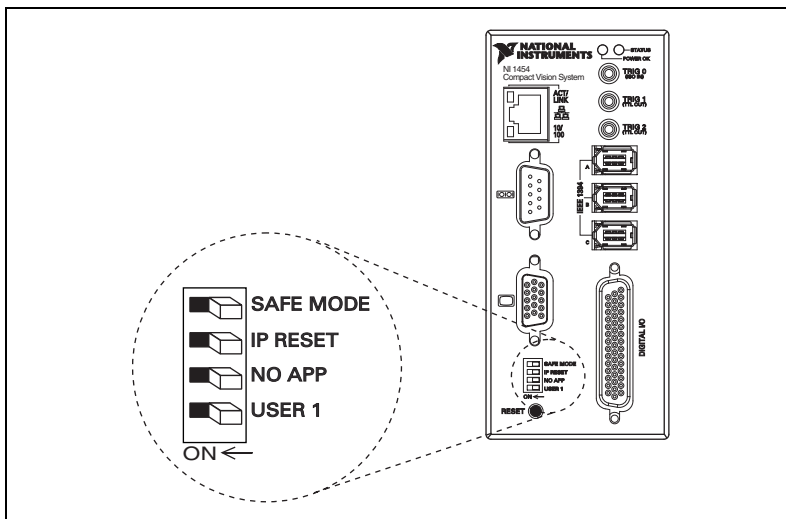
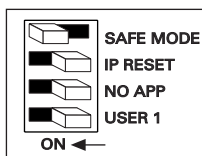

Figure 3-3. DIP Switches

SAFE MODE Switch



To boot the NI 1450 in Safe mode, move the **SAFE MODE** switch to the **ON** position and reset the NI 1450. Use safe mode to reconfigure TCP/IP settings and to download or update software from the development computer.

Downloading incorrect software to the NI 1450 may cause it to hang on reboot or become inaccessible over the network. Powering on or resetting the NI 1450 in **SAFE MODE** starts the NI 1450 but does not start the embedded LabVIEW RT engine. To resume normal operations, reboot the NI 1450 with the **SAFE MODE** switch in the **OFF** position.

IP RESET Switch

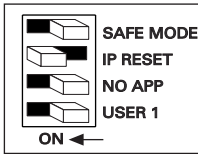

To clear the NI 1450 IP settings, move the **IP RESET** switch to the **ON** position and reset the NI 1450. Use **IP RESET** to reset the TCP/IP settings when moving the system from one subnet to another or when the current TCP/IP settings are invalid.

Resetting the NI 1450 with the **IP RESET** switch in the **ON** position resets the IP address to **0.0.0.0**. You can then set up a new network configuration for the NI 1450 from a development machine on the same subnet, or you can use an Ethernet crossover cable to connect the NI 1450 directly to the development computer.

NO APP Switch

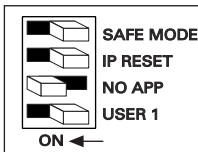

To prevent the NI 1450 from automatically running VIs at startup, move the **NO APP** switch to the **ON** position and reset the NI 1450. If the NI 1450 becomes inaccessible because of a startup program, enable the **NO APP** switch and reset the NI 1450.

Enable this switch to prevent the NI 1450 default startup program or Vision Builder AI from running at startup.

USER 1 Switch (LabVIEW RT Users)

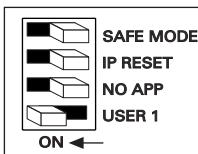

The **USER 1** switch is user-configurable and has no default functionality. You can use the RT Read Switch VI to read the **USER 1** switch state and perform a custom action based on the current switch state position.

Connectors

This section describes the connectors on the NI 1450 and includes pinouts and signal descriptions for each connector.

Table 3-1 summarizes the functions of the connectors on the NI 1450.

Table 3-1. NI 1450 Connectors Overview

Peripheral	External Connectors	Function
Power	4-position power connector	Main power and power for isolated outputs
IEEE 1394a	6-pin IEEE 1394	Power and data connection to IEEE 1394 cameras
VGA	15-pin female DSUB (standard VGA)	Video output
Serial	9-pin male DSUB (standard RS-232 serial port)	COM1
10/100 Ethernet	RJ-45 (standard Ethernet port)	Ethernet network connection
TRIG 0	SMB receptacle	External isolated trigger input
TRIG 1 and TRIG 2	SMB receptacle	External TTL output
Digital Input/Output	44-pin female high-density DSUB	External TTL I/O; External isolated I/O

Power Connector

The power connector on the NI 1450 accommodates two power supplies. The terminals labeled **V** and **C** provide the voltage and common for the main power of the NI 1450. The terminals labeled **Viso** and **Ciso** provide the voltage and common to power the isolated output circuitry.



Caution The isolation provided by the NI 1450 is intended to prevent ground loops that could introduce noise into the system. This isolation does *not* provide safety isolation.

Figure 3-4 shows the power connector on the NI 1450, and Table 3-2 describes each terminal on the connector.

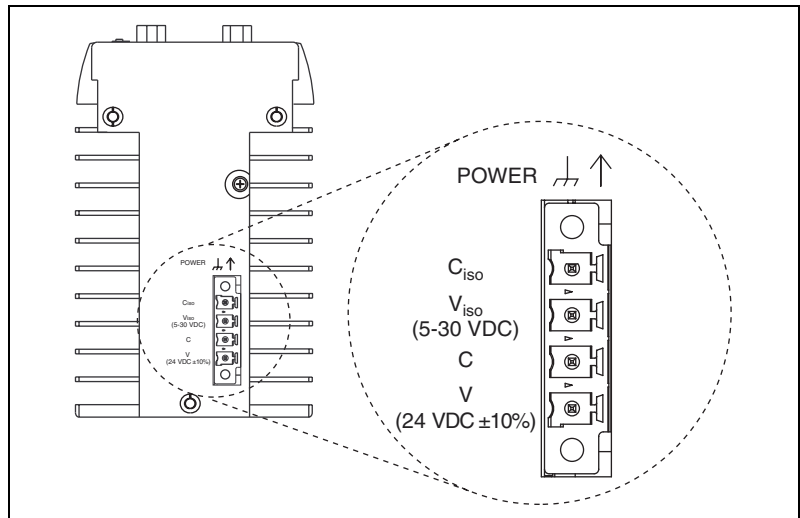

Figure 3-4. Power Connector

Table 3-2. Power Connector Terminals

Terminal	Description
V	Main power (24 VDC \pm 10%)
C	Common
Viso	Isolated power (5 to 30 VDC)
Ciso	Isolated common

Earth Ground Connection

Some system setups may require using the grounding lug on the NI 1450 to connect the chassis to earth ground. Connecting the grounding lug, shown in Figure 3-5, to earth ground connects the common of the main power to earth ground through the NI 1450 chassis.



Note An earth ground connection does *not* connect Ciso to earth ground.

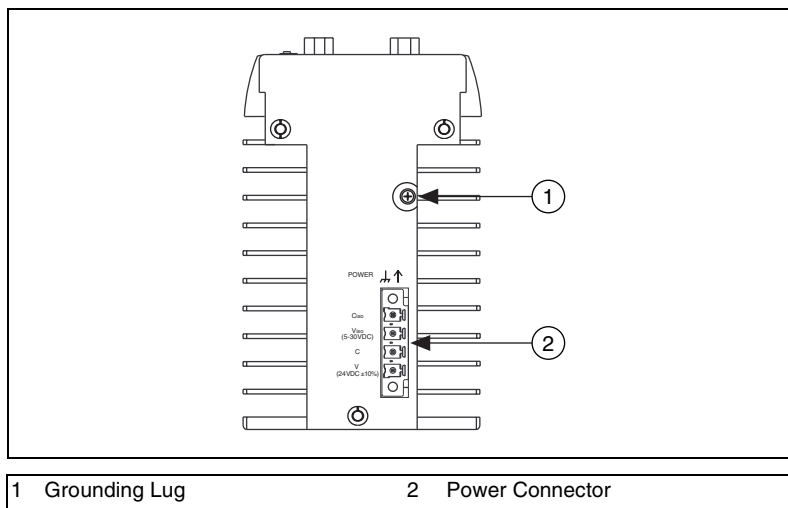

Figure 3-5. Grounding Lug on the NI 1450

IEEE 1394

The IEEE 1394 connectors on the NI 1450 provide a reliable, high-frequency connection between the NI 1450 and up to three DCAM-compatible IEEE 1394 cameras. For information about the amount of bandwidth available for connecting cameras, refer to the [Available Camera Bandwidth](#) section of Chapter 1, *NI 1450 Overview*.

To access the IEEE 1394 connectors on the NI 1450, use any standard 6-pin IEEE 1394 cable.



Note You can use a 4-pin to 6-pin converter cable with cameras that have their own external power supply and do not require power from the 1394 bus.

VGA

The VGA connector on the NI 1450 provides connection between the NI 1450 and a VGA monitor. Use any standard 15-pin VGA cable to access the VGA connector. Figure 3-6 shows the VGA connector location and pinout. Table 3-3 lists and describes the VGA connector signals.

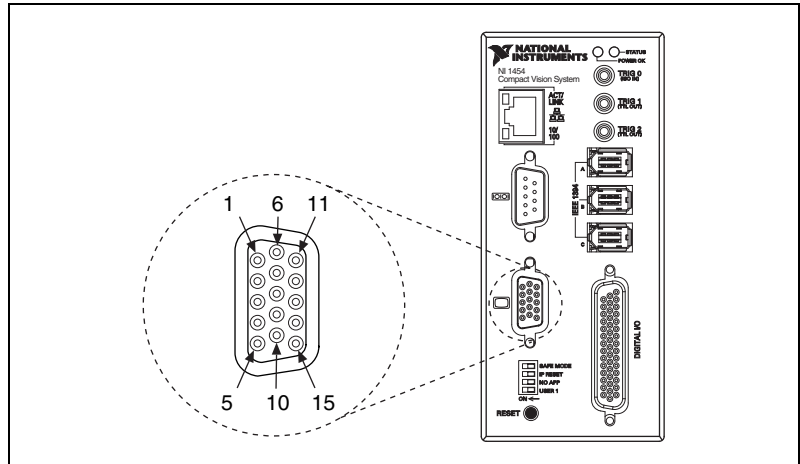

Figure 3-6. VGA Connector

Table 3-3. VGA Connector Signals

Pin	Signal Name	Signal Description
1	R	Red
2	G	Green
3	B	Blue
4	NC	No Connect
5	C	Common of the NI 1450 main power
6	C	Common of the NI 1450 main power
7	C	Common of the NI 1450 main power
8	C	Common of the NI 1450 main power
9	+5V	+5V
10	C	Common of the NI 1450 main power
11	NC	No Connect
12	SD	Serial Data
13	HSync	Horizontal Sync
14	VSync	Vertical Sync
15	SC	Serial Clock

COM1

COM1 is a high-speed RS-232 (DTE) serial port used for connecting to serial devices, such as PLCs, scanners, and lighting devices.



Note The Serial Port VIs access COM1 as Port 0.

Figure 3-7 shows the locations of the COM1 DSUB 9-pin connector. Refer to Table 3-4 for COM1 signal names and descriptions

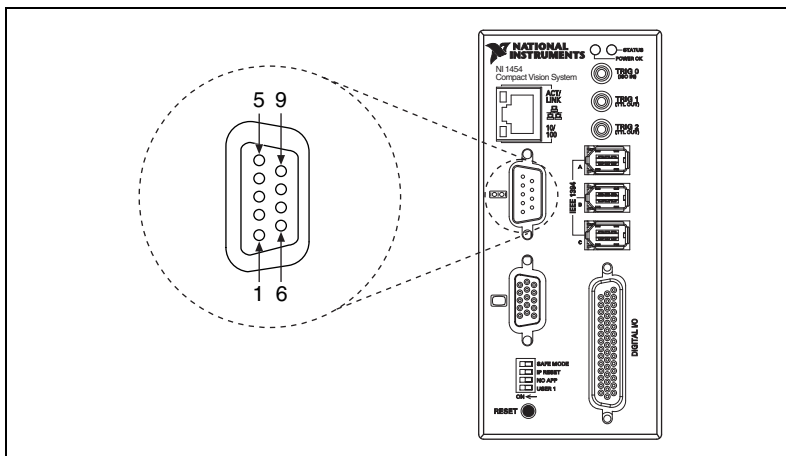

Figure 3-7. COM1 DSUB 9-Pin Connector

Table 3-4. COM1 Connector Signals

Pin	Signal Name	Signal Description
1	DCD	Data Carrier Detect
2	RXD	Receive Data
3	TXD	Transmit Data
4	DTR	Data Terminal Ready
5	C	Common of the NI 1450 main power
6	DSR	Data Set Ready
7	RTS	Ready to Send
8	CTS	Clear to Send
9	RI	Ring Indicator

Ethernet

The Ethernet port on the NI 1450 provides connection between the NI 1450 and the development computer, either directly or through a network port. The NI 1450 automatically detects the speed of the connection and configures itself accordingly.

If you are connecting the NI 1450 to the development computer through a network port, use a standard Ethernet cable. To connect the NI 1450 directly to the development computer, use an Ethernet crossover cable.

TRIG 0

The TRIG 0 isolated input on the NI 1450 provides connection to external devices, such as proximity sensors and start/stop buttons. For easy connection to the TRIG 0 input, use the National Instruments SMB 111 coaxial cable (part number 763422-01).



Note Additional isolated inputs are available on the 44-pin DSUB connector.



Caution These isolated inputs are compatible with 5 V logic if the external circuit meets the voltage and current requirements listed in Appendix B, *Specifications*.

TRIG 1 and TRIG 2

You can use the two TTL outputs available on the SMB connectors for triggering cameras and external interfaces, such as lighting control units. For easy connection to the TTL outputs, use the National Instruments SMB 111 coaxial cable (part number 763422-01).



Note Additional TTL outputs are available on the 44-pin DSUB connector.



Caution Do *not* connect voltage or current sources to TTL outputs. Doing so could damage the NI 1450.

General-Purpose Digital I/O

The 44-pin DSUB connector, shown in Figure 3-8, provides access to the general-purpose digital inputs and outputs. The general-purpose digital I/O available on this connector includes two TTL inputs, eight TTL outputs, twelve isolated inputs, and four isolated outputs. For easy connection to the digital I/O connector, use the National Instruments digital I/O cable and terminal block.

For detailed information about digital I/O functionality and recommended use cases, refer to Chapter 4, *Digital I/O Functionality*.



Note Isolated inputs are compatible with 5 V logic if the external circuit meets the voltage and current requirements listed in Appendix B, *Specifications*.

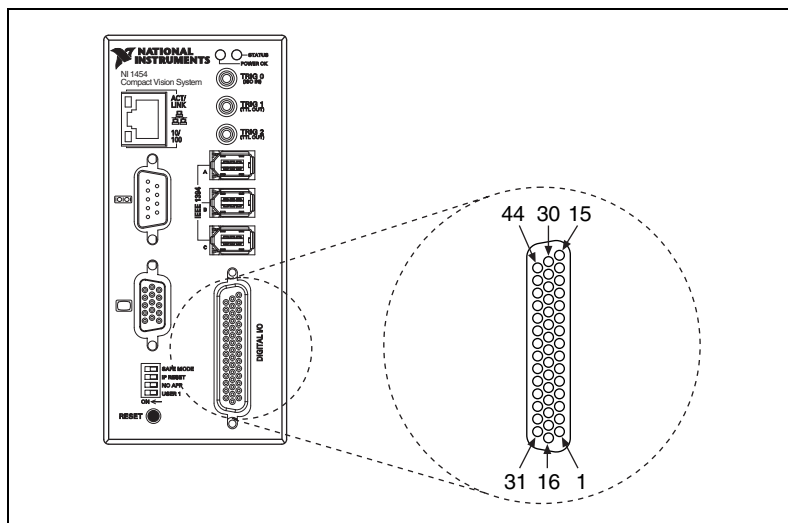

Figure 3-8. 44-Pin DSUB Connector

Table lists pin numbers, signal names, and signal descriptions for the 44-pin connector on the NI 1450 and the 37-pin terminal block.



Caution Do not draw more than 500 mA combined from the Viso pins on the 44-pin DSUB connector. Do not draw more than 100 mA from each isolated output.

Table 3-5. 44-Pin DSUB and 37-Pin Terminal Block Connector Signals

44-Pin DSUB on NI 1450 Pin Number	37-Pin Terminal Block Pin Number	Signal Name	Primary Function	Alternate Function
1	1	TTL Input 0	Pulse generator trigger input	General-purpose input
2	3	C	Common of the NI 1450 main power	—
3	4	TTL Output 0	Watchdog output	General-purpose output

Table 3-5. 44-Pin DSUB and 37-Pin Terminal Block Connector Signals (Continued)

44-Pin DSUB on NI 1450 Pin Number	37-Pin Terminal Block Pin Number	Signal Name	Primary Function	Alternate Function
4	5	TTL Output 1	Pulse generator output	General-purpose output
5	6	C	Common of the NI 1450 main power	—
6	7	TTL Output 2	Pulse generator output	General-purpose output
7	8	TTL Output 3	Pulse generator output	General-purpose output
8	6	C	Common of the NI 1450 main power	—
9	NC	NC	No connect	—
10	17	Viso	Isolated power	—
11	18	Ciso	Isolated common	—
12	19	ISO Output 0	General-purpose output	—
13	35	ISO Output 1	General-purpose output	—
14	34	Ciso	Isolated common	—
15	9	ISO Input 0	Input port, Data(0)	—
16	2	TTL Input 1	Pulse generator trigger input	General-purpose input
17	3	C	Common of the NI 1450 main power	—
18	20	TTL Output 4	Pulse generator output	General-purpose output
19	21	TTL Output 5	General-purpose output	—
20	22	C	Common of the NI 1450 main power	—
21	23	TTL Output 6	General-purpose output	—
22	24	TTL Output 7	General-purpose output	—
23	22	C	Common of the NI 1450 main power	—
24	NC	NC	No connect	—
25	33	Viso	Isolated power	—

Table 3-5. 44-Pin DSUB and 37-Pin Terminal Block Connector Signals (Continued)

44-Pin DSUB on NI 1450 Pin Number	37-Pin Terminal Block Pin Number	Signal Name	Primary Function	Alternate Function
26	34	Ciso	Isolated common	—
27	36	ISO Output 2	General-purpose output	—
28	37	ISO Output 3	General-purpose output	—
29	12	Ciso	Isolated common	—
30	10	ISO Input 1	Input port, Data(1)	—
31	11	ISO Input 2	Input port, Data(2)	—
32	13	ISO Input 3	Input port, Data(3)	—
33	16	Ciso	Isolated common	—
34	14	ISO Input 4	Input Port, Data(4)	—
35	15	ISO Input 5	Input port latch, Data(5)	—
36	28	Ciso	Isolated common	—
37	25	ISO Input 6	Quadrature encoder Phase A	General-purpose input
38	26	ISO Input 7	Quadrature encoder Phase B	General-purpose input
39	28	Ciso	Isolated common	—
40	27	ISO Input 8	Pulse generator trigger input	General-purpose input
41	29	ISO Input 9	General-purpose input	General-purpose input
42	32	Ciso	Isolated common	—
43	30	ISO Input 10	General-purpose input	General-purpose input
44	31	ISO Input 11	User shutdown	General-purpose input

Digital I/O Functionality

This chapter describes the primary functions of the digital inputs and outputs on the NI 1450 Series Compact Vision System. This chapter also includes guidelines for connecting the digital I/O and for setting up a typical NI 1450 system.

Overview

The digital I/O functions are accessible through 2 TTL inputs, 10 TTL outputs, 13 isolated inputs, and 4 isolated outputs.

Input signals can be used as triggers, product selection ports, to read quadrature encoders, or they can be user-defined. Uses for output signals include controlling camera reset and exposure, controlling strobe lighting, outputting inspection results, communicating with PLCs, or they can be user defined.

For information about how to use LabVIEW RT to implement specific digital I/O functions, refer to the application software documentation and examples in the following locations:

- Program Files\National Instruments\NI 1450 Series\Docs
- Program Files\National Instruments\LabVIEW 7.0\examples\NI 1450

The *NI 1450 Series Compact Vision System Digital I/O Help* is available for each example. This help file contains digital I/O reference information and instructions for using the LabVIEW FPGA VIs.



Tip To quickly launch the digital I/O help from an example, press <F1>.

TTL Inputs and Outputs

TTL is a fast-switching 5 V digital signaling standard commonly used for applications that require high precision, such as camera triggering. TTL inputs and outputs do not require a separate power supply.



Caution Do *not* connect voltage or current sources to TTL outputs. Doing so could damage the NI 1450.

Table 4-1 summarizes the TTL inputs and outputs available on the NI 1450.

Table 4-1. TTL Inputs and Outputs

Primary Function	Input or Output	Number Available	Signal Names	44-Pin DSUB on NI 1450 Pin Number	37-Pin Terminal Block Pin Number
Trigger	Input	2	TTL Input 0 TTL Input 1	1 16	1 2
Timed Pulse	Output	6	TRIG 1, Pulse 5 TRIG 2, Pulse 6 TTL Output 1, Pulse 1 TTL Output 2, Pulse 2 TTL Output 3, Pulse 3 TTL Output 4, Pulse 4	— — 4 6 7 18	— — 5 7 8 20
Watchdog	Output	1	TTL Output 0	3	4
General-Purpose	Output	3	TTL Output 5 TTL Output 6 TTL Output 7	19 21 22	21 23 24

Isolated Inputs and Outputs

The isolated inputs and outputs on the NI 1450 have a separate ground reference from the main NI 1450 supply, providing an easy means to prevent ground loops that can introduce noise into a system. You can apply signals up to 30 V to the isolated inputs. The voltage swing of the isolated outputs is determined by the Viso you supply on the connector.

Table 4-2 summarizes the isolated inputs and outputs available on the NI 1450.

Table 4-2. Isolated Inputs and Outputs

Primary Function	Input or Output	Number Available	Signal Names	44-Pin DSUB on NI 1450 Pin Number	37-Pin Terminal Block Pin Number
Trigger	Input	3	TRIG 0	—	—
			ISO Input 5 [†]	35	15
			ISO Input 8	40	27
Quadrature Encoder	Input	1	ISO Input 6	37	25
			ISO Input 7	38	26
External Shutdown Control	Input	1	ISO Input 11	44	31
Product Selection Port [†]	Input	1	ISO Input 0	15	9
			ISO Input 1	30	10
			ISO Input 2	31	11
			ISO Input 3	32	13
			ISO Input 4	34	14
General-Purpose	Input	2	ISO Input 9	41	29
			ISO Input 10	43	30
General-Purpose	Output	4	ISO Output 0	12	19
			ISO Output 1	13	35
			ISO Output 2	27	36
			ISO Output 3	28	37

[†] ISO Input 5 can also function as a latch for the product selection port.

Trigger Inputs

Trigger inputs are available from both TTL inputs and isolated inputs. You can use these trigger inputs to synchronize the NI 1450 with an external event, such as the assertion of a signal generated by a proximity sensor or a PLC to indicate that an inspection item is passing in front of the camera. The NI 1450 uses this input to initiate a timed pulse that can be used for camera control, lighting control, encoder pulse counting, and result output timing.

For more information about creating a timed pulse output, refer to the [Timed Pulse Output](#) section.

Alternatively, the ISO Input 5 signal can function as a latch input for the product selection port, and all five trigger inputs can function as general-purpose inputs.

Timed Pulse Output

The NI 1450 is capable of timed pulse output on six different digital outputs, which provides precise control over time-critical signals, such as camera exposure. This section describes the various uses for the timed pulse output and the parameters you can set to control these outputs.

Uses for timed pulse output include controlling camera reset and exposure, controlling strobe lighting, operating plungers on an assembly line, and communicating with PLCs. You can configure the start of the pulse output generation to occur from software or from a rising or falling edge of a trigger input.

In addition to controlling the timing of pulse output, you can also configure the polarity of the output signal, resulting in a high-true or low-true signal. Based on the polarity setting, the output signal asserts after the appropriate delay time and de-asserts after the configured pulse width. You can set the delay time in microseconds or in quadrature encoder counts from the start signal—either a hardware trigger or a software command. Width is always configured in microseconds.

Initiating a Timed Pulse

Each timed pulse generator has a trigger input that specifies whether to wait on a particular trigger input to generate the pulse or to immediately generate the pulse when software sets the mode to Start.

When the pulse generator is configured for a particular trigger input, after generating a pulse, it waits for another trigger before generating another pulse. When the pulse generator is configured to immediately generate the pulse on a software start, after generating a pulse, it immediately generates another pulse.

If the trigger input is set to immediate, the pulse generation occurs as soon as the pulse mode is set to start. If the trigger input is set to one of the hardware trigger inputs, the timed pulse output waits for an assertion edge on the appropriate trigger input. The assertion edge is configurable based on the trigger polarity parameter. It then generates one pulse and rearms to wait for the next trigger. In either case, the pulse output generation stops and resets if the pulse mode parameter is set to stop.

Figure 4-1 shows an output pulse when a trigger is selected.

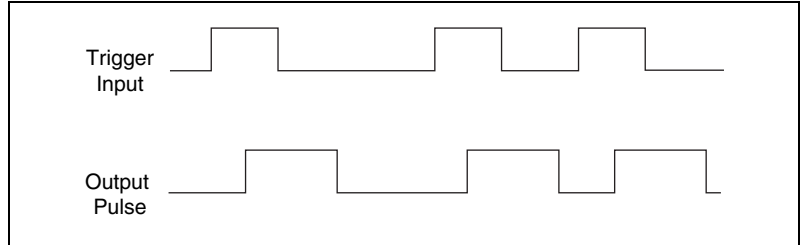

Figure 4-1. Output Pulse When Trigger Is Selected

Pulse Modes

Each pulse generator has a Start and a Stop mode. Configure the pulse generator when in Stop mode and then set it to Start mode.

Pulse Delay

Pulse delay is the amount of time between a trigger and the first (assertion) edge of an output pulse. The pulse delay is configurable in units of microseconds or quadrature encoder counts. If configured for microseconds, available values are between 10 μs and 4,294,967,295 μs , which is 4,294 seconds, or approximately 71 minutes. If the delay is configured for quadrature encoder counts, the range of choices is 0 counts to 4,294,967,295 counts.

Pulse Width

Pulse width is the amount of time between the first (assertion) edge of a pulse and the second (deassertion) edge. Pulse width is configurable only in microseconds from 10 μs to 4,294,967,295 μs .

Trigger Polarity

Each pulse generator can be individually configured for rising or falling edge triggering. Even if multiple pulse generators are using the same triggering, each can have different polarities.

Figure 4-2 shows the output of a pulse generator configured to look for a rising edge trigger and output a high pulse with a microsecond width and delay.

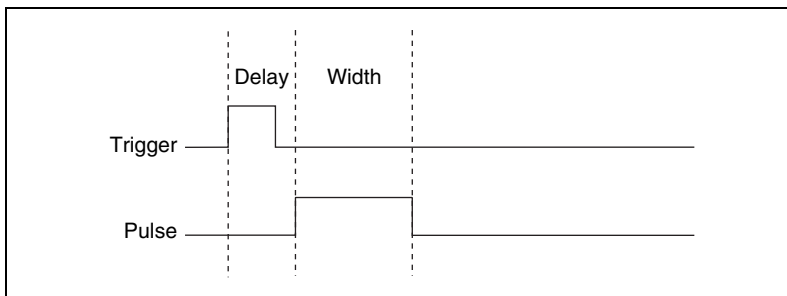

Figure 4-2. High Pulse with Rising Edge Trigger

Figure 4-3 shows how to create a high and low pulse train with a microsecond delay and width.

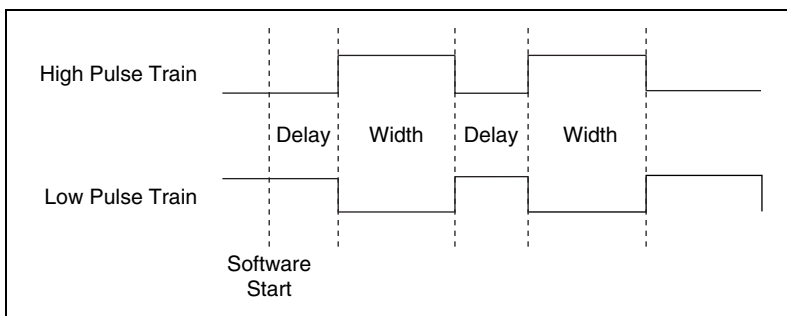

Figure 4-3. High and Low Pulse Trains

Quadrature Encoder

The quadrature encoder uses ISO Input 6 for its Phase A input and ISO Input 7 for its Phase B input. Encoder speed is limited by the speed of the isolated inputs. Each isolated input can change at a maximum rate of 100 kHz, making the maximum encoder rate 400,000 counts/s.

The quadrature encoder can also be used as a timebase for the pulse generation delay.

Figure 4-4 shows a rising edge trigger and a low pulse with a quadrature encoder delay and a microsecond width.

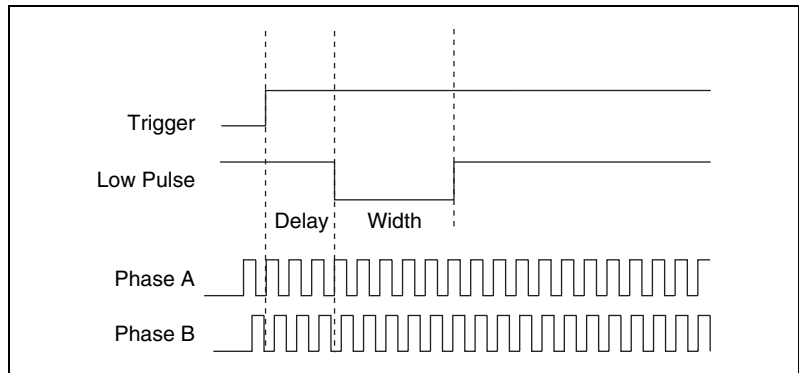

Figure 4-4. Rising Edge Trigger, Low Pulse with a Quadrature Encoder Delay

Product Selection Port

The product selection port consists of a group of five isolated digital inputs that the software running on the NI 1450 reads simultaneously. You can program the NI 1450 to switch between up to 32 (2^5) inspection sequences for different parts on an assembly line.

Based on the input to the product selection port, you can configure the application software to run the appropriate inspection sequence. For example, an upstream NI 1450 programmed for part classification might drive the product selection port of a downstream NI 1450. Alternatively, a PLC with information about which part is being inspected can drive the product selection port of the NI 1450.

Using ISO Input 5 as a Latch

You can configure the product selection port to use ISO Input 5 as a latch. A rising edge on ISO Input 5 can latch the data into a data register on the NI 1450. Before each inspection, the software checks the status of the product select inputs and reads the most recent value latched into the register.



Note In Vision Builder AI, ISO Input 5 is always designated as a latch.

Table 4-3 lists the product selection ports.

Table 4-3. Product Selection Port

Function	External Connection
Data(5), rising edge latch	ISO Input 5
Data(4)	ISO Input 4
Data(3)	ISO Input 3
Data(2)	ISO Input 2
Data(1)	ISO Input 1
Data(0)	ISO Input 0

General-Purpose I/O

General-Purpose Inputs

General-purpose inputs are available as both TTL and isolated inputs. At any time, the software running on the NI 1450 can read these inputs.

The primary difference between general-purpose inputs and trigger inputs is that you cannot use general-purpose inputs to initiate a timed pulse generator. In an application, use the general-purpose inputs to get the status of the inputs at a given point and not to synchronize the NI 1450 system with an external event.

An example of how to use general-purpose inputs is reading the status of a general-purpose input as the first step in your inspection sequence and recording that value as part of your inspection.

General-Purpose Outputs

General-purpose outputs are also available as both TTL and isolated outputs. At any time, the software running on the NI 1450 can drive these outputs high or low.

The primary difference between general-purpose outputs and timed pulse outputs is that the timing of general-purpose outputs is controlled by software rather than hardware. As a result, timing of general-purpose outputs changes as the inspection algorithm changes, which makes general-purpose outputs less appropriate than timed outputs for camera control, strobe light control, and other applications that require precise timing.

An example of using general-purpose outputs is driving a relay that turns on an Inspection in Progress light for an operator to see while the inspection sequence is running.

Fault Conditions

The NI 1450 recognizes the following fault conditions:

- External shutdown, when Shutdown mode is enabled
- Watchdog expiration, when configured for system shutdown
- Overheat

The behavior of the NI 1450 in the event of a fault condition is dependent on configuration settings of the **SAFE MODE** DIP switch and the software-enabled Shutdown mode.

To resume operation, address the fault condition and reset the NI 1450.

The following sections describe each fault condition, and Table 4-4 summarizes how user configuration affects the behavior of the NI 1450 in the event of a fault condition.

Shutdown

Shutdown mode is a software-enabled feature that when activated allows an external device to halt the NI 1450 processing operations. Additionally, enabling Shutdown mode allows you to specify user-defined shutdown states for all fault conditions.

When Shutdown mode is enabled and the shutdown input signal, ISO Input 11, turns off, the NI 1450 registers an external shutdown condition. When this fault occurs, the **POWER OK** LED turns red and all system operation halts. To resume operation, you must reset the NI 1450.

For all fault conditions, outputs operate according to user-defined shutdown states. Each TTL output is configurable to drive high, drive low, or 3-state, and each isolated output is on/off configurable.

Because the NI 1450 cannot run VIs in Safe mode, Shutdown mode is unavailable when the **SAFE MODE** DIP switch is turned on.

Refer to Table 4-4 for a summary of how user configuration affects the shutdown condition.

Disabling Shutdown Mode

To disable Shutdown mode once it is enabled, remove Shutdown mode from the software script and reset the NI 1450. To reset the system, press the **RESET** button on the NI 1450 front panel for at least two seconds.



Note For prototyping when equipment is unavailable, you can wire from Viso to ISO Input 11 to simulate external equipment that indicates to the NI 1450 to operate normally.

Watchdog

The watchdog timer is a software configurable feature that can monitor software on the NI 1450 and take action if the software is unresponsive. The millisecond counter on the watchdog timer is configurable up to 65,534 ms, in 1 ms increments, before it expires.

Configure the watchdog to take one of the following actions when it expires:

- **Indicator Only**—This option sends the expiration signal back to the development machine through software. **True** indicates an expired watchdog timer, and **False** indicates an unexpired watchdog timer. The expiration signal that indicates an expired watchdog continues to assert until the watchdog is disarmed. Disarming the watchdog resets the I/O.



Caution Use the Indicator Only option *only* to test the watchdog. If software becomes unresponsive, it cannot be relied upon to send notification to the host.

- **TTL Output 0**—This option outputs a signal on TTL Output 0. A **High** on TTL Output 0 indicates that the watchdog has expired, and a **Low** indicates that it has not expired. If the watchdog timer has expired, the expiration signal will continue to assert until the watchdog is disarmed.



Note LabVIEW RT supports all watchdog timer options. Vision Builder AI supports only the Indicator Only and TTL Output 0 options.

- **System Shutdown**—This option halts the NI 1450 operation and turns the **POWER OK** LED red. If Shutdown mode is enabled, the outputs go to the user-defined shutdown states.

Table 4-4 summarizes how user configuration affects the shutdown condition.

Overheat

Operating the NI 1450 outside of its temperature specifications may cause the NI 1450 to overheat. Refer to Appendix B, *Specifications*, for temperature specifications.

In the event of an overheat, all NI 1450 operation halts and the **POWER OK** LED turns red. If Shutdown mode is enabled, the outputs go to the user-defined shutdown states.

Table 4-4. Configuration Settings and Effects

Fault Condition	Configuration Settings		Configuration Effects	
	Safe Mode DIP	Shutdown Enabled	Processing Halts	Outputs Change to User-Defined States
External Shutdown	On	N/A	N/A	No
	Off	On	Yes	Yes
	Off	Off	No	No
Watchdog	On	N/A	N/A	No
	Off	On	Yes	Yes
	Off	Off	Yes	No
Overheat	On	N/A	Yes	No
	Off	On	Yes	Yes
	Off	Off	Yes	No

Considerations When Connecting the Digital I/O

The isolated trigger inputs on the NI 1450 are current sinking and optically isolated. Figure 4-6 shows the trigger input interface circuit.

Wiring an Isolated Input to a Sourcing Output Device

You can wire an isolated input to a sourcing output device, as shown in the example in Figure 4-5. Refer to Appendix B, *Specifications* for switching thresholds and current requirements.



Caution Do *not* apply a voltage greater than 30 VDC to the isolated inputs. Doing so could damage NI 1450.

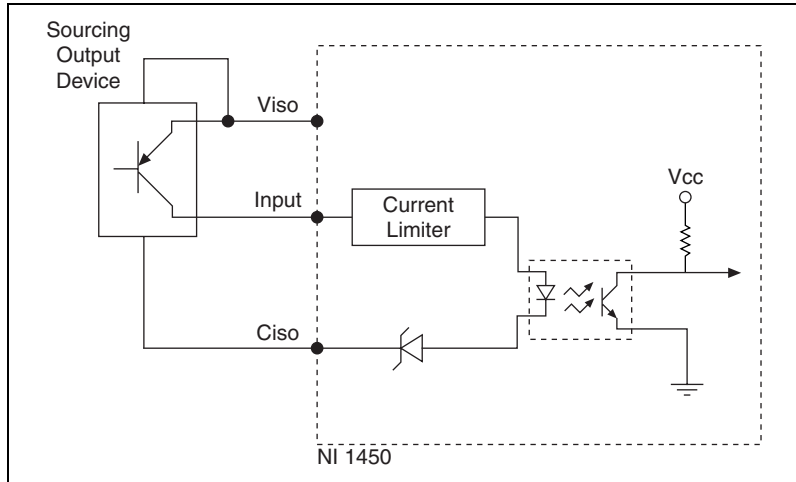

Figure 4-5. Example of Connecting an Isolated Input to a Sourcing Output Device

Wiring an Isolated Output to an External Load

The digital output circuit sources current to external loads, as shown in the example in Figure 4-6. The maximum output current of this circuit is 100 mA.

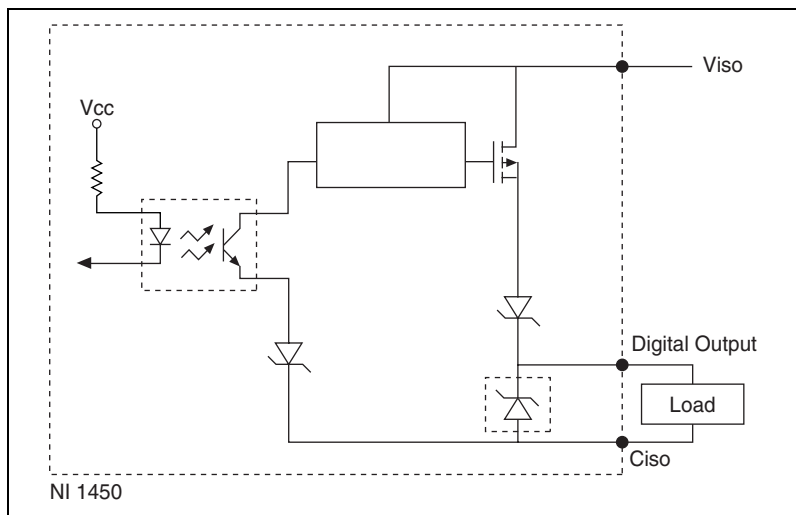

Figure 4-6. Example of Connecting an Isolated Output to an External Load

Protecting Inductive Loads

When an inductive load, such as a relay or solenoid, is connected to an output, a large counter-electromotive force may occur at switching time due to energy stored in the inductive load. This flyback voltage can damage the outputs and the power supply.

To limit flyback voltages at the inductive load, install a flyback diode across the load. Mount the flyback diode as close to the load as possible. Use this protection method if you connect any of the isolated outputs on the NI 1450 to an inductive load.

Figure 4-7 shows an example of using an external flyback diode to protect inductive loads.

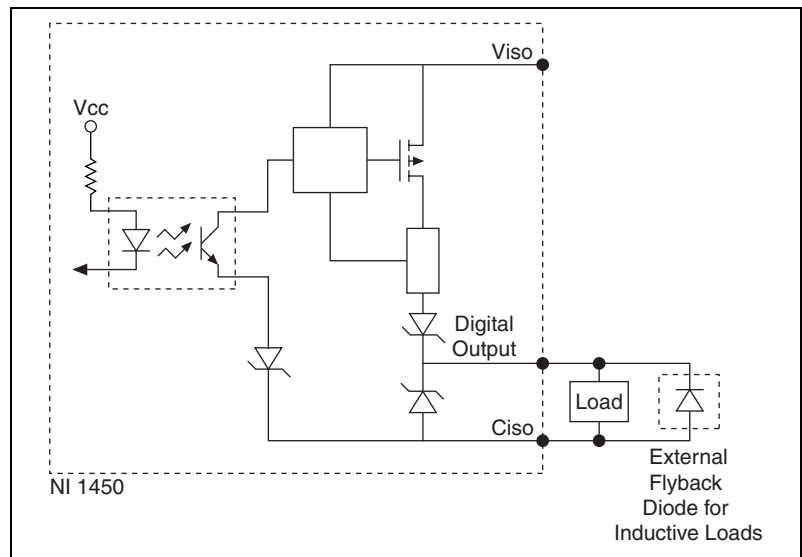

Figure 4-7. Example of Using an External Flyback Diode for Inductive Loads

Transmission Line Effects

Transmission line effects can degrade the signals on the I/O cables and cause instability. To minimize transmission line effects, use twisted-pair wires with a characteristic impedance of 118 Ω to connect external signals to the 44-pin I/O DSUB connector. Use a 75 Ω coaxial cable, such as RG-179, to connect to the SMB connectors.

Figure 4-8 shows connections to the 44-pin DSUB connector and the TRIG 0 SMB connector that minimize transmission line effects.

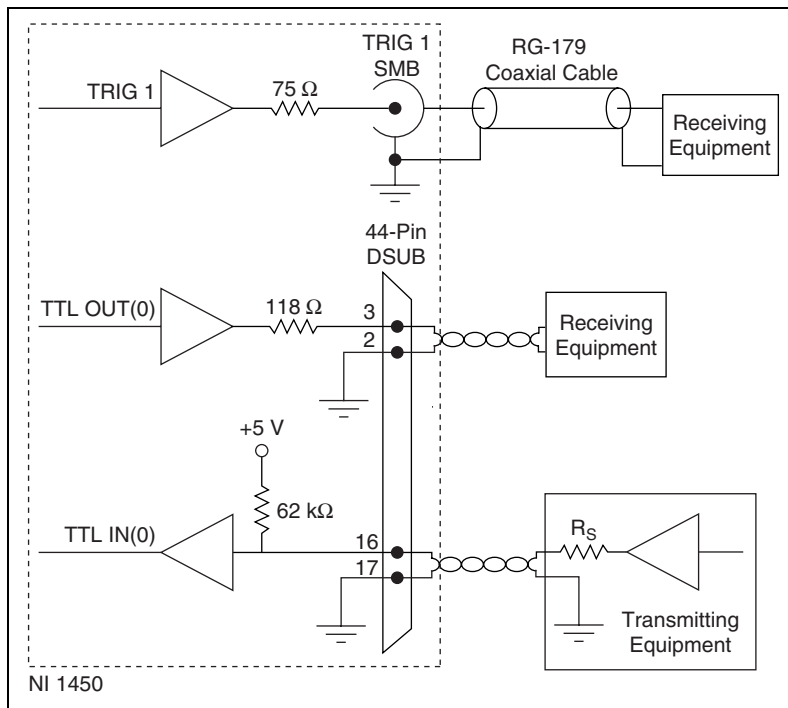

Figure 4-8. Example Connections

When connecting to TTL inputs on the NI 1450 device, match the output impedance of the transmitting device to the characteristic impedance of the cable. For example, if the cable characteristic impedance is $118\ \Omega$, make R_s equal to $118\ \Omega$, as shown in Figure 4-8.

Typical System Setup

Digital I/O configuration varies depending on the number of cameras your system setup requires. You can access the digital I/O through the 44-pin DSUB connector or through the 3 SMB connectors.

The digital I/O capabilities of the SMB connectors on the NI 1450 are ideal for typical single-camera applications. The SMB connectors are labeled **TRIG 0**, **TRIG 1**, and **TRIG 2**.

Table 4-5 summarizes a typical single-camera configuration.

Table 4-5. Typical Single-Camera System Setup

Signal Name	Signal Type	Purpose
TRIG 0	Isolated input	Trigger input from proximity sensor or external device
TRIG 1	Timed pulse TTL output	Exposure start and control signal to camera
TRIG 2	Timed pulse TTL output	Strobe light control

Figure 4-9 shows a typical single-camera setup.

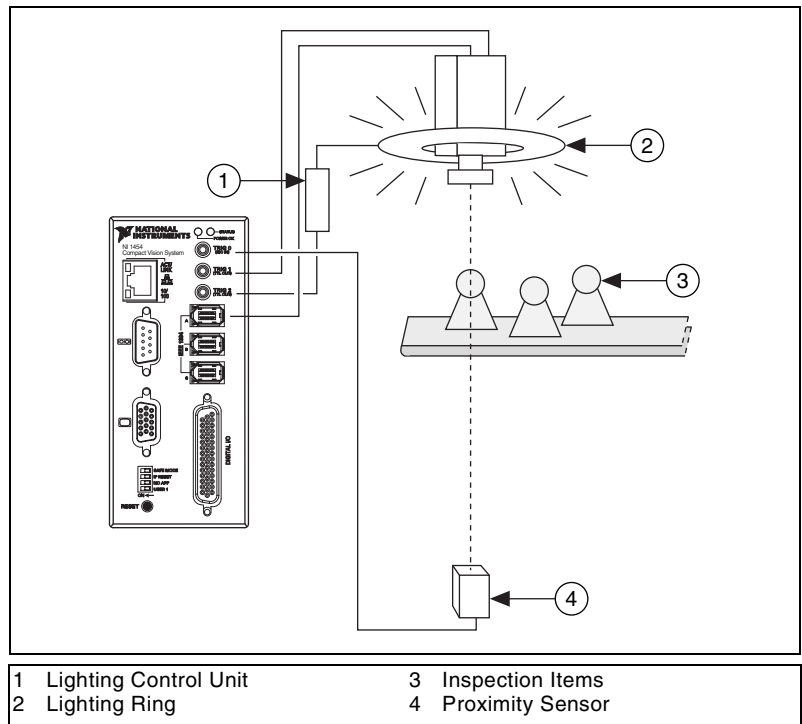

Figure 4-9. Typical Single-Camera Setup

Deployment

This chapter provides guidelines for connecting the NI 1450 Series Compact Vision System to a network.

Connecting Multiple NI 1450s

An Ethernet connection between the development computer and the NI 1450 allows you to assign an IP address, configure the NI 1450, download inspection tasks, and remotely monitor an ongoing inspection.

As with all Ethernet devices, you can connect multiple NI 1450s to the same network, as shown in Figure 5-1.

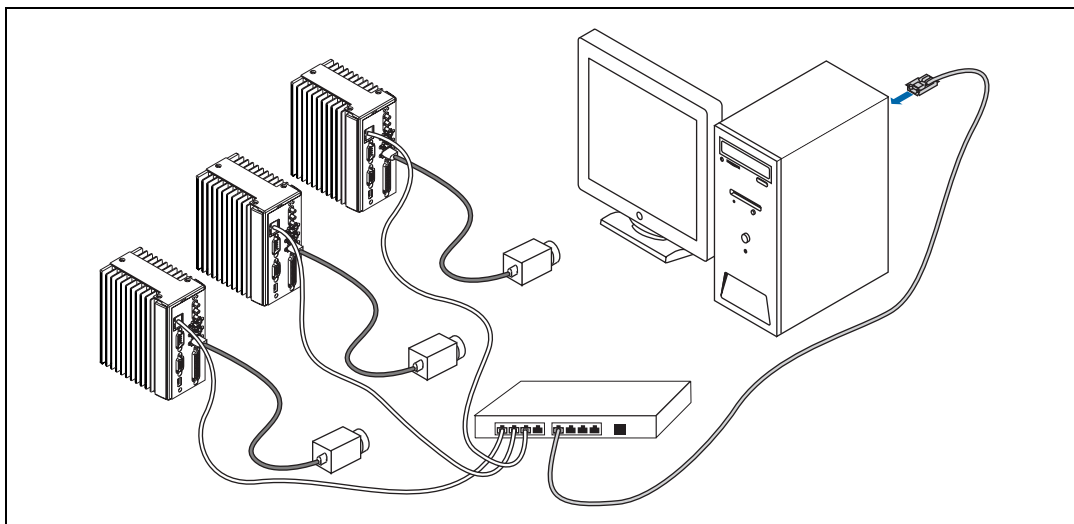

Figure 5-1. Multiple NI 1450s Connected to the Same Network

To connect multiple NI 1450s to the same network, each NI 1450 must have a unique IP address. By default, the configuration utility running on the development computer displays each NI 1450 that exists on the subnet. To add entries for NI 1450s that exist on other subnets, you must know the IP address assigned to each NI 1450. This feature allows remote configuration, programming, and monitoring of any NI 1450 not protected by a firewall or user password.

Use the NI 1450 serial number and media access control (MAC) address to uniquely identify each unit. The serial number and MAC address are printed on the top side of each NI 1450 unit, as shown in Figure 5-2.

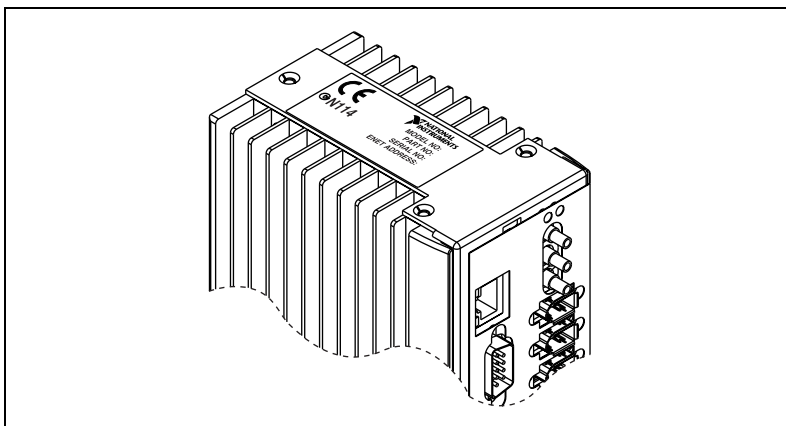

Figure 5-2. Serial Number and MAC Address Label on the NI 1450

The configuration environment on the host machine displays these values in order to distinguish one NI 1450 from another. In addition to distinguishing units based on serial number and MAC address, you can also assign each NI 1450 a descriptive name in the configuration environment.

When configured to run an inspection, the NI 1450 can run autonomously without connection to the host machine. All image acquisition, inspection, decision making, and I/O occurs on the NI 1450 itself. For local monitoring of the inspection, you can connect a monitor directly to the **Video Out** connector on the NI 1450, as shown in Figure 5-3.

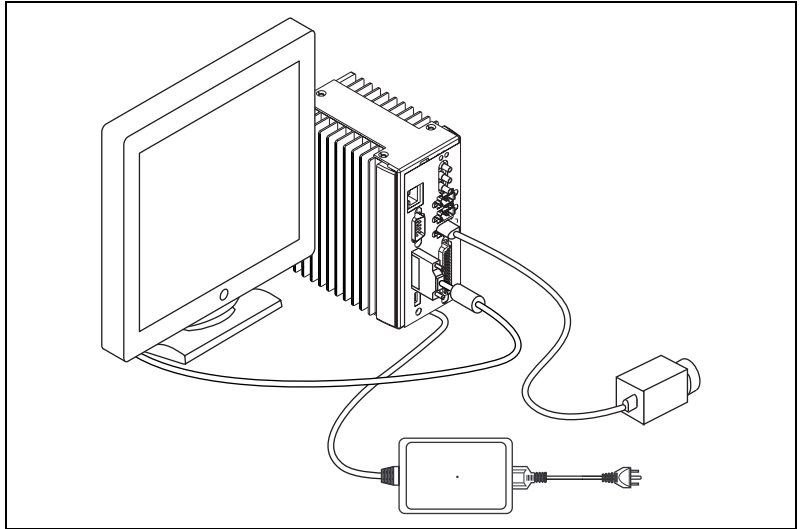

Figure 5-3. NI 1450 Series Compact Vision System Connected to a Monitor

At any time, you can reconnect the host machine to the NI 1450 and remotely monitor progress.

Troubleshooting

This appendix provides instructions for troubleshooting the NI 1450.

Software Configuration Problems

NI 1450 Does Not Appear in MAX or in Vision Builder AI

Possible causes and solutions:

- Verify that there is power to the NI 1450 and that both the NI 1450 and the development computer are properly connected to the network. The **POWER OK** LED should be lit. When you click **Browse**, the **ACT/LINK** LED on the NI 1450 should flash to indicate that communications are taking place.
- Certain network devices, such as switches and routers, may filter out the directed UDP broadcast packets the development computer uses to communicate with unconfigured NI 1450s, even if these devices are on the same subnet. You can test this by connecting the development computer and the NI 1450 directly to a network port or by using a crossover cable between the NI 1450 and the development computer. If the NI 1450 appears in the software using this configuration, but not when connected to the larger network, the network is not properly communicating with the NI 1450. Consult your network administrator.
- The NI 1450 may have been configured on another network and then moved to the current network. Reconfigure the NI 1450 on the current network.
- The grade of cable you are using may be insufficient for the speed of your network, or you may be using the wrong type of Ethernet cable. Use a straight-through cable when connecting to network hardware. Use a crossover cable to connect directly to the development computer.

- Another device on the network is using the IP address assigned to the NI 1450. Either remove or reconfigure the other device, or reconfigure the NI 1450 IP address.
- The DIP switch settings on the NI 1450 may be invalid, such as all switches set to the **ON** position. Change the DIP switch settings and reset the NI 1450 by pressing the **RESET** button on the NI 1450 for at least two seconds.

Error When Configuring IP Settings for the NI 1450

The NI 1450 cannot be configured if the subnet mask or IP address is incompatible with the network settings. Verify that the values entered for all network parameters are valid.

Status of NI 1450 in MAX and Vision Builder AI is No Software Installed

Install application and driver software on the NI 1450. Refer to Chapter 2, [Setup and Configuration](#), for installation instructions.

No Camera Found

Verify that the total power requirements of the cameras do not exceed the power the NI 1450 provides on the 1394 bus. Verify that the cameras comply with the *IIDC Digital 1394-based Camera Specification, Version 1.30*.

Hardware Errors

POWER OK LED is Red

The NI 1450 is in one of the following fault conditions:

- Shutdown enabled in software, but ISO Input 11 is not turned on
 - ISO Input 11 is used to indicate to the NI 1450 that all external devices are ready for operation. When ISO Input 11 turns off, the NI1450 shuts down. Either turn on ISO Input 11 with an external source and reset the NI 1450, or disable Shutdown in the software.



Note For prototyping when external equipment is unavailable, Viso can be wired to ISO Input 11 to turn it on.

- Watchdog expired while configured for the system shutdown option
 - Determine if the interval between watchdog resets is insufficient for the processing time. Check the software to determine if it could monopolize the processor.
- Processor overheat
 - Make sure you are operating the NI 1450 in compliance with the temperature specifications in Appendix B.

Refer to Table 4-4, *Rising Edge Trigger, Low Pulse with a Quadrature Encoder Delay*, for more information about fault conditions.

Cannot Drive Isolated Outputs

Verify that you have power connected to Viso and Ciso inputs on the NI 1450 power connector and that the contact at the screw terminals is solid. Because these outputs are electrically isolated from the NI 1450 main supply, they require power in addition to the NI 1450 main supply.

Runaway Startup Application

If a runaway startup application causes the NI 1450 to become unresponsive, power off the NI 1450 and then reboot it with either the **NO APP** switch or the **SAFE MODE** switch in the **ON** position. Rebooting the NI 1450 with the **NO APP** switch enabled prevents any VIs from running at startup. Rebooting with the **SAFE MODE** switch enabled starts the NI 1450 in Safe mode and does not launch the embedded LabVIEW RT engine. Refer to the *DIP Switches* section of Chapter 3, *LEDs, DIP Switches, and Connectors*, for more information about these DIP switches.

System Displays a Missing Operating System Error at Startup

The NI 1450 was powered on or reset with all DIP switches in the **ON** position. Set the DIP switches to the off position, and reset the NI 1450 by pressing the **RESET** button for at least two seconds.

LED Error Indications

The NI 1450 indicates specific error conditions by flashing the orange **STATUS** LED a specific number of times. Table A-1 describes the **STATUS** LED flashing sequences and the corresponding error condition.

Table A-1. STATUS LED Flashes and Corresponding Error Conditions

Number of Flashes	Error Condition
0 (stays lit)	The NI 1450 has detected an internal error. Contact National Instruments for assistance.
1	The NI 1450 is unconfigured.
2	The NI 1450 has detected an error in its software. This usually occurs when an attempt to upgrade the firmware is interrupted. Repeat the firmware upgrade process.
3	The NI 1450 is in Safe mode.
4 (or more)	The NI 1450 has detected an unrecoverable error. Contact National Instruments for assistance.

POWER OK LED Is Not Lit When the NI 1450 is Powered on

If the power supply is properly connected to the NI 1450, but the **POWER OK** LED does not light up, check that the power supply is 24 VDC $\pm 10\%$ and within the specifications outlined in Appendix B, *Specifications*. Using a power supply that is not within these specifications might result in an unresponsive or unstable system and could damage the NI 1450.

Specifications

This appendix lists the specifications of the NI 1450 Series Compact Vision System. These specifications are typical at 25 °C, unless otherwise noted.

Power Requirements

Main supply voltage	24 VDC ±10%
Power (excluding cameras).....	12 W, typical 22 W, maximum
1394 bus power	18 W, maximum (shared by all three ports)
Isolated supply ¹	5 to 30 VDC

Memory

SDRAM	128 MB
Nonvolatile storage	32 MB

Network

Network interface.....	10BaseT and 100BaseTX Ethernet
Compatibility	IEEE802.3
Communication rates	10 Mbps, 100 Mbps, auto-negotiated
Maximum cabling distance	100 m/segment

¹ Do not draw more than 500 mA combined from the Viso pins on the 44-pin DSUB connector. Do not draw more than 100 mA from each isolated output.

TTL Inputs and Outputs

Digital logic levels

Level	Minimum	Maximum
Input low voltage (V_{IL})	0 V	0.5 V
Input high voltage (V_{IH})	2.2 V	5 V
Output low voltage (V_{OL}), at 5 mA	2.4 V	—
Output high voltage (V_{OH}), at 5 mA	—	0.4 V

TTL Inputs

Number of channels.....2
 Maximum pulse rate2 MHz
 Minimum pulse detected200 ns

TTL Outputs

Number of channels.....10
 Output voltage range0 V to 5 V
 Maximum pulse rate2 MHz

Optically Isolated Inputs and Outputs

Isolated (Current Sinking) Inputs

Number of channels.....13
 Input voltage range0 V to 30 V
 Input ON voltage3.5 V to 30 V
 Input OFF voltage.....0 V to 2 V
 Turn-on current.....4 mA, typical;
 7.1 mA, minimum;
 14 mA, maximum
 (current limited)

Maximum pulse rate..... 100 kHz

Minimum pulse detected..... 10 μ s

Reverse polarity protection yes

Isolated (Current Sourcing) Outputs

Number of channels 4

On-state voltage range 5 V to 30 V, maximum

Maximum on-state voltage

drop from Viso..... 1.2 V at 100 mA

Output current 100 mA, maximum

Maximum pulse rate..... 10 kHz (maximum load resistance
100 k Ω)

Minimum pulse generated..... 100 μ s

Reverse polarity protection Yes

IEEE 1394

Number of ports 3

Speed..... 100, 200, or 400 Mbps

Available bus power..... Refer to the *Power Requirements*
section

Physical Characteristics

Dimensions..... 10.2 \times 12.7 \times 6.4 cm
(4 \times 5 \times 2.5 in.)

Weight..... 977 g (2 lbs 2.4 oz)

Environmental

The NI 1450 is intended for indoor use only.

Operating temperature,
vertical mounting position0 to 55 °C

Operating temperature,
all other positions.....0 to 45 °C

Storage temperature–55 to 85 °C

Humidity10 to 90% RH, noncondensing

Pollution Degree2

Safety

The NI 1450 Series Compact Vision System meets the requirements of the following standards for safety and electrical equipment for measurement, control, and laboratory use:

- EN 61010-1, IEC 61010-1
- UL 3121-1, UL 61010C-1
- CAN/CSA C22.2 No. 1010.1



Note For UL and other safety certifications, refer to the product label or visit ni.com.

Electromagnetic Compatibility

EmissionsEN 55011 Class A at 10 m
FCC Part 15A above 1 GHz

ImmunityEN 61326:1997 + A2:2001,
Table 1

EMC/EMICE, C-Tick, and FCC Part 15
(Class A) Compliant



Note For full EMC compliance, you must operate this device with shielded cabling.

CE Compliance

This product meets the essential requirements of applicable European Directives, as amended for CE marking, as follows:

Low-Voltage Directive (safety) 73/23/EEC

Electromagnetic Compatibility
Directive (EMC) 89/336/EEC



Note Refer to the Declaration of Conformity (DoC) for this product for any additional regulatory compliance information. To obtain the DoC for this product, click **Declarations of Conformity Information** at ni.com/hardref.nsf/. This Web site lists the DoCs by product family. Select the appropriate product family, followed by your product, and a link appears to the DoC in Adobe Acrobat format. Click the Acrobat icon to download or read the DoC.



Technical Support and Professional Services

Visit the following sections of the National Instruments Web site at ni.com for technical support and professional services:

- **Support**—Online technical support resources include the following:
 - **Self-Help Resources**—For immediate answers and solutions, visit our extensive library of technical support resources available in English, Japanese, and Spanish at ni.com/support. These resources are available for most products at no cost to registered users and include software drivers and updates, a KnowledgeBase, product manuals, step-by-step troubleshooting wizards, conformity documentation, example code, tutorials and application notes, instrument drivers, discussion forums, a measurement glossary, and so on.
 - **Assisted Support Options**—Contact NI engineers and other measurement and automation professionals by visiting ni.com/ask. Our online system helps you define your question and connects you to the experts by phone, discussion forum, or email.
- **Training**—Visit ni.com/training for self-paced tutorials, videos, and interactive CDs. You also can register for instructor-led, hands-on courses at locations around the world.
- **System Integration**—If you have time constraints, limited in-house technical resources, or other project challenges, NI Alliance Program members can help. To learn more, call your local NI office or visit ni.com/alliance.
- **Declaration of Conformity (DoC)**—A DoC is our claim of compliance with the Council of the European Communities using the manufacturer's declaration of conformity. This system affords the user protection for electronic compatibility (EMC) and product safety. You can obtain the DoC for your product by visiting ni.com/hardref.nsf.

- **Calibration Certificate**—If your product supports calibration, you can obtain the calibration certificate for your product at ni.com/calibration.

If you searched ni.com and could not find the answers you need, contact your local office or NI corporate headquarters. Phone numbers for our worldwide offices are listed at the front of this manual. You also can visit the Worldwide Offices section of ni.com/niglobal to access the branch office Web sites, which provide up-to-date contact information, support phone numbers, email addresses, and current events.

Glossary

Symbol	Prefix	Value
μ	micro	10^{-6}
m	milli	10^{-3}
k	kilo	10^3
M	mega	10^6

Symbols

$^{\circ}\text{C}$ Degrees Celsius.

A

AC Alternating current.

acquisition window The image size specific to a video standard or camera resolution.

B

b Bits.

B Bytes.

buffer Temporary storage for acquired data.

D

DAQ Data acquisition. (1) Collecting and measuring electrical signals from sensors, transducers, and test probes or fixtures and inputting them to a computer for processing; (2) Collecting and measuring the same kinds of electrical signals with A/D or DIO boards plugged into a computer, and possibly generating control signals with D/A and/or DIO boards in the same computer.

DC Direct current.

DCAM-compliant Cameras that comply with the *IIDC 1394-based Digital Camera Specification, Version 1.30*.

DIP switch Dual Inline Package switch.

DNS Domain Name System.

E

Ethernet crossover cable Category 5 or Category 6 cable used for direct connection between the development computer and the Real-Time target.

Ethernet cable, standard Category 5 or Category 6 Ethernet cable used to connect a Real-Time target to a network port.

F

FTP File Transfer Protocol.

H

Hz Hertz. Frequency in units of one cycle per second.

I

IEEE Institute of Electrical and Electronics Engineers. A standard-setting body.

interrupt A computer signal indicating that the CPU should suspend its current task to service a designated activity.

interrupt level The relative priority at which a device can interrupt.

I/O Input/Output.

IRQ Interrupt request. *See* interrupt.

L

LED Light-emitting diode.

M

m Meters.

MAC Media access control. The MAC address uniquely identifies each unit connected to a network.

N

NI-IMAQ Driver software for National Instruments image acquisition (IMAQ) hardware.

P

PG Pulse Generation.

PLC Programmable Logic Controller. An industrial computer used for factory automation, process control, and manufacturing systems.

POST Power-On Self Test.

R

ROI Region of interest. A hardware-programmable rectangular portion of the acquisition window.

RS-232 Standard electrical interface for serial data communications.

S

subnet A set of systems whose IP addresses are configured such that they can communicate directly with one another. Data will not flow through an intermediate router.

T

TCP Transmission Control Protocol. A set of standard protocols for communicating across a single network or interconnected set of networks. TCP is for high-reliability transmissions.

U

UDP User Datagram Protocol. A set of standard protocols for communicating across a single network or interconnected set of networks. UDP is for low-overhead transmissions.

V

V Volts.

VDC Volts direct current.

VI Virtual Instrument. A combination of hardware and/or software elements, typically used with a PC, that has the functionality of a classic stand-alone instrument.

W

W Watts.

Index

Numerics

100 Mbps LED, 3-2

A

accessories, 2-2

application software

installing LabVIEW, 2-15

installing Vision Builder AI, 2-13

installing Vision Development
Module, 2-15

B

bandwidth, available (table), 1-3

C

cables

crossover, 2-3

digital I/O, 2-2

Ethernet crossover, 2-2

Ethernet standard, 2-2

SMB to BNC, 2-3

characteristic impedance, 4-14

calibration certificate, C-2

camera

available bandwidth, 1-3

connecting to the NI 1450, 2-8

digital camera specification, 1-1

video formats, 1-3

COM1, connector signals, 3-10

connecting multiple systems

subnet, 5-2

connectors, 3-6

COM1, 3-10

Ethernet, 3-11

IEEE 1394, 3-8

SMB, 3-6

TRIG 0, 3-11

TRIG 1, 3-11

TRIG 2, 3-11

VGA, 3-8

contacting National Instruments, C-2

conventions used in the manual, v

customer

education, C-1

professional services, C-1

technical support, C-1

D

DCAM specification, 1-1, G-1

Declaration of Conformity, C-1

deployment, 5-1

development computer

connecting to NI 1450, 2-12

connecting to NI 1450 system, 2-11

installing application software, 2-13

installing LabVIEW, 2-15

installing Vision Development
Module, 2-15

diagnostic resources, C-1

digital camera specification, 1-1

digital I/O

44-pin DSUB, 3-11

cable, D44, 3-11

connection considerations, 4-11

connector (table), 3-6

connector pinout (diagram), 3-12

connector signals (table), 3-12

examples (LabVIEW RT), 4-1

external load, wiring, 4-12

general-purpose, 3-11

- isolated I/O, 4-2
- isolated I/O (table), 4-3
- protecting inductive loads, 4-13
- signal functionality, 4-1
- sourcing output device, wiring, 4-11
- sourcing output device, wiring (diagram), 4-12
- transmission line effects, 4-13
- TTL, 4-2
- DIP switches
 - IP RESET, 3-5
 - location, 3-4
 - NO APP, 3-5
 - overview, 3-3
 - SAFE MODE, 3-4
- documentation
 - hardware, 2-3
 - LabVIEW RT, 2-3
 - online library, C-1
 - Vision Builder AI, 2-3
 - Vision Development Module, 2-3
- drivers
 - instrument, C-1
 - software, C-1

E

- electromagnetic compatibility
 - specifications, B-4
- environmental specifications, B-4
- error indications (table), A-3
- Ethernet
 - connecting NI 1450
 - diagram, 2-12
 - connector, 3-11
 - crossover cable, 2-3
 - LINK LED, 3-2
 - port (table), 3-6
- example code, C-1
- external load, wiring, 4-12

F

- flyback diode, inductive loads (diagram), 4-13
- flyback voltage, flyback diode, 4-13
- frequently asked questions, C-1

G

- grounding lug, 3-8

H

- hardware connection
 - accessories, 2-2
 - basic components, 2-8
 - camera, monitor, 2-8
 - connecting a camera, 2-8
 - connecting the NI 1450 to the development computer, 2-11
 - overview, 2-6
 - required items, 2-1
 - subnets, 2-8
- help
 - professional services, C-1
 - technical support, C-1

I

- IEEE 1394
 - cable, 2-1
 - connector, 3-8
 - licensing, 1-1
- IEEE 1394 bus, available power, B-1
- IEEE 1394 camera
 - connecting to NI 1450, 2-8
 - digital camera specification, 1-1
- IEEE 1394a (table), 3-6
- image acquisition
 - LabVIEW RT, 2-17
 - Vision Builder AI, 2-14
- inductive loads, protecting, 4-13

- inputs
 - general-purpose, 4-8
 - TTL, 4-2
- installation category descriptions, 2-5
- instrument drivers, C-1
- IP address
 - configuring with Vision Builder AI, 2-13
 - configuring with Vision Development Module, 2-16
- IP RESET DIP switch, 3-5
- isolated input, sourcing output device, 4-11
- isolated output, external load, 4-11

K

- KnowledgeBase, C-1

L

- label, MAC address, serial number, 5-2
- LabVIEW RT
 - acquiring images, 2-17
 - description, 1-5
 - installing, 2-15
- LabVIEW, installing, 2-15
- latch, 4-7
- LEDs
 - diagram, 3-1
 - POWER OK, 3-2
 - STATUS, 3-2

M

- MAC address, 5-2
- MAX, 2-16
- Measurement & Automation Explorer (MAX), 2-16
- media access control address, 5-2
- memory, specifications, B-1
- mounting kits, part numbers, 2-2

N

- National Instruments
 - calibration certificate, C-2
 - customer education, C-1
 - Declaration of Conformity, C-1
 - professional services, C-1
 - system integration services, C-1
 - technical support, C-1
 - worldwide offices, C-2
- network
 - connecting, 2-7
 - subnet, 2-8
- network specifications, B-1
- NI 1450 hardware
 - connecting multiple NI 1450 systems (diagram), 5-1
 - connecting to development computer, 2-11
 - connectors (table), 3-6
 - DIP switches, overview, 3-3
 - IEEE 1394 connector, 3-8
 - optional hardware, 2-2
 - overview, 1-1
 - parts locator, 1-2
- NI-IMAQ for IEEE 1394 Cameras
 - driver software, 1-4
 - installing, 2-13
- NO APP DIP switch, 3-5

O

- online technical support, C-1
- outputs
 - general-purpose, 4-8
 - TTL, 4-2

P

- parts locator, 1-2
- phone technical support, C-2
- physical characteristic specifications, B-3

- POWER OK LED, 3-2
 - power requirements specifications, B-1
 - power supply
 - connector, 3-6, 3-7
 - connector (table), 3-6
 - desktop, 2-1
 - earth ground, 3-7
 - separate main supply, 2-10
 - terminals (table), 3-7
 - wiring power, 2-9
 - wiring power (diagram), 2-10
 - product selection port, 4-7
 - (table), 4-8
 - professional services, C-1
 - programming examples, C-1
 - pulse delay, 4-5
 - pulse modes, 4-5
 - pulse width, 4-5
- Q**
- quadrature encoder, 4-6
- R**
- required hardware, 2-1
- S**
- SAFE MODE DIP switch, 3-4
 - safety information, 2-4
 - safety specifications, B-4
 - serial number, 5-2
 - serial port, connector (table), 3-6
 - setup
 - multiple NI 1450s, 5-1
 - typical single-camera, 4-14
 - setup and configuration, 2-1
 - shutdown, 4-9
 - shutdown, disabling, 4-10
- software
 - application, 1-4, 1-5
 - installing on development computer, 2-13
 - NI-IMAQ for IEEE 1394 Cameras, 1-4
 - software choices, 1-4
 - software drivers, C-1
 - sourcing output device
 - wiring, 4-11
 - diagram, 4-12
 - specifications
 - electromagnetic compatibility, B-4
 - environmental, B-4
 - memory, B-1
 - network, B-1
 - optically isolated inputs, B-2
 - optically isolated outputs, B-3
 - outputs, B-3
 - physical characteristics, B-3
 - power requirements, B-1
 - safety, B-4
 - TTL inputs, B-2
 - TTL outputs, B-2
 - STATUS LED, 3-2
 - STATUS LED error indications (table), A-3
 - subnet, 2-8, 5-2
 - support, technical, C-1
 - system integration services, C-1
- T**
- technical support, C-1
 - telephone technical support, C-2
 - terminal block, 37-pin (table), 3-12
 - timed pulse output, 4-4
 - timed pulse output, initiating, 4-4
 - training, customer, C-1
 - transmission line effects, 4-13
 - TRIG 0
 - cable, 3-11
 - connector (table), 3-6

TRIG 1

- cable, 3-11
- connector (table), 3-6

TRIG 2

- cable, 3-11
- connector (table), 3-6

trigger input lines, 4-3

trigger polarity, 4-5

troubleshooting

- hardware, A-2
- software, A-1
- STATUS LED error indications (table), A-3

troubleshooting resources, C-1

V**VGA**

- connector (table), 3-6
- connector signals (table), 3-9

VGA connector (diagram), 3-9

video formats, 1-3

Vision Builder AI

- configuring IP address, 2-13
- description, 1-5
- image acquisition, 2-14
- installing, 2-13

Vision Development Module

- configuring IP address, 2-16
- description, 1-5
- image acquisition, 2-17
- installing, 2-15

W**Web**

- professional services, C-1
- technical support, C-1
- worldwide technical support, C-2