

## COMPREHENSIVE SERVICES

We offer competitive repair and calibration services, as well as easily accessible documentation and free downloadable resources.

## SELL YOUR SURPLUS

We buy new, used, decommissioned, and surplus parts from every NI series. We work out the best solution to suit your individual needs.

 Sell For Cash    Get Credit    Receive a Trade-In Deal

## OBSOLETE NI HARDWARE IN STOCK & READY TO SHIP

We stock **New**, **New Surplus**, **Refurbished**, and **Reconditioned** NI Hardware.



*Bridging the gap between the manufacturer and your legacy test system.*

 1-800-915-6216

 [www.apexwaves.com](http://www.apexwaves.com)

 [sales@apexwaves.com](mailto:sales@apexwaves.com)

*All trademarks, brands, and brand names are the property of their respective owners.*

**Request a Quote**

 **CLICK HERE**

**NI-9230**

## GETTING STARTED GUIDE

# NI 9230

3 AI,  $\pm 30$  V, 24 Bit, 12.8 kS/s/ch Simultaneous

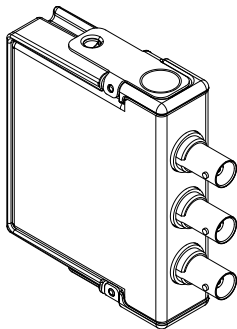
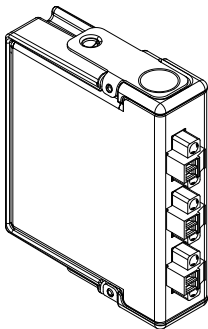

This document explains how to connect to the NI 9230. In this document, the NI 9230 with screw terminal and the NI 9230 with BNC are referred to inclusively as the NI 9230.



**Note** Before you begin, complete the software and hardware installation procedures in your chassis documentation.



**Note** The guidelines in this document are specific to the NI 9230. The other components in the system might not meet the same safety ratings. Refer to the documentation for each component in the system to determine the safety and EMC ratings for the entire system.

## Safety Guidelines

---

Operate the NI 9230 only as described in this document.



**Caution** Do not operate the NI 9230 in a manner not specified in this document. Product misuse can result in a hazard. You can compromise the safety protection built into the product if the product is damaged in any

way. If the product is damaged, return it to NI for repair.

## Safety Voltages

Connect only voltages that are within the following limits.

Isolation	
Channel-to-channel	None
Channel-to-earth ground	
Continuous	60 VDC, Measurement Category I
Withstand	1,000 Vrms, verified by a 5 s dielectric withstand test

Measurement Category I is for measurements performed on circuits not directly connected to the electrical distribution system referred to as *MAINS* voltage. *MAINS* is a hazardous live electrical supply system that powers equipment. This category is for measurements of voltages from specially protected secondary circuits. Such voltage measurements include signal levels, special equipment, limited-energy parts of equipment, circuits powered by regulated low-voltage sources, and electronics.



**Caution** Do not connect the NI 9230 to signals or use for measurements within Measurement Categories II, III, or IV.



**Note** Measurement Categories CAT I and CAT O are equivalent. These test and measurement circuits are not intended for direct connection to the MAINS building installations of Measurement Categories CAT II, CAT III, or CAT IV.

## Safety Guidelines for Hazardous Locations

The NI 9230 is suitable for use in Class I, Division 2, Groups A, B, C, D, T4 hazardous locations; Class I, Zone 2, AEx nA IIC T4 and Ex nA IIC T4 hazardous locations; and nonhazardous locations only. Follow these guidelines if you are installing the NI 9230 in a potentially explosive environment. Not following these guidelines may result in serious injury or death.



**Caution** Do not disconnect I/O-side wires or connectors unless power has been switched off or the area is known to be nonhazardous.



**Caution** Do not remove modules unless power has been switched off or the area is known to be nonhazardous.



**Caution** Substitution of components may impair suitability for Class I, Division 2.



**Caution** For Division 2 and Zone 2 applications, install the system in an enclosure rated to at least IP54 as defined by IEC/EN 60079-15.



**Caution** For Division 2 and Zone 2 applications, connected low impedance sources must include a protection device installed between the source and the AI terminals. The protection device must prevent the AI+ to AI- voltage from exceeding 42 V if there is a transient overvoltage condition.



**Caution** For Division 2 and Zone 2 applications, connected signals must be within the following limits.

---

Capacitance

0.08  $\mu$ F max

---

## Special Conditions for Hazardous Locations Use in Europe and Internationally

The NI 9230 has been evaluated as Ex nA IIC T4 Gc equipment under DEMKO Certificate No. 12 ATEX 1202658X and is IECEx UL 14.0089X certified. Each NI 9230 is marked  II 3G and is suitable for use in Zone 2 hazardous locations, in ambient temperatures of  $-40\text{ }^{\circ}\text{C} \leq T_a \leq 70\text{ }^{\circ}\text{C}$ . If you are using the NI 9230 in Gas Group IIC hazardous locations, you must use the device in an NI chassis that has been evaluated as Ex nC IIC T4, Ex IIC T4, Ex nA IIC T4, or Ex nL IIC T4 equipment.



**Caution** You must make sure that transient disturbances do not exceed 140% of the rated voltage.



**Caution** The system shall only be used in an area of not more than Pollution Degree 2, as defined in IEC 60664-1.



**Caution** The system shall be mounted in an ATEX/IECEx-certified enclosure with a minimum ingress protection rating of at least IP54 as defined in IEC/EN 60079-15.



**Caution** The enclosure must have a door or cover accessible only by the use of a tool.

## Electromagnetic Compatibility Guidelines

---

This product was tested and complies with the regulatory requirements and limits for electromagnetic compatibility (EMC) stated in the product specifications. These requirements and limits provide reasonable protection against harmful interference when the product is operated in the intended operational electromagnetic environment.

This product is intended for use in industrial locations. However, harmful interference may occur in some installations, when the product is connected to a peripheral device or test object, or if the product is used in residential or commercial areas. To minimize interference with radio and television reception and prevent unacceptable performance degradation, install and use this product in strict accordance with the instructions in the product documentation.



Furthermore, any changes or modifications to the product not expressly approved by National Instruments could void your authority to operate it under your local regulatory rules.



**Caution** To ensure the specified EMC performance, operate this product only with shielded cables and accessories. Do not use unshielded cables or accessories unless they are installed in a shielded enclosure with properly designed and shielded input/output ports and connected to the product using a shielded cable. If unshielded cables or accessories are not properly installed and shielded, the EMC specifications for the product are no longer guaranteed.



**Caution** Electrostatic Discharge (ESD) can damage the NI 9230. To prevent damage, use industry-standard ESD prevention measures during installation, maintenance, and operation.



**Caution** To ensure the specified EMC performance for the NI 9230 with screw terminal, you must install clamp-on ferrite beads (part number 782802-01) in accordance with the product installation instructions.

Refer to the NI 9230 product page on [ni.com](https://ni.com) for purchasing information about clamp-on ferrite beads.



**Caution** To ensure the specified EMC performance, the length of all I/O cables must be no longer than 30 m (100 ft).

## Cable Requirements for EMC Compliance

Select and install cables for the NI 9230 in accordance with the following requirements:

- Connect the cable shield to the chassis ground (grounding screw of the chassis).
- For the NI 9230 with screw terminal, install a clamp-on ferrite bead (part number 782802-01) on the input cable for each channel that you are connecting to on the NI 9230.
- For the NI 9230 with screw terminal, clamp-on ferrite beads must be installed on the cable as close to the module as possible. Placing the ferrite elsewhere on the cable noticeably impairs its effectiveness.

**Figure 1.** Cable Connections for EMC Compliance

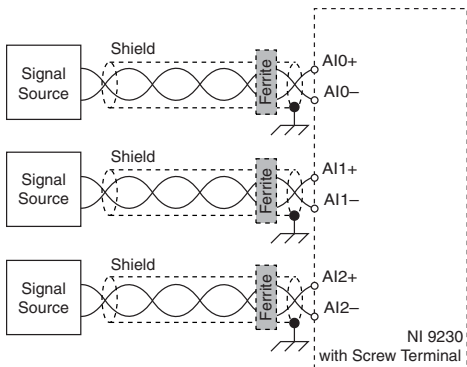

## Special Conditions for Marine Applications

Some products are Lloyd's Register (LR) Type Approved for marine (shipboard) applications. To verify Lloyd's Register certification for a product, visit [ni.com/certification](http://ni.com/certification) and search for the LR certificate, or look for the Lloyd's Register mark on the product.



**Caution** In order to meet the EMC requirements for marine applications, install the product in a shielded enclosure with shielded and/or filtered power and input/output ports. In addition, take precautions when designing, selecting, and installing measurement probes and cables to ensure that the desired EMC performance is attained.

## Preparing the Environment

---

Ensure that the environment in which you are using the NI 9230 meets the following specifications.

---

Operating temperature (IEC 60068-2-1, IEC 60068-2-2)	-40 °C to 70 °C
Operating humidity (IEC 60068-2-78)	10% RH to 90% RH, noncondensing
Pollution Degree	2
Maximum altitude	5,000 m

---

Indoor use only.



**Note** Refer to the device datasheet on [ni.com/manuals](https://ni.com/manuals) for complete specifications.

## Connecting the NI 9230

---

The NI 9230 provides connections to three simultaneously sampled analog input channels.

**Figure 2.** NI 9230 Pinout

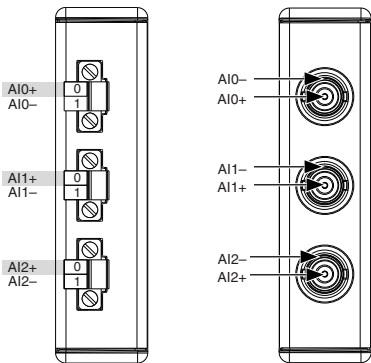

**Note** You must use 2-wire ferrules to create a secure connection when connecting more than one wire to a single terminal on the NI 9230 with screw terminal.

Each channel has a terminal to which you can connect a signal source. The AI+ terminal of the connector provides the DC excitation, when enabled, and the positive input signal

connection. The AI- terminal provides the excitation return path and the signal ground reference.

**Table 1.** Signal Descriptions

Signal	Description
AI+	Positive analog input signal connection
AI-	Negative analog input signal connection

## Connecting Signal Sources

You can connect ground-referenced or floating signal sources to the NI 9230.

If you make a ground-referenced connection between the signal source and the NI 9230, make sure the voltage on the AI+ and the AI- connections are in the channel-to-earth safety voltage range to ensure proper operation of the NI 9230. Refer to the device datasheet on [ni.com/manuals](https://ni.com/manuals) for more information about operating voltages and overvoltage protection.

**Figure 3.** Connecting a Grounded Signal Source

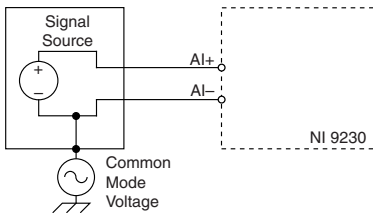

**Figure 4.** Connecting a Floating Signal Source

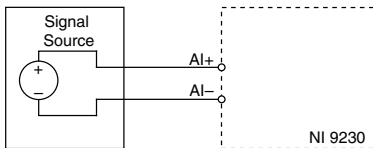

## Integrated Electronic Piezoelectric (IEPE) Sensors

The NI 9230 provides an IEPE excitation current for each channel to measure the IEPE sensors. Typical IEPE sensors have



a case that is electrically isolated from the IEPE electronics. As a result, connecting the sensor to the NI 9230 results in a floating connection even though the case of the sensor is grounded.

## Wiring for High-Vibration Applications

---

If your application is subject to high vibration, NI recommends that you follow these guidelines to protect connections to the NI 9230 with screw terminal:

- Use ferrules to terminate wires to the detachable connector.
- Use the NI 9971 backshell kit.

# Where to Go Next

---

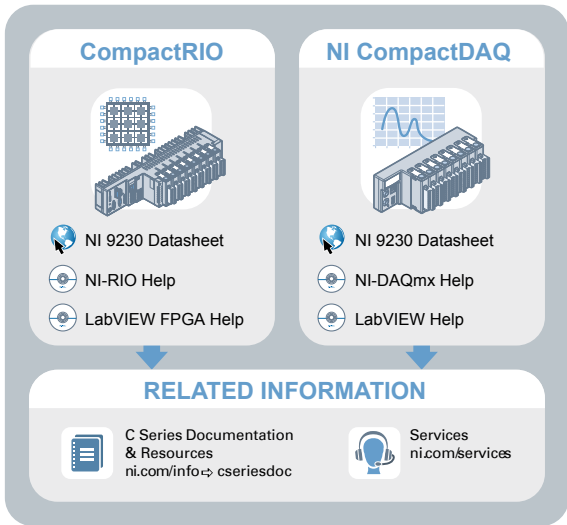

Located at [ni.com/manuals](http://ni.com/manuals)

Installs with the software

## Worldwide Support and Services

---

The NI website is your complete resource for technical support. At [ni.com/support](https://ni.com/support), you have access to everything from troubleshooting and application development self-help resources to email and phone assistance from NI Application Engineers.

Visit [ni.com/services](https://ni.com/services) for NI Factory Installation Services, repairs, extended warranty, and other services.

Visit [ni.com/register](https://ni.com/register) to register your NI product. Product registration facilitates technical support and ensures that you receive important information updates from NI.

A Declaration of Conformity (DoC) is our claim of compliance with the Council of the European Communities using the manufacturer's declaration of conformity. This system affords the user protection for electromagnetic compatibility (EMC) and product safety. You can obtain the DoC for your product by visiting [ni.com/certification](https://ni.com/certification). If your product supports calibration, you can obtain the calibration certificate for your product at [ni.com/calibration](https://ni.com/calibration).

NI corporate headquarters is located at 11500 North Mopac Expressway, Austin, Texas, 78759-3504. NI also has offices located around the world. For telephone support in the United States, create your service request at [ni.com/support](https://ni.com/support) or dial 1 866 ASK MYNI (275 6964). For telephone support outside the United States, visit the *Worldwide Offices* section of [ni.com/niglobal](https://ni.com/niglobal) to access the branch office websites, which provide up-to-date contact information, support phone numbers, email addresses, and current events.

Refer to the *NI Trademarks and Logo Guidelines* at [ni.com/trademarks](http://ni.com/trademarks) for information on NI trademarks. Other product and company names mentioned herein are trademarks or trade names of their respective companies. For patents covering NI products/technology, refer to the appropriate location: **Help»Patents** in your software, the `patents.txt` file on your media, or the *National Instruments Patent Notice* at [ni.com/patents](http://ni.com/patents). You can find information about end-user license agreements (EULAs) and third-party legal notices in the readme file for your NI product. Refer to the *Export Compliance Information* at [ni.com/legal/export-compliance](http://ni.com/legal/export-compliance) for the NI global trade compliance policy and how to obtain relevant HTS codes, ECCNs, and other import/export data. NI MAKES NO EXPRESS OR IMPLIED WARRANTIES AS TO THE ACCURACY OF THE INFORMATION CONTAINED HEREIN AND SHALL NOT BE LIABLE FOR ANY ERRORS. U.S. Government Customers: The data contained in this manual was developed at private expense and is subject to the applicable limited rights and restricted data rights as set forth in FAR 52.227-14, DFAR 252.227-7014, and DFAR 252.227-7015.

© 2015 National Instruments. All rights reserved.