

COMPREHENSIVE SERVICES

We offer competitive repair and calibration services, as well as easily accessible documentation and free downloadable resources.

SELL YOUR SURPLUS

We buy new, used, decommissioned, and surplus parts from every NI series. We work out the best solution to suit your individual needs.

 Sell For Cash  Get Credit  Receive a Trade-In Deal

OBSOLETE NI HARDWARE IN STOCK & READY TO SHIP

We stock **New**, **New Surplus**, **Refurbished**, and **Reconditioned** NI Hardware.



Bridging the gap between the manufacturer and your legacy test system.

 1-800-915-6216

 www.apexwaves.com

 sales@apexwaves.com

All trademarks, brands, and brand names are the property of their respective owners.

Request a Quote

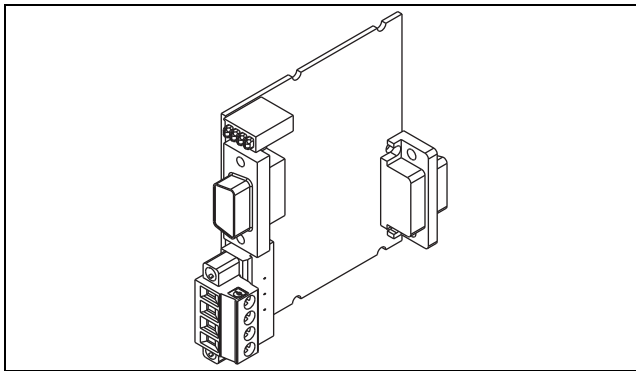
 **CLICK HERE**

NI-9505

OPERATING INSTRUCTIONS AND SPECIFICATIONS

NI 9505E

DC Brushed Servo Drive



This document describes how to use the National Instruments 9505E module and includes dimensions, pin assignments, and specifications for the NI 9505E DC brushed servo drive. Visit ni.com/info and enter `rdsoftwareversion` to determine which software you need for the modules you are using. For information about installing, configuring, and programming the system, refer to the system documentation. Visit ni.com/info and enter `cseriesdoc` for information about C Series documentation.



Caution National Instruments makes no electromagnetic compatibility (EMC) or CE marking compliance claims for the NI 9505E. The end-product supplier is responsible for conformity to any and all compliance requirements.



Caution The NI 9505E must be installed inside a suitable enclosure prior to use. Hazardous voltages may be present.

NI 9505E Dimensions

The following figure shows the dimensions of the NI 9505E.

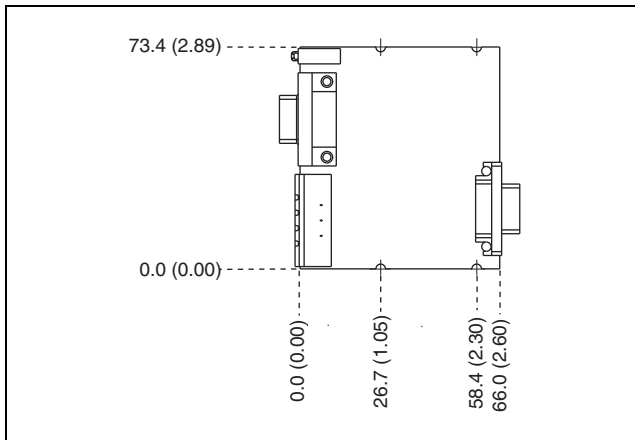


Figure 1. NI 9505E Dimensions in Millimeters (Inches)

NI 9505E Hardware Overview

The NI 9505E provides unique flexibility and customization. The NI 9505E works together with the LabVIEW FPGA Module to create a highly customizable motor drive or actuator amplifier. Figure 2 illustrates the functionality of the NI 9505E working in conjunction with the LabVIEW FPGA Module in a typical motion control application. Figures 3 and 4 show more detailed versions of the position, velocity, and current loops implemented in the LabVIEW FPGA Module. A typical application contains a position loop, velocity loop, and current loop, implemented in the LabVIEW FPGA Module block diagram. Depending on the application, you may not need to use all three loops. The examples installed in the `labview\examples\CompactRIO\Module Specific\NI 9505` directory illustrate methods for implementing each of these loops.

The NI 9505E returns the motor or actuator current data to the LabVIEW FPGA Module for use in a current loop or for monitoring. The NI 9505E also returns status information such as drive fault status, V_{SUP} presence, and emergency stop status to the LabVIEW FPGA Module for use in system monitoring. Refer to the *NI 9505 Reference Help* book in the *LabVIEW Help*,

available by selecting **Help»Search the LabVIEW Help**, for more information about the available status information.

The LabVIEW FPGA Module generates a PWM signal and sends the signal to the NI 9505E. The PWM signal is proportional to the desired current or torque you want to provide to the motor or actuator. Increasing the PWM duty cycle results in increased current and thus increased torque.

Quadrature encoder signals pass through the NI 9505E and are processed in the LabVIEW FPGA Module for use in the position and velocity loops. Refer to Figure 5 for a typical NI 9505E connection example, including encoder and E-Stop inputs.

For more advanced motion control applications, NI SoftMotion provides functions for trajectory generation, spline interpolation, position and velocity PID control, and encoder implementation using both the LabVIEW Real-Time Module and the LabVIEW FPGA Module. With NI SoftMotion you can create a custom motion controller without the need to develop the trajectory generator or spline engine yourself. Refer to the `labview\examples\CompactRIO\Module Specific\NI 9505` directory for example VIs using the NI 9505E and NI SoftMotion.

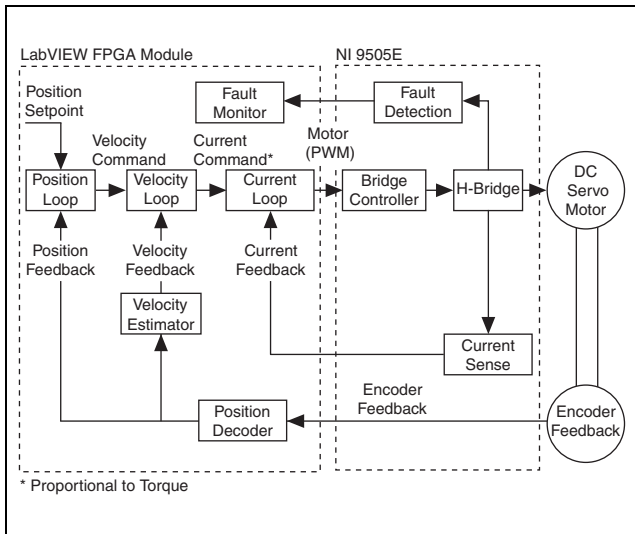


Figure 2. NI 9505E Block Diagram

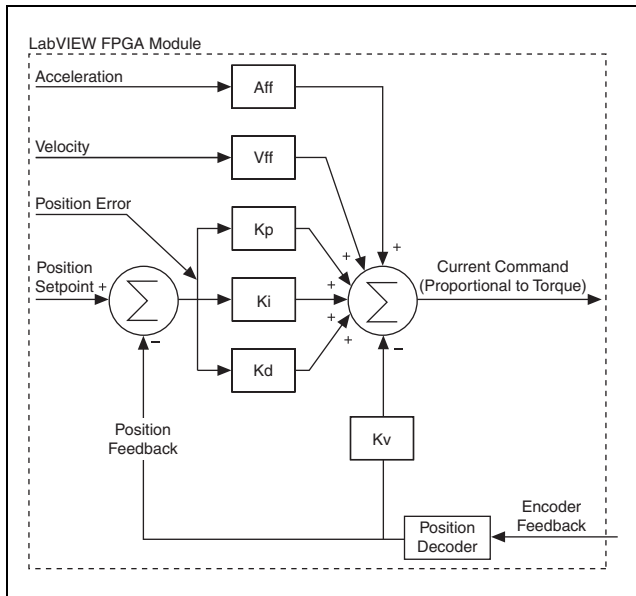


Figure 3. LabVIEW FPGA Module NI 9505E PID Loop

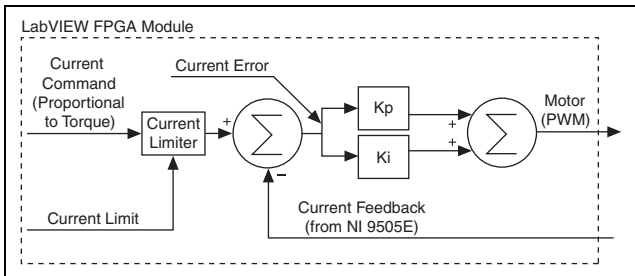


Figure 4. LabVIEW FPGA Module NI 9505E Current Loop

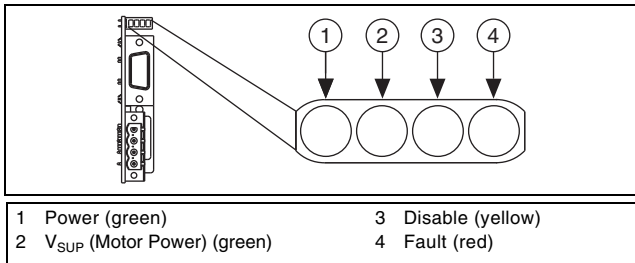
Hot-Swap Behavior

The NI 9505E is always disabled when it is inserted in the chassis, regardless of whether V_{SUP} is present or not. You can enable the drive using the **Enable Drive** method in software. Refer to the *NI 9505 Reference Help* book in the *LabVIEW Help*, available by selecting **Help»Search the LabVIEW Help**, for more information about enabling the drive.

When the NI 9505E is removed from the chassis while it is enabled, the power to the motor is removed and the motor decelerates to a stop based on its own friction.

LED Indicators

The NI 9505E has four LEDs to display status information.



Power

The Power LED (green) illuminates when the NI 9505E is properly inserted into a powered chassis.



Note The Power LED does not illuminate when the chassis is in sleep mode.

V_{SUP}

The V_{SUP} LED (green) illuminates when the motor DC power supply is properly connected and powering the drive.

Disable

The Disable LED (yellow) illuminates when the drive is disabled. The drive is disabled by default at power-on. You can enable the drive using the **Enable Drive** method in software. Refer to the *NI 9505 Reference Help* book in the *LabVIEW Help*, available by selecting **Help»Search the LabVIEW Help**, for more information about this method.

Fault



Caution If the Fault LED is lit, determine the cause of the fault and correct it before enabling the drive.

The Fault LED (red) illuminates when a fault occurs. A fault disables the drive. Causes for fault are the following:



Caution V_{SUP} greater than 40 V will result in damage to the NI 9505E.

- Overvoltage
- Undervoltage

- Motor terminal (MOTOR±) short to V_{SUP}
- Motor terminal (MOTOR±) short to COM
- Module temperature exceeds 115 °C
- Sending commands to the motor before enabling the drive



Note Do not command motor movement until the drive is enabled with the **Enable Drive** method. Attempting to control the motor before it is enabled will result in a fault.

- Violating PWM minimum pulse width requirements. Refer to the *Specifications* section for more information about PWM.

Sleep Mode

This module supports a low-power sleep mode. Support for sleep mode at the system level depends on the chassis that the module is plugged into. Refer to the chassis manual for information about support for sleep mode. If the chassis supports sleep mode, refer to the software help for information about enabling sleep mode. Visit ni.com/info and enter `cseriesdoc` for information about C Series documentation.

Typically, when a system is in sleep mode, you cannot communicate with the modules. In sleep mode, the system consumes minimal power and may dissipate less heat than it does

in normal mode. Refer to the *Specifications* section for more information about power consumption and thermal dissipation.



Note The Power LED does not illuminate when the chassis is in sleep mode.

Wiring the NI 9505E

The NI 9505E has a 9-pin female DSUB connector that provides connections for the encoder inputs, a +5 V connection for encoder power, a connection for an emergency stop input, and a connection to COM. Refer to Table 1 for the pin assignments.

The NI 9505E also has a screw-terminal connector that provides connections to a motor DC power supply and a DC brushed servo motor. Connect the positive lead of the power supply to terminal 4, V_{SUP} , and the negative lead to terminal 3, COM. Refer to Table 2 for the terminal assignments.



Note You must use 2-wire ferrules to create a secure connection when connecting more than one wire to a single terminal on the NI 9505E screw-terminal.



Caution Do *not* turn on or plug in the motor DC power supply until the screw-terminal connector is fully inserted.

Table 1. NI 9505E DSUB Pin Assignments

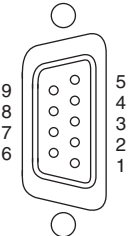
Connector	Pin	Signal
	1	Encoder Phase A+
	2	Encoder Phase B+
	3	Encoder Index+ (Phase Z+)
	4	Emergency Stop (E-Stop)
	5	+5 V (output)
	6	Encoder Phase A-
	7	Encoder Phase B-
	8	Encoder Index- (Phase Z-)
	9	Common (COM)

Table 2. NI 9505E Screw-Terminal Terminal Assignments

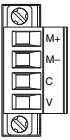
Module	Terminal	Signal
	M+	MOTOR+
	M-	MOTOR-
	C	COM (motor DC power supply reference)
	V	V _{SUP} (motor DC power supply)

Figure 5 shows a typical NI 9505E connection example, including encoder and E-Stop inputs.

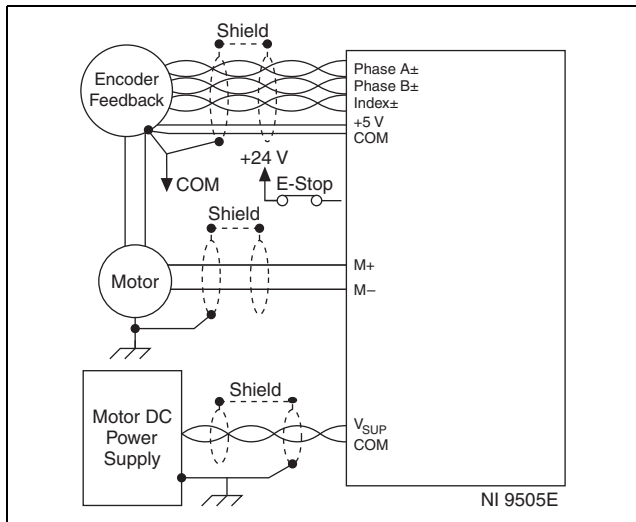


Figure 5. NI 9505E Connections

Optional Screw-Terminal Accessory

Use the NI 9931 Screw-Terminal Accessory instead of the detachable screw-terminal connector to increase the output power of the module at temperatures below 85 °C. The NI 9931 is available from ni.com (NI part number 780571-01) or by calling your National Instruments sales representative. Refer to the [Specifications](#) section for more information. Refer to Figure 6 for an illustration.

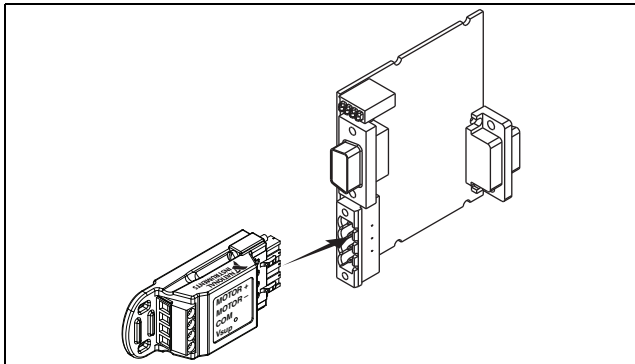


Figure 6. NI 9505E Module with Optional Screw-Terminal Accessory

Motor Power Signals

The MOTOR+ and MOTOR– signals power the servo motor. Motor direction is as follows:

- **Forward**—Clockwise (CW) facing motor shaft
- **Reverse**—Counterclockwise (CCW) facing motor shaft

Figure 7 shows clockwise and counterclockwise motor rotation.

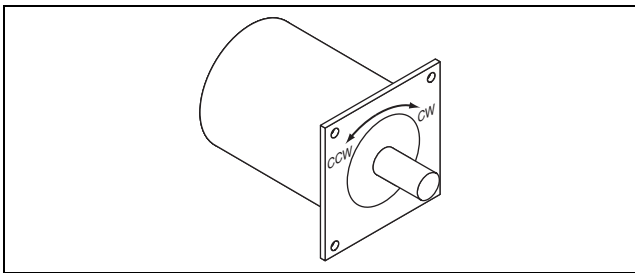


Figure 7. Clockwise and Counterclockwise Motor Rotation



Tip If the motor does not turn in the desired direction, reverse the MOTOR+ and MOTOR– signals.

Encoder Signals

The encoder signals consist of a Phase A, Phase B, and Index (Phase Z) input. The NI 9505E supports differential and single-ended inputs for Phase A, Phase B, and Index (Phase Z) signals. Figures 8 and 9 show simplified schematic diagrams of the encoder input circuit connected to differential and single-ended inputs. You can also accommodate open-collector output encoders by using a 1 k Ω pull-up resistor on each line to +5 VDC. Refer to the *Specifications* section for more information about the encoder inputs.

The encoder signals are raw digital input signals. These signals are used in the LabVIEW FPGA Module for position and/or velocity feedback. Figures 2 and 3 illustrate the use of the encoder signals in a position and velocity loop in the LabVIEW FPGA Module. Refer to the examples installed at `labview\examples\CompactRIO\Module Specific\NI 9505` for examples of using the encoder signals. Refer to the *NI 9505 Reference Help* book in the *LabVIEW Help*, available by selecting **Help»Search the LabVIEW Help**, for more information.

If the encoder cable length is greater than 3.05 m (10 ft), use encoders with differential line driver outputs for your applications. Power for a +5 V encoder—generated by a power supply on the NI 9505E—is available on pin 5 of the DSUB connector.

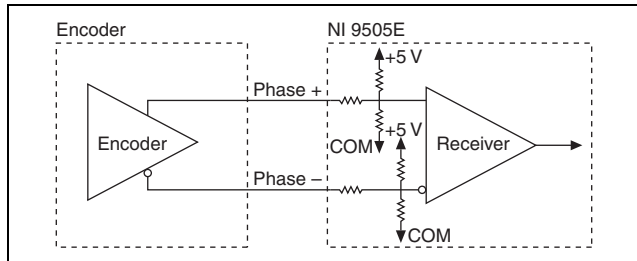


Figure 8. Differential Encoder Input Circuit

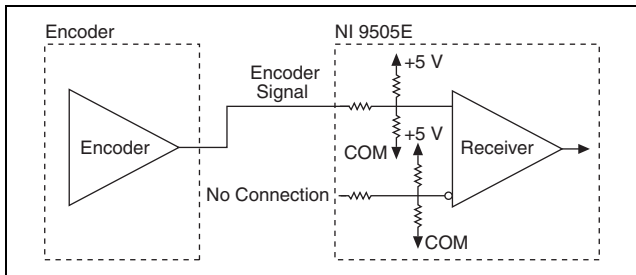


Figure 9. Single-Ended Encoder Input Circuit

Closed-loop servo applications require consistent directional polarity between the motor and encoder for correct operation. One industry-standard directional polarity is as follows:

- Positive = forward = clockwise (CW) facing motor shaft
- Negative = reverse = counterclockwise (CCW) facing motor shaft

Refer to Figure 7 for a depiction of clockwise and counterclockwise rotation. If encoder counting does not behave as expected, change the encoder polarity in the FPGA or swap the Phase A and Phase B connections.

When connecting the encoder wiring to the NI 9505E, use shielded wire of at least 24 AWG. You must use cables with twisted pairs and an overall shield for improved noise immunity. Refer to Figure 5 for a connection example.



Note Using an unshielded cable may produce noise, which can corrupt the encoder signals and cause lost counts, reduced accuracy, or other erroneous encoder and drive operation.

Emergency Stop Signal

The E-Stop signal is an input to the drive from an emergency stop switch. Figure 10 shows a simplified schematic of the emergency stop input circuit. When the emergency stop switch is closed, current flows through the circuit, and the drive is enabled. When an external event activates the emergency stop switch, the switch opens and current stops flowing, disabling the drive. The E-Stop functionality is disabled by default. Refer to the *NI 9505 Reference Help* book in the *LabVIEW Help*, available by selecting **Help» Search the LabVIEW Help**, for information about how to enable this signal using the **Enable E-Stop** Property.

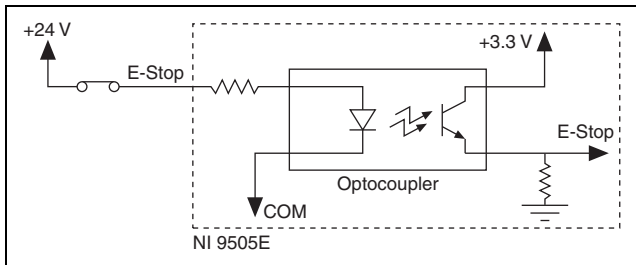


Figure 10. Emergency Stop Input Circuit

Cable Requirements for EMC Compliance

Use the following guidelines when selecting cables for the NI 9505E:

- Use shielded cables with a low impedance connection to chassis ground to minimize noise and signal crosstalk.
- Tie the V_{SUP} cable shield to chassis ground at the module side only.
- Tie the motor cable shield to chassis ground at the motor side only.

- Tie the encoder cable shield to COM at the encoder side only.
- Wire encoder signals and their ground connections separately from all other connections to prevent lost encoder counts.
- Route wires along the machine frame to reduce high frequency noise.
- Add clamp-on ferrites to cables to further reduce emissions.
- Add a balun to the power cable to attenuate conducted and radiated emissions.

Using the NI 9505E with Other C Series Modules

Due to additional ambient heating of the NI 9505E when supplying more than 1 A to the load, the room temperature (25 °C, ± 5 °C) specifications of adjacent modules are not valid. The full operating temperature (−40 °C to 85 °C) specifications for these modules are still valid.

Specifications

The following specifications are typical for the range -40 to 85 °C internal to any enclosures and at a PWM rate of 20 kHz unless otherwise noted. All voltages are relative to COM unless otherwise noted.

Operating Conditions

Motor DC power supply (V_{SUP}) +8 to +30 VDC, 12 A max

Motor continuous current¹

(Motor \pm) 1 A @ 85 °C
5 A @ 40 °C

With NI 9931

screw-terminal accessory 1 A @ 85 °C
7.3 A @ 40 °C

Peak current² 12 A < 2 s max

¹ For more information about maximum continuous current at temperatures less than 85 °C, visit ni.com/info and enter `rdmot2`.

² Allow at least 3.4 s between peak current intervals.

PWM

Rate..... 20 kHz recommended,
40 kHz max



Caution Violating minimum pulse width will result in unpredictable performance.

Minimum pulse width
(high or low)..... 2 μ s

Drive direction update rate Nominally 20 μ s

Current loop

ADC resolution 12 bits

Current range..... ± 12.7 A

Maximum update rate..... 20 μ s

Minimum inductance 500 μ H

MTBF 821,178 hours at 25 °C;
Bellcore Issue 2, Method 1,
Case 3, Limited Part Stress
Method



Note Contact NI for Bellcore MTBF specifications at other temperatures or for MIL-HDBK-217F specifications.

Drive Protection

Undervoltage..... <6 V



Caution V_{SUP} greater than 40 V will result in damage to the module.

Overvoltage..... >32 V

Reverse polarity -30 V

Motor terminal (MOTOR±)

short to ground..... Yes

Motor terminal (MOTOR±)

short to V_{SUP} Yes

Temperature fault trip point 115 °C (module temperature)

Encoder Input Characteristics

Number of inputs 3

Input type Differential or single-ended

Voltage range 0 to 5.5 VDC

Digital logic levels

Single-ended..... TTL compatible

Input high threshold 2.4 V

Input low threshold 0.8 V

Differential

Input threshold ± 700 mV,
line driver compatible

Common-mode voltage..... -7 to 12 V

Input current ± 1 mA

Maximum quadrature frequency..... 5 MHz

E-Stop Input

Input voltage range 0 to 30 V

Input ON voltage 3.5 to 30 V

Input OFF voltage 0 to 2 V

Turn-on current 500 μ A, typical
1 mA, maximum

Power Requirements

Power consumption from chassis

Active mode 100 mW max

Sleep mode 0.4 mW max

Thermal dissipation (at 85 °C)

Active mode 1.5 W max

Sleep mode 0.4 mW max

Encoder Power Supply

5 V regulated output

Voltage tolerance 5 V $\pm 5\%$, $V_{SUP} \geq 8$ V

Current..... 125 mA

Physical Characteristics

Use a dry, low-velocity stream of air to clean the module. If needed, use a soft-bristle brush for cleaning around components.



Note For two-dimensional drawings and three-dimensional models of the C Series module and connectors, visit ni.com/dimensions and search by module number.

Screw-terminal wiring	12 to 24 AWG copper conductor wire with 10 mm (0.39 in.) of insulation stripped from the end
Torque for screw-terminals	0.5 to 0.6 N · m (4.4 to 5.3 lb · in.)
Ferrules	0.25 mm ² to 2.5 mm ²
Weight (without screw-terminal)	47 g (1.7 oz)
NI 9931 Screw-Terminal Accessory	
Screw-terminal wiring	14 to 26 AWG copper conductor wire with 7 mm (0.28 in.) of insulation stripped from the end
Torque for screw-terminals.....	0.5 to 0.6 N · m (4.4 to 5.3 lb · in.)
Ferrules	0.25 mm ² to 1.5 mm ²
Weight	40 g (1.4 oz)

Safety

Safety Voltages

Connect only voltages that are within the following limits.

Channel-to-COM 0 to +30 VDC max,
Measurement Category I

Isolation

Channel-to-channel None

Channel-to-earth ground

Continuous 60 VDC,
Measurement Category I,
(Double insulation)

Withstand 750 V_{rms}, verified by a 5 s
dielectric withstand test

Measurement Category I is for measurements performed on circuits not directly connected to the electrical distribution system referred to as *MAINS* voltage. *MAINS* is a hazardous live electrical supply system that powers equipment. This category is for measurements of voltages from specially protected secondary circuits. Such voltage measurements include signal levels, special equipment, limited-energy parts of equipment, circuits powered by regulated low-voltage sources, and electronics.



Caution Do *not* connect the NI 9505E to signals or use for measurements within Measurement Categories II, III, or IV.

Safety Standards

This product meets the requirements of the following standards of safety for electrical equipment for measurement, control, and laboratory use when installed in a suitable enclosure:

- IEC 61010-1, EN 61010-1
- UL 61010-1, CSA 61010-1



Note For UL and other safety certifications, refer to the product label or the *Online Product Certification* section.

Online Product Certification

Refer to the product Declaration of Conformity (DoC) for additional regulatory compliance information. To obtain product certifications and the DoC for this product, visit ni.com/certification, search by module number or product line, and click the appropriate link in the Certification column.

Environmental

National Instruments C Series modules are intended for indoor use only, but may be used outdoors if installed in a suitable enclosure.

Refer to the manual for the chassis you are using for more information about meeting these specifications.

Operating temperature

(IEC 60068-2-1, IEC 60068-2-2) -40 to 85 °C

Storage temperature

(IEC 60068-2-1, IEC 60068-2-2) -40 to 85 °C

Operating humidity

(IEC 60068-2-56)..... 10 to 90% RH,
noncondensing

Storage humidity

(IEC 60068-2-56)..... 5 to 95% RH,
noncondensing

Maximum altitude..... 2,000 m

Pollution Degree 2

Environmental Management

National Instruments is committed to designing and manufacturing products in an environmentally responsible manner. NI recognizes that eliminating certain hazardous substances from our products is beneficial to the environment and to NI customers.

For additional environmental information, refer to the *NI and the Environment* Web page at ni.com/environment. This page contains the environmental regulations and directives with which NI complies, as well as other environmental information not included in this document.

Waste Electrical and Electronic Equipment (WEEE)



EU Customers At the end of their life cycle, all products *must* be sent to a WEEE recycling center. For more information about WEEE recycling centers and National Instruments WEEE initiatives, visit ni.com/environment/weee.

电子信息产品污染控制管理办法（中国 RoHS）



中国客户 National Instruments 符合中国电子信息产品中限制使用某些有害物质指令 (RoHS)。关于 National Instruments 中国 RoHS 合规性信息，请登录 ni.com/environment/rohs_china。(For information about China RoHS compliance, go to ni.com/environment/rohs_china.)

Where to Go for Support

The National Instruments Web site is your complete resource for technical support. At ni.com/support you have access to everything from troubleshooting and application development self-help resources to email and phone assistance from NI Application Engineers.

National Instruments corporate headquarters is located at 11500 North Mopac Expressway, Austin, Texas, 78759-3504. National Instruments also has offices located around the world to help address your support needs. For telephone support in the United States, create your service request at ni.com/support and follow the calling instructions or dial 512 795 8248. For telephone support outside the United States, contact your local branch office:

Australia 1800 300 800, Austria 43 662 457990-0,
Belgium 32 (0) 2 757 0020, Brazil 55 11 3262 3599,
Canada 800 433 3488, China 86 21 5050 9800,
Czech Republic 420 224 235 774, Denmark 45 45 76 26 00,
Finland 358 (0) 9 725 72511, France 01 57 66 24 24,
Germany 49 89 7413130, India 91 80 41190000,
Israel 972 3 6393737, Italy 39 02 41309277, Japan 0120-527196,

Korea 82 02 3451 3400, Lebanon 961 (0) 1 33 28 28,
Malaysia 1800 887710, Mexico 01 800 010 0793,
Netherlands 31 (0) 348 433 466, New Zealand 0800 553 322,
Norway 47 (0) 66 90 76 60, Poland 48 22 328 90 10,
Portugal 351 210 311 210, Russia 7 495 783 6851,
Singapore 1800 226 5886, Slovenia 386 3 425 42 00,
South Africa 27 0 11 805 8197, Spain 34 91 640 0085,
Sweden 46 (0) 8 587 895 00, Switzerland 41 56 2005151,
Taiwan 886 02 2377 2222, Thailand 662 278 6777,
Turkey 90 212 279 3031, United Kingdom 44 (0) 1635 523545

National Instruments, NI, ni.com, and LabVIEW are trademarks of National Instruments Corporation. Refer to the *Terms of Use* section on ni.com/legal for more information about National Instruments trademarks. Other product and company names mentioned herein are trademarks or trade names of their respective companies. For patents covering National Instruments products/technology, refer to the appropriate location: **Help»Patents** in your software, the `patents.txt` file on your media, or the *National Instruments Patent Notice* at ni.com/patents.

© 2009 National Instruments Corp. All rights reserved.

372947A-01

Jul09