

COMPREHENSIVE SERVICES

We offer competitive repair and calibration services, as well as easily accessible documentation and free downloadable resources.

SELL YOUR SURPLUS

We buy new, used, decommissioned, and surplus parts from every NI series. We work out the best solution to suit your individual needs.

 Sell For Cash  Get Credit  Receive a Trade-In Deal

OBSOLETE NI HARDWARE IN STOCK & READY TO SHIP

We stock **New**, **New Surplus**, **Refurbished**, and **Reconditioned** NI Hardware.



Bridging the gap between the manufacturer and your legacy test system.

 1-800-915-6216

 www.apexwaves.com

 sales@apexwaves.com

All trademarks, brands, and brand names are the property of their respective owners.

Request a Quote

 **CLICK HERE**

NI-9516

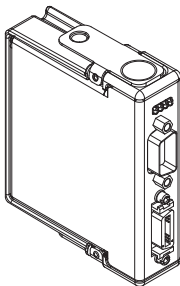
OPERATING INSTRUCTIONS AND SPECIFICATIONS

NI 9516

Servo Drive Interface Module with Feedback

Français Deutsch 日本語 한국어 简体中文

ni.com/manuals



This document describes how to use the National Instruments 9516 module and includes specifications and pin assignments for the NI 9516.



Note The safety guidelines and specifications in this document are specific to the NI 9516. The other components in the system may not meet the same safety ratings and specifications. Refer to the documentation for each component in the system to determine the safety ratings and specifications for the entire system.

Related Information



NI CompactRIO Documentation
ni.com/info ⇨ cseriesdoc



Chassis Compatibility
ni.com/info ⇨ compatibility



Software Support
ni.com/info ⇨ rdsoftwareversion



Services
ni.com/services

Safety Guidelines

Operate the NI 9516 only as described in these operating instructions.

Safety Guidelines for Hazardous Locations

The NI 9516 is suitable for use in Class I, Division 2, Groups A, B, C, D, T4 hazardous locations; Class I, Zone 2, AEx nA IIC T4 and Ex nA IIC T4 hazardous locations; and nonhazardous locations only. Follow these guidelines if you are installing the NI 9516 in a potentially explosive environment. Not following these guidelines may result in serious injury or death.



Caution Do not disconnect I/O-side wires or connectors unless power has been switched off or the area is known to be nonhazardous.



Caution Do not remove modules unless power has been switched off or the area is known to be nonhazardous.



Caution Substitution of components may impair suitability for Class I, Division 2.




Caution For Division 2 and Zone 2 applications, install the system in an enclosure rated to at least IP 54 as defined by IEC/EN 60079-15.



Caution For Division 2 and Zone 2 applications, install a protection device between the input signal and the Vsup pin. The device must prevent the Vsup-to-channel voltage from exceeding 42 V if there is a transient overvoltage condition.

Special Conditions for Hazardous Locations Use in Europe and Internationally

This equipment has been evaluated as Ex nA IIC T4 Gc equipment under DEMKO Certificate No. 07 ATEX 0626664X and is IECEx UL 14.0089X certified. Each module is marked  II 3G and is suitable for use in Zone 2 hazardous locations, in ambient temperatures of $-40\text{ }^{\circ}\text{C} \leq T_a \leq 70\text{ }^{\circ}\text{C}$. If you are using the NI 9516 in Gas Group IIC hazardous locations, you must use the device in an NI chassis that has been evaluated as Ex nC IIC T4, Ex IIC T4, Ex nA IIC T4, or Ex nL IIC T4 equipment.



Caution You must make sure that transient disturbances do not exceed 140% of the rated voltage.



Caution The system shall only be used in an area of not more than Pollution Degree 2, as defined in IEC 60664-1.



Caution The system shall be mounted in an ATEX/IECEX-certified enclosure with a minimum ingress protection rating of at least IP54 as defined in IEC/EN 60079-15.



Caution The enclosure must have a door or cover accessible only by the use of a tool.

Electromagnetic Compatibility Guidelines

This product was tested and complies with the regulatory requirements and limits for electromagnetic compatibility (EMC) as stated in the product specifications. These requirements and limits are designed to provide reasonable protection against harmful interference when the product is operated in its intended operational electromagnetic environment.

This product is intended for use in industrial locations. As such, there is no guarantee that harmful interference will not occur in a particular installation, when the product is connected to a test object, or if the product is used in residential areas. To minimize the potential for the product to cause interference to radio and television reception or to experience unacceptable performance

degradation, install and use this product in strict accordance with the instructions in the product documentation.

Furthermore, any changes or modifications to the product not expressly approved by National Instruments could void your authority to operate it under your local regulatory rules.



Caution To ensure compliance with the applicable regulatory requirements, product installation requires either special considerations or user-installed, add-on devices. See the product installation instructions for further information.



Caution The inputs/outputs of this product can be damaged if subjected to Electrostatic Discharge (ESD). To prevent damage, industry-standard ESD prevention measures must be employed during installation, maintenance, and operation.

Special Conditions for Marine Applications

Some modules are Lloyd's Register (LR) Type Approved for marine applications. To verify Lloyd's Register certification, go to ni.com/certification and search for the LR certificate, or look for the Lloyd's Register mark on the module.



Caution To meet radio frequency emission requirements for marine applications, use shielded cables and install the system in a metal enclosure. Suppression ferrites must be installed on power supply inputs near power entries to modules and controllers. Power supply and module cables must be separated on opposite sides of the enclosure and must enter and exit through opposing enclosure walls.

Connecting the NI 9516

The NI 9516 servo drive interface module is part of a family of C Series motion modules. The module provides servo drive interface signals for a single axis, a full set of motion I/O including inputs for a home switch and limit switches, dual incremental encoder inputs for position feedback and velocity feedback, and 0 to 30 V digital input lines. The NI 9516 also includes a processor to run the spline interpolation engine and PID control loop. Working together they produce smoother motion resulting in precise servo motion control.

System Connection

The NI 9516 has two connectors, a 15-pin DSUB drive interface connector and a 20-pin MDR feedback connector. The 15-pin DSUB includes command signals for interfacing with servo amplifiers or drives, a 0 to 30 V general-purpose digital input line, and a 19 to 30 V input for power connection. Refer to Table 1 for the DSUB connector pin assignments.



Note The remainder of this document does not distinguish between drives and amplifiers. All references to drives also apply to amplifiers.

The 20-pin MDR connector includes dual incremental encoder feedback inputs, a +5 V output for encoder power, home, limit, and position compare inputs, an output for position compare, an additional 19 to 30 V input for power connection, and an additional 0 to 30 V general-purpose digital input line. Refer to Figure 2 for the MDR connector pin assignments.



Note The NI 9516 requires an external power supply. You can connect the external power supply to the V_{sup} input provided on the DSUB or MDR connector. Do not connect more than one external power supply to the module.

NI 9516 Connection Options

National Instruments offers several options for connecting the NI 9516 to servo drives. You can use the NI 9514/16 to AKD cable with the AKD analog servo drive and AKM series servo motors from NI. To connect to third-party servo drives use the NI 951x Cable and Terminal Block Bundle. Refer to Figure 3 for the 37-pin terminal block pin assignments. Refer to the *NI 951x User Manual*, which you can download from ni.com/manuals, for information about additional connection accessories and cabling recommendations.



Tip NI offers AKD analog servo drives and matched servo motors. Refer to *Getting Started with NI 9514/16 C Series Drive Interface Modules and AKD Analog Servo Drives* for installation and configuration information. Refer to the *Getting Started with NI 951x C Series Drive Interface Modules and LabVIEW* for information about using the NI 9516 with other devices.

How to Connect the NI 9516 to Drives and I/O

Complete the following steps to connect the NI 9516 servo drive interface module to drives and other I/O.

1. Install the module in the chassis as specified in the chassis documentation.



Note Refer to the *NI SoftMotion Module* book of the *LabVIEW Help* for information about chassis, slot, or software restrictions.

2. Connect the module to a drive and other I/O using the NI 9514/16 to AKD cable, the NI 951x Cable and Terminal Block Bundle, or a custom cable for direct connectivity to third-party drives.
3. Connect the NI 9516 module to an external power supply.



Caution Do *not* connect anything to pins marked Reserved.



Caution The 37-pin terminal block has separate V_{sup} and COM terminals for each connector. Make sure you are using the correct V_{sup} and COM terminals for the connector you are using. All signals associated with the DSUB connector in Figure 3 are marked with a dagger (†).

Figure 1 shows a simplified system connection diagram.

Figure 1. NI 9516 Connection Example

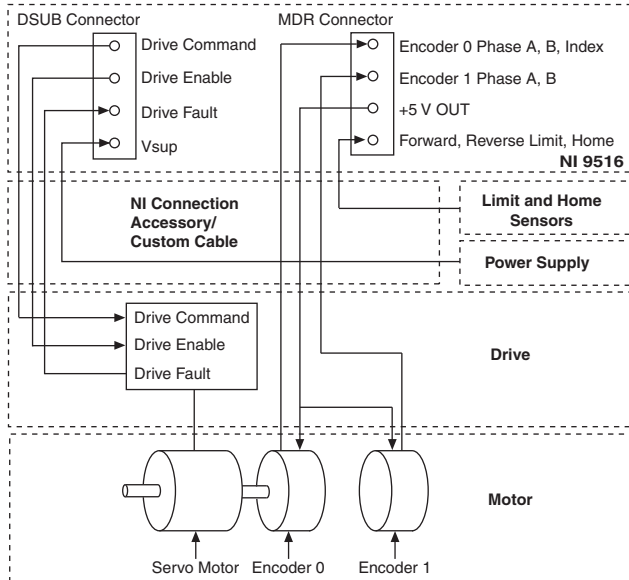


Table 1. NI 9516 DSUB Connector Pin Assignments

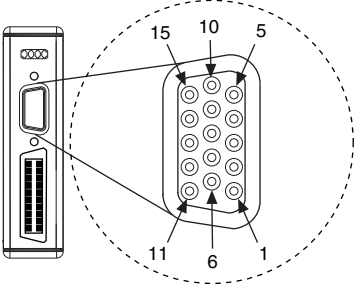
Connector	Pin	Signal
	1	Drive Command COM
	2	Drive Enable
	3	Reserved
	4	Reserved
	5	Reserved
	6	Drive Command
	7	COM
	8	Digital Input 1
	9	Reserved
	10	Reserved
	11	Reserved
	12	Vsup
	13	Reserved
	14	COM
	15	Reserved

Figure 2. NI 9516 MDR Connector Pin Assignments

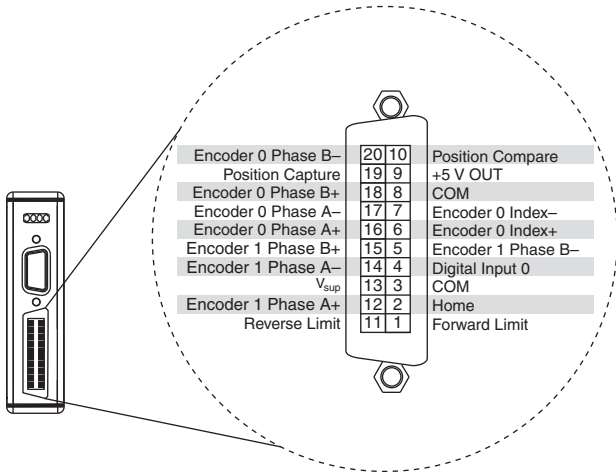








































Figure 3. NI 9516 37-Pin Terminal Block Pin Assignments

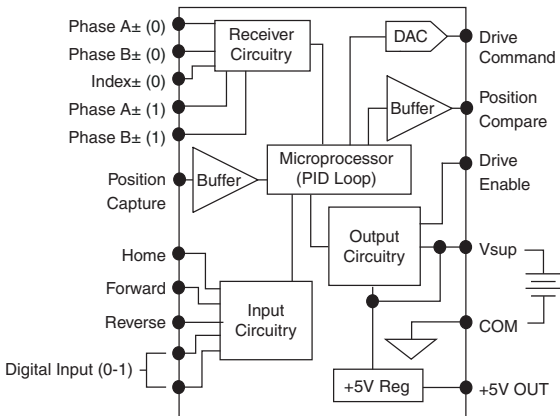
Forward Limit		1		19	Reserved
Home		2		20	Reverse Limit
COM		3		21	Encoder 1 Phase A+
Digital Input 0		4		22	V _{sup}
Encoder 1 Phase B-		5		23	Encoder 1 Phase A-
Encoder 0 Index+		6		24	Encoder 1 Phase B+
Encoder 0 Index-		7		25	Encoder 0 Phase A+
COM		8		26	Encoder 0 Phase A-
+5V OUT		9		27	Encoder 0 Phase B+
Position Compare		10		28	Position Capture
Reserved		11		29	Encoder 0 Phase B-
Drive Command†		12		30	Reserved
Reserved		13		31	Drive Command COM†
V _{sup} †		14		32	COM†
Digital Input 1†		15		33	Drive Enable†
Reserved		16		34	Reserved
COM†		17		35	Reserved
Reserved		18		36	Reserved
Shield		GND		37	Reserved

† Indicates DSUB connector signals.

Signal Connections

Figure 4 shows the NI 9516 block diagram.

Figure 4. NI 9516 Block Diagram



Note This document provides a brief overview of the module signal connections. Refer to the *NI 951x User*

Manual, which you can download from ni.com/manuals, for more information about signal connections.

Drive Command Output

The NI 9516 module provides a ± 10 V analog Drive Command output. Use the Drive Command COM signal instead of COM as a reference for the Drive Command Output. This reference signal helps keep digital noise separate from the analog output.

Encoder Signals

The NI 9516 supports two encoder channels that allow for dual-loop feedback, which enhances system stability and precision and provides backlash compensation. The Encoder 0 channel consists of a Phase A, a Phase B, and an Index input. The Encoder 1 channel consists of a Phase A and a Phase B input.

The NI 9516 supports RS-422 differential and single-ended inputs for Phase A, Phase B, and Index signals, and provides a +5 V output for encoder power. National Instruments strongly recommends you use encoders with differential line driver outputs for optimized noise immunity and improved accuracy in all applications. Figures 5 and 6 show simplified schematic diagrams

of the encoder input circuit connected to differential and single-ended encoder outputs.

Figure 5. Differential Encoder Input Circuit

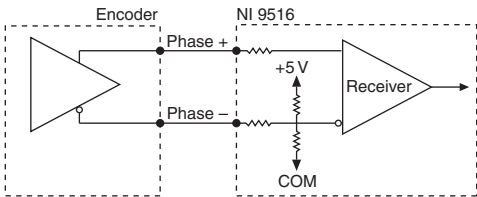
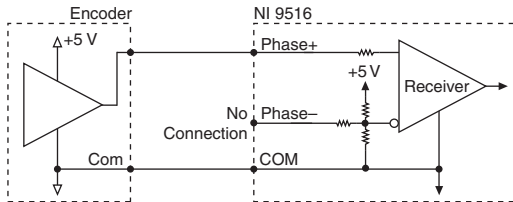


Figure 6. Single-Ended Encoder Input Circuit



Limit and Digital Input Signals

You can configure the Forward Limit, Reverse Limit, and Digital Input <1..2> signals in software for sinking or sourcing output devices and set the active state of the inputs in software to on or off. To use the Drive Fault signal referenced in Figure 1, you can map an available digital input in software. Figure 7 shows an example of wiring the input signals to a sourcing output device.

Figure 7. Limit or Digital Input Circuit Configured for Sinking

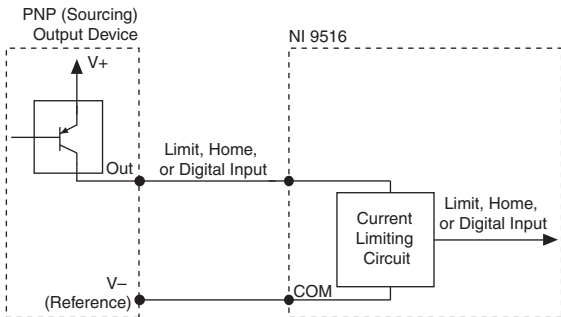
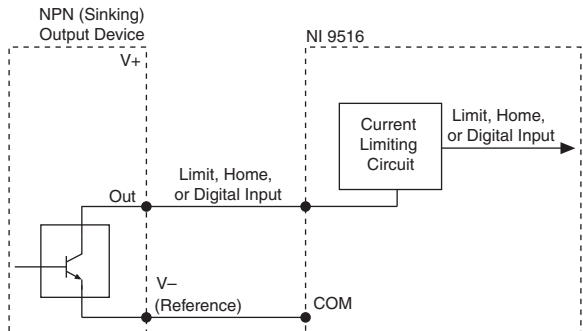


Figure 8 shows an example of wiring the input signals to a sinking output device.

Figure 8. Limit or Digital Input Circuit Configured for Sourcing



Drive Enable

The NI 9516 Drive Enable signal is software configurable for sinking or sourcing output type and the active state is software configurable for on or off.



Caution Do *not* connect the Drive Enable output to a +5 V input circuit when the Drive Enable output is configured for sourcing.

Figure 9 shows an example of wiring the output signals to a sinking input device.

Figure 9. Drive Enable Output Circuit Configured for Sourcing

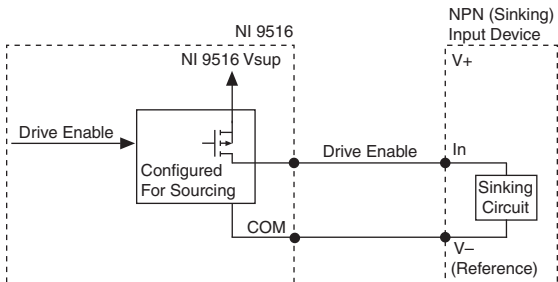
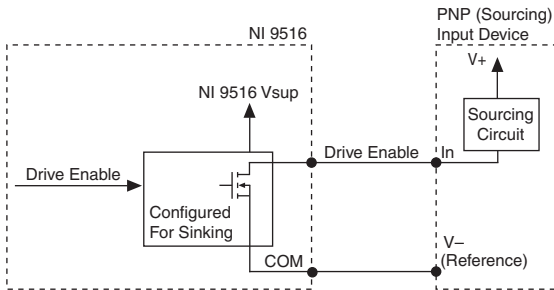


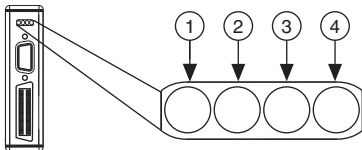
Figure 10 shows an example of wiring the output signals to a sourcing input device.

Figure 10. Drive Enable Output Circuit Configured for Sinking



LED Indicators

The NI 9516 has four LEDs to display status information.



-
- | | | | |
|---|------------------------|---|-----------------------|
| 1 | Axis Status (Green) | 3 | Limit Active (Yellow) |
| 2 | Encoder Active (Green) | 4 | Axis Fault (Red) |
-

Axis Status

The Axis Status LED (green) has three states to display axis status.

- **Off**—The module is in sleep mode or failed to boot correctly. Refer to the *NI SoftMotion Module* book of the *LabVIEW Help* for troubleshooting information.
- **Flashing**—The module booted up correctly and is functional.
- **Lit**—The module is functional and the drive enable output is active.

Encoder Active

The Encoder Active LED (green) has three states for encoder and V_{sup} status.

- **Off**—The required power supply (V_{sup}) is not connected. You must connect a power supply to receive encoder pulses.
- **Flashing**—The power supply (V_{sup}) is connected and the module is receiving encoder pulses.



Note The encoder LED flashes when pulses are received on either Encoder 0 or Encoder 1. The LED flash rate does not correspond to the rate at which the NI 9516 receives encoder pulses.

- **Lit**—The power supply (V_{sup}) is connected but the module is not receiving encoder pulses.

Limit Active

The Limit Active LED (yellow) has two states to display the status of the limits and home input.

- **Off**—The power supply (V_{sup}) is not connected, or both the limits and home input are not active.

- **Lit**—The power supply (V_{sup}) is connected and the forward limit, reverse limit, or home input is active.

Axis Fault

The Axis Fault LED (red) has two states to indicate the presence of a fault in the system. Refer to the *NI SoftMotion Module* book of the *LabVIEW Help* for a list of module faults and troubleshooting information.

- **Off**—No module faults.
- **Lit**—One or more module faults.

Sleep Mode

This module supports a low-power sleep mode. Support for sleep mode at the system level depends on the chassis that the module is plugged into. Refer to the chassis manual for information about support for sleep mode. If the chassis supports sleep mode, refer to the software help for information about enabling sleep mode. Visit ni.com/info and enter `cseriesdoc` for information about C Series documentation.

Typically, when a system is in sleep mode, you cannot communicate with the modules. In sleep mode, the system

consumes minimal power and may dissipate less heat than it does in normal mode. Refer to the *Specifications* section for more information about power consumption and thermal dissipation.

Specifications

The following specifications are typical for the range -40 to 70 °C unless otherwise noted. All voltages are relative to COM unless otherwise noted.

Servo Performance

Module modes of operation	Position loop and torque loop
Control loop rate ¹	20 kHz max (position loop)
Servo control loop modes	PID, PIVff, and Dual-Loop

¹ When using a torque loop, the control loop rate depends on the processor speed and communication bus bandwidth. Refer to the *NI SoftMotion Module* book of the *LabVIEW Help* for more information.

Motion Command Signals

Servo command analog outputs

Voltage range	± 10 V, relative to Drive Command COM
Resolution	16 bits (0.000305 V/LSB), monotonic
Max output current	± 2 mA

Drive enable output

Output type	Software-selectable: sinking or sourcing
Voltage range	0 to 30 V
V _{sup} input	19 to 30 V
Continuous output current (I_0) on each channel	± 100 mA max
Output impedance (R_0)	0.3 Ω max
Output voltage (V_0) sourcing	$V_{sup} - (I_0 R_0)$
Output voltage (V_0) sinking	$I_0 R_0$
Min output pulse width	100 μ s
Active state	Software-selectable: on or off

Motion I/O

Encoder 0 and 1 Phase A/B and Encoder 0 Index inputs

Type RS-422 differential or
single-ended inputs

Digital logic levels, single-ended

Voltage -0.25 to 5.25 V

High, V_{IH} 2.0 V min

Low, V_{IL} 0.8 V max

Digital logic levels, differential (Phase(+)-Phase(-))

Input high range 300 mV to 5 V

Input low range -300 mV to -5 V

Common-mode voltage¹ -7 to 12 V

Input current at 5 V ± 1 mA

Min pulse width²

Differential 100 ns

Single-ended 400 ns

¹ Common-mode voltage is the average of Phase+ and Phase-.

² Assumes the minimum filter setting. Refer to the *NI SoftMotion Module* book of the *LabVIEW Help* for more information about filter options.

Max count rate

Differential 20×10^6 counts/sec

Single-ended 5×10^6 counts/sec

Forward, reverse, and home inputs

Input type Software-selectable: sinking
or sourcing

Limit or home input configured for sinking

Digital logic levels, OFF state

Input voltage ≤ 5 V

Input current ≤ 250 μ A

Digital logic levels, ON state

Input voltage 11 to 30 V

Input current ≥ 2 mA

Limit or home input configured for sourcing

Digital logic levels, OFF state

Input voltage 11 to 30 V

Input current ≤ 1 mA

Digital logic levels, ON state

Input voltage ≤ 5 V

Input current ≥ 2 mA

Min pulse width ¹	50 μ s
Position capture input	
Digital logic levels	
Voltage	-0.25 to 5.25 V
High, VIH	2.0 V min
Low, VIL.....	0.8 V max
Input current	
(0 V \leq Vin \leq 4.5 V)	\pm 2 mA max
Min pulse width ¹	100 ns
Max capture latency	200 ns
Capture accuracy	\pm 1 count
Active edge.....	Software-selectable: rising edge or falling edge
Position compare outputs	
High, VOH	5.25 V max
Sourcing 12 mA	3.7 V min
Sourcing 4 mA	3.9 V min

¹ Assumes the minimum filter setting. Refer to the *NI SoftMotion Module* book of the *LabVIEW Help* for more information about filter options.

Low, VOL

Sinking 12 mA 0.7 V max

Sinking 4 mA 0.5 V max

Compare mode Software-selectable: single
or periodic

Compare action Software-selectable: set,
toggle, or pulse

Max compare rate (periodic) 5 MHz

Pulse width (programmable)

Min 100 ns

Max 1.6 ms

Active state Software-selectable: high or
low

Digital Inputs

Number of inputs 2

Input type Software-selectable: sinking
or sourcing

Digital input configured for sinking

Digital logic levels, OFF state

Input voltage ≤ 5 V

Input current.....	$\leq 250 \mu\text{A}$
Digital logic levels, ON state	
Input voltage	11 to 30 V
Input current.....	$\geq 2 \text{ mA}$
Digital input configured for sourcing	
Digital logic levels, OFF state	
Input voltage	11 to 30 V
Input current.....	$\leq 1 \text{ mA}$
Digital logic levels, ON state	
Input voltage	$\leq 5 \text{ V}$
Input current.....	$\geq 2 \text{ mA}$
Min pulse width ¹	50 μs
MTBF	Contact NI for Bellcore MTBF or MIL-HDBK-217F specifications.

¹ Assumes the minimum filter setting. Refer to the *NI SoftMotion Module* book of the *LabVIEW Help* for more information about filter options.

Power Requirements

Power consumption from chassis

Active mode 950 mW max

Sleep mode 0.4 mW max

Thermal dissipation (at 70 °C)

Active mode 1.5 W max

Sleep mode 0.4 mW max

NI 9516 Input and Output Characteristics

Vsup input 19 to 30 V, 150 mA max

+5 V regulated output..... 5 V \pm 5%, 300 mA max

Physical Characteristics

If you need to clean the module, wipe it with a dry towel.



Note For two-dimensional drawings and three-dimensional models of the C Series module and connectors, visit ni.com/dimensions and search by module number.

Weight..... 155 g (5.5 oz)

Safety

Safety Voltages

Connect only voltages that are within the following limits.

Channel-to-COM 0 to +30 VDC max,
Measurement Category I

Isolation

Channel-to-channel None

Channel-to-earth ground

Continuous 30 VDC,
Measurement Category I

Withstand 500 Vrms, verified by a 5 s
dielectric withstand test

Measurement Category I is for measurements performed on circuits not directly connected to the electrical distribution system referred to as *MAINS* voltage. *MAINS* is a hazardous live electrical supply system that powers equipment. This category is for measurements of voltages from specially protected secondary circuits. Such voltage measurements include signal levels, special equipment, limited-energy parts of equipment, circuits powered by regulated low-voltage sources, and electronics.



Caution Do not connect the NI 9516 to signals or use for measurements within Measurement Categories II, III, or IV.

Hazardous Locations

U.S. (UL)	Class I, Division 2, Groups A, B, C, D, T4; Class I, Zone 2, AEx nA IIC T4
Canada (C-UL)	Class I, Division 2, Groups A, B, C, D, T4; Class I, Zone 2, Ex nA IIC T4
Europe (DEMKO)	Ex nA IIC T4

Safety and Hazardous Location Standards

This product meets the requirements of the following standards of safety for electrical equipment for measurement, control, and laboratory use:

- IEC 61010-1, EN 61010-1
- UL 61010-1, CSA 61010-1
- EN 60079-0:2012, EN 60079-15:2010

- IEC 60079-0: Ed 6, IEC 60079-15; Ed 4
- UL 60079-0; Ed 5, UL 60079-15; Ed 3
- CSA 60079-0:2011, CSA 60079-15:2012



Note For UL and other safety certifications, refer to the product label or the [Online Product Certification](#) section.

Electromagnetic Compatibility

This product meets the requirements of the following EMC standards for electrical equipment for measurement, control, and laboratory use:

- EN 61326-1 (IEC 61326-1): Class A emissions; Industrial immunity
- EN 55011 (CISPR 11): Group 1, Class A emissions
- AS/NZS CISPR 11: Group 1, Class A emissions
- FCC 47 CFR Part 15B: Class A emissions
- ICES-001: Class A emissions



Note For the standards applied to assess the EMC of this product, refer to the [Online Product Certification](#) section.



Note For EMC compliance, operate this device with double-shielded cables.

CE Compliance

This product meets the essential requirements of applicable European directives as follows:

- 2014/35/EU; Low-Voltage Directive (safety)
- 2014/30/EU; Electromagnetic Compatibility Directive (EMC)
- 94/9/EC; Potentially Explosive Atmospheres (ATEX)

Online Product Certification

Refer to the product Declaration of Conformity (DoC) for additional regulatory compliance information. To obtain product certifications and the DoC for this product, visit ni.com/certification, search by module number or product line, and click the appropriate link in the Certification column.

Shock and Vibration

To meet these specifications, you must panel mount the system.

Operating vibration

Random (IEC 60068-2-64)..... 5 g_{rms}, 10 to 500 Hz

Sinusoidal (IEC 60068-2-6) 5 g, 10 to 500 Hz

Operating shock
(IEC 60068-2-27)..... 30 g, 11 ms half sine,
50 g, 3 ms half sine,
18 shocks at 6 orientations

Environmental

Refer to the manual for the chassis you are using for more information about meeting these specifications.

Operating temperature
(IEC 60068-2-1, IEC 60068-2-2) -40 to 70 °C

Storage temperature
(IEC 60068-2-1, IEC 60068-2-2) -40 to 85 °C

Ingress protection..... IP 40

Operating humidity
(IEC 60068-2-56)..... 10 to 90% RH,
noncondensing

Storage humidity
(IEC 60068-2-56)..... 5 to 95% RH,
noncondensing

Pollution Degree (IEC 60664)..... 2

Maximum altitude..... 5,000 m

Indoor use only.

Environmental Management

NI is committed to designing and manufacturing products in an environmentally responsible manner. NI recognizes that eliminating certain hazardous substances from our products is beneficial to the environment and to NI customers.

For additional environmental information, refer to the *Minimize Our Environmental Impact* web page at ni.com/environment. This page contains the environmental regulations and directives with which NI complies, as well as other environmental information not included in this document.

Waste Electrical and Electronic Equipment (WEEE)



EU Customers At the end of the product life cycle, all products *must* be sent to a WEEE recycling center. For more information about WEEE recycling centers, National Instruments WEEE initiatives, and compliance with WEEE Directive 2002/96/EC on Waste and Electronic Equipment, visit ni.com/environment/weee.

电子信息产品污染控制管理办法（中国 RoHS）



中国客户 National Instruments 符合中国电子信息产品中限制使用某些有害物质指令 (RoHS)。关于 National Instruments 中国 RoHS 合规性信息，请登录 ni.com/environment/rohs_china。(For information about China RoHS compliance, go to ni.com/environment/rohs_china.)

Worldwide Support and Services

The NI website is your complete resource for technical support. At ni.com/support you have access to everything from troubleshooting and application development self-help resources to email and phone assistance from NI Application Engineers.

Visit ni.com/services for NI Factory Installation Services, repairs, extended warranty, and other services.

Visit ni.com/register to register your NI product. Product registration facilitates technical support and ensures that you receive important information updates from NI.

A Declaration of Conformity (DoC) is our claim of compliance with the Council of the European Communities using the manufacturer's

declaration of conformity. This system affords the user protection for electromagnetic compatibility (EMC) and product safety. You can obtain the DoC for your product by visiting ni.com/certification. If your product supports calibration, you can obtain the calibration certificate for your product at ni.com/calibration.

NI corporate headquarters is located at 11500 North Mopac Expressway, Austin, Texas, 78759-3504. NI also has offices located around the world. For telephone support in the United States, create your service request at ni.com/support or dial 1 866 ASK MYNI (275 6964). For telephone support outside the United States, visit the Worldwide Offices section of ni.com/niglobal to access the branch office websites, which provide up-to-date contact information, support phone numbers, email addresses, and current events.

Refer to the *NI Trademarks and Logo Guidelines* at ni.com/trademarks for more information on National Instruments trademarks. Other product and company names mentioned herein are trademarks or trade names of their respective companies. For patents covering National Instruments products/technology, refer to the appropriate location: **Help»Patents** in your software, the `patents.txt` file on your media, or the *National Instruments Patent Notice* at ni.com/patents. You can find information about end-user license agreements (EULAs) and third-party legal notices in the readme file for your NI product. Refer to the *Export Compliance Information* at ni.com/legal/export-compliance for the National Instruments global trade compliance policy and how to obtain relevant HTS codes, ECCNs, and other import/export data. NI MAKES NO EXPRESS OR IMPLIED WARRANTIES AS TO THE ACCURACY OF THE INFORMATION CONTAINED HEREIN AND SHALL NOT BE LIABLE FOR ANY ERRORS. U.S. Government Customers: The data contained in this manual was developed at private expense and is subject to the applicable limited rights and restricted data rights as set forth in FAR 52.227-14, DFAR 252.227-7014, and DFAR 252.227-7015.

© 2009–2015 National Instruments. All rights reserved.