

COMPREHENSIVE SERVICES

We offer competitive repair and calibration services, as well as easily accessible documentation and free downloadable resources.

SELL YOUR SURPLUS

We buy new, used, decommissioned, and surplus parts from every NI series. We work out the best solution to suit your individual needs.

 Sell For Cash  Get Credit  Receive a Trade-In Deal

OBSOLETE NI HARDWARE IN STOCK & READY TO SHIP

We stock **New**, **New Surplus**, **Refurbished**, and **Reconditioned** NI Hardware.



Bridging the gap between the manufacturer and your legacy test system.

 1-800-915-6216

 www.apexwaves.com

 sales@apexwaves.com

All trademarks, brands, and brand names are the property of their respective owners.

Request a Quote

 **CLICK HERE**

NI-9860

GETTING STARTED GUIDE

NI 9860

NI-XNET Hardware Selectable Interface

Français

Deutsch

日本語

한국어

简体中文

ni.com/manuals

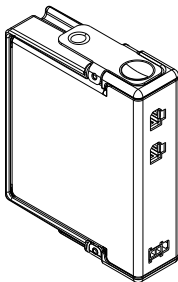

This document explains how to connect to the NI 9860.



Note Before you begin, complete the software and hardware installation procedures in your chassis documentation.



Note The guidelines in this document are specific to the NI 9860. The other components in the system might not meet the same safety ratings. Refer to the documentation for each component in the system to determine the safety and EMC ratings for the entire system.

Safety Guidelines

Operate the NI 9860 only as described in this document.



Hot Surface This icon denotes that the component may be hot. Touching this component may result in bodily injury.



Caution Do not operate the NI 9860 in a manner not specified in this document. Product misuse can result in a hazard. You can compromise the safety protection

built into the product if the product is damaged in any way. If the product is damaged, return it to NI for repair.

Safety Guidelines for Hazardous Locations

The NI 9860 is suitable for use in Class I, Division 2, Groups A, B, C, D, T4 hazardous locations; Class I, Zone 2, AEx nA IIC T4 and Ex nA IIC T4 hazardous locations; and nonhazardous locations only. Follow these guidelines if you are installing the NI 9860 in a potentially explosive environment. Not following these guidelines may result in serious injury or death.



Caution Do not disconnect I/O-side wires or connectors unless power has been switched off or the area is known to be nonhazardous.



Caution Do not remove modules unless power has been switched off or the area is known to be nonhazardous.



Caution Substitution of components may impair suitability for Class I, Division 2.



Caution For Division 2 and Zone 2 applications, install the system in an enclosure rated to at least IP54 as defined by IEC/EN 60079-15.

Special Conditions for Hazardous Locations Use in Europe and Internationally

The NI 9860 has been evaluated as Ex nA IIC T4 Gc equipment under DEMKO Certificate No. 12 ATEX 1202658X and is IECEx 14.0089X certified. Each NI 9860 is marked  II 3G and is suitable for use in Zone 2 hazardous locations, in ambient temperatures of $-40\text{ }^{\circ}\text{C} \leq T_a \leq 70\text{ }^{\circ}\text{C}$. If you are using the NI 9860 in Gas Group IIC hazardous locations, you must use the device in an NI chassis that has been evaluated as Ex nC IIC T4, Ex IIC T4, Ex nA IIC T4, or Ex nL IIC T4 equipment.



Caution You must make sure that transient disturbances do not exceed 140% of the rated voltage.



Caution The system shall only be used in an area of not more than Pollution Degree 2, as defined in IEC 60664-1.



Caution The system shall be mounted in an ATEX/IECEx-certified enclosure with a minimum

ingress protection rating of at least IP54 as defined in IEC/EN 60079-15.



Caution The enclosure must have a door or cover accessible only by the use of a tool.

Wiring the NI 9860

The NI 9860 has two ports for connecting to NI-XNET CAN/LIN Transceiver Cables (required to connect to the CAN/LIN bus) and a two-position connector for use with an external power supply.

For more information about transceiver cables, refer to the [NI-XNET CAN/LIN Transceiver Cables](#) page on [ni.com](#).

The NI 9860 requires an external power supply of +9 to +30 V to power the transceiver cables. Supply power to the NI 9860 V_{SUP} connector on the module front panel using the supplied power cable. The exposed lead wires at the end of the power cable are routed as follows: black wire—COM, red wire— V_{SUP} . The power cable lead wires may be daisy-chained to the controller power port when the controller supply voltage is in the appropriate range.



Note Power on V_{SUP} is required for transceiver cable operation.



Note When using more than four transceiver cables with your CompactRIO chassis, refer to the [NI-XNET CAN/LIN Transceiver Cables](#) page on [ni.com](#) for mounting guidelines to limit the thermal impact to your CompactRIO system.

The following figure shows the NI 9860 with Port 1 connected to an NI-XNET CAN HS/FD Transceiver Cable and the two-position connector connected to the power cable. The breaks in the cables represent additional cable length.

Figure 1. NI 9860 with Power and Transceiver Cables Attached

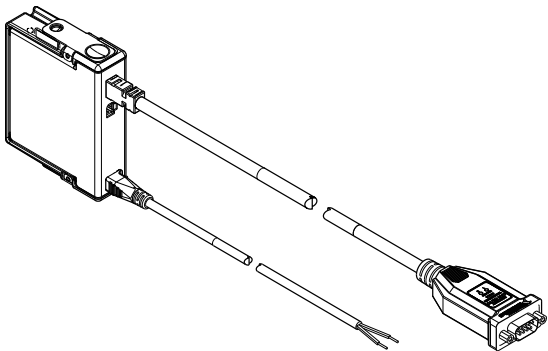

NI 9860 Hardware Overview

The NI 9860 is a two-port C-Series module based on the XNET architecture. Users can choose the physical bus protocol by plugging in the corresponding transceiver cable. The NI 9860

supports hot-swapping of transceiver cables and can detect and identify transceiver cable types.

For more information about transceiver cables, refer to the [NI-XNET CAN/LIN Transceiver Cables](#) page on [ni.com](#).

Figure 2. NI 9860 Hardware Overview

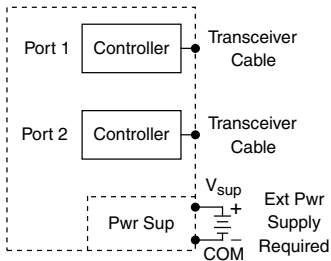

Inserting and Removing the NI-XNET Transceiver Cable

The NI-XNET Transceiver Cable connects to a host device with an active latching connector. To connect the NI-XNET Transceiver Cable to a host device, push the connector assembly into the host receptacle until the internal latch snaps into position. The latch emits an audible click when engaged. To remove the NI-XNET Transceiver Cable, push the lock ejector forward to disengage the latch and simultaneously pull the NI-XNET Transceiver Cable, as shown in the following figure.

Figure 3. Inserting and Removing the NI-XNET Transceiver Cable

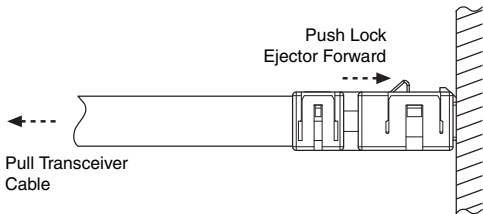

Inserting and Removing the Power Cable

The NI 9860 connects to the provided power cable with an active latching connector. To connect the power cable, push the end of the power cable into the two-position connector until the internal latch snaps into position. The latch emits an audible click when engaged.

To remove the power cable, push the lock ejector down to disengage the latch and simultaneously pull the power cable away from the module, as shown in the following figure.

Figure 4. Removing the NI 9860 Power Cable

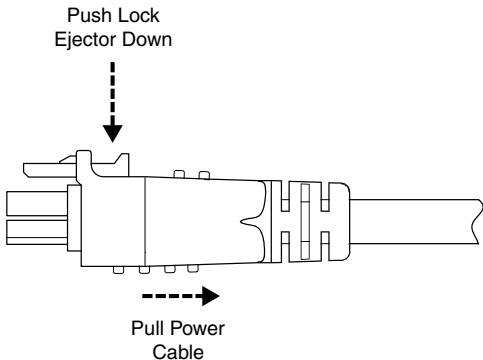

NI 9860 Specifications

The following specifications are typical for the range -40 °C to 70 °C unless otherwise noted.

NI-XNET Host Port

Connector type.....	NI-XNET hardware selectable interface port
Port supported transceiver..... cable types	NI-XNET transceiver cables (CAN/LIN)



Note For more information about transceiver cables, refer to the transceiver cable operating instructions.

Power Requirements

Power consumption from chassis

Active mode.....	1 W max
Sleep mode.....	5 mW max

External Power Supply¹ (V_{SUP})

Voltage input range.....	9 to 30 VDC (measured at the NI 9860 power connector)
Power consumption.....	1.5 W max (active mode)



Caution Do not connect V_{SUP} to a DC mains supply or to any supply requiring a connecting cable longer than 3 m (10 ft). A DC mains supply is a local DC electricity supply network in the infrastructure of a site or building.

Total thermal dissipation.....	1.2 W max (active mode) on module
--------------------------------	-----------------------------------

Physical Characteristics

To clean the module, wipe it with a dry towel.

Weight.....	Approx. 144 g (5.0 oz)
-------------	------------------------

¹ Required to power NI-XNET Transceiver Cables.

Safety Voltages

Connect only voltages that are within the following limits:

V_{SUP} to COM.....	30 VDC max, Measurement Category I
Chassis ground to COM.....	30 VDC max, Measurement Category I

Measurement Category I is for measurements performed on circuits not directly connected to the electrical distribution system referred to as *MAINS* voltage. *MAINS* is a hazardous live electrical supply system that powers equipment. This category is for measurements of voltages from specially protected secondary circuits. Such voltage measurements include signal levels, special equipment, limited-energy parts of equipment, circuits powered by regulated low-voltage sources, and electronics.



Caution Do not connect the system to signals or use for measurements within Measurement Categories II, III, or IV.



Note Measurement Categories CAT I and CAT O are equivalent. These test and measurement circuits are not intended for direct connection to the MAINS building installations of Measurement Categories CAT II, CAT III, or CAT IV.

Safety and Hazardous Locations Standards

This product is designed to meet the requirements of the following electrical equipment safety standards for measurement, control, and laboratory use:

- IEC 61010-1, EN 61010-1
- UL 61010-1, CSA 61010-1
- EN 60079-0:2012, EN 60079-15:2010
- IEC 60079-0: Ed 6, IEC 60079-15; Ed 4
- UL 60079-0; Ed 5, UL 60079-15; Ed 3
- CSA 60079-0:2011, CSA 60079-15:2012



Note For UL and other safety certifications, refer to the product label or the [Online Product Certification](#) section.

Hazardous Locations

U.S. (UL).....	Class I, Division 2, Groups A, B, C, D, T4; Class I, Zone 2, AEx nA IIC T4
Canada (C-UL).....	Class I, Division 2, Groups A, B, C, D, T4; Class I, Zone 2, Ex nA IIC T4
Europe (DEMKO).....	Ex nA IIC T4 Gc

Environmental

Refer to the installation instructions for the chassis you are using for more information about meeting these specifications.

Operating temperature.....-40 °C to 70 °C
(IEC 60068-2-1, IEC 60068-2-2)

Storage temperature.....-40 °C to 85 °C
(IEC 60068-2-1, IEC 60068-2-2)

Ingress protection

NI 9860.....IP 30

NI 9860 with power.....IP 40
and transceiver
cables attached

Operating humidity.....10% RH to 90% RH,
(IEC 60068-2-56) noncondensing

Storage humidity.....5% RH to 95% RH,
(IEC 60068-2-56) noncondensing

Pollution degree (IEC.....2
60664)

Maximum altitude.....5,000 m

Indoor use only.

Shock and Vibration

To meet these specifications, you must panel mount the system.

Operating vibration

Random (IEC.....5 g_{rms}, 10 Hz to 500 Hz
60068-2-64)

Sinusoidal (IEC.....5 g, 10 Hz to 500 Hz
60068-2-6)

Operating shock (IEC.....30 g, 11 ms half sine; 50 g,
60068-2-27) 3 ms half sine;
18 shocks at 6 orientations

Electromagnetic Compatibility

This product meets the requirements of the following EMC standards for electrical equipment for measurement, control, and laboratory use:

- EN 61326 (IEC 61326): Class A emissions; Basic immunity
- EN 55011 (CISPR 11): Group 1, Class A emissions
- AS/NZS CISPR 11: Group 1, Class A emissions

- FCC 47 CFR Part 15B: Class A emissions
- ICES-001: Class A emissions



Note For the standards applied to assess the EMC of this product, refer to the *Online Product Certification* section.



Note For EMC compliance, operate this product according to the documentation.

CE Compliance

This product meets the essential requirements of applicable European Directives, as follows:

- 2014/35/EU; Low-Voltage Directive (safety)
- 2014/30/EU; Electromagnetic Compatibility Directive (EMC)
- 94/9/EC; Potentially Explosive Atmospheres (ATEX)

Online Product Certification

Refer to the product Declaration of Conformity (DoC) for additional regulatory compliance information. To obtain product certifications and the DoC for this product, visit ni.com/

certification, search by model number or product line, and click the appropriate link in the Certification column.

Environmental Management

NI is committed to designing and manufacturing products in an environmentally responsible manner. NI recognizes that eliminating certain hazardous substances from our products is beneficial to the environment and to NI customers.

For additional environmental information, refer to the *Minimize Our Environmental Impact* web page at ni.com/environment. This page contains the environmental regulations and directives with which NI complies, as well as other environmental information not included in this document.

Waste Electrical and Electronic Equipment (WEEE)



EU Customers At the end of the product life cycle, all NI products must be disposed of according to local laws and regulations. For more information about how to recycle NI products in your region, visit ni.com/environment/weee.

电子信息产品污染控制管理办法（中国 RoHS）



中国客户 National Instruments 符合中国电子信息产品中限制使用某些有害物质指令 (RoHS)。关于 National Instruments 中国 RoHS 合规性信息，请登录 ni.com/environment/rohs_china。(For information about China RoHS compliance, go to ni.com/environment/rohs_china.)

Worldwide Support and Services

The National Instruments website is your complete resource for technical support. At ni.com/support, you have access to everything from troubleshooting and application development self-help resources to email and phone assistance from NI Application Engineers.

Visit ni.com/services for NI Factory Installation Services, repairs, extended warranty, and other services.

Visit ni.com/register to register your National Instruments product. Product registration facilitates technical support and ensures that you receive important information updates from NI.

A Declaration of Conformity (DoC) is our claim of compliance with the Council of the European Communities using the manufacturer's declaration of conformity. This system affords the user protection for electromagnetic compatibility (EMC) and product safety. You can obtain the DoC for your product by visiting ni.com/certification. If your product supports calibration, you can obtain the calibration certificate for your product at ni.com/calibration.

National Instruments corporate headquarters is located at 11500 North Mopac Expressway, Austin, Texas, 78759-3504. National Instruments also has offices located around the world. For telephone support in the United States, create your service request at ni.com/support or dial 1 866 ASK MYNI (275 6964). For telephone support outside the United States, visit the *Worldwide Offices* section of ni.com/niglobal to access the branch office websites, which provide up-to-date contact information, support phone numbers, email addresses, and current events.

Refer to the *NI Trademarks and Logo Guidelines* at ni.com/trademarks for information on National Instruments trademarks. Other product and company names mentioned herein are trademarks or trade names of their respective companies. For patents covering National Instruments products/technology, refer to the appropriate location: **Help»Patents** in your software, the `patents.txt` file on your media, or the *National Instruments Patent Notice* at ni.com/patents. You can find information about end-user license agreements (EULAs) and third-party legal notices in the readme file for your NI product. Refer to the *Export Compliance Information* at ni.com/legal/export-compliance for the National Instruments global trade compliance policy and how to obtain relevant HTS codes, ECCNs, and other import/export data. NI MAKES NO EXPRESS OR IMPLIED WARRANTIES AS TO THE ACCURACY OF THE INFORMATION CONTAINED HEREIN AND SHALL NOT BE LIABLE FOR ANY ERRORS. U.S. Government Customers: The data contained in this manual was developed at private expense and is subject to the applicable limited rights and restricted data rights as set forth in FAR 52.227-14, DFAR 252.227-7014, and DFAR 252.227-7015.

© 2015 National Instruments. All rights reserved.

374535A-01 Mar15