

## COMPREHENSIVE SERVICES

We offer competitive repair and calibration services, as well as easily accessible documentation and free downloadable resources.

## SELL YOUR SURPLUS

We buy new, used, decommissioned, and surplus parts from every NI series. We work out the best solution to suit your individual needs.

 Sell For Cash    Get Credit    Receive a Trade-In Deal

## OBSOLETE NI HARDWARE IN STOCK & READY TO SHIP

We stock **New**, **New Surplus**, **Refurbished**, and **Reconditioned** NI Hardware.



*Bridging the gap between the manufacturer and your legacy test system.*

 1-800-915-6216

 [www.apexwaves.com](http://www.apexwaves.com)

 [sales@apexwaves.com](mailto:sales@apexwaves.com)

*All trademarks, brands, and brand names are the property of their respective owners.*

**Request a Quote**

 **CLICK HERE**

**PC-TIO-10**

## CB-50 Connector Block

This guide describes how to connect your data acquisition board and the CB-50 I/O connector block to your computer.

### Introduction

With the CB-50 I/O connector block, you can easily connect analog/digital signals to the National Instruments data acquisition boards. You can use the CB-50 with the following boards:

<b>PC/XT, PC AT</b>	<b>PS/2</b>	<b>Macintosh</b>
AT-MIO-16	MC-MIO-16	NB-MIO-16
AT-MIO-16F-5	MC-DIO-32F	NB-MIO-16X
AT-MIO-16X	MC-DIO-24	NB-DIO-32F
AT-AO-6		NB-DIO-24
AT-AO-10		NB-AO-6
AT-DIO-32F		NB-TIO-10
AT-DIO-24		Lab-NB
Lab-PC		Lab-SE
Lab-PC+		
PC-LPM-16		
PC-DIO-24		
PC-TIO-10		

The CB-50 consists of a 0.5 m or 1.0 m ribbon cable and a connector block with 50 screw terminals. Connector pinout information is in the user manual for each data acquisition board. At each end, the cable has a keyed connector with a centered tab that you must align with the slot on the mating header on the connector block or board.

## What Your Kit Should Contain

The CB-50 I/O connector block kit is available in three versions, depending on your requirements:

- CB-50 with 0.5 m cable assembly
- CB-50 with 1 m cable assembly
- CB-50 without cable assembly

In addition, each version of the kit contains the following components:

- Interface assembly
  - Connector block, ejector ears, and flush-mount and rack-mount brackets
- Screwdriver
- *CB-50 I/O Connector Block Installation Guide*

If your kit is missing any of the components or if you received the wrong version, contact National Instruments.

## Installation

**Warning:** *Although the connectors are keyed, it is possible to force the connectors into the header the wrong way. You must be absolutely certain that the connectors are properly aligned. Failure to do so could cause signals to be connected to the wrong pins, which could damage the data acquisition board and the computer. NATIONAL INSTRUMENTS IS NOT LIABLE FOR DAMAGE RESULTING FROM SUCH CONNECTIONS.*

1. Plug either end of the ribbon cable into the 50-pin rear panel connector on the board. Align the tabs and arrows as shown in Figure 1.

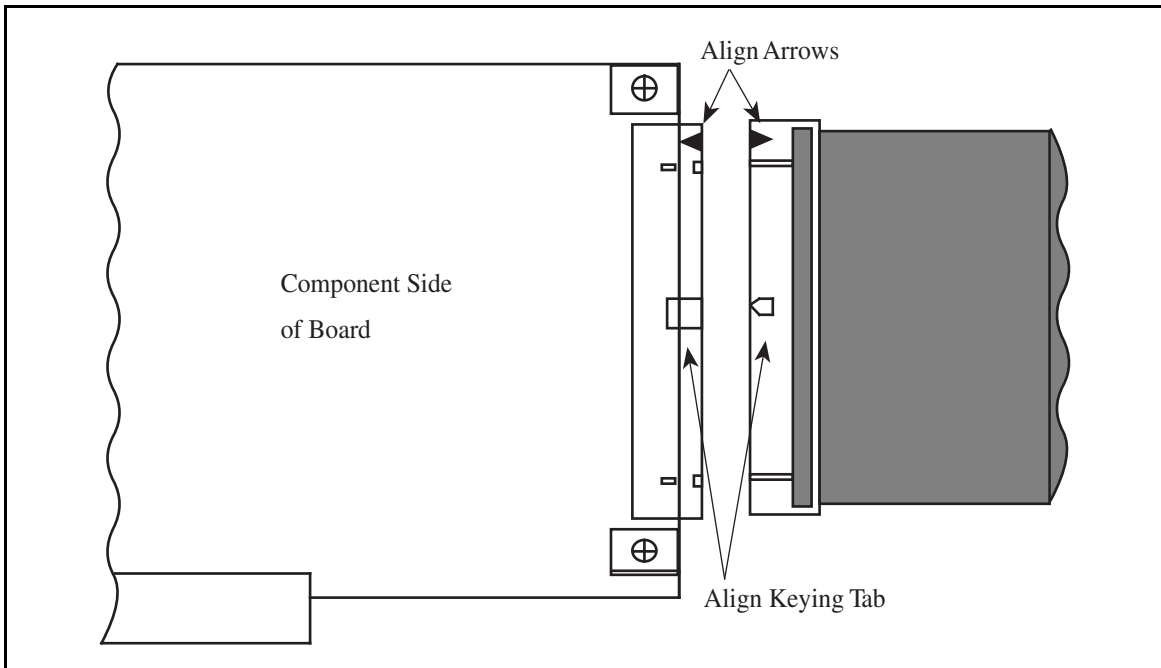

Figure 1. Connecting the 50-Pin Connector to Your Data Acquisition Board

2. Firmly push in the connector for proper contact.
3. Insert the ejector ears into the connector block as shown in Figure 2.

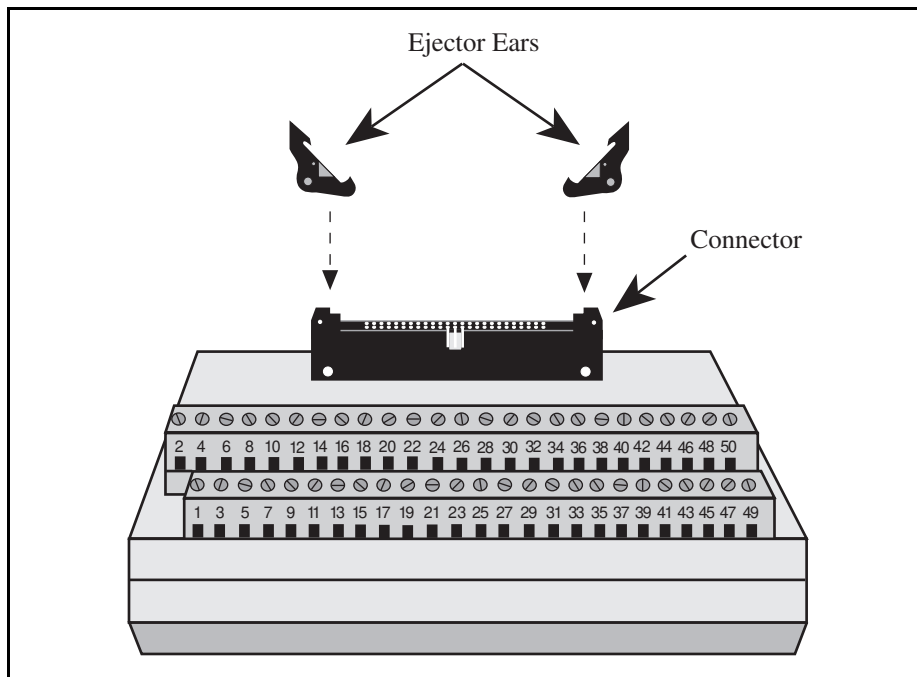

Figure 2. Inserting the Ejector Ears into the Connector Block

4. If you plan to mount your connector block for stability, choose one of the following procedures for mounting. If you do not want to mount your connector blocks, proceed to step 5.
- For flush mounting, insert the flush-mount brackets into the connector block base as shown in Figure 3.

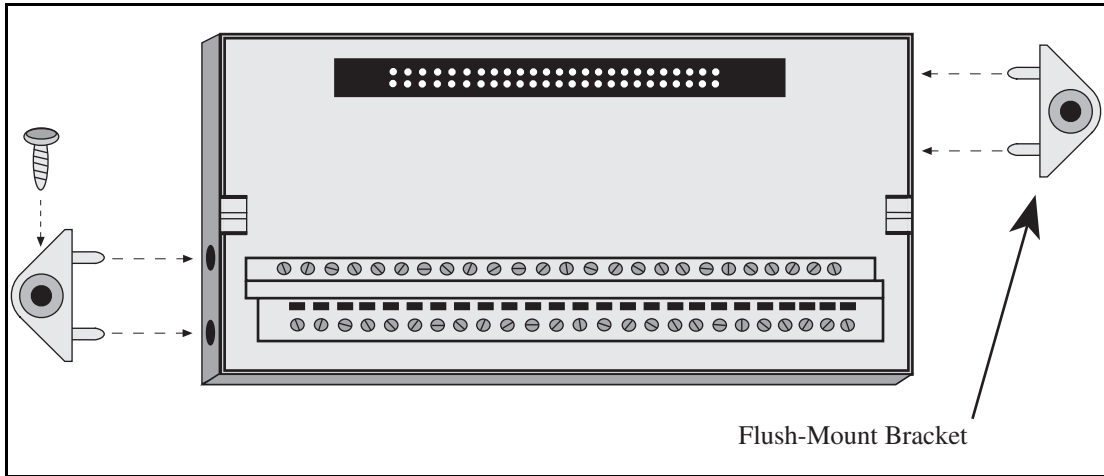

Figure 3. Inserting the Flush-Mount Brackets

Place the connector block where you want to mount it and screw it into place.

- For rail mounting, pry off the right and left ends of the connector block with a screwdriver as shown in Figure 4.

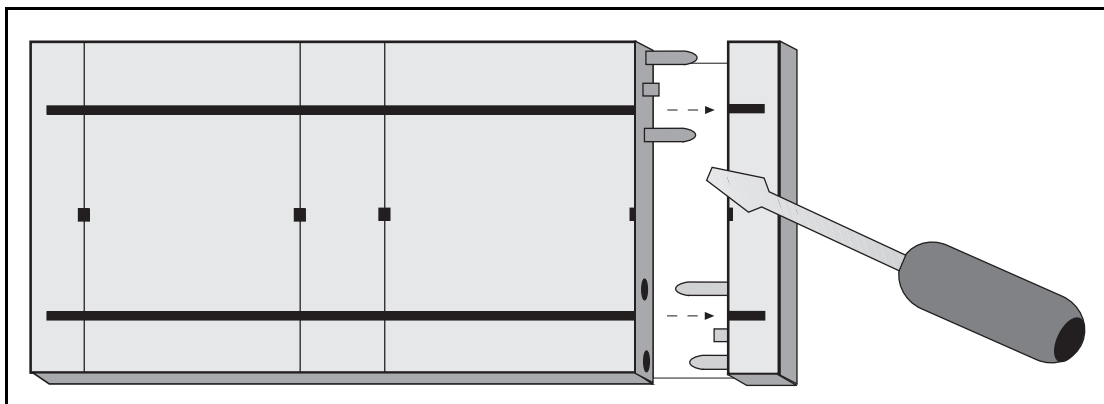

Figure 4. Removing the Connector Block Ends

Insert the rail-mount bracket into the slots on the bottom of the connector block as shown in Figure 5.

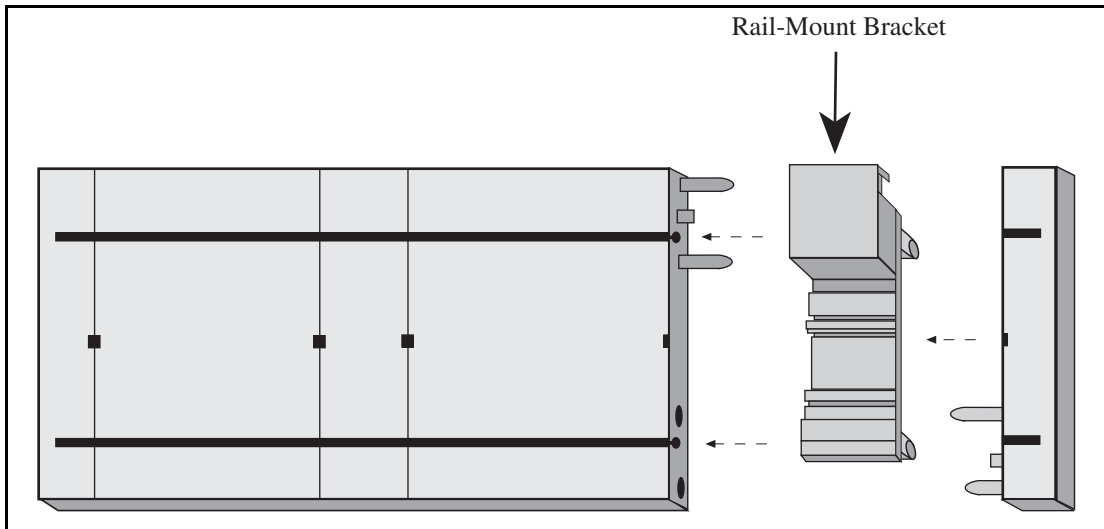

Figure 5. Inserting the Rail-Mount Bracket

Replace the end of the connector block and push very firmly until it snaps into place. Repeat for the other side, making sure that both rail-mount brackets are facing the same direction.

Slide the rail-mount brackets of the connector block onto your rails.

5. Plug the free end of the ribbon cable into the connector block. Align the tabs and arrows as shown in Figure 6.

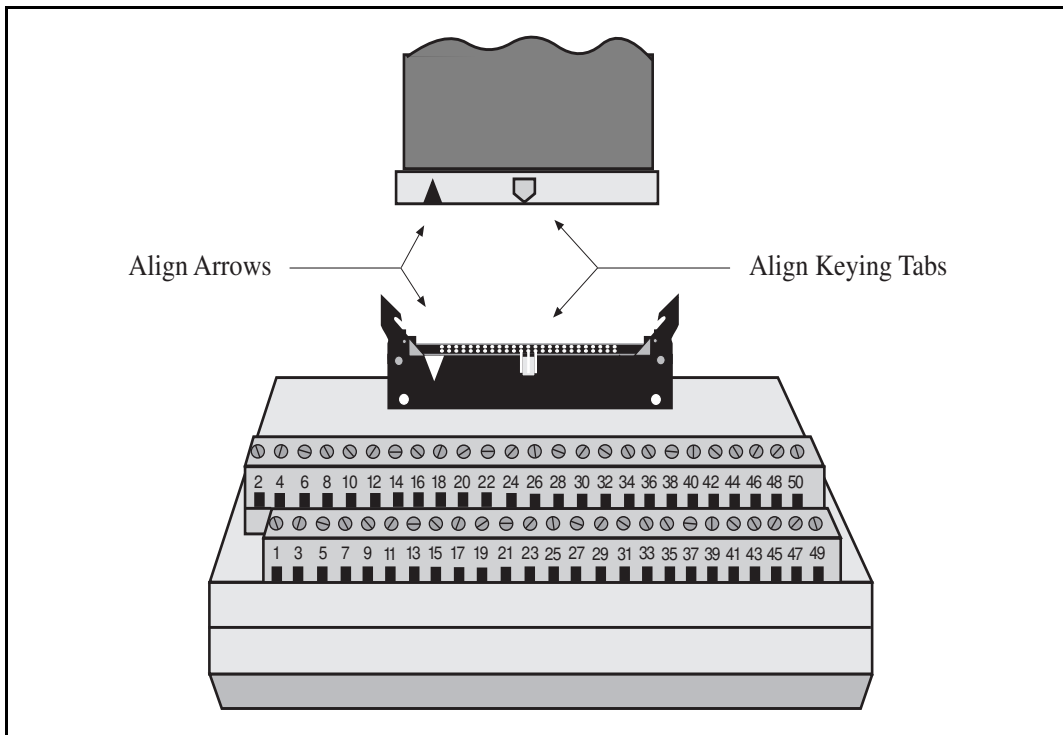

Figure 6. Cable Connections to the CB-50

6. Firmly push in the connector until the ejector ears on the block header connector snap into position.

The numbers on the connector block correspond to the pin numbers of the rear panel I/O connector on the board.

## **Removal**

1. Press down on the ejector ears of the connector block. The connector will pop out.
2. At the other end, grasp the ribbon cable near the connector end and pull it away from the board with a rocking motion.