

COMPREHENSIVE SERVICES

We offer competitive repair and calibration services, as well as easily accessible documentation and free downloadable resources.

SELL YOUR SURPLUS

We buy new, used, decommissioned, and surplus parts from every NI series. We work out the best solution to suit your individual needs.

 Sell For Cash  Get Credit  Receive a Trade-In Deal

OBSOLETE NI HARDWARE IN STOCK & READY TO SHIP

We stock **New**, **New Surplus**, **Refurbished**, and **Reconditioned** NI Hardware.



Bridging the gap between the manufacturer and your legacy test system.

 1-800-915-6216

 www.apexwaves.com

 sales@apexwaves.com

All trademarks, brands, and brand names are the property of their respective owners.

Request a Quote

 **CLICK HERE**

PCI-4351

TC-2190 ADAPTER WITH THERMOCOUPLE MINICONNECTORS INSTALLATION GUIDE

This installation guide describes how to install and connect thermocouples and digital I/O signals to the TC-2190 adapter with thermocouple miniconnectors to use with the NI USB-4350, NI PXI-4351, and NI PCI-4351 data acquisition (DAQ) devices.

Introduction

The TC-2190 adapter consists of a shielded box with 14 miniconnectors that you can use to connect the thermocouples to the NI 435X for USB, PXI, and PCI. This adapter has two 68-pin connectors—one on the front and one on the rear. You can use either of the two connectors to connect the TC-2190 to the NI 435X using an SH6868 shielded cable (recommended) or an R6868 ribbon cable. You can also access the eight digital I/O lines and the digital ground of the NI 435X using the spring terminal blocks.

This adapter is designed specifically for ease of use with thermocouples. It features isothermal construction to minimize the temperature gradients across the thermocouple junctions and a high-accuracy thermistor cold-junction temperature sensor.

The TC-2190 connects to all the digital I/O lines on the NI 435X and all but two analog input channels (CH)—CH0 is dedicated to the cold-junction sensor and CH1 is dedicated to auto-zeroing circuitry. Refer to the *NI 435X User Manual* for further details on the cold-junction sensor and auto-zeroing circuitry.

Conventions

The following conventions are used in this guide:

- » The » symbol leads you through nested menu items and dialog box options to a final action. The sequence **File»Page Setup»Options** directs you to pull down the **File** menu, select the **Page Setup** item, and select **Options** from the last dialog box.

National Instruments™, NI™, ni.com™, and NI-DAQ™ are trademarks of National Instruments Corporation. Product and company names mentioned herein are trademarks or trade names of their respective companies. For patents covering National Instruments products, refer to the appropriate location: **Help»Patents** in your software, the `patents.txt` file on your CD, or `ni.com/patents`.

October 2002
321674C-01



This icon denotes a note, which alerts you to important information.



This icon denotes a caution, which advises you of precautions to take to avoid injury, data loss, or a system crash. When this symbol is marked on the product, refer to the *Read Me First: Safety and Radio-Frequency Interference* document, shipped with the product, for precautions to take.

bold

Bold text denotes items that you must select or click in the software, such as menu items and dialog box options. Bold text also denotes parameter names.

italic

Italic text denotes variables, emphasis, a cross reference, or an introduction to a key concept. This font also denotes text that is a placeholder for a word or value that you must supply.

monospace

Text in this font denotes text or characters that you should enter from the keyboard, sections of code, programming examples, and syntax examples. This font is also used for the proper names of disk drives, paths, directories, programs, subprograms, subroutines, device names, functions, operations, variables, filenames and extensions, and code excerpts.

NI 435X

Refers to all devices in the National Instruments 4350 and 4351 families.

What You Need to Get Started

You need the following items to set up and use the TC-2190:

- TC-2190 adapter with thermocouple miniconnectors
- TC-2190 Adapter with Thermocouple Miniconnectors Installation Guide*
- Read Me First: Safety and Radio-Frequency Interference*
- NI PCI-4351, NI PXI-4351, or NI USB-4350 and documentation
- One of the following cable assemblies:
 - SH6868 shielded cable (recommended)
 - R6868 ribbon cable
- 1/8 in. flathead screwdriver
- Number 1 Phillips screwdriver
- Wire cutters

- Wire insulation strippers
- Four adhesive rubber feet

Configuring the Shield Ground Jumpers



Caution Refer to the *Read Me First: Safety and Radio-Frequency Interference* document before removing equipment covers or connecting/disconnecting any signal wires.

Jumper W1, located inside the TC-2190 on the bottom of the board, connects the shield of the 68-pin connectors and the TC-2190 metal case to NI 435X ground through a 100 Ω resistor (default setting) or directly to NI 435X ground, or keeps the metal case and NI 435X ground separate.

Table 1 shows the configuration options for jumper W1.



Note Use the default setting for jumper W1 unless you notice degraded noise performance.

Table 1. TC-2190 Jumper Configuration Options

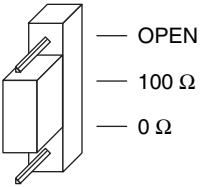
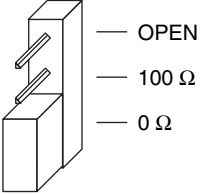
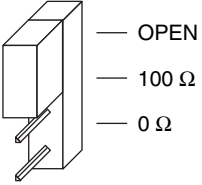
Jumper W1 Configuration	Description	When to Use This Configuration
	<p>100 Ω (factory default)—This setting connects the TC-2190 metal chassis to NI 435X ground through a 100 Ω resistor, while keeping any potential ground loop current very small.</p>	<p>Use this setting when you are using the SH6868 cable, and:</p> <ul style="list-style-type: none"> • You have not rack-mounted the TC-2190, or • You have mounted the TC-2190 on a rack, but are unsure whether the rack and the TC-2190 are grounded.
	<p>0 Ω—This setting connects the TC-2190 metal chassis to NI 435X ground.</p>	<p>Use this setting when you are using the R6868 cable, and:</p> <ul style="list-style-type: none"> • You have not rack-mounted the TC-2190, or • You have mounted the TC-2190 on a rack and are sure that the rack and the TC-2190 are not grounded.
	<p>Open—This setting disconnects the TC-2190 metal chassis from NI 435X ground.</p>	<p>Use this setting when you are using either the SH6868 cable or the R6868 cable, and:</p> <ul style="list-style-type: none"> • You have mounted the TC-2190 on a rack, and • You are sure that the rack and the TC-2190 are grounded.

If you need to change jumper W1, refer to Figure 1 as you complete the following steps:

1. Using the Number 1 Phillips screwdriver, remove the four countersunk front panel screws.
2. Remove the two rear panel screws that hold the rear 68-pin connector.
3. Hold the front panel and slide the assembly out of the metal case.
4. Set jumper W1 as needed.
5. Reassemble the TC-2190, following this procedure in reverse order. Do not overtighten the screws.

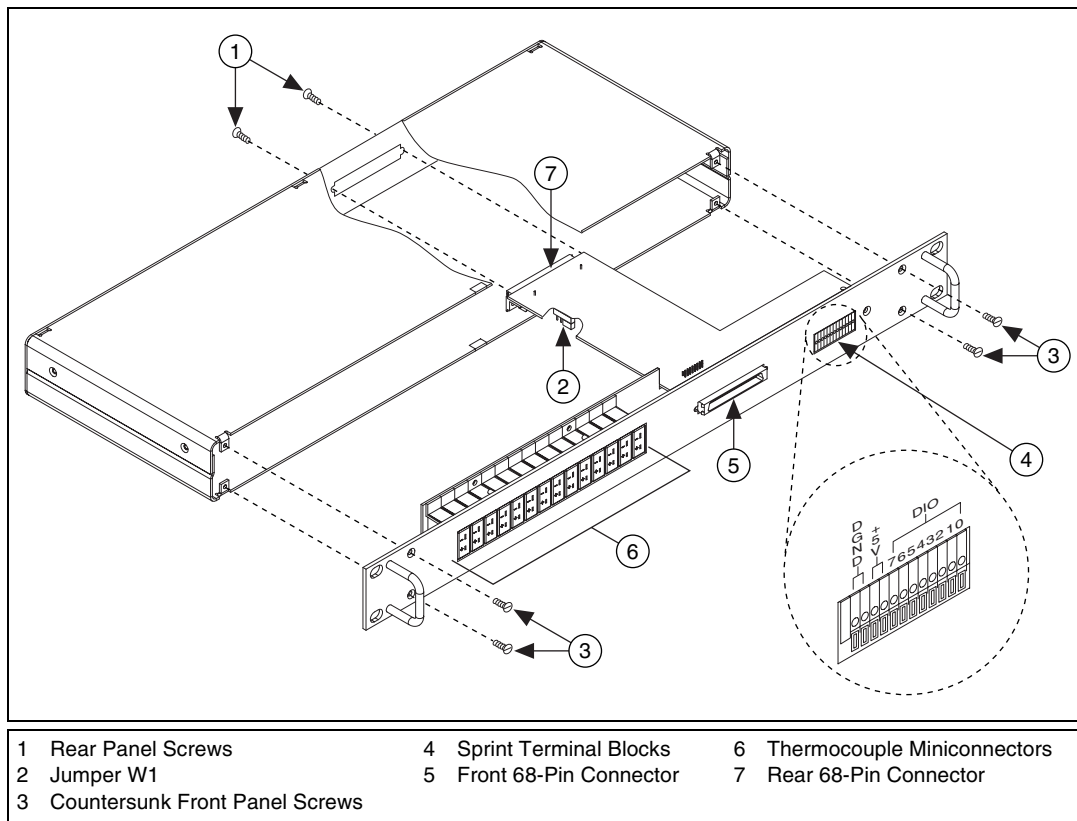

Figure 1. TC-2190 Parts Locator Diagram

Connecting the Signals

Refer to the *NI 435X User Manual* for examples on how to connect to the signals.

Connecting Thermocouples

Insert the thermocouple miniconnector to the mating miniconnector on the TC-2190. Each miniconnector is keyed; that is, it has two spades of different widths so that you can insert the thermocouple in only one way.

Do not force the miniconnector. If you encounter difficulty while inserting the miniconnector, check whether the polarity is correct.

Connecting Digital I/O Signals

Refer to Figure 1 as you complete the following steps to connect the digital signals to the TC-2190:

1. Use a wire cutter and wire insulation stripper to strip the wire ends as necessary to connect them to terminal blocks. You can use up to 20 AWG wire for connecting signals.
2. Push the spring below the DIO terminal block with a 1/8 in. flathead screwdriver to open the terminal block clasp. Keep the spring pressed through step 3.
3. Insert the stripped wires into the terminal blocks.
4. Release the spring.

The wire should be firmly connected.

Connecting the TC-2190 to the NI 435X

Before installing the TC-2190, make sure you have set jumper W1 correctly for the application.

You can mount the TC-2190 into a 19 in. rack or place it on a workbench near the NI 435X. If you do not rack-mount the TC-2190, attach the four adhesive rubber feet included in this kit to the TC-2190 to keep it stationary.



Note To minimize the temperature gradient inside the terminal block and thus maintain its isothermal nature for accurate cold-junction compensation, place the accessory away from extreme temperature differentials.

Refer to Figure 2 as you complete the following steps to connect the TC-2190 to the NI 435X:

1. Connect one end of the SH6868 or R6868 cable to the TC-2190 connector on either the front or the back, as desired. The two connectors should snap together.
2. Attach the connector on the other end of the SH6868 or R6868 cable to the NI 435X I/O connector.

To disconnect the cable from the TC-2190, push the two ejector ears on the cable backshell and gently pull on the backshell. The cable should pop out. Do not pull the cable.



Caution The connectors of both the TC-2190 and the NI 435X are keyed. Do not force the cable. If you encounter difficulty, check whether the polarity is correct.

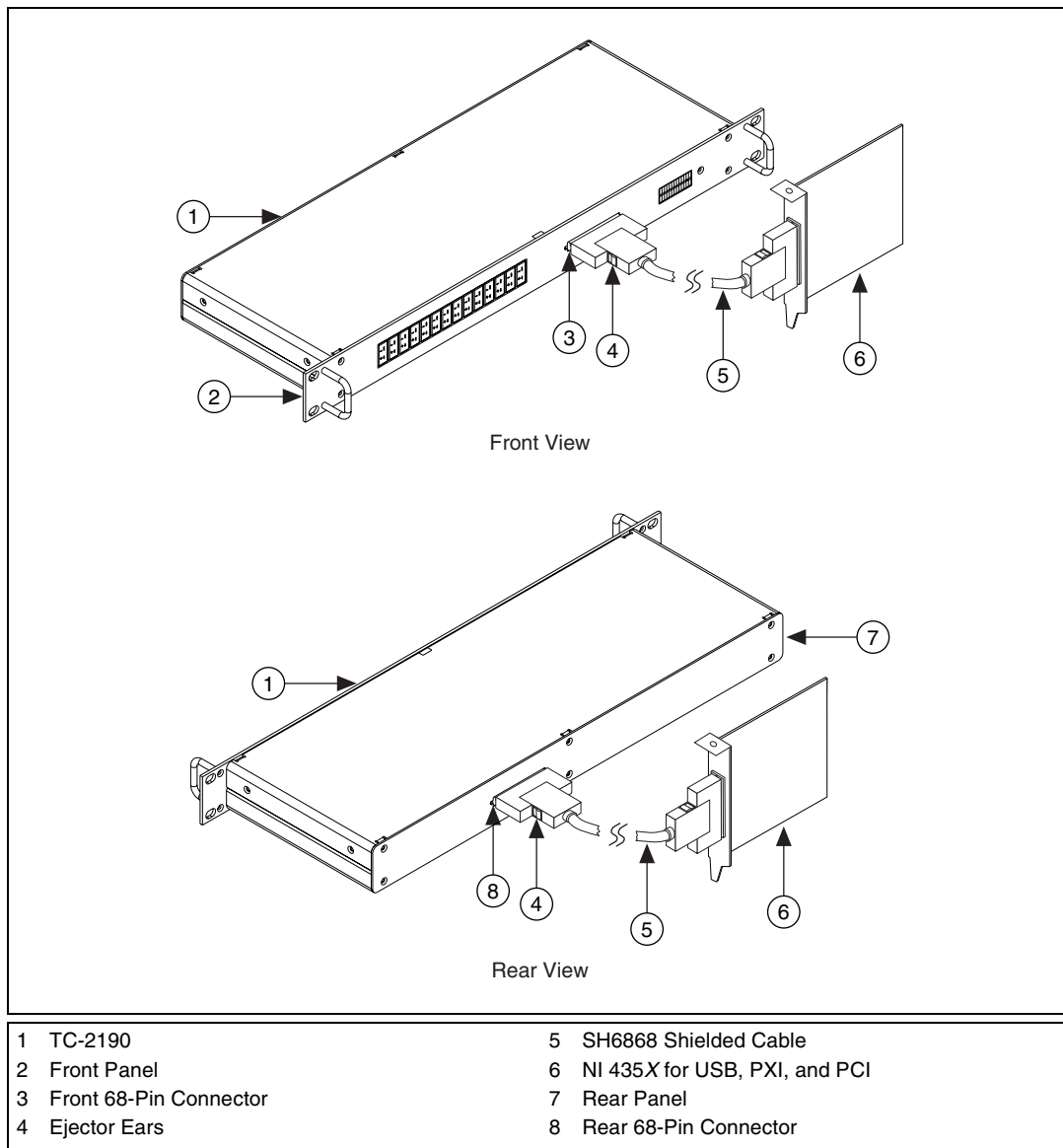

Figure 2. Connecting the TC-2190 to the NI 435X

Cold-Junction Temperature Sensor

The TC-2190 cold-junction temperature sensor consists of a precision thermistor excited by the 25 μA current source on the NI 435X. At 25 $^{\circ}\text{C}$, the resistance of the thermistor is 5,000 Ω . The thermistor resistance varies from 16,305 to 1,492 Ω over the 0 to 55 $^{\circ}\text{C}$ temperature range. The corresponding sensor output voltage varies from 408 to 37 mV over this temperature range.

To select and measure the temperature sensor, refer to the data acquisition software documentation for programming information.

Alternatively, you can use the following formulas to convert the cold-junction sensor voltage to cold-junction temperature:

$$T(^{\circ}\text{C}) = T_K - 273.15$$

where T_K is the temperature in Kelvin.

$$T_K = \frac{1}{a + b \cdot \ln R_T + c \cdot (\ln R_T)^3}$$

$$a = 1.295361 \times 10^{-3}$$

$$b = 2.343159 \times 10^{-4}$$

$$c = 1.018703 \times 10^{-7}$$

R_T = resistance of the thermistor in ohms

$$T(^{\circ}\text{F}) = \frac{T(^{\circ}\text{C}) \cdot 9}{5} + 32$$

where $T(^{\circ}\text{F})$ and $T(^{\circ}\text{C})$ are the temperature readings in degrees Fahrenheit and degrees Celsius, respectively.



Note When you have configured the NI 435X DAQ device with the correct accessory in Measurement & Automation Explorer, NI-DAQ can automatically perform cold-junction compensation on measurements taken on thermocouple channels.

Specifications

Cold-junction sensor accuracy¹..... 0.06 °C from 15 to 35 °C;
0.2 °C from 0 to 15 °C
and 35 to 55 °C

Maximum working voltage²
(signal + common mode) Each input should remain
within ±42 V of ground

Safety

The TC-2190 meets the requirements of the following standards for safety and electrical equipment for measurement, control, and laboratory use:

- EN 61010-1, IEC 61010-1
- UL 3121-1
- CAN/CSA C22.2 No. 1010.1



Note For UL and other safety certifications refer to the product label or to ni.com.

Electromagnetic Compatibility

CE, C-Tick, and FCC Part 15 (Class A) Compliant

Electromagnetic emissions..... EN 55011, ISM Group I,
Class A at 10 m
FCC Part 15A above 1 GHz

Electromagnetic immunity Evaluated to EN 61326-1;
A1:1998, Table 1



Note For full EMC compliance, you must operate this device with shielded cabling. In addition, all covers and filler panels must be installed. Refer to the *Read Me First: Safety and Radio-Frequency Interference* document for FCC Regulatory statements and related information.

¹ Includes only the thermistor accuracy. The combined effects of the temperature sensor accuracy, as well as the current source accuracy due to tolerances in all components in the NI 435X, the effects caused by temperature and loading, and self-heating and current leakage are discussed in the *NI 435X User Manual*.

² Refer to the NI 435X maximum working voltage specification in Appendix A, *Specifications*, of the *NI 435X User Manual*; use the lower number of the two.

CE Compliance

The TC-2190 meets the following amended essential requirements of applicable European Directives for CE marking:

- Low-Voltage Directive (safety): 73/23/EEC
- Electromagnetic Compatibility Directive (EMC): 89/336/EEC



Note Refer to the Declaration of Conformity (DoC) for this product for any additional regulatory compliance information. To obtain the DoC for this product, click **Declaration of Conformity** at ni.com/hardref.nsf/. This Web site lists the DoCs by product family. Select the appropriate product family, followed by the product, and a link appears to the DoC in Adobe Acrobat format. Click the Acrobat icon to download or read the DoC.

Technical Support Resources

NI Web Support

NI Web support is your first stop for help in solving installation, configuration, and application problems and questions. Online problem-solving and diagnostic resources include frequently asked questions, knowledge bases, product-specific troubleshooting wizards, manuals, drivers, software updates, and more. Web support is available through the Technical Support section of ni.com.

Worldwide Support

National Instruments has offices located around the world to help address your support needs. You can access our branch office Web sites from the Worldwide Offices section of ni.com. Branch office Web sites provide up-to-date contact information, support phone numbers, email addresses, and current events.

If you have searched the technical support resources on our Web site and still cannot find the answers you need, contact your local office or National Instruments corporate. For telephone support in the United States, dial 512 795 8248. For telephone support outside the United States, contact your local branch office:

Australia 03 9879 5166, Austria 0662 45 79 90 0, Belgium 02 757 00 20,
Brazil 55 11 3262 3599, Canada (Calgary) 403 274 9391,
Canada (Montreal) 514 288 5722, Canada (Ottawa) 613 233 5949,
Canada (Québec) 514 694 8521, Canada (Toronto) 905 785 0085,
China 86 21 6555 7838, Czech Republic 02 2423 5774,
Denmark 45 76 26 00, Finland 09 725 725 11, France 01 48 14 24 24,
Germany 089 741 31 30, Greece 01 42 96 427, Hong Kong 2645 3186,
India 91 80 4190000, Israel 03 6393737, Italy 02 413091,

Japan 03 5472 2970, Korea 02 3451 3400, Malaysia 603 9596711,
Mexico 001 800 010 0793, Netherlands 0348 433466,
New Zealand 09 914 0488, Norway 32 27 73 00, Poland 22 3390 150,
Portugal 210 311 210, Russia 095 238 7139, Singapore 65 6 226 5886,
Slovenia 3 425 4200, South Africa 11 805 8197, Spain 91 640 0085,
Sweden 08 587 895 00, Switzerland 056 200 51 51,
Taiwan 02 2528 7227, United Kingdom 01635 523545