

COMPREHENSIVE SERVICES

We offer competitive repair and calibration services, as well as easily accessible documentation and free downloadable resources.

SELL YOUR SURPLUS

We buy new, used, decommissioned, and surplus parts from every NI series. We work out the best solution to suit your individual needs.

 Sell For Cash  Get Credit  Receive a Trade-In Deal

OBSOLETE NI HARDWARE IN STOCK & READY TO SHIP

We stock **New**, **New Surplus**, **Refurbished**, and **Reconditioned** NI Hardware.



Bridging the gap between the manufacturer and your legacy test system.

 1-800-915-6216

 www.apexwaves.com

 sales@apexwaves.com

All trademarks, brands, and brand names are the property of their respective owners.

Request a Quote

 **CLICK HERE**

PCI-4451

DAQ

PCI-4451/4452/4453/4454 User Manual

Dynamic Signal Acquisition Device
for PCI

Worldwide Technical Support and Product Information

www.ni.com

National Instruments Corporate Headquarters

11500 North Mopac Expressway Austin, Texas 78759-3504 USA Tel: 512 794 0100

Worldwide Offices

Australia 03 9879 5166, Austria 0662 45 79 90 0, Belgium 02 757 00 20, Brazil 011 284 5011,
Canada (Calgary) 403 274 9391, Canada (Ontario) 905 785 0085, Canada (Québec) 514 694 8521,
China 0755 3904939, Denmark 45 76 26 00, Finland 09 725 725 11, France 01 48 14 24 24,
Germany 089 741 31 30, Greece 30 1 42 96 427, Hong Kong 2645 3186, India 91805275406,
Israel 03 6120092, Italy 02 413091, Japan 03 5472 2970, Korea 02 596 7456, Mexico (D.F.) 5 280 7625,
Mexico (Monterrey) 8 357 7695, Netherlands 0348 433466, New Zealand 09 914 0488, Norway 32 27 73 00,
Poland 0 22 528 94 06, Portugal 351 1 726 9011, Singapore 2265886, Spain 91 640 0085,
Sweden 08 587 895 00, Switzerland 056 200 51 51, Taiwan 02 2528 7227, United Kingdom 01635 523545

For further support information, see the *Technical Support Resources* appendix. To comment on the documentation, send e-mail to techpubs@ni.com

© Copyright 1998, 2000 National Instruments Corporation. All rights reserved.

Important Information

Warranty

The PCI-4451, PCI-4452, PCI-4453, and PCI-4454 are warranted against defects in materials and workmanship for a period of one year from the date of shipment, as evidenced by receipts or other documentation. National Instruments will, at its option, repair or replace equipment that proves to be defective during the warranty period. This warranty includes parts and labor.

The media on which you receive National Instruments software are warranted not to fail to execute programming instructions, due to defects in materials and workmanship, for a period of 90 days from date of shipment, as evidenced by receipts or other documentation. National Instruments will, at its option, repair or replace software media that do not execute programming instructions if National Instruments receives notice of such defects during the warranty period. National Instruments does not warrant that the operation of the software shall be uninterrupted or error free.

A Return Material Authorization (RMA) number must be obtained from the factory and clearly marked on the outside of the package before any equipment will be accepted for warranty work. National Instruments will pay the shipping costs of returning to the owner parts which are covered by warranty.

National Instruments believes that the information in this document is accurate. The document has been carefully reviewed for technical accuracy. In the event that technical or typographical errors exist, National Instruments reserves the right to make changes to subsequent editions of this document without prior notice to holders of this edition. The reader should consult National Instruments if errors are suspected. In no event shall National Instruments be liable for any damages arising out of or related to this document or the information contained in it.

EXCEPT AS SPECIFIED HEREIN, NATIONAL INSTRUMENTS MAKES NO WARRANTIES, EXPRESS OR IMPLIED, AND SPECIFICALLY DISCLAIMS ANY WARRANTY OF MERCHANTABILITY OR FITNESS FOR A PARTICULAR PURPOSE. CUSTOMER'S RIGHT TO RECOVER DAMAGES CAUSED BY FAULT OR NEGLIGENCE ON THE PART OF NATIONAL INSTRUMENTS SHALL BE LIMITED TO THE AMOUNT THEREOF PAID BY THE CUSTOMER. NATIONAL INSTRUMENTS WILL NOT BE LIABLE FOR DAMAGES RESULTING FROM LOSS OF DATA, PROFITS, USE OF PRODUCTS, OR INCIDENTAL OR CONSEQUENTIAL DAMAGES, EVEN IF ADVISED OF THE POSSIBILITY THEREOF. This limitation of the liability of National Instruments will apply regardless of the form of action, whether in contract or tort, including negligence. Any action against National Instruments must be brought within one year after the cause of action accrues. National Instruments shall not be liable for any delay in performance due to causes beyond its reasonable control. The warranty provided herein does not cover damages, defects, malfunctions, or service failures caused by owner's failure to follow the National Instruments installation, operation, or maintenance instructions; owner's modification of the product; owner's abuse, misuse, or negligent acts; and power failure or surges, fire, flood, accident, actions of third parties, or other events outside reasonable control.

Copyright

Under the copyright laws, this publication may not be reproduced or transmitted in any form, electronic or mechanical, including photocopying, recording, storing in an information retrieval system, or translating, in whole or in part, without the prior written consent of National Instruments Corporation.

Trademarks

ComponentWorks™, CVI™, DAQ-STC™, LabVIEW™, Measure™, MITE™, National Instruments™, ni.com™, NI-DAQ™, RTSI™, SCXI™, and VirtualBench™ are trademarks of National Instruments Corporation.

ICP® is a registered trademark of PCB Piezotronics, Inc. Other product and company names mentioned herein are trademarks or trade names of their respective companies.

WARNING REGARDING USE OF NATIONAL INSTRUMENTS PRODUCTS

(1) NATIONAL INSTRUMENTS PRODUCTS ARE NOT DESIGNED WITH COMPONENTS AND TESTING FOR A LEVEL OF RELIABILITY SUITABLE FOR USE IN OR IN CONNECTION WITH SURGICAL IMPLANTS OR AS CRITICAL COMPONENTS IN ANY LIFE SUPPORT SYSTEMS WHOSE FAILURE TO PERFORM CAN REASONABLY BE EXPECTED TO CAUSE SIGNIFICANT INJURY TO A HUMAN.

(2) IN ANY APPLICATION, INCLUDING THE ABOVE, RELIABILITY OF OPERATION OF THE SOFTWARE PRODUCTS CAN BE IMPAIRED BY ADVERSE FACTORS, INCLUDING BUT NOT LIMITED TO FLUCTUATIONS IN ELECTRICAL POWER SUPPLY, COMPUTER HARDWARE MALFUNCTIONS, COMPUTER OPERATING SYSTEM SOFTWARE FITNESS, FITNESS OF COMPILERS AND DEVELOPMENT SOFTWARE USED TO DEVELOP AN APPLICATION, INSTALLATION ERRORS, SOFTWARE AND HARDWARE COMPATIBILITY PROBLEMS, MALFUNCTIONS OR FAILURES OF ELECTRONIC MONITORING OR CONTROL DEVICES, TRANSIENT FAILURES OF ELECTRONIC SYSTEMS (HARDWARE AND/OR SOFTWARE), UNANTICIPATED USES OR MISUSES, OR ERRORS ON THE PART OF THE USER OR APPLICATIONS DESIGNER (ADVERSE FACTORS SUCH AS THESE ARE HEREAFTER COLLECTIVELY TERMED "SYSTEM FAILURES"). ANY APPLICATION WHERE A SYSTEM FAILURE WOULD CREATE A RISK OF HARM TO PROPERTY OR PERSONS (INCLUDING THE RISK OF BODILY INJURY AND DEATH) SHOULD NOT BE RELIANT SOLELY UPON ONE FORM OF ELECTRONIC SYSTEM DUE TO THE RISK OF SYSTEM FAILURE. TO AVOID DAMAGE, INJURY, OR DEATH, THE USER OR APPLICATION DESIGNER MUST TAKE REASONABLY PRUDENT STEPS TO PROTECT AGAINST SYSTEM FAILURES, INCLUDING BUT NOT LIMITED TO BACK-UP OR SHUT DOWN MECHANISMS. BECAUSE EACH END-USER SYSTEM IS CUSTOMIZED AND DIFFERS FROM NATIONAL INSTRUMENTS' TESTING PLATFORMS AND BECAUSE A USER OR APPLICATION DESIGNER MAY USE NATIONAL INSTRUMENTS PRODUCTS IN COMBINATION WITH OTHER PRODUCTS IN A MANNER NOT EVALUATED OR CONTEMPLATED BY NATIONAL INSTRUMENTS, THE USER OR APPLICATION DESIGNER IS ULTIMATELY RESPONSIBLE FOR VERIFYING AND VALIDATING THE SUITABILITY OF NATIONAL INSTRUMENTS PRODUCTS WHENEVER NATIONAL INSTRUMENTS PRODUCTS ARE INCORPORATED IN A SYSTEM OR APPLICATION, INCLUDING, WITHOUT LIMITATION, THE APPROPRIATE DESIGN, PROCESS AND SAFETY LEVEL OF SUCH SYSTEM OR APPLICATION.

Contents

About This Manual

How To Use the Manual Set.....	xi
Conventions	xi
Related Documentation.....	xii

Chapter 1

Introduction

About the PCI-445X.....	1-1
What You Need to Get Started	1-2
Unpacking	1-3
Software Programming Choices	1-3
National Instruments Application Software	1-3
NI-DAQ Driver Software	1-4
Optional Equipment	1-5
Custom Cabling	1-6
Analog Cables	1-6
Analog Accessories	1-7
Digital Cables (PCI-4451/4452 Only).....	1-7

Chapter 2

Installation and Configuration

Software Installation	2-1
Hardware Installation.....	2-1
Device Configuration.....	2-2

Chapter 3

Hardware Overview

Analog Input	3-4
Input Mode	3-4
Input Coupling.....	3-4
Input Polarity and Input Range.....	3-4
Considerations for Selecting Input Ranges	3-5
Analog Output (PCI-4451/4453 Only)	3-6
Output Mode.....	3-6
Output Polarity and Output Range	3-7
Trigger	3-8
RTSI Triggers	3-12

Digital I/O (PCI-4451/4452 Only)	3-12
Timing Signal Routing	3-13
Programmable Function Inputs (PCI-4451/4452 Only).....	3-13
Device and RTSI Clocks.....	3-14
Selecting Sample/Update Clock Frequency	3-14
Device Configuration Issues.....	3-15

Chapter 4

Signal Connections

I/O Connectors.....	4-1
Analog I/O Connector Signal Descriptions	4-2
Digital I/O Connector Signal Descriptions	4-8
Analog Input Signal Connections.....	4-12
Types of Signal Sources	4-14
Floating Signal Sources	4-14
Ground-Referenced Signal Sources	4-14
Analog Output Signal Connections	4-14
Analog Power Connections	4-16
Digital I/O Signal Connections (PCI-4451/4452 Only)	4-17
Digital Power Connections (PCI-4451/4452 Only)	4-18
Timing Connections	4-18
Programmable Function Input Connections (PCI-4451/4452 Only)	4-19
Acquisition Timing Connections	4-19
PFI0/TRIG1 (EXT_TRIG) Signal	4-20
PFI1/TRIG2 (PRETRIG) Signal	4-21
CONVERT* Signal	4-21
EXTSTROBE* Signal (PCI-4451/4452 Only).....	4-21
Waveform Generation Timing Connections	4-22
WFTRIG Signal.....	4-22
UPDATE* Signal	4-22
General-Purpose Timing Signal Connections.....	4-22
GPCTR0_SOURCE Signal	4-23
GPCTR0_GATE Signal	4-23
GPCTR0_OUT Signal.....	4-24
GPCTR0_UP_DOWN Signal (PCI-4451/4452 Only)	4-24
GPCTR1_SOURCE Signal (PCI-4451/4452 Only)	4-24
GPCTR1_GATE Signal (PCI-4451/4452 Only)	4-25
GPCTR1_OUT Signal (PCI-4451/4452 Only).....	4-26
GPCTR1_UP_DOWN Signal (PCI-4451/4452 Only)	4-26
FREQ_OUT Signal (PCI-4451/4452 Only)	4-28
Field Wiring Considerations.....	4-28

Chapter 5 Calibration

Loading Calibration Constants	5-1
Self-Calibration.....	5-2
External Calibration.....	5-2
Traceable Recalibration	5-3

Chapter 6 Theory of Analog Operation

Functional Overview.....	6-1
Analog Input Circuitry	6-1
Input Coupling.....	6-3
Calibration	6-3
Antialias Filtering.....	6-3
The ADC	6-9
Noise.....	6-10
Analog Output Circuitry (PCI-4451/4453 Only).....	6-11
Anti-Image Filtering.....	6-12
The DAC	6-14
Calibration	6-14
Mute Feature.....	6-15

Appendix A Specifications

Appendix B Pin Connections

Appendix C Technical Support Resources

Glossary

Index

Figures

Figure 1-1.	The Relationship between the Programming Environment, NI-DAQ, and Your Hardware.....	1-5
Figure 3-1.	Digital Function Block Diagram.....	3-1
Figure 3-2.	PCI-4451/4452 Analog Function Block Diagram	3-2
Figure 3-3.	PCI-4453/4454 Analog Function Block Diagram	3-3
Figure 3-4.	Below-Low-Level Triggering Mode.....	3-9
Figure 3-5.	Above-High-Level Triggering Mode.....	3-9
Figure 3-6.	Inside-Region Triggering Mode	3-10
Figure 3-7.	High-Hysteresis Triggering Mode	3-10
Figure 3-8.	Low-Hysteresis Triggering Mode.....	3-10
Figure 3-9.	RTSI Bus Signal Connection	3-12
Figure 4-1.	Analog Pin Connections for the PCI-4451/4452	4-2
Figure 4-2.	Analog Pin Connections for the PCI-4453/4454	4-5
Figure 4-3.	Digital Pin Connections	4-8
Figure 4-4.	Analog Input Stage of the PCI-4451/4452.....	4-12
Figure 4-5.	Analog Input Stage of the PCI-4453/4454.....	4-13
Figure 4-6.	Analog Output Channel Block Diagram for the PCI-4451	4-15
Figure 4-7.	Analog Output Channel Block Diagram for the PCI-4453.....	4-16
Figure 4-8.	Digital I/O Connections	4-17
Figure 4-9.	Typical Posttriggered Acquisition	4-19
Figure 4-10.	Typical Pretriggered Acquisition	4-20
Figure 4-11.	EXTSTROBE* Signal Timing	4-22
Figure 4-12.	GPCTR0_SOURCE Signal Timing	4-23
Figure 4-13.	GPCTR0_OUT Signal Timing	4-24
Figure 4-14.	GPCTR1_SOURCE Signal Timing	4-25
Figure 4-15.	GPCTR1_OUT Signal Timing	4-26
Figure 4-16.	GPCTR Timing Summary	4-27
Figure 6-1.	Input Frequency Response.....	6-5
Figure 6-2.	Input Frequency Response Near the Cutoff.....	6-6
Figure 6-3.	Alias Rejection at the Oversample Rate for the PCI-4451/4452	6-7
Figure 6-4.	Alias Rejection at the Oversample Rate for the PCI-4453/4454	6-8
Figure 6-5.	Comparison of a Clipped Signal to a Proper Signal	6-9
Figure 6-6.	Signal Spectra in the DAC	6-13
Figure A-1.	PCI-4451/4452 Idle Channel Noise (Typical)	A-5
Figure B-1.	DB-25 Pinout for the SHC68-DB25 Cable.....	B-1
Figure B-2.	68-Pin Digital Connector for Any Digital Accessory.....	B-2

Tables

Table 3-1.	Actual Input Range and Measurement Resolution of the PCI-4451/4452	3-5
Table 3-2.	Actual Output Range and Resolution of the PCI-4451	3-7
Table 4-1.	Analog I/O Connector Pin Assignment for the PCI-4451/4452.....	4-3
Table 4-2.	Analog I/O Signal Summary for the PCI-4451/4452.....	4-4
Table 4-3.	Analog I/O Connector Pin Assignment for the PCI-4453/4454.....	4-6
Table 4-4.	Analog I/O Signal Summary for the PCI-4453/4454.....	4-7
Table 4-5.	Digital I/O Connector Pin Assignment	4-9
Table 4-6.	Digital I/O Signal Summary.....	4-11

About This Manual

This manual describes the electrical and mechanical aspects of the PCI-4451/4452/4453/4454 (PCI-445X) devices and contains information concerning their operation. Unless otherwise noted, the text applies to all devices.

The PCI-445X are high-performance, high-accuracy analog input devices for the PCI bus, and all support external trigger functions. In addition, the PCI-4451 and PCI-4453 are analog output devices, and the PCI-4451 and PCI-4452 devices support digital I/O (DIO) and counter/timer functions.

How To Use the Manual Set

The *PCI-4451/4452/4453/4454 User Manual* is one piece of the documentation set for your DAQ system. You could have any of several types of manuals depending on the hardware and software in your system. Use the manuals you have as follows:

- Software documentation—You may have both application software and NI-DAQ software documentation. National Instruments application software includes LabVIEW, LabWindows/CVI, ComponentWorks, Measure, and VirtualBench. After you set up your hardware system, use either your application software documentation or the NI-DAQ documentation to help you write your application.
- Accessory installation guides or manuals—If you are using accessory products, read the terminal block and cable assembly installation guides. They explain how to physically connect the relevant pieces of the system. Consult these guides when you are making your connections.

Conventions



The following conventions are used in this manual:

<>

Angle brackets containing numbers separated by an ellipsis represent a range of values associated with a bit or signal name—for example, +ACH<0..3>.

◆

The ◆ symbol indicates that the text following it applies only to a specific product, a specific operating system, or a specific software version.

*	An asterisk following a signal name denotes an active low signal.
	This icon denotes a note, which alerts you to important information.
	This icon denotes a caution, which advises you of precautions to take to avoid injury, data loss, or a system crash.
bold	Bold text denotes items that you must select or click on in the software, such as menu items and dialog box options. Bold text also denotes parameter names.
DSA	DSA refers to dynamic signal acquisition.
<i>italic</i>	Italic text denotes variables, emphasis, a cross reference, or an introduction to a key concept. This font also denotes text that is a placeholder for a word or value that you must supply.
monospace	Text in this font denotes text or characters that you should enter from the keyboard, sections of code, programming examples, and syntax examples. This font is also used for the proper names of disk drives, paths, directories, programs, subprograms, subroutines, device names, functions, operations, variables, filenames and extensions, and code excerpts.
SE	SE means referenced single-ended (RSE) for the purposes of this manual.

Related Documentation

The following documents contain information you may find helpful:

- *BNC-2140 User Manual*
- *BNC-2142 Installation Guide*
- National Instruments Application Note 025, *Field Wiring and Noise Considerations for Analog Signals*
- *PCI Local Bus Specification* Revision 2.0

Introduction

This chapter describes the PCI-4451/4452/4453/4454 (PCI-445X) devices, lists what you need to get started, explains how to unpack your devices, and describes the optional software and accessories.

About the PCI-445X

The PCI-445X devices are high-performance, high-accuracy analog I/O devices for the PCI bus. These devices are members of the Dynamic Signal Acquisition/Analysis (DSA) product family and are specifically designed for demanding dynamic signal acquisition applications. The PCI-445X family features 16-bit simultaneously sampled input with a maximum rate from 51.2 kS/s to 204.8 kS/s, optional 24-bit simultaneously updated output at up to 51.2 kS/s, an optional eight lines of TTL-compatible digital I/O, two 24-bit counter/timers for timing I/O, and multiple triggering modes including external digital trigger. See Appendix A, [Specifications](#), for details about your PCI-445X.

The analog input and analog output circuitry both use oversampling delta-sigma modulating converters. Delta-sigma converters are inherently linear, provide built-in brick-wall anti-aliasing/imaging filters, and have specifications that exceed other conventional technology for this application with regard to total harmonic distortion (THD), signal-to-noise ratio (SNR), and amplitude flatness. You can use these high-quality specifications and features to acquire or generate signals with high accuracy and fidelity without introducing noise or out-of-band aliases.

Applications for PCI-445X devices include audio signal processing and analysis, acoustics and speech research, sonar, audio frequency test and measurement, vibration and modal analysis, or any application requiring high-fidelity signal acquisition or generation.

What You Need to Get Started

To set up and use your PCI-445X, you need the following:

- One of the following PCI-445X devices:
 - PCI-4451
 - PCI-4452
 - PCI-4453
 - PCI-4454
- This manual
- One or more of the following software packages and documentation:
 - LabVIEW for Windows
 - LabVIEW for Mac OS (PCI-4451/4452 only)
 - LabWindows/CVI for Windows
 - VirtualBench-DSA
 - ComponentWorks
 - Measure
- One of the following software packages and documentation:
 - NI-DAQ for PC Compatibles
 - NI-DAQ for Mac OS (PCI-4451/4452 only)
- Your computer, with an available PCI slot
- One of the following:
 - SHC68-C68-A1 analog cable
 - SHC68-DB25 analog cable for OEM
- One of the following analog accessories and documents:
 - BNC-2140 accessory and the *BNC-2140 User Manual*
 - BNC-2142 accessory and the *BNC-2142 Installation Guide*

Unpacking

Your PCI-445X is shipped in an antistatic plastic package to prevent electrostatic damage to the device. Electrostatic discharge can damage components on the instrument. To avoid such damage in handling the device, take the following precautions:

- Ground yourself with a grounding strap or by holding a grounded object.
- Touch the plastic package to a metal part of your computer chassis before removing the device from the package.
- *Never* touch exposed connector pins.

Remove the device from the package and inspect the device for loose components or any other sign of damage. Notify National Instruments if the device appears damaged in any way. Do *not* install a damaged device into your computer.

Software Programming Choices

You can choose from several options to program and use your National Instruments device. You can use LabVIEW, LabWindows/CVI, VirtualBench-DSA, ComponentWorks, and Measure.

National Instruments Application Software

LabVIEW and LabWindows/CVI are innovative program development software packages for data acquisition and control applications. LabVIEW uses graphical programming, whereas LabWindows/CVI enhances the C programming language. Both packages include extensive libraries for data acquisition, instrument control, data analysis, and graphical data presentation.

LabVIEW features interactive graphics, a state-of-the-art user interface, and a powerful graphical programming language, and includes the LabVIEW Data Acquisition VI Library, a series of *virtual instruments* (VIs) for controlling National Instruments DAQ devices. The LabVIEW Data Acquisition VI Library is functionally equivalent to the NI-DAQ software.

LabWindows/CVI features interactive graphics, a state-of-the-art user interface, and uses the ANSI C programming language. LabWindows/CVI includes The LabWindows/CVI Data Acquisition Library, a series of

functions for using LabWindows/CVI with National Instruments DAQ devices. The LabWindows/CVI Data Acquisition library is functionally equivalent to the NI-DAQ software.

VirtualBench is a suite of VIs that allows you to use your data acquisition products just as you use stand-alone instruments, but with the added benefit of the processing, display, and storage capabilities of PCs. VirtualBench instruments load and save waveform data to disk in a form compatible with popular spreadsheet programs and word processors. A report generation capability complements the raw data storage by adding timestamps, measurements, user names, and comments.

The complete VirtualBench suite contains VirtualBench-Scope, VirtualBench-DSA, VirtualBench-FG, VirtualBench-Arb, VirtualBench-DIO, VirtualBench-DMM, and VirtualBench-Logger. VirtualBench-DSA is a turnkey application you can use to make measurements as you would with a standard dynamic signal analyzer.

ComponentWorks contains tools for data acquisition and instrument control built on NI-DAQ driver software. ComponentWorks provides a higher-level programming interface for building virtual instruments with Visual Basic, Visual C++, Borland Delphi, and Microsoft Internet Explorer. With ComponentWorks, you can use all of the configuration tools, resource management utilities, and interactive control utilities included in NI-DAQ.

Measure is a data acquisition and instrument control add-in for Microsoft Excel. With Measure, you can acquire data directly from plug-in DAQ devices, GPIB instruments, or serial (RS-232) devices. Measure has easy-to-use dialog boxes for configuring your measurements. Your data is placed directly into Excel worksheet cells, from which you can perform your analysis and report generations using the full power and flexibility of Excel.

NI-DAQ Driver Software

The NI-DAQ driver software is included with most National Instruments DAQ hardware. NI-DAQ has an extensive library of functions that you can call from your application programming environment. These functions allow you to use all features of your PCI-445X.

NI-DAQ addresses many of the complex issues between the computer and the DAQ hardware such as programming interrupts. NI-DAQ maintains a consistent software interface among its different versions so that you can change platforms with minimal modifications to your code. Whether you are using LabVIEW, LabWindows/CVI, ComponentWorks, or other

programming languages, your application uses the NI-DAQ driver software, as illustrated in Figure 1-1.

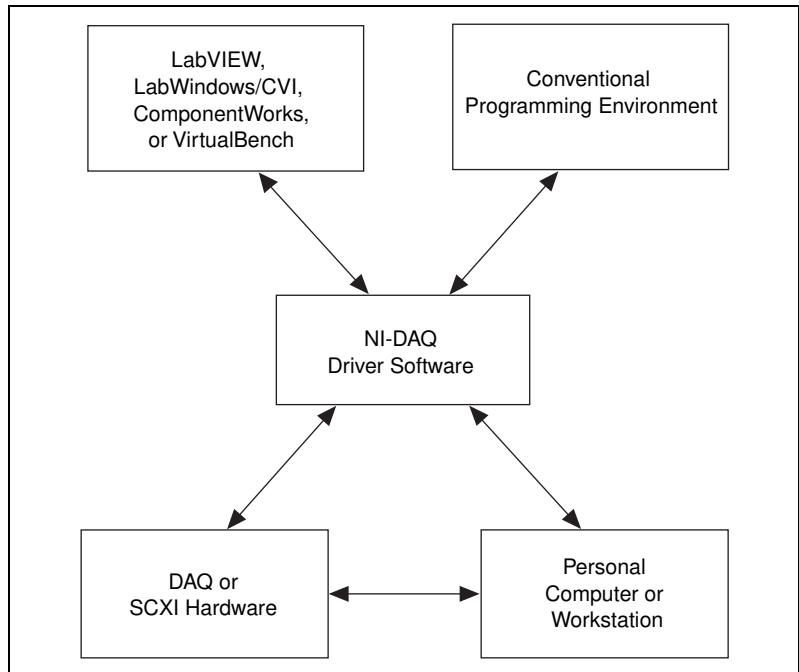

Figure 1-1. The Relationship between the Programming Environment, NI-DAQ, and Your Hardware

Optional Equipment

◆ PCI-4451/4452

National Instruments offers a variety of products to use with your PCI-4451/4452, including these cables and connector blocks:

- SHC50-68 digital cable
- Shielded and DIN rail-mountable 68-pin connector blocks for digital I/O
- RTSI cable for multiboard synchronization and triggering

- ◆ PCI-4453/4454

National Instruments offers optional products to use with your PCI-4453/4454, including these cables and connector blocks:

- SMB-to-BNC cable for external trigger
- RTSI cable for multiboard synchronization and triggering

Custom Cabling

National Instruments offers different types of cables in varying lengths, and the BNC-214X DSA accessories to connect your analog I/O to a PCI-445X device. National Instruments also offers cables of different lengths and accessories to connect your digital I/O signals to the PCI-4451/4452. National Instruments recommends you do not develop your own cabling solution due to the difficulty of working with the high-density connector and the need to maintain high signal integrity. If your application requires that you develop your own cable, follow the guidelines in this section.

Analog Cables

National Instruments recommends using the SHC68-DB25 cable for those applications that require custom accessories. The SHC68-DB25 cable, a shielded 68-position VHDCI connector cabled to a standard DB-25 shell, facilitates the creation of custom termination solutions.

- ◆ PCI-4451/4452

Use shielded twisted-pair wires for each differential analog input or output channel pair. Since the signals are differential, using this type of wire yields the best results.

When connecting the cable shields, be sure to connect the analog input grounds to the AIGND pins and the analog output grounds to the AOGND pins. For connector pin connections and assignments, refer to Figure 4-1, [Analog Pin Connections for the PCI-4451/4452](#) and to Table 4-1, [Analog I/O Connector Pin Assignment for the PCI-4451/4452](#).

- ◆ PCI-4453/4454

When connecting the cable shields, be sure to connect the analog input grounds to the AI_SHLDx pins and the analog output grounds to the AO_SHLDx pins. For connector pin connections and assignments, refer to Figure 4-2, [Analog Pin Connections for the PCI-4453/4454](#) and to Table 4-3, [Analog I/O Connector Pin Assignment for the PCI-4453/4454](#).

Analog Accessories

To create your own accessories for use with the SHC68-C68 cable, you can use an AMP 68-pin right-angle PWB receptacle header, part number 787254-1.

Recommended manufacturer part numbers for the 68-pin mating connector for the cable assembly are as follows:

- AMP 68-position straight cable plug, part number 787131-3
- AMP 68-position backshell with jackscrews, part number 787191-1

Digital Cables (PCI-4451/4452 Only)

To develop your own cable, the mating connector for the digital I/O is a 50-position receptacle. For a connector pinout assignment, refer to Figure 4-3, *Digital Pin Connections* and Table 4-5, *Digital I/O Connector Pin Assignment*. Recommended manufacturer part numbers for this mating connector are as follows:

- 50-position straight cable plug, part number 787131-1
- 50-position backshell with jackscrews, part number 787233-1

Refer to Figure B-2, *68-Pin Digital Connector for Any Digital Accessory*, for pin assignments for digital accessories and cables.

Installation and Configuration

This chapter explains how to install and configure your PCI-445X.

Software Installation



Note Install your software before you install your PCI-445X.

If you are using NI-DAQ, refer to your NI-DAQ release notes and the *DAQ Quick Start Guide*. Find the installation section for your operating system and follow the instructions given there.

If you are using LabVIEW, LabWindows/CVI, or other National Instruments application software, refer to the appropriate release notes. After you have installed your application software, refer to your NI-DAQ release notes and follow the instructions given there for your operating system and application software package.

Hardware Installation

You can install the PCI-445X in any available PCI expansion slot in your computer. However, to achieve the best noise performance, leave as much room as possible between the PCI-445X and other devices and hardware. The following are general installation instructions, but consult your computer user manual or technical reference manual for specific instructions and warnings:

1. Turn off your computer.
2. Remove the cover.
3. Remove the expansion slot cover on the back panel of the computer.
4. Touch a metal part of the computer chassis with your hand and with the anti-static bag containing your PCI-445X.
5. Remove the PCI-445X from the anti-static bag.

6. Insert the PCI-445X into a 5 V PCI slot (PCI slots are normally white in color). It should fit snugly, but *do not force* the device into place.
7. Screw the mounting bracket of the PCI-445X to the back panel rail of the computer.
8. Check the installation to be sure the device is in the slot, and not touching other boards or system components.
9. Replace the cover.
10. Turn on your computer.

The PCI-445X is now installed. You are now ready to configure your device.

Device Configuration

The PCI-445X devices are completely software-configurable, and require two types of configuration: bus-related and data acquisition-related.

The PCI-445X devices are fully compatible with the industry standard *PCI Local Bus Specification Revision 2.0*. The PCI system automatically performs all bus-related configurations and requires no interaction from you. Bus-related configuration includes setting the device base memory address and interrupt channel.

Data acquisition related configuration includes such settings as analog input polarity and range, analog input mode, and others. You can modify these settings through National Instruments application level software, such as LabVIEW, LabWindows/CVI, VirtualBench-DSA, and ComponentWorks, or with driver software such as NI-DAQ.

Hardware Overview

This chapter presents an overview of the hardware functions on your PCI-445X. Figure 3-1 shows a block diagram of the digital functions. The analog function block diagrams are shown in Figures 3-2 and 3-3. The digital and analog function blocks connect through the analog mezzanine bus.

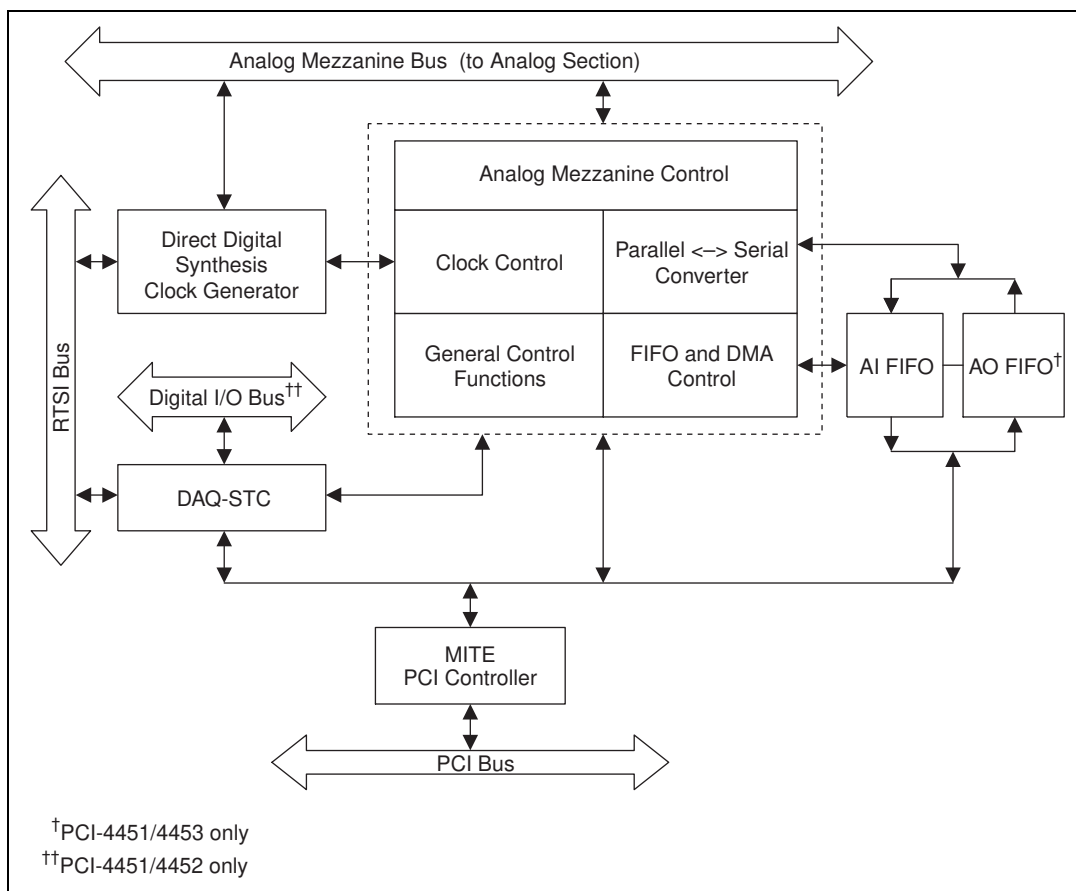

Figure 3-1. Digital Function Block Diagram

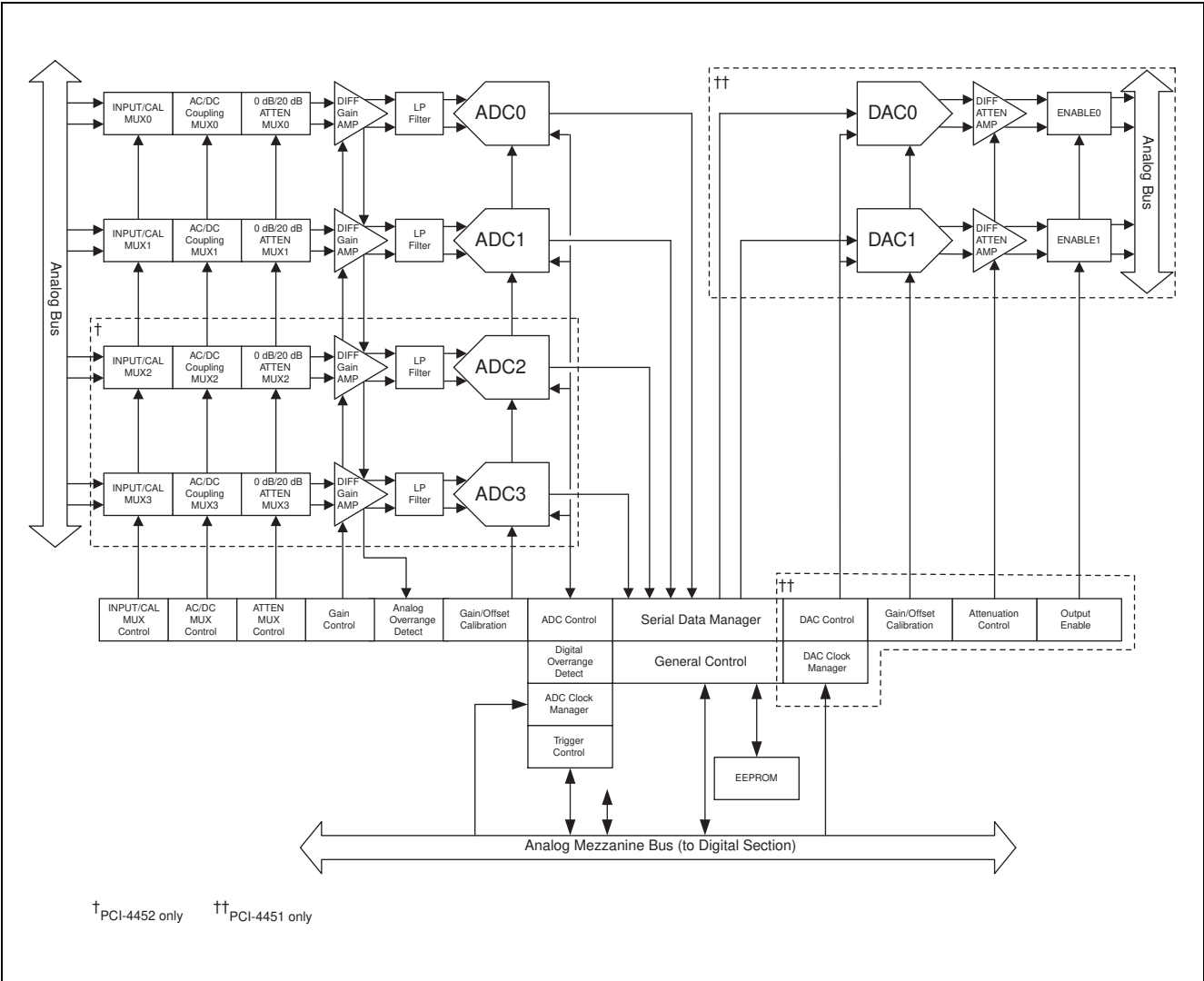

Figure 3-2. PCI-4451/4452 Analog Function Block Diagram

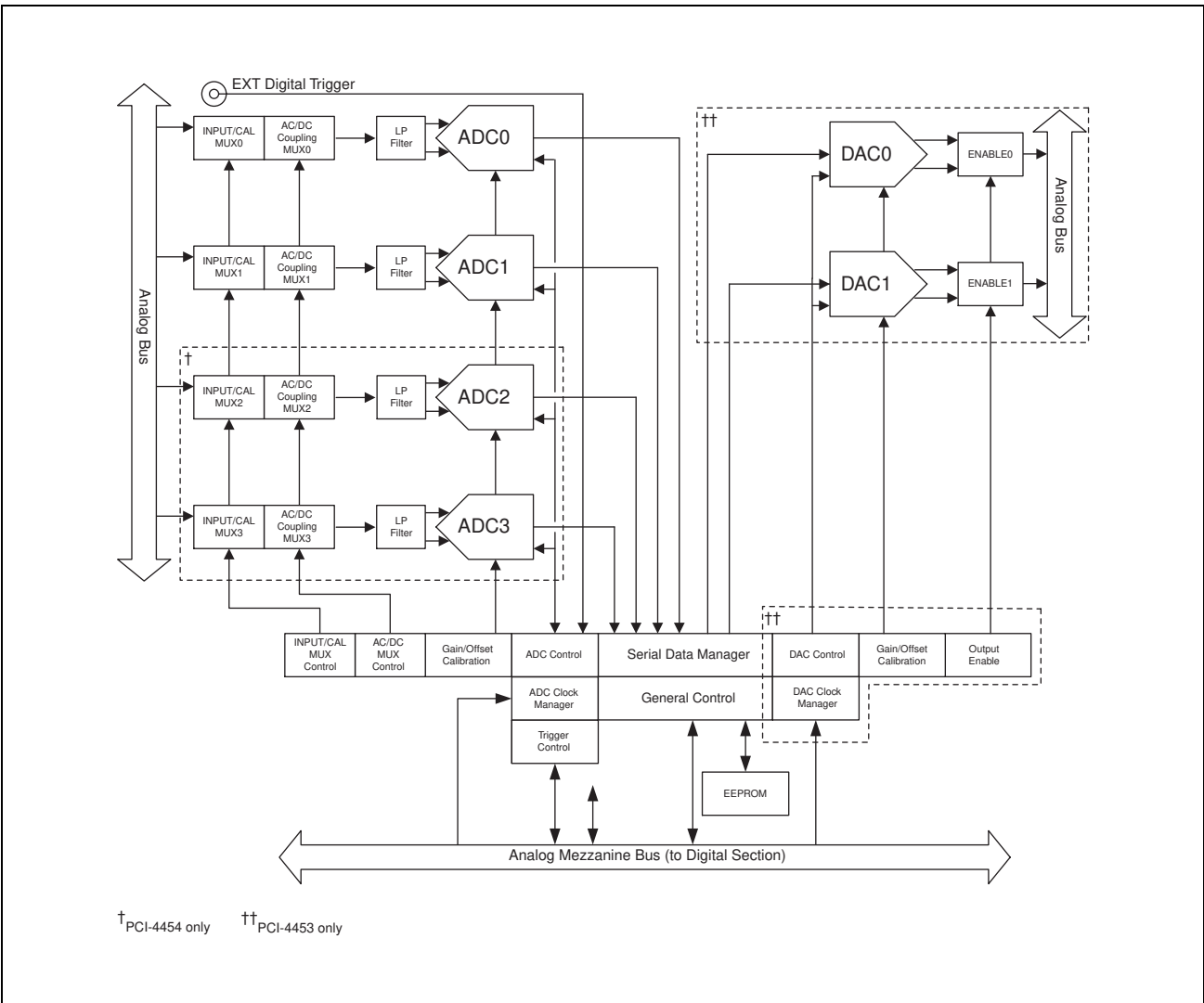

Figure 3-3. PCI-4453/4454 Analog Function Block Diagram

Analog Input

The analog input section of each PCI-445X is software configurable. You can select different analog input configurations through application software. The following sections describe in detail each of the analog input categories.

Input Mode

- ◆ PCI-4451/4452

This device has differential (DIFF) inputs. You can configure the input as a differential or a single ended (SE) channel using the BNC-2140 DSA accessory. For more information, please refer to the *BNC-2140 User Manual*. In DIFF mode, one line connects to the positive input of the channel, and the other connects to the negative input of the same channel. You can connect the differential input to SE or DIFF signals, either floating or ground-referenced. However, grounding the negative input from floating sources can improve the measurement quality by removing the common-mode noise.

- ◆ PCI-4453/4454

This device operates in SE mode using the BNC-2142 DSA accessory. For more information, refer to the *BNC-2142 Installation Guide*.

Input Coupling

The PCI-445X has a software-programmable switch that determines if a capacitor is placed in the signal path. If the switch is set for DC, the capacitor is bypassed, and any DC offset present in the source signal is passed to the ADC. If the source has a significant amount of unwanted offset (bias voltage), you must set the switch for AC coupling to place the capacitor in the signal path and take full advantage of the input signal range.

Input Polarity and Input Range

The PCI-445X operates in bipolar mode. Bipolar input means that the input voltage range is between $-V_{\text{ref}}/2$ and $+V_{\text{ref}}/2$.

- ◆ PCI-4451/4452

This device allows you to configure the range settings of each input channel independently. The software-programmable gain on this device increases

its overall flexibility by matching the input signal ranges to those that the ADC can accommodate. With the proper gain setting, you can use the full resolution of the ADC to measure the input signal. Table 3-1 shows the overall input range and resolution according to the input range configuration and gain used.

Table 3-1. Actual Input Range and Measurement Resolution of the PCI-4451/4452

Linear Gain	Gain	Input Range	Resolution ¹
0.1	-20 dB	$\pm 42.4 \text{ V}^2$	3.0518 mV ²
0.316	-10 dB	$\pm 31.6 \text{ V}$	965.05 μV
1.0	0 dB	$\pm 10.0 \text{ V}$	305.18 μV
3.16	10 dB	$\pm 3.16 \text{ V}$	96.505 μV
10	20 dB	$\pm 1.00 \text{ V}$	30.518 μV
31.6	30 dB	$\pm 0.316 \text{ V}$	9.6505 μV
100	40 dB	$\pm 0.100 \text{ V}$	3.0518 μV
316	50 dB	$\pm 31.6 \text{ mV}$	965.05 nV
1000	60 dB	$\pm 10.0 \text{ mV}$	305.18 nV

¹ The value of 1 LSB of the 16-bit ADC; that is, the voltage increment corresponding to a change of one count in the ADC 16-bit count.

² The actual input range is by design $\pm 100 \text{ V}$; however, the device is not tested or certified to operate in this range. See Appendix A, *Specifications*, for absolute maximum ratings.

All data read from the ADC is interpreted as two's complement format. In two's complement mode, digital data values read from the analog input channel are either positive or negative.

◆ PCI-4453/4454

The PCI-4453/4454 has a bipolar input range of 20 V ($\pm 10 \text{ V}$) at a gain of 1.0 (0 dB) only

Considerations for Selecting Input Ranges

◆ PCI-4451/4452

The input range you select for the PCI-4451/4452 depends on the expected range of the incoming signal. A large input range can accommodate a large signal variation, but reduces the voltage resolution. A smaller input range

improves the voltage resolution, but can result in the input signal going out of range. For best results, match the input range as closely as possible to the expected range of the input signal.

If you do not choose an appropriate input range, the input signal can be clipped and introduce large errors that are easily identified in the frequency spectrum. The PCI-4451/4452 is equipped with overrange detection circuits in both the analog and digital sections of each input channel. These circuits determine if an input signal has exceeded the selected input voltage. Chapter 6, *Theory of Analog Operation*, provides a more in-depth explanation of how overranges can occur.

- ◆ PCI-4453/4454

The PCI-4453/4454 does not feature any range setting capability and is not equipped with overrange detection circuits.



Caution Connections that exceed the rated input voltages can damage the computer and the connected equipment. National Instruments is *not* liable for any damages resulting from such connections.

Analog Output (PCI-4451/4453 Only)

The analog output section of the PCI-4451/4453 is software-configurable. You can select different analog output configurations through application software designed to control the PCI-4451/4453. The following sections describe in detail each of the analog output categories. The PCI-4451/4453 has two channels of analog output voltage at the I/O connector.

Output Mode

- ◆ PCI-4451

The PCI-4451 has DIFF outputs. You can configure the outputs as an SE channel using the BNC-2140 DSA accessory. For more information, refer to the *BNC-2140 User Manual*. In DIFF mode, one line connects to the positive input of the channel and the other connects to the negative input of that same channel. You can connect the differential output to either SE or DIFF loads, either floating or ground-referenced. However, grounding the negative output is recommended when driving floating single-ended loads.

◆ PCI-4453

The PCI-4453 operates in SE mode using the BNC-2142 DSA accessory. For more information, refer to the *BNC-2142 Installation Guide*.

Output Polarity and Output Range

The PCI-4451/4453 operates in bipolar mode. Bipolar output means that the output voltage range is between $-V_{\text{ref}}/2$ and $+V_{\text{ref}}/2$. The PCI-4451 has a bipolar output range of 20 V (± 10 V) for an attenuation of 1.0 (0 dB).

All data written to the DACs are interpreted as two's complement format. In two's complement mode, data values written to the analog output channel are either positive or negative.



Note When the DACs no longer have data written to them, they automatically retransmit the last data point they received. If you are expecting the data to return to 0 V or any other voltage level, you *must* append the data to make it do so.

◆ PCI-4451

You can configure the range settings on each output channel independently. The software-programmable attenuation on these devices increases their overall flexibility by matching the output signal ranges to the your application. Table 3-2 shows the overall output range and resolution according to the attenuation used.

Table 3-2. Actual Output Range and Resolution of the PCI-4451

Attenuation Linear	Attenuation dB	Range	Resolution ¹
1.0	0 dB	± 10.0 V	305.18 μ V
10	20 dB	± 1.00 V	30.158 μ V
100	40 dB	± 0.100 V	3.0518 μ V
∞	∞ dB	0 V	0 V

¹ The value of 1 LSB of the 16-bit DAC; that is, the voltage increment corresponding to a change of one count in the DAC 16-bit count.

See Appendix A, *Specifications*, for absolute maximum ratings.



Note The PCI-4451 boots in a mode with the outputs disabled *and* infinitely (∞) attenuated. Although these functions appear similar, they are distinct and are implemented to protect your external equipment from startup transients.

- ◆ PCI-4453

This device does not feature any attenuation setting capability and boots in a mode with outputs disabled.

Trigger

In addition to supporting internal software triggering and external digital triggering to initiate a data acquisition sequence, the PCI-445X also supports analog level triggering. You can configure the trigger circuit to monitor any one of the analog input channels to generate the level trigger. Choosing an input channel as the level trigger channel does not influence the input channel capabilities. The level trigger circuit compares the full 16 bits of the programmed trigger level with the digitized 16-bit sample. The trigger-level range is identical to the analog input voltage range. The trigger-level resolution is the same as the resolution for a given input range. Refer to Table 3-1 for more information.

The trigger circuit generates an internal digital trigger based on the input signal and the user-defined trigger levels. Any of the timing sections of the DAQ-STC can use this level trigger, including the analog input, analog output, RTSI, and general-purpose counter/timer sections. For example, you can configure the analog input section to acquire a given number of samples after the analog input signal crosses a specific threshold.

Due to the nature of delta-sigma converters, the triggering circuits operate on the digital output of the converter. Since the trigger is generated at the output of the converter, triggers can occur only when a sample is actually generated. Placing the triggering circuits on the digital side of the converter does not affect most measurements unless an analog output is generated based on the input trigger. In this case, you account for the inherent delays of the finite impulse response (FIR) filters internal to the delta-sigma converters. The delay through the input converter is 42 sample periods, while the delay through the output converter is 34.6 ± 0.5 sample periods. Note that the input and output sample periods may differ.

During repetitive sampling of a waveform, you might observe jitter due to the uncertainty of where a trigger level falls compared to the actual digitized data. Although this trigger jitter is never greater than one sample period, it can seem quite bad when the sample rate is only twice the

bandwidth of interest. This jitter has no effect on the processing of the data, and you can decrease this jitter by oversampling.

There are five analog level triggering modes available, as shown in Figures 3-4 through 3-8. You can set **lowValue** and **highValue** independently in the software.

In below-low-level triggering mode, shown in Figure 3-4, the trigger is generated when the signal value is less than **lowValue**. **highValue** is unused.

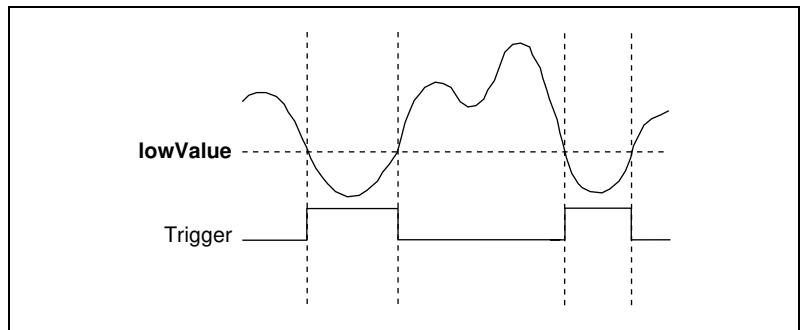

Figure 3-4. Below-Low-Level Triggering Mode

In above-high-level triggering mode, shown in Figure 3-5, the trigger is generated when the signal value is greater than **highValue**. **lowValue** is unused.

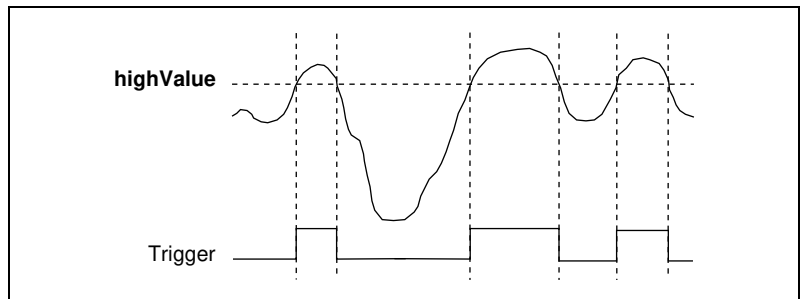

Figure 3-5. Above-High-Level Triggering Mode

In inside-region triggering mode, the trigger is generated when the signal value is between **lowValue** and **highValue**.

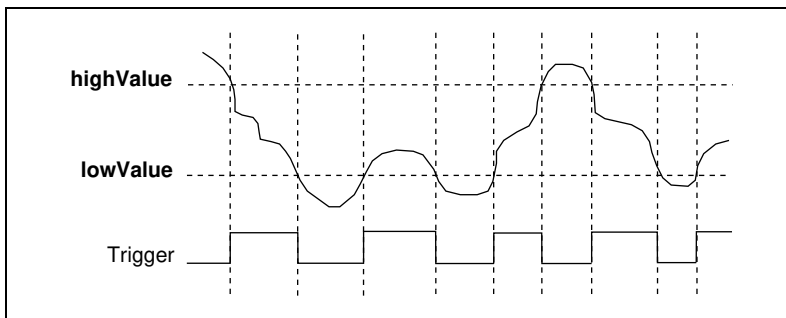

Figure 3-6. Inside-Region Triggering Mode

In high-hysteresis triggering mode, the trigger is generated when the signal value is greater than **highValue**, with the hysteresis specified by **lowValue**.

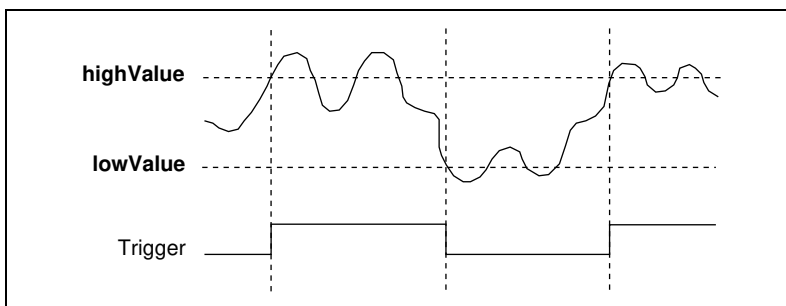

Figure 3-7. High-Hysteresis Triggering Mode

In low-hysteresis triggering mode, the trigger is generated when the signal value is less than **lowValue**, with the hysteresis specified by **highValue**.

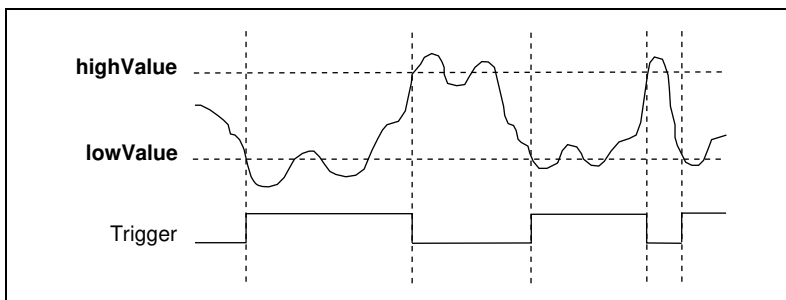

Figure 3-8. Low-Hysteresis Triggering Mode

◆ PCI-4451/4452

With the PCI-4451/4452, you can use digital triggering through the external digital 50-pin connector using any one of the eight available programmable function input (PFI) pins. PFI0/TRIG1 (EXT_TRIG) is the pin dedicated to external digital triggering.

◆ PCI-4453/4454

With the PCI-4453/4454, you can use the SMB connector for dedicated external digital triggering.

◆ PCI-4451/4452/4453/4454

Using digital triggering, you can trigger the PCI-445X from any other National Instruments device that has the RTSI-bus feature and resides on the same PCI bus. You can connect the device through the RTSI bus cable. An external digital trigger can also trigger multiple devices simultaneously by distributing that trigger through the RTSI bus. You can select the polarity of the external digital trigger.

RTSI Triggers

The seven RTSI trigger lines on the RTSI bus provide a very flexible interconnection scheme for any PCI-445X device sharing the RTSI bus. These bidirectional lines can drive any of eight timing signals onto the RTSI bus and can receive any of these timing signals. This signal connection scheme is shown in Figure 3-9.

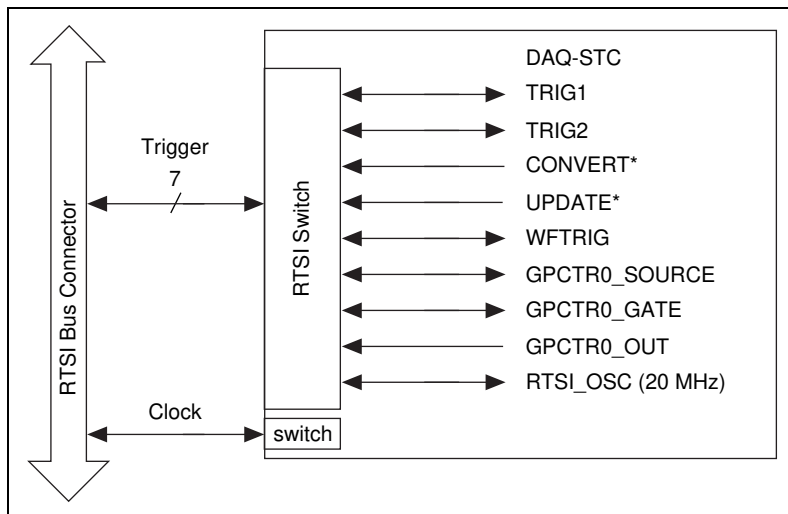

Figure 3-9. RTSI Bus Signal Connection

Refer to the Chapter 4, *Signal Connections*, for a description of the signals shown in Figure 3-9.

Digital I/O (PCI-4451/4452 Only)

The PCI-4451/4452 has eight lines of digital I/O for general-purpose use through the 50-pin connector. You can individually configure each line for either input or output.

The hardware up/down control for general-purpose counters 0 and 1 connect onboard to DIO6 and DIO7, respectively. Thus, you can use DIO6 and DIO7 to control the general-purpose counters. The up/down control signals are input only and do not affect the operation of the DIO lines.



Note At system power-on and reset, the hardware sets both the PFI and DIO lines to high impedance. This means that the device circuitry is not actively driving the output either high or low. For example, DIO0 will be in the high impedance state after power on, and

Table 4-6, *Digital I/O Signal Summary*, shows that there is a 50 k Ω pull-up resistor. This pull-up resistor sets the DIO0 pin to a logic high when the output is in a high-impedance state. Take careful consideration of the power-on state of the system to prevent any damage to external equipment.

Timing Signal Routing

◆ PCI-4451/4452

The DAQ-STC provides a flexible interface for connecting timing signals to other devices or to external circuitry. Your PCI-4451/4452 uses the RTSI bus to interconnect timing signals between devices, and uses the PFI pins on the I/O connector to connect the device to external circuitry. These connections enable the PCI-4451/4452 to both control and be controlled by other devices and circuits.

There are a total of 13 timing signals internal to the DAQ-STC that you can control by an external source. You can also control these timing signals by signals generated internally to the DAQ-STC, and these selections are fully software configurable. Many of these timing signals are also available as outputs on the RTSI pins, as indicated in the *RTSI Triggers* section of this chapter, and on the PFI pins, as indicated in Chapter 4, *Signal Connections*.

◆ PCI-4453/PCI-4454

Your PCI-4453/4454 uses the RTSI bus to interconnect timing signals between devices. The RTSI bus enables the PCI-4453/4454 to both control and be controlled by other devices.

Programmable Function Inputs (PCI-4451/4452 Only)

The 10 PFIs connect to the signal routing multiplexer for each timing signal, and software can select one of the PFIs as the external source for a given timing signal. You can use any of the PFIs as an input for any of the timing signals and multiple timing signals can use the same PFI simultaneously. This flexible routing scheme reduces the need to change physical connections to the I/O connector for different applications. You can also individually enable each of the PFI pins to output a specific internal timing signal. For example, if you need the GPCTR0_SOURCE signal as an output on the I/O connector, software can turn on the output driver for the PFI8/GPCTR0_SOURCE pin.



Note Two of the 10 PFI pins are not available for general-purpose input on the digital connector. You can configure PFI2/CONVERT* and PFI5/UPDATE* as outputs only.

Device and RTSI Clocks

A PCI-445X can use either its internal 20 MHz timebase or a timebase received over the RTSI bus. In addition, if you configure the device to use the internal timebase, you can program the device to drive its internal timebase over the RTSI bus to another device that you program to receive this timebase signal. The default configuration at startup is to use the internal timebase without driving the RTSI bus timebase signal. This timebase is software-selectable. You cannot use these signals for the generating of sample rates or update rates. Refer to the *Selecting Sample/Update Clock Frequency* section for information on sample/update clock generation.

Selecting Sample/Update Clock Frequency

The two analog input channels of the PCI-4451 and the four analog input channels of the PCI-4452 are simultaneously sampled at any software-programmable rate from 5.0 kS/s to 204.8 kS/s in 190.7 μ S/s increments (worst case). The two analog input channels of the PCI-4453 and the four input channels of the PCI-4454 are simultaneously sampled at any software-programmable rate from 5.0 kS/s to 51.2 kS/s in 47.684 μ S/s increments (worst case). The devices use direct digital synthesis (DDS) technology so that you can choose the correct sample rate required for your application. All the input channels acquire data at the same rate. One input channel *cannot* acquire data at a different rate from another input channel.

- ◆ PCI-4451/4453

The two analog output channels of the PCI-4451/4453 are updated simultaneously at any software programmable rate from 1.25 kS/s to 51.2 kS/s in 47.684 μ S/s increments (worst case). The input sample rate and output update rate on the PCI-4451/4453 are synchronized and derived from the same DDS clock. The input and output clocks can differ from each other by a factor of 2 (1, 2, 4, 8, ..., 128) while still maintaining their synchronization as long as the lower bounds for update and sample rate are maintained. All the output channels update data at the same rate. One output channel *cannot* update data at a different rate from another output channel.

◆ PCI-4451/4452/4453/4454

The DDS clock signal and the synchronization start signal are transmitted to other PCI-bus DSA devices through the RTSI bus. The PCI-445X can also receive these signals to synchronize the acquisition or waveform generation with other devices. In a multidevice system, a master device drives the clock and synchronization signal to other slave or receiving devices.

Device Configuration Issues

Selecting a sample rate that is less than two times the frequency of a band of interest can lead you to believe the device is functioning improperly. By undersampling the signal, you might receive what appears to be a DC signal. This situation is due to the sharp antialiasing filters that remove frequency components above the sampling frequency. If you have a situation where this occurs, simply increase the sample rate until it meets the requirements of the *Nyquist Sampling Theorem*. For more information on the filters and aliasing, refer to Chapter 6, *Theory of Analog Operation*.

Unlike other converter technologies, delta-sigma converters must be run continuously and at a minimum clock rate. To operate within guaranteed specifications, the A/D converters must operate at a minimum sample rate of 5.0 kS/s and the D/A converters must operate at a minimum update rate of 1.25 kS/s. This minimum rate is required to keep the internal circuitry of the converters running within specifications. You are responsible for selecting sample and update rates that fall within the specified limits. Failure to do so can greatly affect the specifications.

Signal Connections

This chapter describes how to make input and output connections to your PCI-445X.

The 68-pin analog I/O connector for the PCI-445X connects to the BNC-214X DSA accessories through the SHC68-C68-A1 shielded cable. You can access the analog I/O of the PCI-445X using standard BNC connectors on the BNC-214X.

- ◆ PCI-4451/4452

The digital I/O connector for the PCI-4451/4452 has 50 pins that you can connect to generic 68-pin terminal blocks through the SHC50-68 shielded cable. You can connect the digital I/O signals to the shielded cable through a single 50-pin connector.

- ◆ PCI-4453/4454

This device does not have a digital I/O connector, but instead has an SMB connector for external digital triggering.

I/O Connectors

Table 4-1 describes the pin assignments for the 68-pin analog I/O connector. Table 4-5 describes the 50-pin digital connector on the PCI-4451/4452. A signal description follows the connector pinouts.



Caution Connections that exceed any of the maximum ratings of input or output signals on the PCI-445X can damage the device, the computer, and associated accessories. Maximum input ratings for each signal are given in the Protection column of Tables 4-2, 4-4, and 4-6. National Instruments is *not* liable for any damages resulting from such signal connections.

Analog I/O Connector Signal Descriptions

◆ PCI-4451/4452

Figure 4-1 shows the analog pin connections for the PCI-4451/4452.

-ACH0	1	35	+ACH0
AIGND [†]	2	36	AIGND
-ACH1	3	37	+ACH1
AIGND [†]	4	38	AIGND
-ACH2 ²	5	39	+ACH2 ²
AIGND [†]	6	40	AIGND
-ACH3 ²	7	41	+ACH3 ²
AIGND [†]	8	42	AIGND
NC	9	43	NC
AIGND [†]	10	44	AIGND [†]
NC	11	45	NC
AIGND [†]	12	46	AIGND [†]
NC	13	47	NC
AIGND [†]	14	48	AIGND [†]
NC	15	49	NC
AIGND [†]	16	50	AIGND [†]
NC	17	51	NC
AIGND [†]	18	52	AIGND [†]
NC	19	53	NC
AIGND [†]	20	54	AIGND [†]
NC	21	55	NC
AIGND [†]	22	56	AIGND [†]
NC	23	57	NC
AIGND [†]	24	58	AIGND [†]
-DAC0OUT ¹	25	59	+DAC0OUT ¹
AOGND ^{1†}	26	60	AOGND ¹
-DAC1OUT ¹	27	61	+DAC1OUT ¹
AOGND ^{1†}	28	62	AOGND ¹
NC	29	63	NC
AOGND ^{1†}	30	64	AOGND ^{1†}
NC	31	65	NC
AOGND ^{1†}	32	66	AOGND ^{1†}
+5 V	33	67	+5 V
DGND	34	68	DGND

¹PCI-4451 only
²PCI-4452 only
[†]These AIGND and AOGND pins are not connected in the SHC68-C68-A1 cable.

Figure 4-1. Analog Pin Connections for the PCI-4451/4452

Table 4-1. Analog I/O Connector Pin Assignment for the PCI-4451/4452

Signal Name	Reference	Direction	Description
+ACH<0..3>	AIGND	Input	+Analog Input Channel 0 through 3—The PCI-4451 uses +ACH<0..1> and the PCI-4452 uses +ACH<0..3>.
–ACH<0..3>	AIGND	Input	–Analog Input Channel 0 through 3—The PCI-4451 uses –ACH<0..1> and the PCI-4452 uses –ACH<0..3>.
AIGND	—	—	Analog Input Ground—These pins are the reference point for single-ended measurements in SE configuration and the bias current return point for differential measurements. All three ground references—AIGND, AOGND (PCI-4451 only), and DGND—are connected together on your PCI-4451/4452, but each serves a separate purpose.
+DAC0OUT	–DAC0OUT	Output	+Analog Output Channel 0—This pin supplies the analog non-inverting output channel 0. This pin is available only on the PCI-4451.
–DAC0OUT	+DAC0OUT	Output	–Analog Output Channel 0—This pin supplies the analog inverting output channel 0. This pin is available only on the PCI-4451.
+DAC1OUT	–DAC1OUT	Output	+Analog Output Channel 1—This pin supplies the analog non-inverting output channel 1. This pin is only available on the PCI-4451.
–DAC1OUT	+DAC1OUT	Output	–Analog Output Channel 1—This pin supplies the analog inverting output channel 1. This pin is only available on the PCI-4451.
AOGND	—	—	Analog Output Ground—The analog output voltages are ultimately referenced to this node. All three ground references—AIGND, AOGND (PCI-4451 only), and DGND—are connected together on your PCI-4451/4452, but each serves a separate purpose.
+5 V	DGND	Output	+5 VDC Source—These pins are fused for up to 1 A and supply power to the DSA signal conditioning accessories. The fuse is self resetting.
DGND	—	—	Digital Ground—This pin supplies the reference for the +5 VDC supply. All three ground references—AIGND, AOGND (PCI-4451 only), and DGND—are connected together on your PCI-4451/4452, but each serves a separate purpose.

Table 4-2. Analog I/O Signal Summary for the PCI-4451/4452

Signal Name	Signal Type and Direction	Impedance Input/ Output	Protection (Volts) On/Off	Source (mA at V)	Sink (mA at V)	Rise Time (ns)	Bias
+ACH<0..3>	AI	1 M Ω in parallel with 50 pF to AIGND	± 42.4 V/ ± 42.4 V [†]	—	—	—	± 100 pA
-ACH<0..3>	AI	1 M Ω in parallel with 50 pF to AIGND	± 42.4 V/ ± 42.4 V [†]	—	—	—	± 100 pA
AIGND	AI	—	—	—	—	—	—
+DAC0OUT	AO	22 Ω to -DAC0OUT, 4.55 k Ω to AOGND	Short-circuit to -DAC0OUT, ground	16.7 mA at 10 V	—	—	—
-DAC0OUT	AO	22 Ω to +DAC0OUT, 4.55 k Ω to AOGND	Short-circuit to +DAC0OUT, ground	16.7 mA at 10 V	—	—	—
+DAC1OUT	AO	22 Ω to -DAC1OUT, 4.55 k Ω to AOGND	Short-circuit to -DAC1OUT, ground	16.7 mA at 10 V	—	—	—
-DAC1OUT	AO	22 Ω to +DAC1OUT, 4.55 k Ω to AOGND	Short-circuit to +DAC1OUT, ground	16.7 mA at 10 V	—	—	—
AOGND	AO	—	—	—	—	—	—
DGND	DIO	—	—	—	—	—	—
+5 V	DO	0.7 Ω	Short-circuit to ground	1 A	—	—	—
AI = Analog Input AO = Analog Output DIO = Digital Input/Output DO = Digital Output							
[†] ± 400 V/ ± 400 V guaranteed by design, but not tested or certified to operate beyond ± 42.4 V							

◆ PCI-4453/4454

Figure 4-2 shows the analog pin connections for the PCI-4453/4454.

AI_SHLD0	1	35	+ACH0
CGND [†]	2	36	CGND
AI_SHLD1	3	37	+ACH1
CGND [†]	4	38	CGND
AI_SHLD2 ²	5	39	+ACH2 ²
CGND [†]	6	40	CGND
AI_SHLD3 ²	7	41	+ACH3 ²
CGND [†]	8	42	CGND
NC	9	43	NC
CGND [†]	10	44	CGND [†]
NC	11	45	NC
CGND [†]	12	46	CGND [†]
NC	13	47	NC
CGND [†]	14	48	CGND [†]
NC	15	49	NC
CGND [†]	16	50	CGND [†]
NC	17	51	NC
CGND [†]	18	52	CGND [†]
NC	19	53	NC
CGND [†]	20	54	CGND [†]
NC	21	55	NC
CGND [†]	22	56	CGND [†]
NC	23	57	NC
CGND [†]	24	58	CGND [†]
AO_SHLD0 ¹	25	59	+DAC0OUT ¹
CGND [†]	26	60	CGND
AO_SHLD1 ¹	27	61	+DAC1OUT ¹
CGND [†]	28	62	CGND
NC	29	63	NC
CGND [†]	30	64	CGND [†]
NC	31	65	NC
CGND [†]	32	66	CGND [†]
+5 V	33	67	+5 V
DGND	34	68	DGND

¹PCI-4453 only
²PCI-4454 only
[†]These CGND pins are not connected in the SHC68-C68-A1 cable.

Figure 4-2. Analog Pin Connections for the PCI-4453/4454

Table 4-3. Analog I/O Connector Pin Assignment for the PCI-4453/4454

Signal Name	Reference	Direction	Description
+ACH<0..3>	AIGND	Input	+Analog Input Channel 0 through 3—The PCI-4453 uses +ACH<0..1> and the PCI-4454 uses +ACH<0..3>. Analog Input Ground (AIGND) is the reference point for single-ended measurements.
AI_SHLD <0..3>	—	—	Analog input shield—Each of these pins is tethered to AIGND through a common-mode choke.
CGND	—	—	Chassis Ground—These pins are connected to the chassis ground of your computer through the metal mounting bracket of the PCI-4453/4454. All ground references—AIGND, AOGND, CGND, and DGND—are connected together on your PCI-4453/4454, but each serves a separate purpose.
+DAC0OUT	AOGND	Output	+Analog Output Channel 0—This pin supplies the analog non-inverting output channel 0. This pin is available only on the PCI-4453. Analog Output Ground (AOGND) is the reference point for the analog output voltage.
+DAC1OUT	AOGND	Output	+Analog Output Channel 1—This pin supplies the analog non-inverting output channel 1. This pin is only available on the PCI-4453. Analog Output Ground (AOGND) is the reference point for the analog output voltage.
AO_SHLD <0..1>	—	—	Analog output shield—Each of these pins is tethered to AOGND through a common-mode choke.
+5 V	DGND	Output	+5 VDC Source—These pins are fused for up to 1 A and supply power to the DSA signal conditioning accessories. The fuse is self resetting.
DGND	—	—	Digital Ground—This pin supplies the reference for the +5 VDC supply. All ground references—AIGND, AOGND, CGND, and DGND—are connected together on your PCI-4453/4454, but each serves a separate purpose.

Table 4-4. Analog I/O Signal Summary for the PCI-4453/4454

Signal Name	Signal Type and Direction	Impedance Input/ Output	Protection (Volts) On/Off	Source (mA at V)	Sink (mA at V)	Rise Time (ns)	Bias
+ACH<0..3>	AI	1 M Ω in parallel with 50 pF to AIGND	± 42.4 V/ ± 42.4 V [†]	—	—	—	± 100 pA
AO_SHLD <0..3>	—	—	—	—	—	—	—
CGND	—	—	—	—	—	—	—
+DAC0OUT	AO	22 Ω to AOGND	Short-circuit to ground	16.7 mA at 10 V	—	—	—
+DAC1OUT	AO	22 Ω to AOGND	Short-circuit to ground	16.7 mA at 10 V	—	—	—
AO_SHLD <0..1>	—	—	—	—	—	—	—
DGND	DIO	—	—	—	—	—	—
+5 V	DO	0.7 Ω	Short-circuit to ground	1 A	—	—	—
AI = Analog Input AO = Analog Output DIO = Digital Input/Output DO = Digital Output [†] ± 400 V/ ± 400 V guaranteed by design, but not tested or certified to operate beyond ± 42.4 V							

Digital I/O Connector Signal Descriptions

◆ PCI-4451/4452

Figure 4-3 shows the digital pin connections for the PCI-4451/4452.

FREQ_OUT	1	26	DGND
GPCTR0_OUT	2	27	PFI9/GPCTR0_GATE
PFI8/GPCTR0_SOURCE	3	28	DGND
PFI6/WFTRIG	4	29	UPDATE*
PFI7	5	30	DGND
GPCTR1_OUT	6	31	PFI4/GPCTR1_GATE
PFI3/GPCTR1_SOURCE	7	32	DGND
PFI1/TRIG2 (PRETRIG)	8	33	PFI0/TRIG1(EXT_TRIG)
CONVERT*	9	34	DGND
DIO7	10	35	RESERVED1
DIO6	11	36	DGND
DIO0	12	37	DIO1
DIO2	13	38	DGND
DIO4	14	39	EXTSTROBE*
DIO3	15	40	DGND
+5 V	16	41	DIO5
+5 V	17	42	NC
+5 V	18	43	+5 V
NC	19	44	DGND
NC	20	45	NC
NC	21	46	DGND
NC	22	47	NC
NC	23	48	DGND
NC	24	49	NC
NC	25	50	DGND

Figure 4-3. Digital Pin Connections

Refer to Appendix B, *Pin Connections*, for the digital pin connections of the 68-pin connector.

Table 4-5. Digital I/O Connector Pin Assignment

Signal Name	Reference	Direction	Description
DIO<0..7>	DGND	Input or Output	Digital I/O channels 0 through 7—Channels 6 and 7 can control the up/down signal of general-purpose counters 0 and 1, respectively.
DGND	—	—	Digital Ground—This pin supplies the reference for the digital signals at the I/O connector as well as the +5 VDC supply.
+5 V	DGND	Output	+5 VDC Source—These pins are fused for up to 1 A of +5 V supply. The fuse is self-resetting.
RESERVED1	DGND	Output	RESERVED—This pin is reserved. This signal is always high.
EXTSTROBE*	DGND	Output	External Strobe—Software can toggle this signal to latch signals or trigger events on external devices.
PFI0/TRIG1 (EXT_TRIG)	DGND	Input Output	TRIG1—As an input, this is a source for the data acquisition trigger. As an output, this signal can drive external applications to indicate that a trigger on the device has occurred. TRIG1 is the start acquisition signal. In LabVIEW, referred to as AI Start Trigger for both input and output.
PFI1/TRIG2 (PRETRIG)	DGND	Input Output	PFI1/TRIG2 (PRETRIG)—As an input, this is one of the PFIs. As an output, this is the TRIG2 signal. In pretrigger applications, a low-to-high transition indicates the initiation of the posttrigger conversions. TRIG2 is not used in posttrigger applications. In LabVIEW, referred to as AI Stop Trigger for both input and output.
CONVERT*	DGND	Output	A high-to-low edge on CONVERT* indicates that an A/D conversion is occurring. In LabVIEW, referred to as AI Convert.
PFI3/GPCTR1_SOURCE	DGND	Input Output	PFI3/Counter 1 Source—As an input, this is one of the PFIs. As an output, this is the GPCTR1_SOURCE signal. This signal reflects the actual source connected to the general-purpose counter 1.

Table 4-5. Digital I/O Connector Pin Assignment (Continued)

Signal Name	Reference	Direction	Description
PFI4/GPCTR1_GATE	DGND	Input Output	PFI4/Counter 1 Gate—As an input, this is one of the PFIs. As an output, this is the GPCTR1_GATE signal. This signal reflects the actual GATE signal connected to the general-purpose counter 1.
UPDATE*	DGND	Output	A high-to-low edge on UPDATE* indicates that a D/A conversion is occurring. In LabVIEW, referred to as AO Update.
GPCTR1_OUT	DGND	Output	General-Purpose Counter 1 Output
PFI6/WFTRIG	DGND	Input Output	PFI6/Waveform Trigger—As an input, this is one of the PFIs. As an output, this is the WFTRIG signal. In timed analog output sequences, a low-to-high transition indicates the initiation of the waveform generation. In LabVIEW, referred to as AO Start Trigger for both input and output.
PFI7	DGND	Input	PFI7—This is one of the PFIs.
PFI8/GPCTR0_SOURCE	DGND	Input Output	PFI8/Counter 0 Source—As an input, this is one of the PFIs. As an output, this is the GPCTR0_SOURCE signal. This signal reflects the actual source connected to the general-purpose counter 0.
PFI9/GPCTR0_GATE	DGND	Input Output	PFI9/Counter 0 Gate—As an input, this is one of the PFIs. As an output, this is the GPCTR0_GATE signal. This signal reflects the actual GATE signal connected to the general-purpose counter 0.
GPCTR0_OUT	DGND	Output	General-Purpose Counter 0 Output
FREQ_OUT	DGND	Output	Frequency Output—This output is from the frequency generator output.

Table 4-6. Digital I/O Signal Summary

Signal Name	Signal Type and Direction	Impedance Input/ Output	Protection (Volts) On/Off	Source (mA at V)	Sink (mA at V)	Rise Time (ns)	Bias
DGND	DIO	—	—	—	—	—	—
+5 V	DIO	0.15 Ω	Short-circuit to ground	1A	—	—	—
DIO<0..7>	DIO	—	$V_{cc} +0.5$	13 at ($V_{cc} -0.4$)	24 at 0.4	1.1	50 k Ω pu
RESERVED1	DO	—	—	—	—	—	50 k Ω pu
EXTSTROBE*	DO	—	—	3.5 at ($V_{cc} -0.4$)	5 at 0.4	1.5	50 k Ω pu
PFI0/TRIG1 (EXT_TRIG)	DIO	—	$V_{cc} +0.5$	3.5 at ($V_{cc} -0.4$)	5 at 0.4	1.5	50 k Ω pu
PFI1/TRIG2 (PRETRIG)	DIO	—	$V_{cc} +0.5$	3.5 at ($V_{cc} -0.4$)	5 at 0.4	1.5	50 k Ω pu
CONVERT*	DO	—	—	3.5 at ($V_{cc} -0.4$)	5 at 0.4	1.5	50 k Ω pu
PFI3/GPCTR1_SOURCE	DIO	—	$V_{cc} +0.5$	3.5 at ($V_{cc} -0.4$)	5 at 0.4	1.5	50 k Ω pu
PFI4/GPCTR1_GATE	DIO	—	$V_{cc} +0.5$	3.5 at ($V_{cc} -0.4$)	5 at 0.4	1.5	50 k Ω pu
GPCTR1_OUT	DO	—	—	3.5 at ($V_{cc} -0.4$)	5 at 0.4	1.5	50 k Ω pu
UPDATE*	DO	—	—	3.5 at ($V_{cc} -0.4$)	5 at 0.4	1.5	50 k Ω pu
PFI6/WFTRIG	DIO	—	$V_{cc} +0.5$	3.5 at ($V_{cc} -0.4$)	5 at 0.4	1.5	50 k Ω pu
PFI7	DI	—	$V_{cc} +0.5$	—	—	—	50 k Ω pu
PFI8/GPCTR0_SOURCE	DIO	—	$V_{cc} +0.5$	3.5 at ($V_{cc} -0.4$)	5 at 0.4	1.5	50 k Ω pu
PFI9/GPCTR0_GATE	DIO	—	$V_{cc} +0.5$	3.5 at ($V_{cc} -0.4$)	5 at 0.4	1.5	50 k Ω pu
GPCTR0_OUT	DO	—	—	3.5 at ($V_{cc} -0.4$)	5 at 0.4	1.5	50 k Ω pu
FREQ_OUT	DO	—	—	3.5 at ($V_{cc} -0.4$)	5 at 0.4	1.5	50 k Ω pu

DI = Digital Input DIO = Digital Input/Output DO = Digital Output pu = pullup
Note: The tolerance on the 50 k Ω pullup and pulldown resistors is very large. Actual value may range from 17 to 100 k Ω .

Analog Input Signal Connections

◆ PCI-4451/4452

The analog input signals for the PCI-4451/4452 are $+ACH<0..3>$, $-ACH<0..3>$, and AIGND. The $\pm ACH<0..1>$ signals are tied to the two analog input channels of your PCI-4451; the $\pm ACH<0..3>$ are tied to the four analog input channels of your PCI-4452.



Caution Exceeding the differential and common-mode input ranges distorts your input signals.

AIGND is an analog input common signal that connects directly to the ground system on the PCI-4451/4452. You can use this signal for a general analog ground tie point to your PCI-4451/4452 if necessary, but connecting AIGND to other earth-connected grounds is not recommended. AIGND is not directly available if you are using a BNC-2140 accessory.

Figure 4-4 shows a diagram of the analog input stage of your PCI-4451/4452.

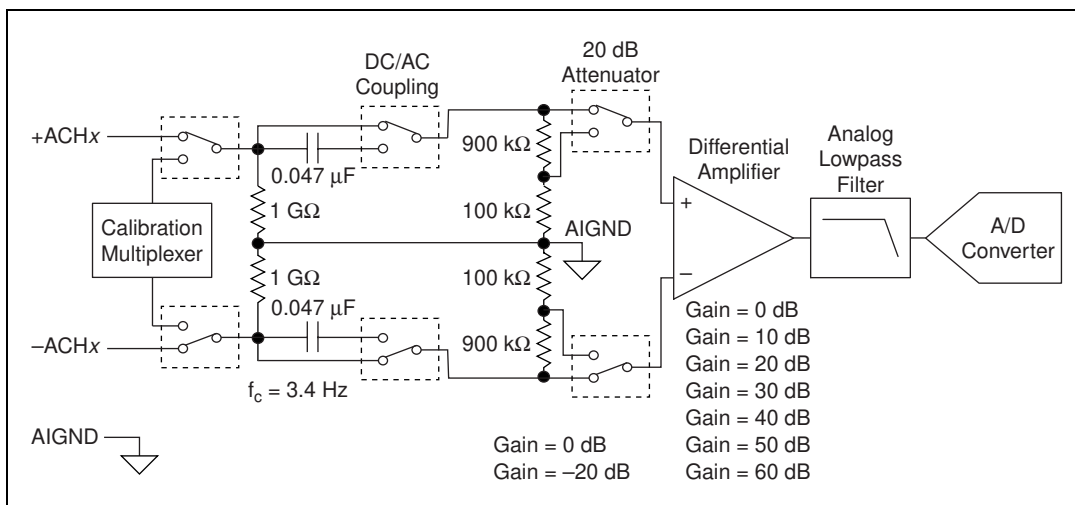

Figure 4-4. Analog Input Stage of the PCI-4451/4452

The analog input stage applies gain and common-mode voltage rejection and presents high input impedance to the analog input signals connected to your PCI-4451/4452. Signals are routed directly to the positive and negative inputs of the analog input stage on the device. The analog input

stage converts two input signals to a voltage that is the difference between the two input signals multiplied by the gain setting of the amplifier. Your PCI-4451/4452 A/D converter (ADC) measures this voltage when it performs A/D conversions.

Connection of analog input signals to your PCI-4451/4452 depends on the configuration of the input signal sources. For most signals, you use a DIFF configuration and simply connect the signal to +ACH x (where x is the PCI-4451/4452 channel) and the signal ground (or signal minus, as appropriate) to -ACH x . However, if a signal has a high output impedance (greater than 1 k Ω) and is floating, you can use an SE configuration and tether the signal minus to AIGND to reduce common-mode interference. You can make the DIFF and SE connections through the BNC-2140 accessory.

◆ PCI-4453/4454

Figure 4-5 shows a diagram of your PCI-4453/4454 analog input stage.

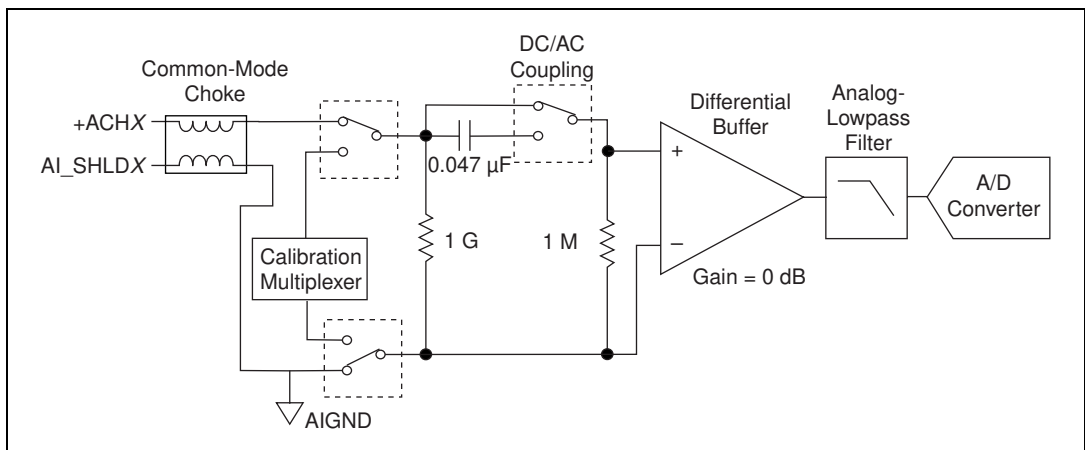

Figure 4-5. Analog Input Stage of the PCI-4453/4454

The analog input stage presents high input impedance to the analog input signals connected to your PCI-4453/4454. Signals are routed to the positive inputs of the analog input stage and their returns to AIGND through a common-mode choke. Your PCI-4453/4454 A/D converters measure these signals when they perform A/D conversions.

Types of Signal Sources

Before configuring the input channels and making signal connections, determine whether the signal sources are floating or ground-referenced. The following sections describe these two types of signals.

Floating Signal Sources

A floating signal source does not connect in any way to the building ground system, but instead has an isolated ground-reference point. Some examples of floating signal sources are outputs of transformers, thermocouples, battery-powered devices, optical isolator outputs, and isolation amplifiers. An instrument or device that has an isolated output is a floating signal source.

Ground-Referenced Signal Sources

A ground-referenced signal source connects in some way to the building system ground and is, therefore, already connected to a common ground point with respect to the PCI-445X, assuming that you plug the computer into the same power system. Nonisolated outputs of instruments and devices that plug into the building power system fall into this category.

The difference in ground potential between two instruments connected to the same building power system is typically between 1 and 100 mV, but can be much higher if power distribution circuits are not properly connected. For this reason, National Instruments does not recommend connecting AIGND or AOGND to the source signal ground system, since the difference between the grounds can induce currents in the PCI-445X ground system.

Analog Output Signal Connections

◆ PCI-4451

The analog output signals for the PCI-4451 are +DAC0OUT, –DAC0OUT, +DAC1OUT, –DAC1OUT, and AOGND. +DAC0OUT and –DAC0OUT are the plus and minus voltage output signals for analog output channel 0. +DAC1OUT and –DAC1OUT are the plus and minus voltage output signal for analog output channel 1.

AOGND is a ground-reference signal for both analog output channels. It is connected directly to the ground system on the PCI-4451. You can use this signal for a general analog ground tie point to your PCI-4451 if necessary,

but connecting AOGND to other earth-connected grounds is not recommended. AOGND is not directly available if you are using the BNC-2140 accessory.

The PCI-4451 has two identical analog output channels. One analog output channel is illustrated in Figure 4-6.

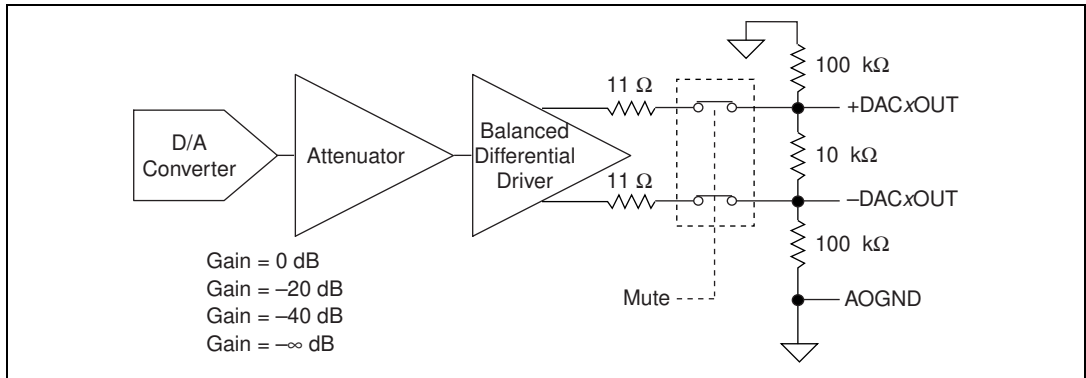

Figure 4-6. Analog Output Channel Block Diagram for the PCI-4451

The analog output stage is differential and balanced. Each output signal consists of a plus connection, a minus connection, and a ground (AOGND) connection. The actual output signal is the *difference* between the plus and minus connections. The pair is *balanced*, meaning that if the impedances from each of the pair to AOGND is the same (or infinite), then the voltage at the plus and minus terminals are equal but opposite, so that their difference is the desired signal and their sum (or average) is zero. If impedances from each of the pair to AOGND is not the same, the connection is unbalanced, but the difference between the plus and minus terminals is still equal to the desired signal. If the minus side is grounded, the plus voltage is equal to the signal. Conversely, if the plus side is grounded, the minus voltage is equal to the negative of the signal. In all cases, the difference is equal to the signal.

Connection of analog output signals from your PCI-4451 device depends on the configuration of the devices receiving the signals. For most signals, you use a DIFF configuration and simply connect +DACxOUT (where x is the PCI-4451 channel) to the signal and -DACxOUT to the signal ground (or signal minus, as appropriate). When driving some floating devices, however, you may sometimes find it helpful to use the SE configuration and connect the floating ground system of the device to AOGND to reduce common-mode noise coupled from an interfering source to the device. You can make DIFF and SE connections through the BNC-2140 accessory.

◆ PCI-4453

The analog output signals for the PCI-4453 are +DAC0OUT, AO_SHLD0, +DAC1OUT, and AO_SHLD1. +DAC0OUT and AO_SHLD0 are the voltage output signal and its return for analog output channel 0. +DAC1OUT and AO_SHLD1 are the voltage output signal and its return for analog output channel 1.

AO_SHLD0 and AO_SHLD1 are connected to AOGND through a common-mode choke. AOGND is not directly available at the analog connector. Instead, you can use CGND as a general ground tie point to your PCI-4453 if necessary, but connecting CGND to other earth-connected grounds is not recommended. Remember to connect AO_SHLDx to your ground tie point.

The PCI-4453 has two identical analog output channels. One analog output channel is illustrated in Figure 4-7.

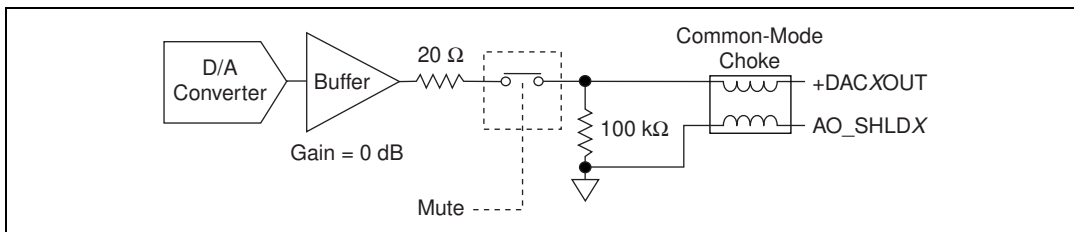

Figure 4-7. Analog Output Channel Block Diagram for the PCI-4453

The analog output stage is single-ended only. This means that the devices or loads receiving signals should not have their signal returns connected to any earth-connected grounds external to the PCI-4453.

Analog Power Connections

Two pins on the analog I/O connector supply +5 V (+4.65 to +5.25 VDC at 1.0 A) from the computer power supply through a self-resetting fuse. The fuse resets automatically within a few seconds after an overcurrent condition is removed. These pins are referenced to DGND, and you can use them to power external analog accessories like the BNC-214X.



Caution Do *not* connect these +5 V power pins directly to analog ground, digital ground, or to any other voltage source on the PCI-445X or any other device. Doing so can damage the PCI-445X device and the computer. National Instruments is *not* liable for damages resulting from such a connection.

Digital I/O Signal Connections (PCI-4451/4452 Only)

The digital I/O signals are DIO<0..7> and DGND. DIO<0..7> are the signals making up the DIO port. DGND is the ground-reference signal for the DIO port. You can program all lines individually to be inputs or outputs.

Figure 4-8 shows signal connections for three typical digital I/O applications.

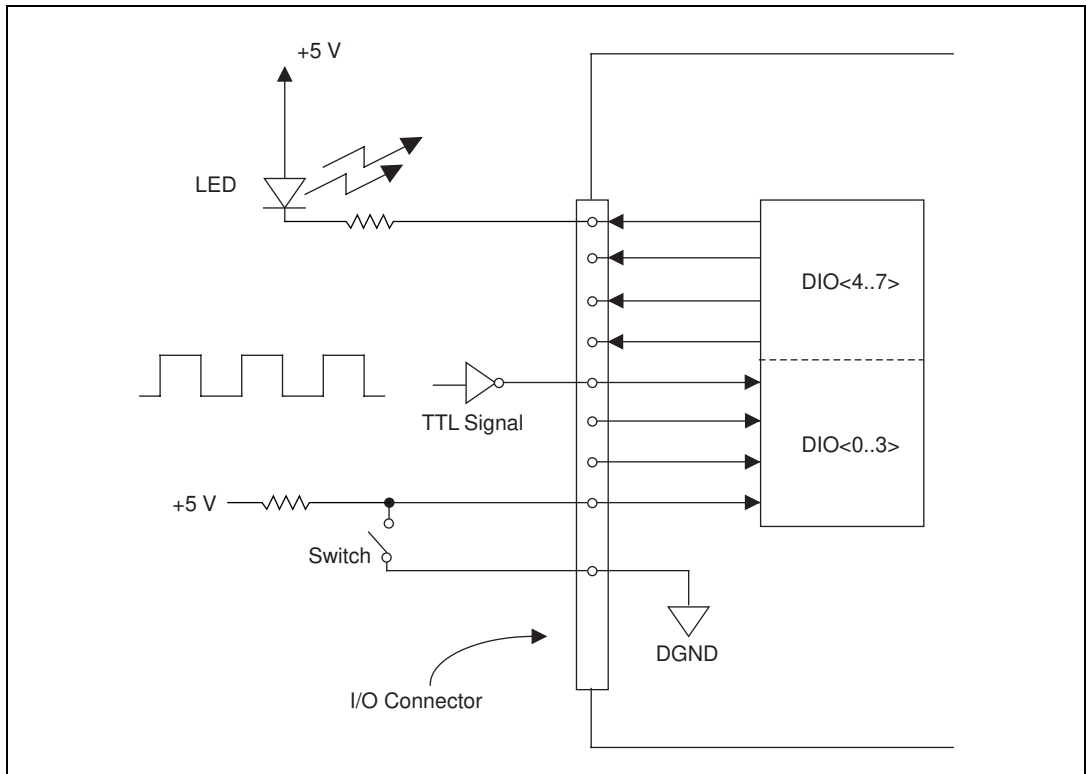

Figure 4-8. Digital I/O Connections

Figure 4-8 shows DIO<0..3> configured for digital input and DIO<4..7> configured for digital output. Digital input applications include receiving TTL signals and sensing external device states such as the state of the switch shown in Figure 4-8. Digital output applications include sending TTL signals and driving external devices such as the LED shown in Figure 4-8.

Digital Power Connections (PCI-4451/4452 Only)

Four pins on the digital I/O connector supply +5 V (+4.65 to +5.25 VDC at 1 A) from the computer power supply through a self-resetting fuse. The fuse resets automatically within a few seconds after an overcurrent condition is removed. These pins are referenced to DGND and you can use them to power external digital circuitry.



Caution Do *not* under any circumstances connect these +5 V power pins directly to analog ground, digital ground, or to any other voltage source on the PCI-4451/4452 or any other device. Doing so can damage the PCI-4451/4452 device and the computer. National Instruments is *not* liable for damages resulting from such a connection.

Timing Connections

- ◆ PCI-4451/4452

All external control over the timing of your PCI-4451/4452 is routed through the 10 programmable function inputs labeled PFI0 through PFI9 (excluding PFI2 and PFI5) and through the RTSI bus. See Figure 3-9, *RTSI Bus Signal Connection*, for a list of these signals. These signals are explained in detail in the next section, *Programmable Function Input Connections (PCI-4451/4452 Only)*. Most of these PFIs are bidirectional. As outputs, they are not programmable and reflect the state of acquisition, waveform generation, and general-purpose timing signals. As inputs, the PFI signals are programmable and can control any acquisition, waveform generation, and general-purpose timing signals.

- ◆ PCI-4453/4454

Since the PCI-4453/4454 has no digital connector, timing signals can only be routed to the RTSI bus. See Figure 3-9, *RTSI Bus Signal Connection*.

- ◆ PCI-4451/4452/4453/4454

The acquisition signals are explained in the *Acquisition Timing Connections* section in this chapter. The waveform generation signals are explained in the *Waveform Generation Timing Connections* section in this chapter. The general-purpose timing signals are explained in the *General-Purpose Timing Signal Connections* section in this chapter.

All digital timing connections are referenced to DGND.

Programmable Function Input Connections (PCI-4451/4452 Only)

You can individually enable each of the PFI pins to output a specific internal timing signal. For example, if you need the GPCTR1_SOURCE signal as an output on the I/O connector, software can turn on the output driver for the PFI3/GPCTR1_SOURCE pin.



Caution Be careful *not* to drive a PFI signal externally when it is configured as an output.

As an input, you can individually configure each PFI for edge or level detection and for polarity selection as well. You can use the polarity selection for any of the timing signals, but your choice of edge or level detection depends on the particular timing signal you are controlling. The detection requirements for each timing signal are listed within the section that discusses that individual signal.

In edge-detection mode, the minimum pulse width required is 10 ns. This applies for both rising-edge and falling-edge polarity settings. There is no maximum pulse-width requirement in edge-detect mode.

In level-detection mode, there are no minimum or maximum pulse-width requirements imposed by the PFIs themselves, but there can be limits imposed by the particular timing signal you are controlling. These requirements are listed in this chapter.

Acquisition Timing Connections

The acquisition timing signals are PFI0/TRIG1, PFI1/TRIG2, CONVERT*, and EXTSTROBE*. EXTSTROBE* is used only on the PCI-4451/4452.

Posttriggered data acquisition allows you to view only data that you acquire after receiving a trigger event. A typical posttriggered acquisition sequence is shown in Figure 4-9.

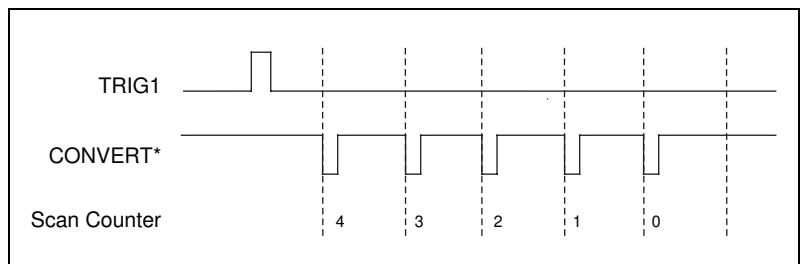

Figure 4-9. Typical Posttriggered Acquisition

Pretriggered data acquisition allows you to view data that you acquire before the trigger of interest in addition to data you acquire after the trigger. Figure 4-10 shows a typical pretriggered acquisition sequence. The description for each signal shown in these figures is included in this chapter.

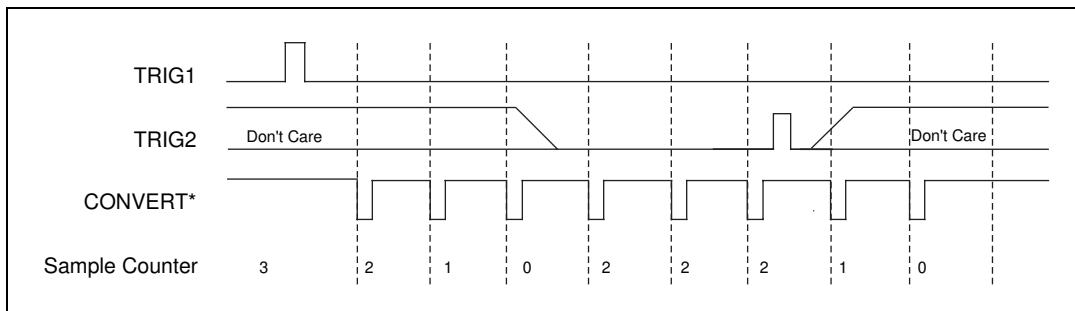

Figure 4-10. Typical Pretriggered Acquisition

PFI0/TRIG1 (EXT_TRIG) Signal

Any PFI pin can receive as an input the PFI0/TRIG1 (EXT_TRIG) signal, which is available as an output on the PFI0/TRIG1 (EXT_TRIG) pin.

Refer to Figures 4-9 and 4-10 for the relationship of PFI0/TRIG1 to the acquisition sequence.

As an input, the PFI0/TRIG1 signal is configured in the edge-detection mode. You can select any PFI pin as the source for PFI0/TRIG1 and configure the polarity selection for either rising or falling edge. The selected edge of the PFI0/TRIG1 signal starts the data acquisition sequence for both posttriggered and pretriggered acquisitions. The PCI-4451/4452 supports analog level triggering on the PFI0/TRIG1 pin. See Chapter 3, [Hardware Overview](#), for more information on analog level triggering.

As an output, the PFI0/TRIG1 signal reflects the action that initiates an acquisition sequence. This is true even if the acquisition is externally triggered by another PFI signal. The output is an active high pulse with a pulse width of 50 to 100 ns. This output is set to high-impedance at startup.

The device also uses the PFI0/TRIG1 signal to initiate pretriggered acquisition operations. In most pretriggered applications, the PFI0/TRIG1 signal is generated by a software trigger. Refer to the [PFI1/TRIG2 \(PRETRIG\) Signal](#) section for a complete description of the use of PFI0/TRIG1 and PFI1/TRIG2 in a pretriggered acquisition operation.

PFI1/TRIG2 (PRETRIG) Signal

Any PFI pin can receive as an input the PFI1/TRIG2 (PRETRIG) signal, which is available as an output on the PFI1/TRIG2 (PRETRIG) pin.

Refer to Figure 4-10 for the relationship of PFI1/TRIG2 to the acquisition sequence.

As an input, the PFI1/TRIG2 signal is configured in edge-detection mode. You can select any PFI pin as the source for PFI1/TRIG2 and configure the polarity selection for either rising or falling edge. The selected edge of the PFI1/TRIG2 signal initiates the posttriggered phase of a pretriggered acquisition sequence. In pretriggered mode, the PFI0/TRIG1 signal initiates the data acquisition. The scan counter indicates the minimum number of scans before PFI1/TRIG2 is recognized. After the scan counter decrements to zero, it is loaded with the number of posttrigger scans to acquire while the acquisition continues. The device ignores the PFI1/TRIG2 signal if it is asserted prior to the scan counter decrementing to zero. After the selected edge of PFI1/TRIG2 is received, the device acquires a fixed number of scans and the acquisition stops. After PFI1/TRIG2 is received, any additional PFI1/TRIG2 signals are ignored until the acquisition is restarted. This mode acquires data both before and after receiving PFI1/TRIG2.

As an output, the PFI1/TRIG2 signal reflects the posttrigger in a pretriggered acquisition sequence. This is true even if the acquisition is externally triggered by another PFI signal. The PFI1/TRIG2 signal is not used in posttriggered data acquisition. The output is an active high pulse with a pulse width of 50 to 100 ns. This output is set to high-impedance at startup.

CONVERT* Signal

The CONVERT* signal is only available as an output on the CONVERT* pin. The CONVERT* signal reflects the end of delta-sigma conversion on the ADC. The output is an active-low pulse with a pulse width of 70 to 100 ns. This output is set to high-impedance at startup.

EXTSTROBE* Signal (PCI-4451/4452 Only)

EXTSTROBE* is an output-only signal that generates either a single pulse or a sequence of eight pulses in the hardware-strobe mode. An external device can use this signal to latch signals or to trigger events. In single-pulse mode, software controls the level of the EXTSTROBE* signal. A 10 μ s and a 1.2 μ s clock is available for generating a sequence

of eight pulses in hardware-strobe mode. Figure 4-11 shows the timing for hardware-strobe mode EXTSTROBE* signal.

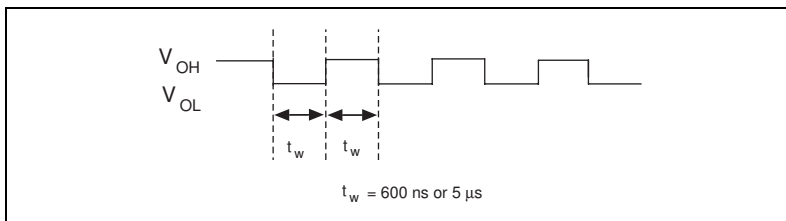

Figure 4-11. EXTSTROBE* Signal Timing

Waveform Generation Timing Connections

The waveform generation timing signals are WFTRIG and UPDATE*.

WFTRIG Signal

Any PFI pin can receive as an input the WFTRIG signal, which is available as an output on the PFI6/WFTRIG pin.

As an input, the WFTRIG signal is configured in the edge-detection mode. You can select any PFI pin as the source for WFTRIG and configure the polarity selection for either rising or falling edge. The selected edge of the WFTRIG signal starts the waveform generation for the DACs.

As an output, the WFTRIG signal reflects the trigger that initiates waveform generation. This is true even if the waveform generation is externally triggered by another PFI signal. The output is an active high pulse with a pulse width of 50 to 100 ns. This output is set to high-impedance at startup.

UPDATE* Signal

The UPDATE* signal is only available as an output on the UPDATE* pin. The UPDATE* signal reflects the end of a delta-sigma conversion on the DACs. The output is an active-low pulse with a pulse width of 70 to 100 ns. This output is set to high-impedance at startup.

General-Purpose Timing Signal Connections

The general-purpose timing signals are GPCTR0_SOURCE, GPCTR0_GATE, GPCTR0_OUT, GPCTR0_UP_DOWN, GPCTR1_SOURCE, GPCTR1_GATE, GPCTR1_OUT, GPCTR1_UP_DOWN, and FREQ_OUT.

GPCTR0_SOURCE Signal

Any PFI pin can receive as an input the GPCTR0_SOURCE signal, which is available as an output on the PFI8/GPCTR0_SOURCE pin.

As an input, the GPCTR0_SOURCE signal is configured in the edge-detection mode. You can select any PFI pin as the source for GPCTR0_SOURCE and configure the polarity selection for either rising or falling edge.

As an output, the GPCTR0_SOURCE signal reflects the actual clock connected to general-purpose counter 0. This is true even if another PFI signal is receiving the source clock input. This output is set to high-impedance at startup.

Figure 4-12 shows the timing requirements for the GPCTR0_SOURCE signal.

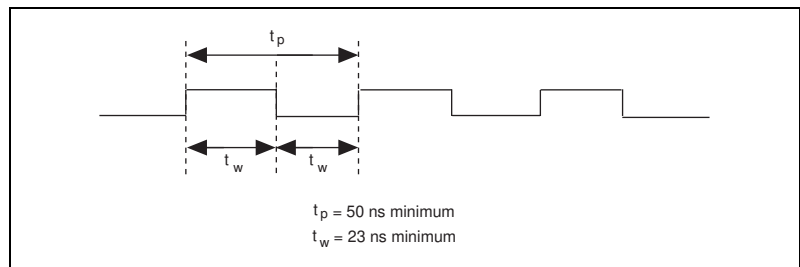

Figure 4-12. GPCTR0_SOURCE Signal Timing

The maximum allowed frequency is 20 MHz, with a minimum pulse width of 23 ns high or low. There is no minimum frequency limitation.

The 20 MHz or 100 kHz timebase normally generates the GPCTR0_SOURCE signal unless you select an external source.

GPCTR0_GATE Signal

Any PFI pin can receive as an input the GPCTR0_GATE signal, which is available as an output on the PFI9/GPCTR0_GATE pin.

As an input, the GPCTR0_GATE signal is configured in the edge-detection mode. You can select any PFI pin as the source for GPCTR0_GATE and configure the polarity selection for either rising or falling edge. You can use the GATE signal in a variety of different applications to perform actions such as starting and stopping the counter, generating interrupts, saving the counter contents, and so on.

As an output, the GPCTR0_GATE signal reflects the actual GATE signal connected to general-purpose counter 0. This is true even if the GATE is externally generated by another PFI signal. This output is set to high-impedance at startup.

GPCTR0_OUT Signal

This signal is available only as an output on the GPCTR0_OUT pin. The GPCTR0_OUT signal reflects the terminal count (TC) of general-purpose counter 0. You have two software-selectable output options—pulse on TC and toggle output polarity on TC. The output polarity is software selectable for both options. This output is set to high-impedance at startup.

Figure 4-13 shows the timing of the GPCTR0_OUT signal.

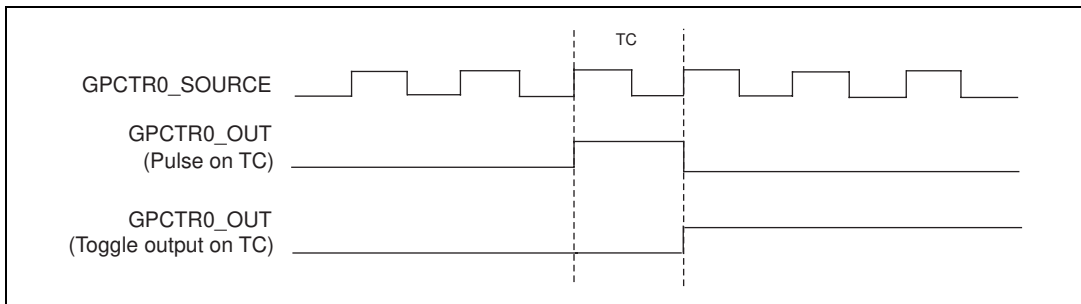

Figure 4-13. GPCTR0_OUT Signal Timing

GPCTR0_UP_DOWN Signal (PCI-4451/4452 Only)

You can input this signal on the DIO6 pin. It is not available as an output on the I/O connector. The general-purpose counter 0 counts down when this pin is at a logic low and counts up when it is at a logic high. You can disable this input so that software can control the up-down functionality and leave the DIO6 pin free for general use.

GPCTR1_SOURCE Signal (PCI-4451/4452 Only)

Any PFI pin can receive as an input the GPCTR1_SOURCE signal, which is available as an output on the PFI3/GPCTR1_SOURCE pin.

As an input, the GPCTR1_SOURCE signal is configured in edge-detection mode. You can select any PFI pin as the source for GPCTR1_SOURCE and configure the polarity selection for either rising or falling edge.

As an output, the GPCTR1_SOURCE monitors the actual clock connected to general-purpose counter 1. This is true even if the source clock is externally generated by another PFI signal. This output is set to high-impedance at startup.

Figure 4-14 shows the timing requirements for the GPCTR1_SOURCE signal.

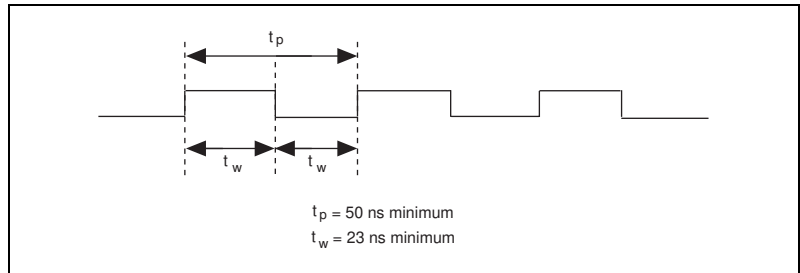

Figure 4-14. GPCTR1_SOURCE Signal Timing

The maximum allowed frequency is 20 MHz, with a minimum pulse width of 23 ns high or low. There is no minimum frequency limitation.

The 20 MHz or 100 kHz timebase normally generates the GPCTR1_SOURCE unless you select some external source.

GPCTR1_GATE Signal (PCI-4451/4452 Only)

Any PFI pin can receive as an input the GPCTR1_GATE signal, which is available as an output on the PFI4/GPCTR1_GATE pin.

As an input, the GPCTR1_GATE signal is configured in edge-detection mode. You can select any PFI pin as the source for GPCTR1_GATE and configure the polarity selection for either rising or falling edge. You can use the GATE signal in a variety of different applications to perform such actions as starting and stopping the counter, generating interrupts, saving the counter contents, and so on.

As an output, the GPCTR1_GATE signal monitors the actual GATE signal connected to general-purpose counter 1. This is true even if the GATE is externally generated by another PFI signal. This output is set to high-impedance at startup.

GPCTR1_OUT Signal (PCI-4451/4452 Only)

This signal is available only as an output on the GPCTR1_OUT pin. The GPCTR1_OUT signal monitors the TC device general-purpose counter 1. You have two software-selectable output options—pulse on TC and toggle output polarity on TC. The output polarity is software selectable for both options. This output is set to high-impedance at startup. Figure 4-15 shows the timing requirements for the GPCTR1_OUT signal.

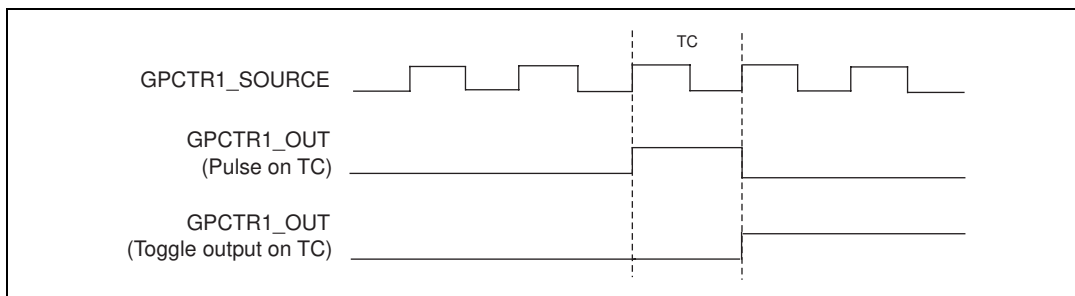

Figure 4-15. GPCTR1_OUT Signal Timing

GPCTR1_UP_DOWN Signal (PCI-4451/4452 Only)

This signal can be received as an input on the DIO7 pin and is not available as an output on the I/O connector. General-purpose counter 1 counts down when this pin is at a logic low and counts up at a logic high. You can disable this input so that software can control the up-down functionality and leave the DIO7 pin free for general use. Figure 4-16 shows the timing requirements for the GATE and SOURCE input signals and the timing specifications for the OUT output signals of your PCI-4451/4452.

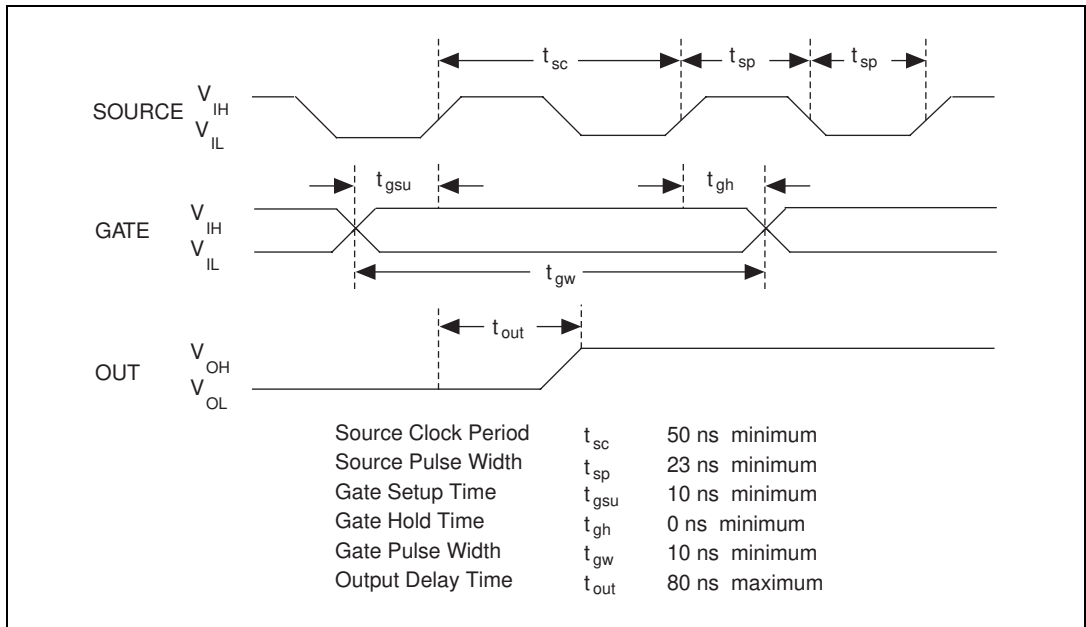

Figure 4-16. GPCTR Timing Summary

The GATE and OUT signal transitions shown in Figure 4-16 are referenced to the rising edge of the SOURCE signal. This timing diagram assumes that you programmed the counters to count rising edges. The same timing diagram, but with the SOURCE signal inverted and referenced to the falling edge of the SOURCE signal, would apply when you programmed the counter to count falling edges.

The GATE input timing parameters are referenced to the signal at the SOURCE input or to one of the internally generated signals on your PCI-4451/4452. Figure 4-16 shows the GATE signal referenced to the rising edge of a SOURCE signal. The GATE signal must be valid (either high or low) for at least 10 ns before the rising or falling edge of a SOURCE signal for the GATE to take effect at that SOURCE edge, as shown by t_{gsu} and t_{gh} in Figure 4-16. It is not necessary to hold the GATE signal after the active edge of the SOURCE signal is detected.

If you use an internal timebase clock, you cannot synchronize the GATE signal with the clock. In this case, GATEs applied close to a SOURCE edge take effect either on that SOURCE edge or on the next one. This arrangement results in an uncertainty of one SOURCE clock period with respect to unsynchronized gating sources.

The OUT output timing parameters are referenced to the signal at the SOURCE input or to one of the internally generated clock signals on the PCI-4451/4452. Figure 4-16 shows the OUT signal referenced to the rising edge of a SOURCE signal. Any OUT signal state changes occur within 80 ns after the rising or falling edge of the SOURCE signal.

FREQ_OUT Signal (PCI-4451/4452 Only)

This signal is available only as an output on the FREQ_OUT pin. The PCI-4451/4452 frequency generator outputs the FREQ_OUT pin. The frequency generator is a 4-bit counter that can divide its input clock by the numbers 1 through 16. The input clock of the frequency generator is software-selectable from the internal 10 MHz and 100 kHz timebases. The output polarity is software selectable. This output is set to high-impedance at startup.

Field Wiring Considerations

- Environmental noise can affect the accuracy of measurements made with your PCI-445X if you do not take proper care when running signal wires between signal sources and the device. For more information, refer to National Instruments Application Note 025, *Field Wiring and Noise Considerations for Analog Signals*

The following recommendations apply mainly to analog input signal routing to the device, although they also apply to signal routing in general.

Minimize noise pickup and maximize measurement accuracy by taking the following precautions:

- Route signals to the device carefully. Keep cabling away from noise sources. The most common noise source in a PCI data acquisition system is the video monitor. Separate the monitor from the analog signals as much as possible.
- Separate PCI-445X signal lines from high-current or high-voltage lines. These lines can induce currents in or voltages on the PCI-445X signal lines if they run in parallel paths at a close distance. To reduce the magnetic coupling between lines, separate them by a reasonable distance if they run in parallel, or run the lines at right angles to each other.
- Do *not* run signal lines through conduits that also contain power lines.

- Protect signal lines from magnetic fields caused by electric motors, welding equipment, breakers, or transformers by running them through special metal conduits.

◆ PCI-4451/4452

The following recommendations apply to all analog signal connections to or from your PCI-4451/4452:

- Use differential analog input connections to reject common-mode noise.
- Use individually shielded, twisted-pair wires to connect analog input signals to the device. With this type of wire, the signals attached to the +ACH_x and –ACH_x inputs are twisted together and then covered with a shield. You then connect this shield only at one point to the signal source ground. This kind of connection is required for signals traveling through areas with large magnetic fields or high electromagnetic interference.

The following recommendations apply for all digital signal connections from your PCI-4451/4452:

- The digital output signal integrity is greatly influenced by the length of the cable being driven. Minimize cable lengths and use schmitt-trigger devices to deglitch signals. Further conditioning may be required to create a clean signal.
- Always try to couple a ground with a signal to minimize noise pickup and radiation.

Calibration

This chapter discusses the calibration procedures for your PCI-445X. Your PCI-445X comes with a calibration certificate. The certificate contains a unique tracking number linking your device to the National Instruments corporate databases where the traceability information is stored.

Calibration refers to the process of minimizing measurement and output voltage errors by making small circuit adjustments. On the PCI-445X devices, these adjustments take the form of writing values to onboard calibration DACs (CalDACs). If you are using the NI-DAQ device driver, that software includes calibration functions for performing all of the steps in the calibration process. Some form of device calibration is required for all but the most forgiving applications. If you do not calibrate your device, your signals and measurements could have very large offset and gain errors. The four levels of calibration available are described in this chapter. The first level is the fastest, easiest, and least accurate, whereas the last level is the slowest, most difficult, and most accurate.

Loading Calibration Constants

Your PCI-445X device is factory calibrated at approximately 25 °C to the levels indicated in Appendix A, *Specifications*. Before shipment, the associated calibration constants—the values that were written to the CalDACs to achieve calibration in the factory—are stored in the onboard nonvolatile memory (EEPROM). Because the CalDACs have no memory capability, they do not retain calibration information when the device is unpowered. Loading calibration constants refers to the process of loading the CalDACs with the values stored in the EEPROM. NI-DAQ software determines when this is necessary and does it automatically.

The EEPROM contains a user-modifiable calibration area in addition to the permanent factory calibration area. This means that you can load the CalDACs with values either from the original factory calibration or from a calibration that you subsequently performed.

Self-Calibration

Your PCI-445X can measure and correct almost all of its calibration-related errors without any external signal connections. Your National Instruments software provides a self-calibration method. This self-calibration process, which generally takes less than a minute, is the preferred method of assuring accuracy in your application. Initiate self-calibration to minimize the effects of any offset and gain drifts, particularly those due to temperature variations.

Your PCI-445X has an onboard calibration reference to ensure the accuracy of self-calibration. Its specifications are listed in Appendix A, *Specifications*. The reference voltage is measured at the factory and stored in the EEPROM for subsequent self-calibrations.

Immediately after self-calibration, the only significant residual calibration error could be gain error due to time or temperature drift of the onboard voltage reference. This error is addressed by external calibration, which is discussed in the *External Calibration* section. If you are interested primarily in relative measurements, you can ignore a small amount of gain error, and self-calibration should be sufficient.

If you calibrate your PCI-4451/4452 while it is connected to a BNC-2140 accessory, set each input channel to SE and connect each channel + terminal to a channel – terminal through a BNC shunt. In addition, make sure that ICP® power is turned off on the BNC-2140 to avoid affecting the reference voltage reading. If you calibrate your PCI-4453/4454 while it is connected to the BNC-2142 accessory, connect each + terminal to its shield through a BNC shunt. You can also calibrate your PCI-445X by removing the external cable connected to the BNC-214X accessory.

External Calibration

The onboard calibration reference voltage is stable enough for most applications, but if you are using your device at an extreme temperature or if the onboard reference has not been measured for a year or more, you might want to externally calibrate your device.

External calibration refers to calibrating your device with a known external reference rather than relying on the onboard reference. You can store the results of an external calibration in the user area of the onboard EEPROM. Externally calibrate your device by calling the NI-DAQ calibration function. When you perform an external calibration, be sure to use a very

accurate external DC reference. The reference should be several times more accurate than the device itself. For example, to calibrate the PCI-445X, the external reference should have a DC accuracy better than ± 115 ppm (± 0.001 dB).

Traceable Recalibration

Traceable recalibration is divided into three different areas—factory, on-site and third party. Devices typically require this type of recalibration every year.

If you require factory recalibration, send your PCI-445X back to National Instruments. National Instruments will send the device back to you with a new calibration certificate. Please check with National Instruments for additional information such as cost and delivery times.

If your company has a metrology laboratory, you can recalibrate the PCI-445X at your location (on-site). You can also send out your PCI-445X for recalibration by a third party. Please contact National Instruments for approved third-party calibration service providers.

Calibration documentation and function libraries are available online at www.ni.com

Theory of Analog Operation

This chapter contains a functional overview and explains the operation of each analog functional unit making up the PCI-445X.

Functional Overview

- ◆ PCI-4451/4452

See Figure 3-2, *PCI-4451/4452 Analog Function Block Diagram*, for a general block diagram of the PCI-4451/4452 analog functions.

- ◆ PCI-4453/4454

See Figure 3-3, *PCI-4453/4454 Analog Function Block Diagram*, for a general block diagram of the PCI-4453/4454 analog functions.

Analog Input Circuitry

- ◆ PCI-4451/4452

The PCI-4451 has two identical analog input channels. The PCI-4452 has four identical analog input channels. An analog input channel is illustrated in Figure 4-4, *Analog Input Stage of the PCI-4451/4452*.

These input channels have 16-bit resolution and are simultaneously sampled at software-programmable rates from 5 to 204.8 kS/s in 190.7 μ S/s increments. This flexibility in sample rates makes the device well suited for a wide variety of applications, including audio and vibration analysis.

The differential analog inputs have AC/DC coupling. You can use the programmable gain amplifier stage on the inputs to select gains from -20 to 60 dB in 10 dB increments. The input stage has differential connections, allowing quiet measurement of either single-ended or differential signals.

◆ PCI-4453/4454

The PCI-4453 has two identical analog input channels. The PCI-4454 has four identical analog input channels. An analog input channel is illustrated in Figure 4-5, *Analog Input Stage of the PCI-4453/4454*. These input channels have 16-bit resolution and are simultaneously sampled at software-programmable rates from 5 to 51.2 kS/s in 47.484 μ S/s increments. This flexibility in sample rates makes the device well suited for a wide variety of applications, including audio and vibration analysis. The analog inputs have AC/DC coupling. The input stage has been designed for high performance measurement of single-ended signals.

◆ PCI-4451/4452/4453/4454

The analog inputs have both analog and real-time digital filters implemented in hardware to prevent aliasing. Input signals first pass through lowpass analog filters to attenuate signals with frequency components beyond the range of the ADCs. Then digital antialiasing filters automatically adjust their cutoff frequency to remove frequency components above half the programmed sampling rate. These filters cause a delay of 42 conversion periods between the input analog data and the digitized data.

The 95 dB dynamic range of the PCI-445X is the result of low noise and distortion and makes possible high-accuracy measurements. The device has an amplitude flatness of ± 0.1 dB, and have a maximum total harmonic distortion (THD) specification of -90 dB at 1 kHz and a worst case THD of -80 dB at higher frequencies.

State-of-the-art, 128-times oversampling, delta-sigma modulating ADCs achieve the low noise and low distortion of the PCI-445X. Because these ADCs sample at 128 times the specified sampling rate with 1-bit resolution, they produce nearly perfect linearity. Extremely flat, linear-phase, lowpass digital filters then remove the quantization noise from outside the band of interest, divide the sample rate by 128, and increase the resolution to 16 bits. Using the delta-sigma modulating ADCs, the PCI-445X is immune to the DNL distortion associated with conventional data acquisition devices.

Input Coupling

The PCI-445X has a software programmable switch to individually configure each input channel for AC or DC coupling. If the switch is set for DC, the capacitor is bypassed, and any DC offset present in the source signal passes to the ADC. The DC configuration is preferred because it places one less component in the signal path and thus has higher fidelity. The DC configuration is recommended if the signal source has only small amounts of offset voltage (less than ± 100 mV), or if the DC content of the acquired signal is important.

If the source has a significant amount of unwanted offset (or bias voltage), you must set the switch for AC coupling to take full advantage of the input signal range. Using AC coupling results in a drop in the low-frequency response of the analog input. The -3 dB cutoff frequency is approximately 3.4 Hz, but the -0.01 dB cutoff frequency, for instance, is considerably higher at approximately 70.5 Hz. The input coupling switch can connect the input circuitry to ground instead of to the signal source. This connection is usually made during offset calibration, which is described in Chapter 5, [Calibration](#).

Calibration

The PCI-445X analog inputs have calibration adjustments. Onboard calibration DACs remove the offset and gain errors for each channel. For complete calibration instructions, refer to Chapter 5, [Calibration](#).

Antialias Filtering

A sampling system (such as an ADC) can represent signals of only limited bandwidth. Specifically, a sampling rate of f_s can only represent signals with a maximum frequency of $f_s/2$. This maximum frequency is known as the *Nyquist frequency*. If a signal is input to the sampling system with frequency components that exceed the Nyquist frequency, the sampler cannot distinguish these parts of the signal from some signals with frequency components less than the Nyquist frequency.

For example, suppose a sampler (such as an ADC) is sampling at 1,000 S/s. If a 400 Hz sine wave is input, then the resulting samples accurately represent a 400 Hz sine wave. However, if a 600 Hz sine wave is input, the resulting samples again appear to represent a 400 Hz sine wave because this signal exceeds the Nyquist frequency (500 Hz) by 100 Hz. In fact, any sine wave with a frequency greater than 500 Hz that is input is represented incorrectly as a signal between 0 and 500 Hz. The apparent frequency of this sine wave is the absolute value of the difference between the frequency

of the input signal and the closest integer multiple of 1,000 Hz (the sampling rate). Therefore, if a 2,325 Hz sine wave is input, its apparent frequency is:

$$2,325 - (2)(1,000) = 325 \text{ Hz.}$$

If a 3,975 Hz sine wave is input, its apparent frequency is:

$$(4)(1,000) - 3,975 = 25 \text{ Hz.}$$

The process by which the sampler modulates these higher frequency signals back into the 0 to 500 Hz baseband is called *aliasing*.

If the signal in the previous example is not a sine wave, the signal can have many components (harmonics) that lie above the Nyquist frequency. If present, these harmonics are erroneously aliased back into the baseband and added to the parts of the signal that are sampled accurately, producing a distorted sampled data set. To avoid this, it is important to input to the sampler only those signals that can be accurately represented—those whose frequency components all lie below the Nyquist frequency. To make sure that only those signals go into the sampler, a lowpass filter is applied to signals before they reach the sampler.

The PCI-445X includes two stages of anti-alias filtering in each input channel lowpass filter. This filter has a cutoff frequency of about 4 MHz and a rejection of greater than 40 dB at 20 MHz. Because its cutoff frequency is significantly higher than the data sample rate, the analog filter has an extremely flat frequency response in the bandwidth of interest, and it has very little phase error.

The analog filter precedes the analog sampler, which operates at 128 times the selected sample rate (26.2144 MS/s in the case of a 204.8 kS/s sample rate) and is actually a 1-bit ADC. The 1-bit, 128-times oversampled data that the analog sampler produces is passed on to a digital antialiasing filter that is built into the ADC chip. This filter also has extremely flat frequency response and no phase error, but its roll-off near the cutoff frequency (about 0.493 times the sample rate) is extremely sharp, and the rejection above 0.536 times the sample rate is greater than 85 dB. The output stage of the digital filter resamples the higher frequency data stream at the output data rate, producing 16-bit digital samples.

The digital filter in each channel passes only those signal components with frequencies that lie below the Nyquist frequency or within one Nyquist bandwidth of multiples of 128 times the sample rate. The analog filter in each channel rejects possible aliases (mostly noise) from signals that lie near these multiples. Figures 6-1 and 6-2 show the frequency response of the PCI-445X input circuitry.

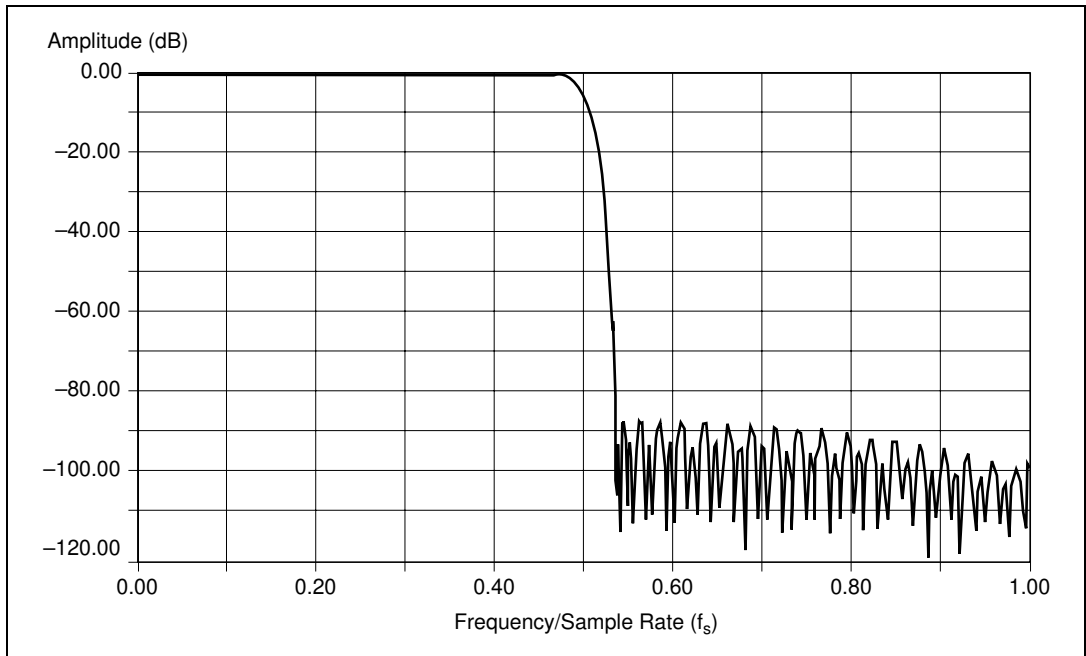

Figure 6-1. Input Frequency Response

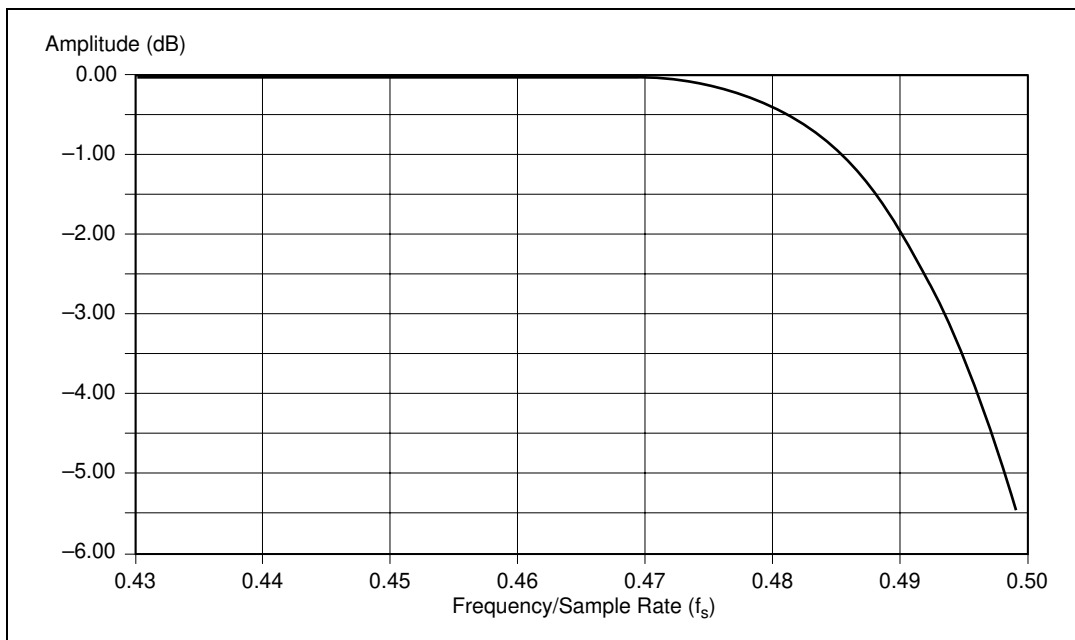

Figure 6-2. Input Frequency Response Near the Cutoff

Because the ADC samples at 128 times the data rate, frequency components above 64 times the data rate can alias. The digital filter rejects most of the frequency range over which aliasing can occur. However, the filter can do nothing about components that lie close to 128 times the data rate, 256 times the data rate, and so on, because it cannot distinguish these components from components in the baseband (0 Hz to the Nyquist frequency). If, for instance, the sample rate is 50 kS/s and a signal component lies within 25 kHz of 6.4 MHz (128×50 kHz), this signal is aliased into the passband region of the digital filter and is not attenuated. The purpose of the analog filter is to remove these higher frequency components near multiples of the oversampling rate before they get to the sampler and the digital filter.

While the frequency response of the digital filter scales in proportion to the sample rate, the frequency response of the analog filter remains fixed. The response of the filter is optimized to produce good high-frequency alias rejection while having a flat in-band frequency response. Because this filter is third order, its roll-off is rather slow. This means that, although the filter has good alias rejection for high sample rates, it does not reject as well at lower sample rates. The alias rejection near 128 times the sample rate

versus sample rate for the PCI-4451/4452 is illustrated in Figure 6-3, and for the PCI-4453/4454 in Figure 6-4. For frequencies not near multiples of the oversample rate, the rejection is better than 85 dB.

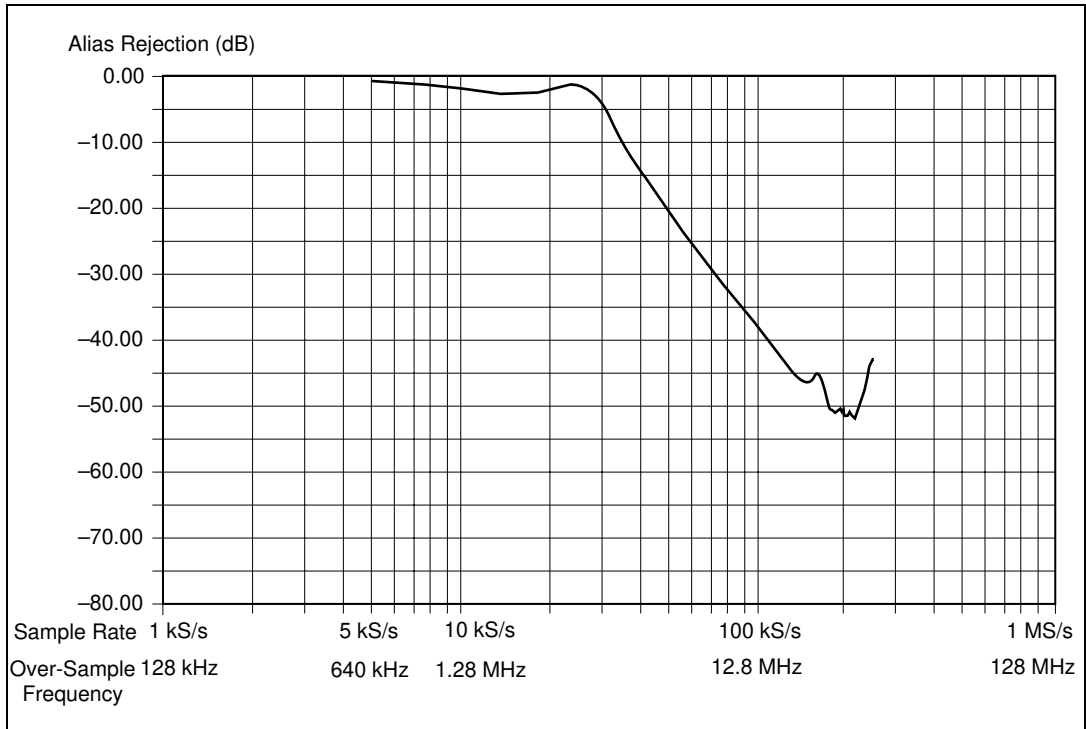

Figure 6-3. Alias Rejection at the Oversample Rate for the PCI-4451/4452

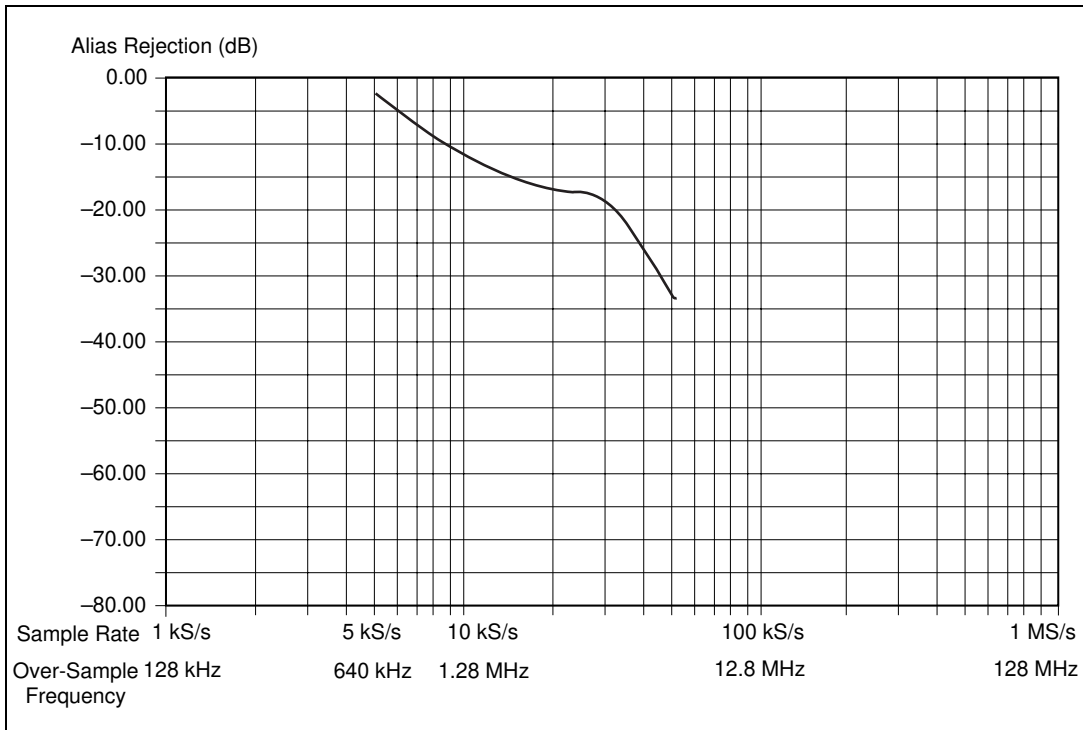

Figure 6-4. Alias Rejection at the Oversample Rate for the PCI-4453/4454

No filter can prevent a type of aliasing caused by a *clipped* or *overranged* waveform, that is, one that exceeds the voltage range of the ADC. When clipping occurs, the ADC assumes the closest value in its digital range to the actual value of the signal, which is always either $-32,768$ or $+32,767$. Clipping nearly always results in an abrupt change in the slope of the signal and causes the corrupted digital data to have high-frequency energy. This energy is spread throughout the frequency spectrum, and because the clipping happens *after* the antialiasing filters, the energy is aliased back into the baseband. The remedy for this problem is simple: do not allow the signal to exceed the nominal input range. Figure 6-5 shows the spectra of $10.5 V_{\text{rms}}$ and $10.0 V_{\text{rms}}$, 3.0 kHz sine waves digitized at 48 kS/s . The signal-to-THD-plus-noise (THD+N) ratio is 35 dB for the clipped waveform and 92 dB for the properly ranged waveform. Aliases of all the harmonics due to clipping appear in Figure 6-5a.

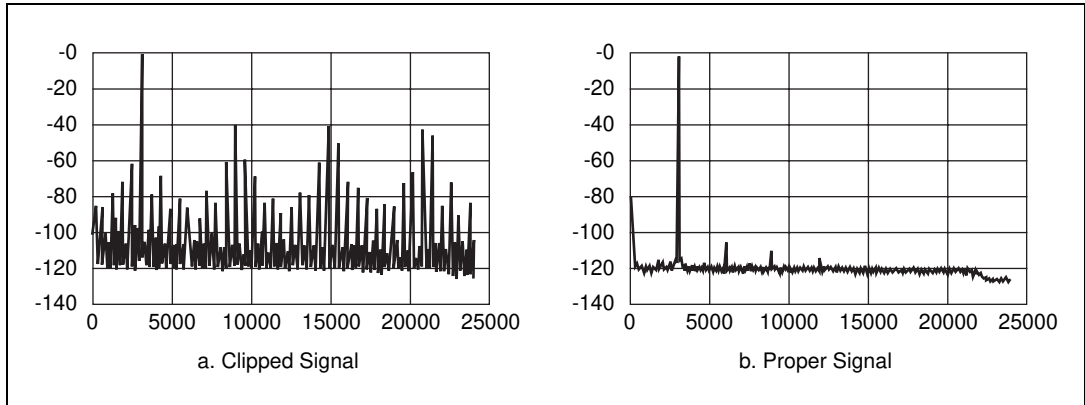

Figure 6-5. Comparison of a Clipped Signal to a Proper Signal

An overrange can occur on the analog signal as well as on the digitized signal. Furthermore, an analog overrange can occur independently from a digital overrange and vice-versa. For example, a piezoelectric accelerometer might have a resonant frequency that, when stimulated, can produce an overrange in the analog signal, but because the delta-sigma technology of the ADC uses very sharp antialiasing filters, the overrange is not passed into the digitized signal. Conversely, a sharp transient on the analog input might not overrange, but due to the step response of those same delta-sigma antialiasing filters, the digitized data might be clipped.

The ADC

The PCI-445X ADC uses a method of A/D conversion known as delta-sigma modulation. If the data rate is 51.2 kS/s, each ADC actually samples its input signal at 6.5536 MS/s (128 times the data rate) and produces 1-bit samples that are applied to the digital filter. This filter then expands the data to 16 bits, rejects signal components greater than 25.6 kHz (the Nyquist frequency), and resamples the data at the more conventional rate of 51.2 kS/s.

Although a 1-bit quantizer introduces a large amount of quantization error to the signal, the 1-bit, 6.5536 MS/s from the ADC carry all the information used to produce 16-bit samples at 51.2 kS/s. The delta-sigma ADC achieves this conversion from high speed to high resolution by adding a large amount of random noise to the signal so that the resulting quantization noise, although large, is restricted to frequencies above 25.6 kHz. This noise is not correlated with the input signal and is almost completely rejected by the digital filter.

The resulting output of the filter is a band-limited signal with a dynamic range of over 90 dB. One of the advantages of a delta-sigma ADC is that it uses a 1-bit DAC as an internal reference, whereas most 16-bit ADCs use 16-bit resistor-network DACs or capacitor-network DACs. As a result, the delta-sigma ADC is free from the kind of differential nonlinearity (DNL) that is inherent in most high-resolution ADCs. This lack of DNL is especially beneficial when the ADC is converting low-level signals, in which noise and distortion are directly affected by converter DNL.

Noise

The PCI-445X analog inputs typically have a dynamic range of more than 90 dB. The dynamic range of a circuit is the ratio of the magnitudes of the largest signal the circuit can carry to the residual noise in the absence of a signal. In a 16-bit system, the largest signal is taken to be a full-scale sine wave that peaks at the codes +32,767 and -32,768. Such a sine wave has an rms magnitude of $32,768 / 1.414 = 23,170.475$ least significant bits (LSBs).

A grounded channel of the PCI-445X has a noise level of about 0.65 LSB rms (this amount fluctuates). The ratio of $23,170.475 / 0.65$ is about 35647, or 91.0 dB—the dynamic range, but several factors can degrade the noise performance of the inputs.

One of these factors is noise picked up from nearby electronic devices. The PCI-445X works best when it is kept as far away as possible from other plug-in devices, power supplies, disk drives, and computer monitors. Cabling is also critical. Make sure to use well-shielded coaxial or balanced cables for all connections, and route the cables away from sources of interference such as computer monitors, switching power supplies, and fluorescent lights. Refer to the *Field Wiring Considerations* section of Chapter 4, *Signal Connections*, for more information.

One way to reduce the effects of noise on your measurements is to choose the sample rate carefully. Take advantage of the anti-alias filtering that removes signals beyond the band of interest. Computer monitor noise, for example, typically occurs at frequencies between 15 and 50 kHz. If the signal of interest is restricted to below 10 kHz, for example, the anti-alias filters reject the monitor noise outside the frequency band of interest. The frequency response inside the band of interest is not influenced if the sample rate is between roughly 21.6 and 28 kS/s.

Analog Output Circuitry (PCI-4451/4453 Only)

- ◆ PCI-4451

The PCI-4451 has two identical analog output channels. A block diagram of one channel is shown in Figure 4-6, *Analog Output Channel Block Diagram for the PCI-4451*. The PCI-4451 can drive the output signal as SE or DIFF and allows for attenuation of the signal by 0, -20, -40 dB.

- ◆ PCI-4453

The PCI-4453 has two identical analog output channels. A block diagram of one channel is shown in Figure 4-7, *Analog Output Channel Block Diagram for the PCI-4453*. The PCI-4453 drives the output signal as SE only and does not allow for attenuation.

- ◆ PCI-4451/4453

A common application for the analog output is to stimulate a system under test while measuring the response with the analog inputs. The input and output sample clocks are synchronized and derived from the same DDS clock. The input and output clocks can differ from each other by a factor of 2 (1, 2, 4, 8, ... 128) while still maintaining their synchronization. Output conversions occur simultaneously at software-programmable rates from 1.25 to 51.2 kS/s in increments of 47.684 μ S/s.

The analog output circuitry uses eight-times oversampling interpolators with 64-times oversampling delta-sigma modulators to generate high-quality signals. The output channel has a range up to ± 10 V ($7.07 V_{\text{rms}}$).

Because of the delta-sigma modulating DAC, the device is immune to DNL distortion. The analog output stage generates signals with extremely low noise and low distortion. Because the device has a 90 dB dynamic range, it is possible to generate low-noise waveforms. The device also has excellent amplitude flatness of ± 0.2 dB within the frequency range of DC to 23 kHz and has a THD of -90 dB at 1 kHz. With these specifications, you are assured of the quality and integrity of the output signals generated.

Anti-Image Filtering

A sampled signal repeats itself throughout the frequency spectrum. These repetitions begin above one-half the sample rate (F_s) and, theoretically, continue up through the spectrum to infinity, as shown in Figure 6-6a. Because the sample data actually represents only the frequency components below one-half the sample rate (the baseband), it is desirable to filter out all these extra images of the signal. The PCI-4451/4453 accomplishes this filtering in two stages.

First, the data is digitally resampled at eight times the original sample rate, then a linear-phase digital filter removes almost all energy above one-half the original sample rate and sends the data at the eight-times rate to the DAC, as shown in Figure 6-6b. Some further (inherent) filtering occurs at the DAC because the data is digitally sampled and held at eight times the sample rate. This filtering has a $\sin x/x$ response, yielding nulls at multiples of eight times the sample rate, as shown in Figure 6-6c. Still, images remain, and they must be filtered out. Each output channel of the PCI-4451/4453 has discrete-time (switched-capacitor) and continuous-time analog filters that remove the high-frequency images, as shown in Figure 6-6d.

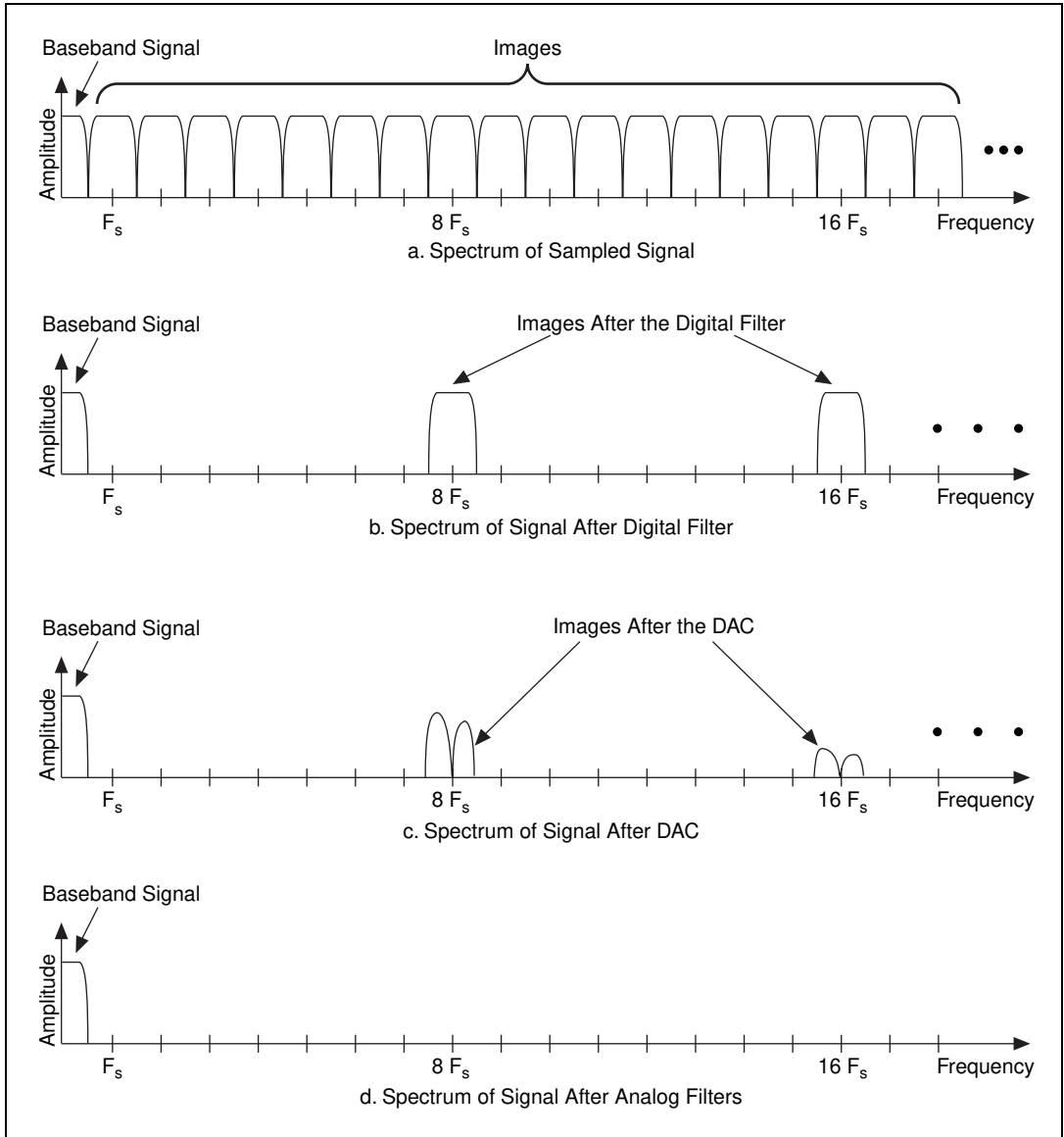

Figure 6-6. Signal Spectra in the DAC

The DAC

The 64-times oversampling delta-sigma DACs on the PCI-4451/4453 work in the same way as delta-sigma ADCs, only in reverse. The digital data first passes through a digital lowpass filter and then goes to the delta-sigma modulator.

In the ADC the delta-sigma modulator is analog circuitry that converts high-resolution *analog* signals to high-rate, 1-bit digital data, whereas in the DAC the delta-sigma modulator is digital circuitry that converts high-resolution *digital* data to high-rate, 1-bit digital data. As in the ADC, the modulator frequency-shapes the quantization noise so that almost all of its energy is above the signal frequency. Refer to [The ADC](#) for more information.

The digital 1-bit data is then sent directly to a simple 1-bit DAC. This DAC can have only one of two analog values, and therefore is inherently perfectly linear. The output of the DAC, however, has a large amount of quantization noise at higher frequencies, and, as described in the [Anti-Image Filtering](#) section, some images still remain near multiples of eight times the sample rate.

Two analog filters eliminate the quantization noise and the images. The first is a fifth-order, switched-capacitor filter in which the cutoff frequency scales with the sample frequency and is approximately 0.52 times the sample frequency. This filter has a four-pole Butterworth response and an extra pole at about 1.04 times the sample frequency.

The second filter is a continuous-time, second-order Butterworth filter in which the cutoff frequency (at 80 kHz) does not scale with the sample frequency. This filter mainly removes high-frequency images from the 64-times oversampled switched-capacitor filter. These filters cause a delay between the input digital data and the output analog data of 34.6 ± 0.5 sample periods.

Calibration

The PCI-4451/4453 analog outputs have calibration adjustments. Onboard calibration DACs remove the offset and gain errors for each channel. For complete calibration instructions, refer to Chapter 5, [Calibration](#).

Mute Feature

The two-channel DAC chip on the PCI-4451/4453 goes into *mute* mode if the chip receives at least 4,096 consecutive zero values on both channels at once. In mute mode, the outputs clamp to ground and the noise floor drops from about 92 dB below full-scale to about 120 dB below full-scale. Upon receiving any nonzero data, the DAC instantly reverts to normal mode. Mute mode is designed to quiet the background noise to extremely low levels when no waveforms are being generated. Mute mode has a slightly different offset from the normal offset when zeros are being sent. As a result, the DAC has one offset for the first 4,096 zero samples and another offset in mute mode for as long as zeros are sent. This difference is usually less than 1 mV.

Specifications

This appendix lists the specifications of the PCI-445X. These specifications are typical at 25 °C unless otherwise noted. The system must be allowed to warm-up for 15 minutes to achieve the rated accuracy.



Note Be sure to keep the cover on your computer to maintain forced air cooling.

Analog Input

Channel Characteristics

Number of channels

Device	Number of Channels	Input Configuration
4451	2	Simultaneously sampled true differential
4452	4	
4453	2	Single-ended
4454	4	

Resolution 16 bits

Type of ADC..... Delta-sigma, 128-times oversampling

Sample rates

Device	Sample Rates
4451	5 kS/s to 204.8 kS/s in increments of 190.735 μ S/s
4452	
4453	5 kS/s to 51.2 kS/s in increments of 47.684 μ S/s
4454	

Frequency accuracy±25 ppm

Input signal ranges (software selectable for PCI-4451/4452)

Device	Gain		Full-scale Range (Peak)
	Linear	Log	
4451/4452	0.1	-20 dB	±42.4 V
	0.316	-10 dB	±31.6 V
	1	0 dB	±10.0
	3.16	+10 dB	±3.16 V
	10	+20 dB	±1.00 V
	31.6	+30 dB	±0.316 V
	100	+40 dB	±0.100 V
	316	+50 dB	±0.0316 V
	1000	+60 dB	±0.0100 V
4453/4454	1	0 dB	±10 V

FIFO buffer size.....512 samples

Data transfersDMA, programmed I/O, interrupt

Transfer Characteristics

INL (relative accuracy).....±2 LSB

DNL±0.5 LSB typ, ±1 LSB max,
no missing codes

Offset (residual DC)

Device	Gain	Max Offset
4451/4452	-20 dB	±30 mV
	-10 dB	±10 mV
	0 dB	±3 mV
	+10 dB	±1 mV
	+20 dB	±300 µV
	+30, +40, +50, +60 dB	±100 µV
4453/4454	0 dB	±3 mV

Gain (amplitude accuracy) ±0.1 dB, $f_{in} = 1$ kHz

Amplifier Characteristics

Input impedance

PCI-4451/4452 1 M Ω in parallel with 50 pF
(+ and - each to AIGND)PCI-4453/4454 1 M Ω in parallel with 50 pF
(+ to AIGND)

Flatness (relative to 1 kHz)

Device	Gain	Flatness
4451/4452	0, +10, +20, +30, +40 dB	±0.1 dB, 0 to 95 kHz, 204.8 kS/s, DC coupling
	-20, -10, +50, +60 dB	±1 dB, 0 to 95 kHz, ±0.1 dB, 0 to 20 kHz, 204.8 kS/s, DC coupling
4453/4454	0 dB	±0.1 dB, 0 to 23 kHz, 51.2 kS/s, DC coupling

-3 dB bandwidth 0.493 f_s

Input coupling AC or DC, software-selectable

AC -3 dB cutoff frequency 3.4 Hz

Common-mode range

Device	Gain	Common Mode Range
4451/4452	Gain ≥ 0 dB	both + and – should remain within ± 12 V of AIGND
	Gain < 0 dB	both + and – should remain within ± 42.4 V of AIGND
4453/4454	Gain = 0 dB	+ should remain within ± 12 V of AIGND

Overvoltage protection ± 42.4 V, powered on or off
 (± 400 V guaranteed by design,
 but not tested or certified to
 operate beyond ± 42.4 V)

Inputs protected ACH0, ACH1, ACH2, ACH3

Common mode rejection ratio (CMRR)

Device	Gain	CMRR
4451/4452	≥ 0 dB	90 dB
	< 0 dB	60 dB
4453/4454	0 dB	90 dB

◆ PCI-4451/4452

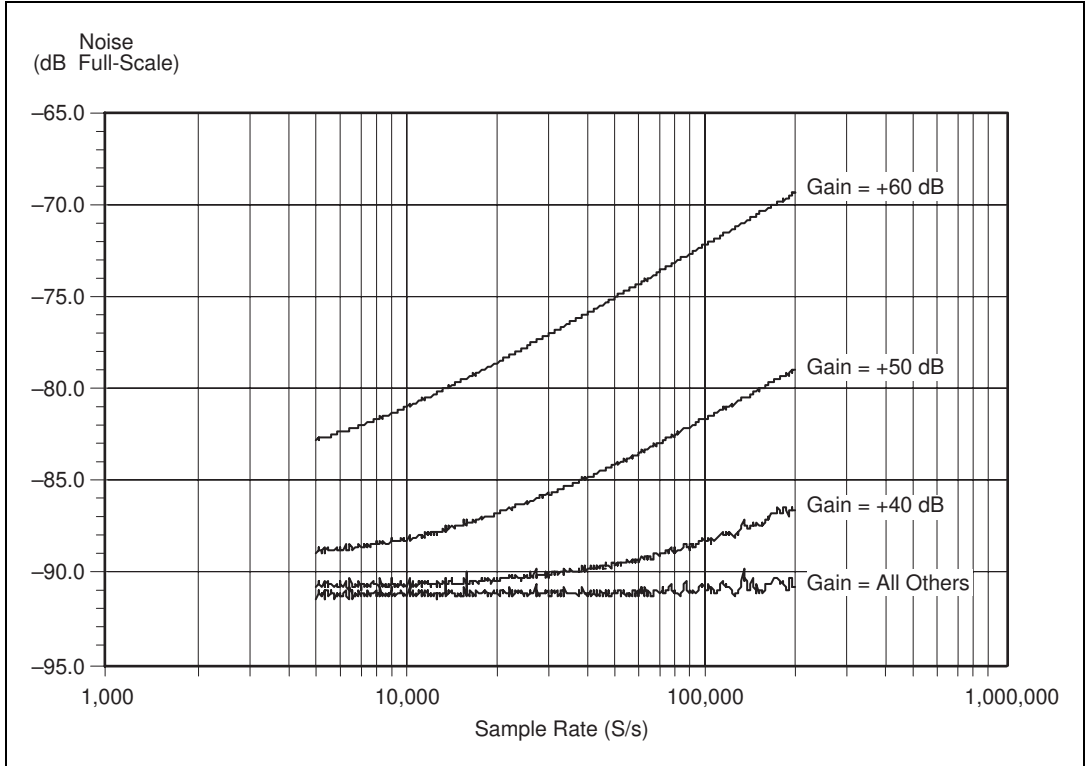

Figure A-1. PCI-4451/4452 Idle Channel Noise (Typical)

Input noise spectral density $8 \text{ nV}/\sqrt{\text{Hz}}$ (achievable only at Gain = +50 dB or +60 dB)

◆ PCI-4453/4454

Idle channel noise..... -90 dBFS

Dynamic Characteristics

Alias-free bandwidth..... DC to $0.464 f_s$

Alias rejection 80 dB, $0.536 f_s < f_{in} < 63.464 f_s$

Spurious-free dynamic range 95 dB

THD -80 dB; -90 dB for $f_{in} < 20 \text{ kHz}$ or signal $< 1 \text{ V}_{\text{rms}}$

IMD-100 dB (CCIF 14 kHz + 15 kHz)

Crosstalk (channel separation).....-100 dB, DC to 100 kHz

Phase linearity

Device	Gain	Phase Linearity
4451/4452	≥ 0 dB	±1°
	< 0 dB	±2°
4453/4454	0 dB	±1°

Interchannel phase

Device	Gain	Interchannel Phase
4451/4452	≥ 0 dB	±1°
	< 0 dB	±2°
4453/4454	0 dB	±1°

Interchannel gain mismatch.....±0.1dB, for all gains
(same configuration for all input channels)

Signal delay42 sample periods, any sample rate (time from when signal enters analog input to when digital data is available)

Onboard Calibration Reference

DC level.....5.000 V ±2.5 mV

Temperature coefficient.....±5 ppm/°C max

Long-term stability±15 ppm/ $\sqrt{1,000}$ h

Analog Output (PCI-4451/4453 Only)

Channel Characteristics

Number of channels	2 simultaneously updated
Output configuration	
PCI-4451	Balanced differential
PCI-4453	Single-ended
Resolution	16 bits
Type of DAC	Delta-sigma, 64-times oversampling
Sample rates	1.25 to 51.2 kS/s in increments of 47.684 μ S/s
Frequency accuracy	± 25 ppm
Output signal range (software-selectable for PCI-4451)	

Device	Attenuation		Full-scale Range
	Linear	Log	
4451	1	0 dB	± 10.0 V
	10	20 dB	± 1.00 V
	100	40 dB	± 0.100 V
4453	1	0 dB	± 10 V

FIFO buffer size	512 samples
Data transfers	DMA, programmed I/O, Interrupt

Transfer Characteristics

Offset (residual DC)	± 5 mV max, any gain
Gain (amplitude accuracy)	± 0.1 dB, $f_{out} = 1$ kHz

Voltage Output Characteristics

Output impedance

PCI-4451.....	22 Ω between +DACxOUT and –DACxOUT, 4.55 k Ω to AOGND
PCI-4453.....	22 Ω between +DACxOUT and AO_SHLD

Flatness (relative to 1 kHz)..... ± 0.2 dB, 0 to 23 kHz, 51.2 kS/s

–3 dB bandwidth..... $0.492 f_s$

Output couplingDC

Short-circuit protection

PCI-4451.....	yes (+ and – may be shorted together indefinitely)
PCI-4453.....	yes (output may be shorted to AO_SHLD or ground indefinitely)

Outputs protected

PCI-4451.....	\pm DAC0OUT, \pm DAC1OUT
PCI-4453.....	+DAC0OUT, +DAC1OUT

Idle channel noise–91 dBFS, DC to 23 kHz
measurement bandwidth

Dynamic Characteristics

Image-free bandwidth.....DC to $0.450 f_s$

Image rejection90 dB, $0.550 f_s < f_{out} < 63.450 f_s$

Spurious-free dynamic range.....90 dB, DC to 100 kHz
measurement bandwidth

THD–80 dB; –90 dB for $f_{out} < 5$ kHz
or signal $< 1 V_{rms}$

IMD–90 dB (CCIF 14 kHz + 15 kHz)

Crosstalk (channel separation).....–80 dB, DC to 23 kHz
measurement bandwidth

Phase linearity	$\pm 1^\circ$
Interchannel phase (same configuration both output channels)	$\pm 1^\circ$
Interchannel gain mismatch (same configuration both output channels)	± 0.1 dB, for all attenuations
Signal delay	34.6 \pm 0.5 sample periods, any sample rate (time from when digital data is expressed to when analog signal appears at output terminals)

Digital I/O (PCI-4451/4452 Only)

Number of channels	8 input/output
Compatibility	TTL/CMOS

Digital logic levels

Level	Min	Max
Input low voltage	0.0 V	0.8 V
Input high voltage	2.0 V	5.0 V
Input low current ($V_{in} = 0$ V)	—	-320 μ A
Input high current ($V_{in} = 5$ V)	—	10 μ A
Output low voltage ($I_{OL} = 24$ mA)	—	0.4 V
Output high voltage ($I_{OH} = 13$ mA)	4.35 V	—

Power-on state..... Input (high-impedance)

Data transfers

Programmed I/O

Timing I/O

Number of channels

2 up/down counter/timers,
1 frequency scaler

Resolution

Counter/timers

24 bits

Frequency scaler

4 bits

Compatibility	TTL/CMOS
Base clocks available	
Counter/timers	20 MHz, 100 kHz
Frequency scaler	10 MHz, 100 kHz
Base clock accuracy	±0.01%
Max source frequency	20 MHz
Min source pulse duration	10 ns, edge-detect mode
Min gate pulse duration	10 ns, edge-detect mode
Data transfers	DMA, interrupts, programmed I/O
DMA modes	Scatter gather

Triggers

Analog Trigger

Source	
PCI-4451/4453	ACH<0..1>
PCI-4452/4454	ACH<0..3>
Level	± full-scale
Slope	Positive or negative (software selectable)
Resolution	16 bits
Hysteresis	Programmable

Digital Trigger

Compatibility	TTL
Response	Rising or falling edge
Pulse width	10 ns min

Bus Interface

Type PCI Master/Slave

Power Specifications

PCI-4451

Requirements +5 V, 1.7 A idle, 2.0 A active
 +12 V, 100 mA typical
 (not including momentary relay
 switching)
 -12 V, 40 mA typical
 +3.3 V, unused

Available power

Analog I/O connector +4.65 to +5.25 VDC at 1.0 A
 Digital I/O connector +4.65 to +5.25 VDC at 1.0 A

PCI-4452

Requirements +5 V, 2.2 A idle, 2.5 A active
 +12 V, 150 mA typical
 (not including momentary relay
 switching)
 -12 V, unused
 +3.3 V, unused

Available power

Analog I/O connector) +4.65 to +5.25 VDC at 1.0 A
 Digital I/O connector) +4.65 to +5.25 VDC at 1.0 A

PCI-4453

Requirements +5 V, 850 mA idle, 1.0 A active
 +12 V, 100 mA typical
 (not including momentary relay
 switching)
 -12 V, 40 mA typical
 +3.3 V, unused

Available power

Analog I/O connector) +4.65 to +5.25 VDC at 1.0 A

PCI-4454

Requirements+5 V, 1.35 A idle, 1.5 A active
+12 V, 150 mA typical
(not including momentary relay
switching)
-12 V, unused
+3.3 V, unused

Available power

Analog I/O connector).....+4.65 to +5.25 VDC at 1.0 A

Physical

Dimensions

(not including connectors)10.65 by 31.19 by 1.84 cm
(4.19 by 12.28 by 0.73 in.)

Analog I/O connector68-pin VHDCI female type

◆ PCI-4451/4452

Digital I/O connector50-pin VHDCI female type

◆ PCI-4453/4454

Digital trigger connector.....SMB female type

Environment

Operating temperature0 °C to +40 °C

Storage temperature range-25 °C to +85 °C

Relative humidity10% to 95%, no condensation

Calibration

Calibration interval1 year

Pin Connections

This appendix illustrates the pin connections for the DB-25 connector on the optional SHC68-DB25 cable. It also illustrates the pin connections for the optional 68-pin digital accessories for the PCI-4451 and PCI-4452 devices.

+ACH0	1	14	-ACH0
GND	2	15	GND
+ACH1	3	16	-ACH1
NC	4	17	NC
+ACH2	5	18	-ACH2
GND	6	19	GND
+ACH3	7	20	-ACH3
NC	8	21	NC
+DAC0OUT	9	22	-DAC0OUT
GND	10	23	GND
+DAC1OUT	11	24	-DAC1OUT
GND	12	25	GND
+5 V	13		

Figure B-1. DB-25 Pinout for the SHC68-DB25 Cable

FREQ_OUT	1	35	DGND
PFI9/GPCTR0_GATE	2	36	DGND
GPCTR0_OUT	3	37	DGND
PFI8/GPCTR0_SOURCE	4	38	DGND
UPDATE*	5	39	DGND
PFI6/WFTRIG	6	40	DGND
PFI7	7	41	DGND
PFI4/GPCTR1_GATE	8	42	DGND
GPCTR1_OUT	9	43	DGND
PFI3/GPCTR1_SOURCE	10	44	DGND
PFI0/TRIG1 (EXT_TRIG)	11	45	DGND
PFI1/TRIG2 (PRETRIG)	12	46	DGND
CONVERT*	13	47	DGND
RESERVED1	14	48	DGND
DIO7	15	49	DGND
DIO6	16	50	DGND
DIO5	17	51	DGND
DIO4	18	52	DGND
DIO3	19	53	DGND
EXTSTROBE*	20	54	DGND
DIO2	21	55	DGND
DIO1	22	56	DGND
DIO0	23	57	DGND
+5 V	24	58	+5 V
NC	25	59	DGND
NC	26	60	DGND
NC	27	61	DGND
NC	28	62	DGND
NC	29	63	DGND
NC	30	64	DGND
NC	31	65	DGND
NC	32	66	DGND
NC	33	67	DGND
NC	34	68	DGND

Figure B-2. 68-Pin Digital Connector for Any Digital Accessory



Technical Support Resources

This appendix describes the comprehensive resources available to you in the Technical Support section of the National Instruments Web site and provides technical support telephone numbers for you to use if you have trouble connecting to our Web site or if you do not have internet access.

NI Web Support

To provide you with immediate answers and solutions 24 hours a day, 365 days a year, National Instruments maintains extensive online technical support resources. They are available to you at no cost, are updated daily, and can be found in the Technical Support section of our Web site at www.ni.com/support

Online Problem-Solving and Diagnostic Resources

- **KnowledgeBase**—A searchable database containing thousands of frequently asked questions (FAQs) and their corresponding answers or solutions, including special sections devoted to our newest products. The database is updated daily in response to new customer experiences and feedback.
- **Troubleshooting Wizards**—Step-by-step guides lead you through common problems and answer questions about our entire product line. Wizards include screen shots that illustrate the steps being described and provide detailed information ranging from simple getting started instructions to advanced topics.
- **Product Manuals**—A comprehensive, searchable library of the latest editions of National Instruments hardware and software product manuals.
- **Hardware Reference Database**—A searchable database containing brief hardware descriptions, mechanical drawings, and helpful images of jumper settings and connector pinouts.
- **Application Notes**—A library with more than 100 short papers addressing specific topics such as creating and calling DLLs, developing your own instrument driver software, and porting applications between platforms and operating systems.

Software-Related Resources

- **Instrument Driver Network**—A library with hundreds of instrument drivers for control of standalone instruments via GPIB, VXI, or serial interfaces. You also can submit a request for a particular instrument driver if it does not already appear in the library.
- **Example Programs Database**—A database with numerous, non-shipping example programs for National Instruments programming environments. You can use them to complement the example programs that are already included with National Instruments products.
- **Software Library**—A library with updates and patches to application software, links to the latest versions of driver software for National Instruments hardware products, and utility routines.

Worldwide Support

National Instruments has offices located around the globe. Many branch offices maintain a Web site to provide information on local services. You can access these Web sites from www.ni.com/worldwide

If you have trouble connecting to our Web site, please contact your local National Instruments office or the source from which you purchased your National Instruments product(s) to obtain support.

For telephone support in the United States, dial 512 795 8248. For telephone support outside the United States, contact your local branch office:

Australia 03 9879 5166, Austria 0662 45 79 90 0, Belgium 02 757 00 20,
Brazil 011 284 5011, Canada (Calgary) 403 274 9391,
Canada (Ontario) 905 785 0085, Canada (Québec) 514 694 8521,
China 0755 3904939, Denmark 45 76 26 00, Finland 09 725 725 11,
France 01 48 14 24 24, Germany 089 741 31 30, Greece 30 1 42 96 427,
Hong Kong 2645 3186, India 91805275406, Israel 03 6120092,
Italy 02 413091, Japan 03 5472 2970, Korea 02 596 7456,
Mexico (D.F.) 5 280 7625, Mexico (Monterrey) 8 357 7695,
Netherlands 0348 433466, New Zealand 09 914 0488,
Norway 32 27 73 00, Poland 0 22 528 94 06, Portugal 351 1 726 9011,
Singapore 2265886, Spain 91 640 0085, Sweden 08 587 895 00,
Switzerland 056 200 51 51, Taiwan 02 2528 7227,
United Kingdom 01635 523545

Glossary

Prefix	Meanings	Value
p-	pico-	10^{-12}
n-	nano-	10^{-9}
μ -	micro-	10^{-6}
m-	milli-	10^{-3}
k-	kilo-	10^3
M-	mega-	10^6
G-	giga-	10^9

Numbers/Symbols

°	degree
Ω	ohm
%	percent
+	positive of, or plus
-	negative of, or minus
/	per

A

A	amperes
AC	alternating current
AC coupled	allowing the transmission of AC signals while blocking DC signals
A/D	analog-to-digital

ADC	analog-to-digital converter—an electronic device, often an integrated circuit, that converts an analog voltage to a digital number
ADC resolution	the size of the discrete steps in the ADCs input-to-output transfer function; therefore, the smallest voltage difference an ADC can discriminate with a single measurement
AI Convert	LabVIEW name for CONVERT*. <i>See</i> CONVERT*.
AI Start Trigger	LabVIEW name for TRIG1. <i>See</i> TRIG1.
AI Stop Trigger	LabVIEW name for TRIG2. <i>See</i> TRIG2.
alias	a false lower frequency component that appears in sampled data acquired at too low a sampling rate
amplification	a type of signal conditioning that improves accuracy in the resulting digitized signal and reduces noise
amplitude flatness	a measure of how close to constant the gain of a circuit remains over a range of frequencies
AO Start Trigger	LabVIEW name for WFTRIG. <i>See</i> WFTRIG.
AO Update	LabVIEW name for UPDATE*. <i>See</i> UPDATE*.
asynchronous	(1) hardware—a property of an event that occurs at an arbitrary time, without synchronization to a reference clock; (2) software—a property of a function that begins an operation and returns prior to the completion or termination of the operation
attenuate	to decrease the amplitude of a signal
B	
bandwidth	the range of frequencies present in a signal, or the range of frequencies to which a measuring device can respond
bipolar	a signal range that includes both positive and negative values (for example, -5 V to +5 V)
BNC	a type of coaxial signal connector
buffer	temporary storage for acquired or generated data (software)

bus the group of conductors that interconnect individual circuitry in a computer. Typically, a bus is the expansion vehicle to which I/O or other devices are connected. Examples of PC buses are the ISA and PCI bus.

C

C Celsius

CalDAC calibration DAC

CCIF *See* IMD.

channel pin or wire lead to which you apply or from which you read the analog or digital signal. Analog signals can be single-ended or differential. For digital signals, you group channels to form ports. Ports usually consist of either four or eight digital channels.

circuit trigger a condition for starting or stopping clocks

clip clipping occurs when an input signal exceeds the input range of the amplifier

clock hardware component that controls timing for reading from or writing to groups

CMOS complementary metal-oxide semiconductor

CMRR common-mode rejection ratio—a measure of an instrument’s ability to reject interference from a common-mode signal, usually expressed in decibels (dB)

code width the smallest detectable change in an input voltage of a DAQ device

common-mode range the input range over which a circuit can handle a common-mode signal

common-mode signal the mathematical average voltage, relative to the computer’s ground, of the signals from a differential input

common-mode voltage any voltage present at both instrumentation amplifier inputs with respect to amplifier ground

conditional retrieval a method of triggering in which you simulate an analog trigger using software. Also called software triggering.

conversion device	device that transforms a signal from one form to another. For example, analog-to-digital converters (ADCs) for analog input, digital-to-analog converters (DACs) for analog output, digital input or output ports, and counter/timers are conversion devices.
conversion time	the time required, in an analog input or output system, from the moment a channel is interrogated (such as with a read instruction) to the moment that accurate data is available
CONVERT*	convert signal
counter/timer	a circuit that counts external pulses or clock pulses (timing)
coupling	the manner in which a signal is connected from one location to another
crosstalk	an unwanted signal on one channel due to an input on a different channel
current drive capability	the amount of current a digital or analog output channel is capable of sourcing or sinking while still operating within voltage range specifications
current sinking	the ability of a DAQ device to dissipate current for analog or digital output signals
current sourcing	the ability of a DAQ device to supply current for analog or digital output signals

D

D/A	digital-to-analog
DAC	digital-to-analog converter—an electronic device, often an integrated circuit, that converts a digital number into a corresponding analog voltage or current
DAQ	data acquisition—(1) collecting and measuring electrical signals from sensors, transducers, and test probes or fixtures and inputting them to a computer for processing; (2) collecting and measuring the same kinds of electrical signals with A/D and/or DIO devices plugged into a computer, and possibly generating control signals with D/A and/or DIO devices in the same computer
dB	decibel—the unit for expressing a logarithmic measure of the ratio of two signal levels: $\text{dB} = 20\log_{10} (V_1/V_2)$, for signals in volts

dBFS	absolute signal level compared to full scale
DC	direct current
DC coupled	allowing the transmission of both AC and DC signals
DDS clock	Direct Digital Synthesis clock—a type of clock source with an output frequency controlled by a digital input word
default setting	a default parameter value recorded in the driver. In many cases, the default input of a control is a certain value (often 0) that means <i>use the current default setting</i> . For example, the default input for a parameter may be <i>do not change current setting</i> , and the default setting may be <i>no AMUX-64T devices</i> . If you do change the value of such a parameter, the new value becomes the new setting. You can set default settings for some parameters in the configuration utility or manually using switches located on the device.
delta-sigma modulating ADC	a high-accuracy circuit that samples at a higher rate and lower resolution than is needed and (by means of feedback loops) pushes the quantization noise above the frequency range of interest. This out-of-band noise is typically removed by digital filters.
device	a plug-in data acquisition device, card, or pad that can contain multiple channels and devices. Plug-in boards, PCMCIA cards, and devices such as the DAQPad-1200, which connects to your computer parallel port, are all examples of DAQ devices. SCXI modules are distinct from devices, with the exception of the SCXI-1200, which is a hybrid.
DIFF	differential mode
differential input	an analog input consisting of two terminals, both of which are isolated from computer ground, whose difference is measured
differential measurement system	a way you can configure your device to read signals, in which you do not need to connect either input to a fixed reference, such as the earth or a building ground
digital port	<i>See</i> port.
digital trigger	a TTL level signal having two discrete levels—a high and a low level

DIO	digital input/output
DMA	direct memory access—a method by which data can be transferred to/from computer memory from/to a device or memory on the bus while the processor does something else. DMA is the fastest method of transferring data to/from computer memory.
DNL	differential nonlinearity—a measure in LSBs of the worst-case deviation of code widths from their ideal value of 1 LSB
down counter	performing frequency division on an internal signal
drivers	software that controls a specific hardware device such as a DAQ device or a GPIB interface device
DSA	dynamic signal acquisition
dynamic range	the ratio of the largest signal level a circuit can handle to the smallest signal level it can handle (usually taken to be the noise level), normally expressed in decibels

E

EEPROM	electrically erasable programmable read-only memory—ROM that can be erased with an electrical signal and reprogrammed
event	the condition or state of an analog or digital signal
external trigger	a voltage pulse from an external source that triggers an event such as A/D conversion
EXTSTROBE*	external strobe signal

F

false triggering	triggering that occurs at an unintended time
------------------	--

FIFO	first-in first-out memory buffer—the first data stored is the first data sent to the acceptor. FIFOs are often used on DAQ devices to temporarily store incoming or outgoing data until that data can be retrieved or output. For example, an analog input FIFO stores the results of A/D conversions until the data can be retrieved into system memory, a process that requires the servicing of interrupts and often the programming of the DMA controller. This process can take several milliseconds in some cases. During this time, data accumulates in the FIFO for future retrieval. With a larger FIFO, longer latencies can be tolerated. In the case of analog output, a FIFO permits faster update rates, because the waveform data can be stored on the FIFO ahead of time. This again reduces the effect of latencies associated with getting the data from system memory to the DAQ device.
filtering	a type of signal conditioning that allows you to attenuate unwanted portions of the signal you are trying to measure
f_{in}	input signal frequency
FIR	finite impulse response—a non recursive digital filter with linear phase
flash ADC	an ADC whose output code is determined in a single step by a bank of comparators and encoding logic
floating signal sources	signal sources with voltage signals that are not connected to an absolute reference or system ground. Also called nonreferenced signal sources. Some common example of floating signal sources are batteries, transformers, or thermocouples.
f_{out}	output signal frequency
FREQ_OUT	frequency signal
f_s	sampling frequency or rate
G	
gain	the factor by which a signal is amplified, sometimes expressed in decibels
gain accuracy	a measure of deviation of the gain of an amplifier from the ideal gain
GPCTR0_GATE	general-purpose counter timer 0 gate signal
GPCTR0_OUT	general-purpose counter timer 0 output signal

GPCTR0_SOURCE	general-purpose counter timer 0 clock source signal
GPCTR1_GATE	general-purpose counter timer 1 gate signal
GPCTR1_OUT	general-purpose counter timer 1 output signal
GPCTR1_SOURCE	general-purpose counter timer 1 clock source signal
grounded measurement system	See SE.

H

h	hour
hardware	the physical components of a computer system, such as the circuit boards, plug-in boards, chassis, enclosures, peripherals, and cables
hardware triggering	a form of triggering where you set the start time of an acquisition and gather data at a known position in time relative to a trigger signal
high-impedance	in logic circuits designed to have three possible states—0, 1, and hi-Z—the hi-Z (high impedance) state effectively removes the output from its circuit, and can be used to simplify bus communication by wire-ANDing tri-state inputs
Hz	hertz—cycles per second. Specifically refers to the repetition frequency of a waveform.

I

IC	integrated circuit
IMD	intermodulation distortion—the ratio, in dB, of the total rms signal level of harmonic sum and difference distortion products, to the overall rms signal level. The test signal is two sine waves added together according to the following standards: CCIF—A 14 kHz sine wave and a 15 kHz sine wave added in a 1:1 amplitude ratio.
in.	inches

INL	integral nonlinearity—a measure in LSB of the worst-case deviation from the ideal A/D or D/A transfer characteristic of the analog I/O circuitry
input impedance	the measured resistance and capacitance between the input terminals of a circuit
instrument driver	a set of high-level software functions that controls a specific GPIB, VXI, or RS-232 programmable instrument or a specific plug-in DAQ device. Instrument drivers are available in several forms, ranging from a function callable language to a virtual instrument (VI) in LabVIEW.
instrumentation amplifier	a circuit whose output voltage with respect to ground is proportional to the difference between the voltages at its two inputs
interrupt	a computer signal indicating that the CPU should suspend its current task to service a designated activity
I/O	input/output—the transfer of data to/from a computer system involving communications channels, operator interface devices, and/or data acquisition and control interfaces
I_{OH}	current, output high
I_{OL}	current, output low
IRQ	interrupt request
isolation	a type of signal conditioning in which you isolate the transducer signals from the computer for safety purposes. This protects you and your computer from large voltage spikes and makes sure the measurements from the DAQ device are not affected by differences in ground potentials.
K	
k	kilo—the standard metric prefix for 1,000, or 10^3 , used with units of measure such as volts, hertz, and meters
kS	1,000 samples

L

LabVIEW	laboratory virtual instrument engineering workbench
library	a file containing compiled object modules, each comprised of one or more functions, that can be linked to other object modules that make use of these functions. <code>nidaqmsc.lib</code> is a library that contains NI-DAQ functions. The NI-DAQ function set is broken down into object modules so that only the object modules that are relevant to your application are linked in, while those object modules that are not relevant are not linked.
linearity	the adherence of device response to the equation $R = KS$, where R = response, S = stimulus, and K = a constant
linearization	a type of signal conditioning in which software linearizes the voltage levels from transducers, so the voltages can be scaled to measure physical phenomena
LSB	least significant bit

M

memory buffer	<i>See</i> buffer.
MS	million samples
MSB	most significant bit

N

NC	normally closed, or not connected
NI-DAQ	National Instruments driver software for DAQ hardware
noise	an undesirable electrical signal—Noise comes from external sources such as the AC power line, motors, generators, transformers, fluorescent lights, soldering irons, CRT displays, computers, electrical storms, welders, radio transmitters, and internal sources such as semiconductors, resistors, and capacitors. Noise corrupts signals you are trying to send or receive.

nonreferenced signal sources	signal sources with voltage signals that are not connected to an absolute reference or system ground. Also called floating signal sources. Some common example of nonreferenced signal sources are batteries, transformers, or thermocouples.
NRSE	nonreferenced single-ended mode—all measurements are made with respect to a common (NRSE) measurement system reference, but the voltage at this reference can vary with respect to the measurement system ground
Nyquist frequency	a frequency that is one-half the sampling rate. <i>See</i> Nyquist Sampling Theorem
Nyquist Sampling Theorem	the theorem states that if a continuous bandwidth-limited analog signal contains no frequency components higher than half the frequency at which it is sampled, then the original signal can be recovered without distortion
0	
offset-binary format	a method of digitally encoding sound that represents the range of amplitude values as an unsigned number, with the midpoint of the range representing silence. For example, an 8-bit sound stored in offset-binary format would contain sample values ranging from 0 to 255, with a value of 128 specifying silence (no amplitude). <i>See</i> two's complement format.
onboard channels	channels provided by the plug-in data acquisition device
operating system	base-level software that controls a computer, runs programs, interacts with users, and communicates with installed hardware or peripheral devices
optical isolation	the technique of using an optoelectric transmitter and receiver to transfer data without electrical continuity, to eliminate high-potential differences and transients
oversampling	sampling at a rate greater than the Nyquist frequency

P

passband	the range of frequencies which a device can properly propagate or measure
PCI	Peripheral Component Interconnect—a high-performance expansion bus architecture originally developed by Intel to replace ISA and EISA. It is achieving widespread acceptance as a standard for PCs and work-stations; it offers a theoretical maximum transfer rate of 132 Mbytes/s.
PFI	programmable function input
Plug and Play devices	devices that do not require DIP switches or jumpers to configure resources on the devices—also called switchless devices
port	(1) a communications connection on a computer or a remote controller; (2) a digital port, consisting of four or eight lines of digital input and/or output
posttriggering	the technique used on a DAQ device to acquire a programmed number of samples after trigger conditions are met
ppm	parts per million
pretriggering	the technique used on a DAQ device to keep a continuous buffer filled with data, so that when the trigger conditions are met, the sample includes the data leading up to the trigger condition
pulsed output	a form of counter signal generation by which a pulse is outputted when a counter reaches a certain value

Q

quantization error	the inherent uncertainty in digitizing an analog value due to the finite resolution of the conversion process
quantizer	a device that maps a variable from a continuous distribution to a discrete distribution

R

relative accuracy	a measure in LSB of the linearity of an ADC. It includes all non-linearity and quantization errors. It does not include offset and gain errors of the circuitry feeding the ADC.
resolution	the smallest signal increment that can be detected by a measurement system. Resolution can be expressed in bits, in proportions, or in percent of full scale. For example, a system has 12-bit resolution, one part in 4,096 resolution, and 0.0244% of full scale.
rise time	the difference in time between the 10% and 90% points of the step response of a system
rms	root mean square—the square root of the average value of the square of the instantaneous signal amplitude; a measure of signal amplitude
RSE	<i>See</i> SE.
RTSI bus	real-time system integration bus—the National Instruments timing bus that connects DAQ devices directly, by means of connectors on top of the boards, for precise synchronization of functions

S

s	seconds
S	samples
sample counter	the clock that counts the output of the channel clock, in other words, the number of samples taken. On devices with simultaneous sampling, this counter counts the output of the scan clock and hence the number of scans.
SE	single-ended—a term used to describe an analog input that is measured with respect to a common ground
self-calibrating	a property of a DSA device that has an extremely stable onboard reference and calibrates its own A/D and D/A circuits without manual adjustments by the user
sensor	a device that responds to a physical stimulus (heat, light, sound, pressure, motion, flow, and so on), and produces a corresponding electrical signal
signal conditioning	the manipulation of signals to prepare them for digitizing

SMB	a type of coaxial connector
SNR	signal-to-noise ratio—the ratio of the overall rms signal level to the rms noise level, expressed in decibels
software trigger	a programmed event that triggers an event such as data acquisition
software triggering	a method of triggering in which you simulate an analog trigger using software. Also called conditional retrieval.
source impedance	a parameter of signal sources that reflects current-driving ability of voltage sources (lower is better) and the voltage-driving ability of current sources (higher is better)
S/s	samples per second—used to express the rate at which a DAQ device samples an analog signal
STC	system timing controller
switchless device	devices that do not require dip switches or jumpers to configure resources on the devices—also called Plug and Play devices
synchronous	(1) hardware—a property of an event that is synchronized to a reference clock; (2) software—a property of a function that begins an operation and returns only when the operation is complete
system noise	a measure of the amount of noise seen by an analog circuit or an ADC when the analog inputs are grounded
T	
TC	terminal count—the highest value of a counter
THD	total harmonic distortion—the ratio of the total rms signal due to harmonic distortion to the overall rms signal, in decibel or a percentage
THD+N	signal-to-THD plus noise—the ratio in decibels of the overall rms signal to the rms signal of harmonic distortion plus noise introduced
transducer	<i>See</i> sensor.
transfer rate	the rate, measured in bytes/s, at which data is moved from source to destination after software initialization and set up operations; the maximum rate at which the hardware can operate

TRIG1 (EXT_TRIG)	trigger 1 signal
TRIG2 (PRETRIG)	trigger 2 signal
trigger	any event that causes or starts some form of data capture
tri-state	logic circuitry designed to have three possible outputs—0, 1, and hi-Z. The hi-Z (high impedance) state effectively pulls the output out of its circuit, and can be used to simplify bus communication by wire-ANDing tri-state inputs.
TTL	transistor-transistor logic
TTL-compatible	operating in a nominal range of 0 to 5 VDC, with a signal below 1 V a logic low, and a signal above 2.4 V a logic high
two's complement format	a system for digitally encoding sound that stores the amplitude values as a signed number, with silence represented by a sample with a value of 0. For example, with 8-bit sound samples, two's complement values would range from –128 to 127, with 0 meaning silence. <i>See</i> offset-binary format.

U

undersampling	sampling at a rate lower than the Nyquist frequency—can cause aliasing
update	the output equivalent of a scan. One or more analog or digital output samples. Typically, the number of output samples in an update is equal to the number of channels in the output group. For example, one pulse from the update clock produces one update which sends one new sample to every analog output channel in the group.
UPDATE*	update signal
update rate	the number of output updates per second

V

V	volts
V _{cc}	collector common voltage—power supply voltage
V _{in}	volts in

Glossary

V_{ref}	reference voltage
VDC	volts direct current
VI	virtual instrument—(1) a combination of hardware and/or software elements, typically used with a PC, that has the functionality of a classic stand-alone instrument; (2) a LabVIEW software module (VI), which consists of a front panel user interface and a block diagram program

W

waveform	multiple voltage readings taken at a specific sampling rate
WFTRIG	trigger that initiates waveform generation

Index

Numbers

- +5 V signal
 - analog I/O pin assignments (table)
 - PCI-4451/4452, 4-3
 - PCI-4453/4454, 4-6
 - analog I/O signal summary (table)
 - PCI-4451/4452, 4-4
 - PCI-4453/4454, 4-7
 - analog power connections, 4-16
 - digital I/O pin assignments (table), 4-9
 - digital I/O signal summary (table), 4-11
 - digital power connections, 4-18
 - self-resetting fuse, 4-16, 4-18

A

- AC input coupling, 3-4
- +ACH<0..3> signal
 - analog input signal connections, 4-12 to 4-13
 - analog I/O pin assignments (table)
 - PCI-4451/4452, 4-3
 - PCI-4453/4454, 4-6
 - analog I/O signal summary (table)
 - PCI-4451/4452, 4-4
 - PCI-4453/4454, 4-7
- ACH<0..3> signal
 - analog input signal connections, 4-12 to 4-13
 - analog I/O pin assignments (table), 4-3
 - analog I/O signal summary (table), 4-4
- acquisition timing connections, 4-19 to 4-22
- CONVERT* signal, 4-21
- EXTSTROBE* signal, 4-21 to 4-22
- PFI0/TRIG1 (EXT_TRIG) signal, 4-20
- PFI1/TRIG2 (PRETRIG) signal, 4-21

- typical posttriggered acquisition (figure), 4-19
- typical pretriggered acquisition (figure), 4-20
- ADC, 6-9 to 6-10
- AIGND signal
 - analog input signal connections, 4-12 to 4-13
 - analog I/O pin assignments (table), 4-3
 - analog I/O signal summary (table), 4-4
- AI_SHLD<0..3> signal
 - analog I/O pin assignments (table), 4-6
 - analog I/O signal summary (table), 4-7
- analog cables
 - analog accessories, 1-7
 - custom cabling, 1-6
- analog function block diagram
 - PCI-4451/4452, 3-2
 - PCI-4453/4454, 3-3
- analog input, 3-4 to 3-6
 - input coupling, 3-4
 - input mode, 3-4
 - input polarity and range, 3-4 to 3-6
 - input range selection considerations, 3-5 to 3-6
 - signal connections, 4-12 to 4-13
 - specifications, A-1 to A-6
 - amplifier characteristics, A-3 to A-5
 - channel characteristics, A-1 to A-2
 - dynamic characteristics, A-5 to A-6
 - transfer characteristics, A-2 to A-3
- analog input circuitry, 6-1 to 6-10
 - ADC, 6-9 to 6-10
 - antialias filtering, 6-3 to 6-9
 - calibration, 6-3
 - input coupling, 6-3
 - noise, 6-10

- analog I/O connector signal descriptions
 - pin assignments (table)
 - PCI-4451/4452, 4-3
 - PCI-4453/4454, 4-6
 - pin connections (figure)
 - PCI-4451/4452, 4-2
 - PCI-4453/4454, 4-5
 - signal summary (table)
 - PCI-4451/4452, 4-4
 - PCI-4453/4454, 4-7
- analog operation theory, 6-1 to 6-15
 - analog input circuitry, 6-1 to 6-10
 - ADC, 6-9 to 6-10
 - antialias filtering, 6-3 to 6-9
 - calibration, 6-3
 - input coupling, 6-3
 - noise, 6-10
 - analog output circuitry, 6-11 to 6-15
 - anti-image filtering, 6-12 to 6-13
 - calibration, 6-14
 - DAC, 6-14
 - mute feature, 6-15
- analog output, 3-6 to 3-8
 - output mode, 3-6 to 3-7
 - output polarity and range, 3-7 to 3-8
 - signal connections
 - analog output channel block diagram, 4-15
 - description, 4-14 to 4-16
 - specifications, A-7 to A-9
 - channel characteristics, A-7
 - dynamic characteristics, A-8 to A-9
 - transfer characteristics, A-7
 - voltage output, A-8
- analog output circuitry, 6-11 to 6-15
 - anti-image filtering, 6-12 to 6-13
 - calibration, 6-14
 - DAC, 6-14
 - mute feature, 6-15
- analog power connections, 4-16
- analog trigger, 3-8 to 3-12
 - above-high-level analog triggering mode (figure), 3-9
 - below-low-level analog triggering mode (figure), 3-9
 - high-hysteresis analog triggering mode (figure), 3-10
 - inside-region analog triggering mode (figure), 3-10
 - low-hysteresis analog triggering mode (figure), 3-10
 - specifications, A-10
- antialias filtering, 6-3 to 6-9
 - alias rejection at oversample rate (figure), 6-7
 - clipped or overranged, 6-8 to 6-9
 - comparison of clipped signal to proper signal (figure), 6-9
 - frequency response, 6-6
 - input frequency response (figure), 6-5
 - input frequency response near cutoff (figure), 6-6
 - Nyquist frequency example, 6-3 to 6-4
- anti-image filtering
 - signal spectra in DAC (figure), 6-13
 - theory of operation, 6-12 to 6-13
- AOGND signal
 - analog I/O pin assignments (table), 4-3
 - analog I/O signal summary (table), 4-4
 - analog output signal connections, 4-14 to 4-16
- AO_SHLD<0..1> signal
 - analog I/O pin assignments (table), 4-6
 - analog I/O signal summary (table), 4-7
 - analog output signal connections, 4-16

B

- bipolar input, 3-4 to 3-5
- bipolar output, 3-7

block diagrams
 analog function
 PCI-4451/4452, 3-2
 PCI-4453/4454, 3-3
 analog output channel, 4-15
 digital function, 3-1
 bus interface specifications, A-11

C

cables. *See also* I/O connectors.
 custom cabling, 1-6 to 1-7
 field wiring considerations, 4-28 to 4-29
 optional equipment, 1-5 to 1-6
 calibration, 5-1 to 5-3
 external calibration, 5-2 to 5-3
 loading calibration constants, 5-1 to 5-2
 onboard calibration reference
 specifications, A-6
 self-calibration, 5-2
 specifications, A-12
 theory of operation
 analog input circuitry, 6-3
 analog output circuitry, 6-14
 traceable recalibration, 5-3
 CGND signal
 analog I/O pin assignments (table), 4-6
 analog I/O signal summary (table), 4-7
 clocks, device and RTSI, 3-14
 ComponentWorks software, 1-4
 configuration
 device configuration, 2-2
 effect of sampling and update rates, 3-15
 connectors. *See* I/O connectors.
 conventions used in manual, xi-xii
 CONVERT* signal
 digital I/O pin assignments (table), 4-9
 digital I/O signal summary (table), 4-11
 timing connections, 4-21

custom cables
 analog accessories, 1-7
 analog cables, 1-6
 digital cables, 1-7

D

DAC
 mute feature, 6-15
 signal spectra in DAC (figure), 6-13
 theory of operation, 6-14
 +DAC0OUT signal
 analog I/O pin assignments (table)
 PCI-4451/4452, 4-3
 PCI-4453/4454, 4-6
 analog I/O signal summary (table)
 PCI-4451/4452, 4-4
 PCI-4453/4454, 4-7
 analog output signal connections,
 4-14 to 4-16
 -DAC0OUT signal
 analog I/O pin assignments (table), 4-3
 analog I/O signal summary (table), 4-4
 analog output signal connections,
 4-14 to 4-15
 +DAC1OUT signal
 analog I/O pin assignments (table)
 PCI-4451/4452, 4-3
 PCI-4453/4454, 4-6
 analog I/O signal summary (table)
 PCI-4451/4452, 4-4
 PCI-4453/4454, 4-7
 analog output signal connections,
 4-14 to 4-16
 -DAC1OUT signal
 analog I/O pin assignments (table), 4-3
 analog I/O signal summary (table), 4-4
 analog output signal connections,
 4-14 to 4-15
 data acquisition timing connections. *See*
 acquisition timing connections.

- DC input coupling, 3-4
 - DDS (direct digital synthesis)
 - technology, 3-14
 - delta-sigma converters
 - configuration issues, 3-15
 - triggering effect, 3-8
 - delta-sigma modulation
 - analog input circuitry, 6-9
 - analog output circuitry, 6-11
 - device configuration
 - requirements, 2-2
 - sampling rate and undersampling, 3-15
 - DGND signal
 - analog I/O pin assignments (table)
 - PCI-4451/4452, 4-3
 - PCI-4453/4454, 4-6
 - analog I/O signal summary (table)
 - PCI-4451/4452, 4-4
 - PCI-4453/4454, 4-7
 - digital I/O pin assignments (table), 4-9
 - digital I/O signal connections, 4-17
 - digital I/O signal summary (table), 4-11
 - timing connections, 4-18
 - diagnostic resources, online, C-C-1
 - DIFF input mode, 3-4
 - DIFF output mode, 3-6
 - digital cables for PCI-4451/4452, 1-7
 - digital function (block diagram), 3-1
 - digital I/O
 - high impedance state (note), 3-12
 - overview, 3-12 to 3-13
 - signal connections, 4-17
 - specifications, A-9
 - digital I/O signal descriptions
 - pin assignments (table), 4-9 to 4-10
 - pin connections (figure), 4-8
 - signal summary (table), 4-11
 - digital power connections, 4-18
 - digital trigger specifications, A-10
 - DIO<0..7> signal
 - digital I/O pin assignments (table), 4-9
 - digital I/O signal connections, 4-17
 - digital I/O signal summary (table), 4-11
 - direct digital synthesis (DDS)
 - technology, 3-14
 - documentation
 - conventions used in manual, *xi-xii*
 - how to use manual set, *xi*
 - related documentation, *xii*
- ## E
- EEPROM storage of calibration constants, 5-1
 - environment specifications, A-12
 - environmental noise, avoiding, 4-28 to 4-29, 6-10
 - equipment, optional, 1-5 to 1-6
 - EXTSTROBE* signal
 - digital I/O pin assignments (table), 4-9
 - digital I/O signal summary (table), 4-11
 - timing connections, 4-21 to 4-22
- ## F
- field wiring considerations, 4-28 to 4-29
 - floating signal sources, 4-14
 - FREQ_OUT signal
 - digital I/O pin assignments (table), 4-10
 - digital I/O signal summary (table), 4-11
 - general-purpose timing connections, 4-28
 - fuse, self-resetting
 - analog power connections, 4-16
 - digital power connections, 4-18
- ## G
- general-purpose timing signal connections, 4-22 to 4-28
 - FREQ_OUT signal, 4-28
 - GPCTRO_GATE signal, 4-23 to 4-24

GPCTR0_OUT signal, 4-24
 GPCTR0_SOURCE signal, 4-23
 GPCTR0_UP_DOWN signal, 4-24
 GPCTR1_GATE signal, 4-25
 GPCTR1_OUT signal, 4-26
 GPCTR1_SOURCE signal, 4-24 to 4-25
 GPCTR1_UP_DOWN signal,
 4-26 to 4-28
 GPCTR0_GATE signal, 4-23 to 4-24
 GPCTR0_OUT signal
 digital I/O pin assignments (table), 4-10
 digital I/O signal summary (table), 4-11
 general-purpose timing connections, 4-24
 GPCTR0_SOURCE signal, 4-23
 GPCTR0_UP_DOWN signal, 4-24
 GPCTR1_GATE signal, 4-25
 GPCTR1_OUT signal
 digital I/O pin assignments (table), 4-10
 digital I/O signal summary (table), 4-11
 general-purpose timing connections, 4-26
 GPCTR1_SOURCE signal, 4-24 to 4-25
 GPCTR1_UP_DOWN signal, 4-26 to 4-28
 ground-referenced signal sources, 4-14

H

hardware installation, 2-1 to 2-2
 hardware overview
 analog input, 3-4 to 3-6
 input mode, 3-4
 input polarity and range, 3-4 to 3-6
 input range selection considerations,
 3-5 to 3-6
 analog output, 3-6 to 3-8
 analog trigger, 3-8 to 3-12
 block diagrams
 analog function, 3-2 to 3-3
 digital function, 3-1
 digital I/O, 3-12 to 3-13

timing signal routing, 3-13 to 3-14
 device and RTSI clocks, 3-14
 programmable function inputs, 3-13

I

input coupling
 analog input, 3-4
 theory of operation, 6-3
 input mode, 3-4
 input polarity and range, 3-4 to 3-6
 actual range and measurement precision
 (table), 3-5
 exceeding rated input voltages
 (caution), 3-6
 selection considerations, 3-5 to 3-6
 installation
 hardware, 2-1 to 2-2
 software, 2-1
 unpacking PCI-445X, 1-3
 I/O connectors, 4-1 to 4-11
 exceeding maximum ratings
 (warning), 4-1
 pin assignments (table)
 analog I/O, 4-3, 4-6
 digital I/O, 4-9 to 4-10
 pin connections
 68-pin digital connector (figure), B-2
 analog I/O (figure), 4-2, 4-5
 DB-25 pinout for SHC68-DB25
 cable (figure), B-1
 digital (figure), 4-8
 signal summary (table)
 analog I/O, 4-4, 4-7
 digital I/O, 4-11

J

jitter, with triggering, 3-8 to 3-9

L

LabVIEW and LabWindows/CVI application software, 1-3 to 1-4

M

manual. *See* documentation.

Measure software, 1-4

mute feature, 6-15

N

National Instruments Web support, C-1 to C-2

NI-DAQ driver software, 1-4 to 1-5

noise, avoiding, 4-28 to 4-29, 6-10

Nyquist frequency, 6-3 to 6-4

O

onboard calibration reference specifications, A-6

online problem-solving and diagnostic resources, C-1

optional equipment, 1-5 to 1-6

output mode, 3-6

output polarity and range, 3-7 to 3-8

 actual range and measurement precision (table), 3-7

 boot modes (note), 3-8

P

PCI-445X. *See also* hardware overview.

 custom cabling, 1-6 to 1-7

 installation and configuration, 2-1 to 2-2

 optional equipment, 1-5 to 1-6

 overview, 1-1

 requirements for getting started, 1-2

 software programming choices, 1-3 to 1-5

 National Instruments application software, 1-4 to 1-5

 NI-DAQ driver software, 1-4 to 1-5

 unpacking, 1-3

PFI0/TRIG1 (EXT_TRIG) signal

 digital I/O pin assignments (table), 4-9

 digital I/O signal summary (table), 4-11

 timing connections, 4-20

PFI1/TRIG2 (PRETRIG) signal

 digital I/O pin assignments (table), 4-9

 digital I/O signal summary (table), 4-11

 timing connections, 4-21

PFI3/GPCTR1_SOURCE signal

 digital I/O pin assignments (table), 4-9

 digital I/O signal summary (table), 4-11

PFI4/GPCTR1_GATE signal

 digital I/O pin assignments (table), 4-10

 digital I/O signal summary (table), 4-11

PFI6/WFTRIG signal

 digital I/O pin assignments (table), 4-10

 digital I/O signal summary (table), 4-11

PFI7 signal

 digital I/O pin assignments (table), 4-10

 digital I/O signal summary (table), 4-11

PFI8/GPCTR0_SOURCE signal

 digital I/O pin assignments (table), 4-10

 digital I/O signal summary (table), 4-11

PFI9/GPCTR0_GATE signal

 digital I/O pin assignments (table), 4-10

 digital I/O signal summary (table), 4-11

PFIIs (programmable function inputs)

 overview, 4-19

 signal routing, 3-13

 timing input connections, 4-19

physical specifications, A-12

pin assignments

 analog I/O (table)

 PCI-4451/4452, 4-3

 PCI-4453/4454, 4-6

 digital I/O (table), 4-9 to 4-10

- pin connections (figure)
 - 68-pin digital connector (figure), B-2
 - analog I/O
 - PCI-4451/4452, 4-2
 - PCI-4453/4454, 4-5
 - DB-25 pinout for SHC68-DB25 cable (figure), B-1
 - digital I/O, 4-8
- polarity selection
 - analog input, 3-4 to 3-6
 - actual range and measurement precision (table), 3-5
 - selection considerations, 3-5 to 3-6
 - analog output, 3-7 to 3-8
- posttriggered data acquisition, 4-19
- power connections
 - analog power connections, 4-16
 - digital power connections, 4-18
- power requirement specifications, A-11 to A-12
- pretriggered data acquisition, 4-20
- problem-solving and diagnostic resources, online, C-1
- programmable function inputs (PFIs). *See* PFIs (programmable function inputs).

R

- recalibration, traceable, 5-3
- requirements for getting started, 1-2
- RESERVED1 signal
 - digital I/O pin assignments (table), 4-9
 - digital I/O signal summary (table), 4-11
- RTSI bus signal connection (figure), 3-12
- RTSI clocks, 3-14
- RTSI trigger lines
 - overview, 3-12
 - signal connection (figure), 3-12

S

- sample rate, and device configuration, 3-15
- sample/update clock frequency, selecting, 3-14 to 3-15
- signal connections
 - analog input, 4-12 to 4-13
 - digital I/O, 4-17
 - field wiring considerations, 4-28 to 4-29
 - I/O connectors, 4-1 to 4-11
 - 68-pin digital connector pin connections (figure), B-2
 - analog I/O pin assignments (table), 4-3, 4-6
 - analog I/O pin connections (figure), 4-2, 4-5
 - analog I/O signal summary (table), 4-4, 4-7
 - DB-25 pinout for SHC68-DB25 cable (figure), B-1
 - digital I/O pin assignments (table), 4-9 to 4-10
 - digital I/O pin connections (figure), 4-8
 - digital I/O signal summary (table), 4-11
 - exceeding maximum ratings (warning), 4-1
 - power connections, 4-16
 - timing connections, 4-18 to 4-28
 - acquisition timing connections, 4-19 to 4-22
 - general-purpose timing signal connections, 4-22 to 4-28
 - programmable function input connections, 4-19
 - waveform generation timing connections, 4-22
- types of signal sources, 4-14
 - floating, 4-14
 - ground-referenced, 4-14

- software installation, 2-1
- software programming choices, 1-3 to 1-5
 - ComponentWorks, 1-4
 - LabVIEW and LabWindows/CVI application software, 1-3 to 1-4
 - Measure, 1-4
 - National Instruments application software, 1-3 to 1-4
 - NI-DAQ driver software, 1-4 to 1-5
 - VirtualBench, 1-4
- software-related resources, C-2
- specifications
 - analog input, A-1 to A-6
 - amplifier characteristics, A-3 to A-5
 - channel characteristics, A-1 to A-2
 - dynamic characteristics, A-5 to A-6
 - transfer characteristics, A-2 to A-3
 - analog output, A-7 to A-9
 - channel characteristics, A-7
 - dynamic characteristics, A-8 to A-9
 - transfer characteristics, A-7
 - voltage output, A-8
 - analog trigger, A-10
 - bus interface, A-11
 - calibration, A-12
 - digital I/O, A-9
 - digital trigger, A-10
 - environment, A-12
 - onboard calibration reference, A-6
 - physical, A-12
 - power requirements, A-11 to A-12
 - timing I/O, A-9 to A-10

T

- technical support resources, C-1 to C-2
- theory of operation. *See* analog operation theory.

- timing connections, 4-18 to 4-28
 - acquisition timing connections, 4-19 to 4-22
 - CONVERT* signal, 4-21
 - EXTSTROBE* signal, 4-21 to 4-22
 - PFI0/TRIG1 (EXT_TRIG) signal, 4-20
 - PFI1/TRIG2 (PRETRIG) signal, 4-21
 - typical posttriggered acquisition (figure), 4-19
 - typical pretriggered acquisition (figure), 4-20
 - general-purpose timing signal connections, 4-22 to 4-28
 - FREQ_OUT signal, 4-28
 - GPCTR0_GATE signal, 4-23 to 4-24
 - GPCTR0_OUT signal, 4-24
 - GPCTR0_SOURCE signal, 4-23
 - GPCTR0_UP_DOWN signal, 4-24
 - GPCTR1_GATE signal, 4-25
 - GPCTR1_OUT signal, 4-26
 - GPCTR1_SOURCE signal, 4-24 to 4-25
 - GPCTR1_UP_DOWN signal, 4-26 to 4-28
 - programmable function input connections, 4-19
 - waveform generation timing connections, 4-22
 - UPDATE* signal, 4-22
 - WFTRIG signal, 4-22
- timing I/O specifications, A-9 to A-10
- timing signal routing, 3-13 to 3-14
 - device and RTSI clocks, 3-14
 - programmable function inputs, 3-13
- traceable recalibration, 5-3

triggers

- analog, 3-8 to 3-12
 - above-high-level triggering mode (figure), 3-9
 - below-low-level triggering mode (figure), 3-9
 - high-hysteresis triggering mode, 3-10
 - inside-region triggering mode (figure), 3-10
 - low-hysteresis triggering mode, 3-10
- specifications, A-10
- digital, specifications, A-10
- RTSI triggers, 3-12
- specifications, A-10

U

- unpacking PCI-445X, 1-3
- update clock frequency, selecting, 3-14 to 3-15
- update rate, and device configuration, 3-15
- UPDATE* signal
 - digital I/O pin assignments (table), 4-10
 - digital I/O signal summary (table), 4-11
 - timing connections, 4-22

V

- VirtualBench software, 1-4
- voltage output specifications, A-8

W

- waveform generation timing connections, 4-22
 - UPDATE* signal, 4-22
 - WFTRIG signal, 4-22
- Web support from National Instruments, C-1 to C-2
 - online problem-solving and diagnostic resources, C-1
 - software-related resources, C-2
- WFTRIG signal, 4-22
- wiring considerations, 4-28 to 4-29
- Worldwide technical support, C-2