

## COMPREHENSIVE SERVICES

We offer competitive repair and calibration services, as well as easily accessible documentation and free downloadable resources.

## SELL YOUR SURPLUS

We buy new, used, decommissioned, and surplus parts from every NI series. We work out the best solution to suit your individual needs.

 Sell For Cash    Get Credit    Receive a Trade-In Deal

## OBSOLETE NI HARDWARE IN STOCK & READY TO SHIP

We stock **New**, **New Surplus**, **Refurbished**, and **Reconditioned** NI Hardware.



*Bridging the gap between the manufacturer and your legacy test system.*

 1-800-915-6216

 [www.apexwaves.com](http://www.apexwaves.com)

 [sales@apexwaves.com](mailto:sales@apexwaves.com)

*All trademarks, brands, and brand names are the property of their respective owners.*

**Request a Quote**

 **CLICK HERE**

**PCMCIA-485**

# Serial Quick Reference Guide

## 10-Position Modular Jack

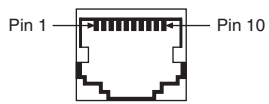

| Pin | 232              | 422/485     |
|-----|------------------|-------------|
| 1   | No Connect       | No Connect  |
| 2   | RI <sup>1</sup>  | TXD-        |
| 3   | CTS              | TXD+        |
| 4   | RTS              | RTS- (HSO-) |
| 5   | DSR <sup>1</sup> | CTS- (HSI-) |
| 6   | GND              | RXD-        |
| 7   | DTR <sup>1</sup> | RXD+        |
| 8   | TXD              | RTS+ (HSO+) |
| 9   | RXD              | CTS+ (HSI+) |
| 10  | DCD <sup>1</sup> | GND         |

<sup>1</sup> These signals are "No Connect" on the PCI-2321 and PXI-8422 ports.

## DB-9 Male



| Pin | 232 DTE          | 232 DCE | 422/485     |
|-----|------------------|---------|-------------|
| 1   | DCD <sup>2</sup> | DCD     | GND         |
| 2   | RXD              | TXD     | CTS+ (HSI+) |
| 3   | TXD              | RXD     | RTS+ (HSO+) |
| 4   | DTR <sup>2</sup> | DSR     | RXD+        |
| 5   | GND              | GND     | RXD-        |
| 6   | DSR <sup>2</sup> | DTR     | CTS- (HSI-) |
| 7   | RTS              | CTS     | RTS- (HSO-) |
| 8   | CTS              | RTS     | TXD+        |
| 9   | RI <sup>2</sup>  | RI      | TXD-        |

**Note:** DCE mode supported on USB-232/2 and USB-232/4 only.

<sup>2</sup> These signals are "No Connect" on the PCI-2321 and PXI-8422 ports and ports 9-16 on legacy 16-port boards.

## DB-25 Male

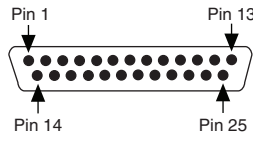

| Pin | 232              | 422/485     |
|-----|------------------|-------------|
| 2   | TXD              | RTS+ (HSO+) |
| 3   | RXD              | CTS+ (HSI+) |
| 4   | RTS              | RTS- (HSO-) |
| 5   | CTS              | TXD+        |
| 6   | DSR <sup>3</sup> | CTS- (HSI-) |
| 7   | GND              | RXD-        |
| 8   | DCD <sup>3</sup> | GND         |
| 20  | DTR <sup>3</sup> | RXD+        |
| 22  | RI <sup>3</sup>  | TXD-        |

Pins not listed in this table are "No Connect."

<sup>3</sup> These signals are "No Connect" on the PCI-2321 and PXI-8422 ports.

## RS-232 Loopback

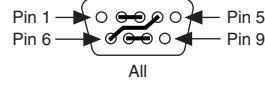
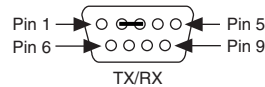

## RS-485/422 Loopback

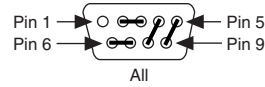
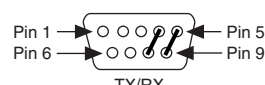

## RS-232 Signals

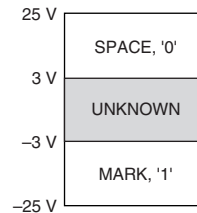

## RS-485/422 Signals

If '-' < '+'  
then MARK, '1'

If '-' > '+'  
then SPACE, '0'

RS-422 Voltage: ±7 V

RS-485 Voltage:  
-7 V to +12 V

## UART Data Frame Example

0xD9—8 Data Bits, Odd Parity, 1 Stop Bit

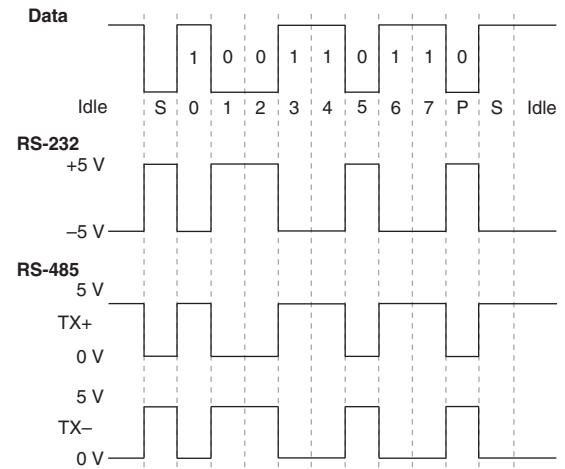

Voltagess are for illustration only. Actual voltage levels may vary.

## RS-485 Topologies

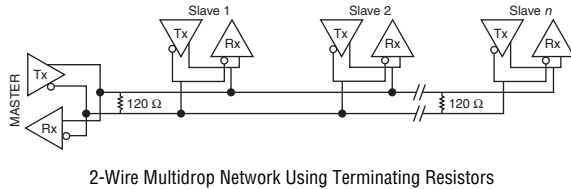

2-Wire Multidrop Network Using Terminating Resistors

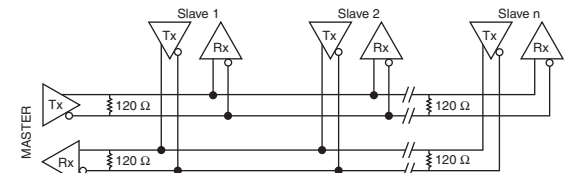

4-Wire Full-Duplex Multidrop Network Using Terminating Resistors

RS-485 terminators are available at [ni.com/serial](http://ni.com/serial).

## RS-485 Transceiver Control

| Enable | 4-Wire | 2-Wire   |             |      |
|--------|--------|----------|-------------|------|
|        |        | DTR/Echo | DTR/No Echo | Auto |
| TX     | ON     | DTR      | DTR         | TX   |
| RX     | ON     | ON       | DTR         | TX   |

## LabVIEW Programming Example

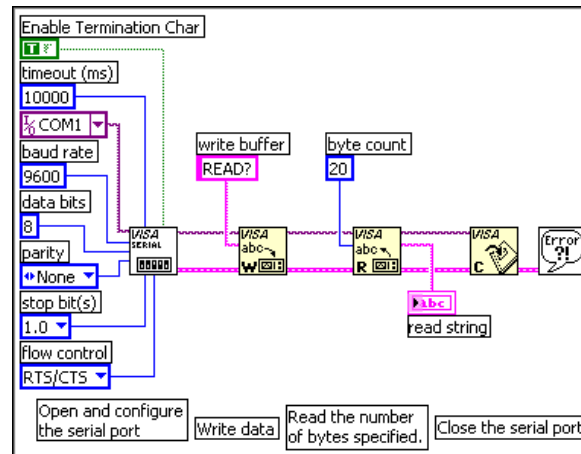

For more information about LabVIEW, refer to [ni.com/labview](http://ni.com/labview).

## NI-Serial Features

### Hardware

- Flexible baud rates up to 3 Mb/s
- High-performance DMA engine
- Isolation up to 2000 V
- RS-485 transceiver control

### Software

- Deterministic control with LabVIEW Real-Time
- Over 3000 instrument drivers online
- Powerful development tools

For more information about NI Serial products, refer to [ni.com/serial](http://ni.com/serial).

## ASCII Table

| Dec | Hex  | Char  | Dec | Hex  | Char | Dec | Hex  | Char | Dec | Hex  | Char  |
|-----|------|-------|-----|------|------|-----|------|------|-----|------|-------|
| 0   | 0x00 | (nul) | 32  | 0x20 | (sp) | 64  | 0x40 | @    | 96  | 0x60 | '     |
| 1   | 0x01 | (soh) | 33  | 0x21 | !    | 65  | 0x41 | A    | 97  | 0x61 | a     |
| 2   | 0x02 | (stx) | 34  | 0x22 | "    | 66  | 0x42 | B    | 98  | 0x62 | b     |
| 3   | 0x03 | (etx) | 35  | 0x23 | #    | 67  | 0x43 | C    | 99  | 0x63 | c     |
| 4   | 0x04 | (eot) | 36  | 0x24 | \$   | 68  | 0x44 | D    | 100 | 0x64 | d     |
| 5   | 0x05 | (enq) | 37  | 0x25 | %    | 69  | 0x45 | E    | 101 | 0x65 | e     |
| 6   | 0x06 | (ack) | 38  | 0x26 | &    | 70  | 0x46 | F    | 102 | 0x66 | f     |
| 7   | 0x07 | (bel) | 39  | 0x27 | '    | 71  | 0x47 | G    | 103 | 0x67 | g     |
| 8   | 0x08 | (bs)  | 40  | 0x28 | (    | 72  | 0x48 | H    | 104 | 0x68 | h     |
| 9   | 0x09 | (tab) | 41  | 0x29 | )    | 73  | 0x49 | I    | 105 | 0x69 | i     |
| 10  | 0x0A | (lf)  | 42  | 0x2A | *    | 74  | 0x4A | J    | 106 | 0x6A | j     |
| 11  | 0x0B | (vt)  | 43  | 0x2B | +    | 75  | 0x4B | K    | 107 | 0x6B | k     |
| 12  | 0x0C | (ff)  | 44  | 0x2C | ,    | 76  | 0x4C | L    | 108 | 0x6C | l     |
| 13  | 0x0D | (cr)  | 45  | 0x2D | -    | 77  | 0x4D | M    | 109 | 0x6D | m     |
| 14  | 0x0E | (so)  | 46  | 0x2E | .    | 78  | 0x4E | N    | 110 | 0x6E | n     |
| 15  | 0x0F | (si)  | 47  | 0x2F | /    | 79  | 0x4F | O    | 111 | 0x6F | o     |
| 16  | 0x10 | (dle) | 48  | 0x30 | 0    | 80  | 0x50 | P    | 112 | 0x70 | p     |
| 17  | 0x11 | (dc1) | 49  | 0x31 | 1    | 81  | 0x51 | Q    | 113 | 0x71 | q     |
| 18  | 0x12 | (dc2) | 50  | 0x32 | 2    | 82  | 0x52 | R    | 114 | 0x72 | r     |
| 19  | 0x13 | (dc3) | 51  | 0x33 | 3    | 83  | 0x53 | S    | 115 | 0x73 | s     |
| 20  | 0x14 | (dc4) | 52  | 0x34 | 4    | 84  | 0x54 | T    | 116 | 0x74 | t     |
| 21  | 0x15 | (nak) | 53  | 0x35 | 5    | 85  | 0x55 | U    | 117 | 0x75 | u     |
| 22  | 0x16 | (syn) | 54  | 0x36 | 6    | 86  | 0x56 | V    | 118 | 0x76 | v     |
| 23  | 0x17 | (etb) | 55  | 0x37 | 7    | 87  | 0x57 | W    | 119 | 0x77 | w     |
| 24  | 0x18 | (can) | 56  | 0x38 | 8    | 88  | 0x58 | X    | 120 | 0x78 | x     |
| 25  | 0x19 | (em)  | 57  | 0x39 | 9    | 89  | 0x59 | Y    | 121 | 0x79 | y     |
| 26  | 0x1A | (sub) | 58  | 0x3A | :    | 90  | 0x5A | Z    | 122 | 0x7A | z     |
| 27  | 0x1B | (esc) | 59  | 0x3B | ;    | 91  | 0x5B | [    | 123 | 0x7B | {     |
| 28  | 0x1C | (fs)  | 60  | 0x3C | <    | 92  | 0x5C | \    | 124 | 0x7C |       |
| 29  | 0x1D | (gs)  | 61  | 0x3D | =    | 93  | 0x5D | ]    | 125 | 0x7D | }     |
| 30  | 0x1E | (rs)  | 62  | 0x3E | >    | 94  | 0x5E | ^    | 126 | 0x7E | ~     |
| 31  | 0x1F | (us)  | 63  | 0x3F | ?    | 95  | 0x5F | _    | 127 | 0x7F | (del) |

For more information about NI products, refer to [ni.com](http://ni.com).

Refer to the *NI Trademarks and Logo Guidelines* at [ni.com/trademarks](http://ni.com/trademarks) for more information on National Instruments trademarks. Other product and company names mentioned herein are trademarks or trade names of their respective companies. For patents covering National Instruments products/technology, refer to the appropriate location: **Help»Patents** in your software, the `patents.txt` file on your media, or the *National Instruments Patents Notice* at [ni.com/patents](http://ni.com/patents). You can find information about end-user license agreements (EULAs) and third-party legal notices in the readme file for your NI product. Refer to the *Export Compliance Information* at [ni.com/legal/export-compliance](http://ni.com/legal/export-compliance) for the National Instruments global trade compliance policy and how to obtain relevant HTS codes, ECCNs, and other import/export data.

