

Last Revised: 2014-11-06 07:14:08.0

2.66 GHz Dual-Core Embedded Controller for PXI

NI PXI-8109



- Intel Core i7-620M dual-core processor (2.66 GHz (base), 3.33 (single-core turbo))
- 2 GB (1 x 2 GB DIMM) dual-channel 1066 MHz DDR3 standard, 8 GB (2 x 4 GB DIMM) maximum
- Up to 132 MB/s system and slot bandwidth
- High-performance 7200 rpm integrated hard drive with standard option
- Two 10/100/1000BASE-TX Ethernet ports and four Hi-Speed USB ports
- Other peripherals (ExpressCard/34 slot, DVI-I video connector, IEEE 1284 ECP/EPP parallel port, GPIB (IEEE 488) controller, and RS232 serial port)
- Software - OS and drivers already installed and hard-drive-based recovery image
- Complete PXI system configuration at ni.com/pxiadvisor

Overview

The NI PXI-8109 is a high-performance Intel Core i7-620M processor-based embedded controller for PXI systems. With the 2.66 GHz base frequency, 3.33 GHz (single-core turbo) dual-core processor, and dual-channel 1066 MHz DDR3 memory, the PXI-8109 is ideal for processor-intensive, modular instrumentation, and data acquisition applications.

[Back to Top](#)

Requirements and Compatibility

OS Information

- Windows 7 32-bit
- Windows 7 64-bit
- Windows XP

[Back to Top](#)

Application and Technology

NI PXI-8109 Features

CPU	Intel Core i7-620M, 2.66 GHz (base), 3.33 GHz (single-core turbo mode), 3.06 GHz (dual-core turbo mode) ¹
L2 cache	256 KB x2 (256 KB per core)
L3 cache	4 MB shared Intel smart cache
Dual-channel 1066 MHz DDR3 RAM, standard	2 GB (1 x 2 GB)
Dual-channel 1066 MHz DDR3 RAM, maximum	8 GB (2 x 4 GB)
Hard drive (standard option), minimum	120 GB SATA (7200 rpm)
Hard drive (extended temperature and 24/7 option), minimum	80 GB SATA (5400 rpm)

10/100/1000BASE-TX (Gigabit) Ethernet ports	2
Hi-Speed USB ports	4
GPIO (IEEE 488) controller	
Serial port (RS232)	
Parallel port	
ExpressCard/34 slot	
Watchdog/trigger SMB	
Installed OS ²	Windows 7 Professional, Windows XP Professional SP3 for Embedded Systems ³

¹ Processor should not throttle CPU frequency under reasonable, worst-case processor workloads in high operating temperature.

² Contact National Instruments or visit ni.com/pxiadvisor for information on other available operating systems.

³ Windows XP Pro for Embedded Systems contains the same software bits and operates identically to Windows XP Pro. The main difference is the licensing that is used for Windows XP Pro for Embedded Systems.

Due to the [Microsoft support life cycle](#) for Windows XP, National Instruments will be unable to provide PXI embedded controllers with Windows XP preinstalled after 2015. View the [Microsoft support life cycle](#) for full details about Windows XP end of life for OEM partners.

Table 1. NI PXI-8109 Features

Dual-Core Processor

The PXI-8109 includes the dual-core Intel Core i7-620M processor. Dual-core processors contain two cores, or computing engines, in one physical package. To increase the number of threads that can be processed, the PXI-8109 uses Intel Hyper-Threading technology that takes each of the two physical cores available and splits them into two virtual cores, for a total of four virtual cores. These four virtual cores can execute four computing tasks, which is advantageous in multitasking environments such as Windows 7. Multithreaded system development environments, such as NI LabVIEW, can take full advantage of the available processing cores on the PXI-8109 by automatically separating their tasks into independent threads. Figure 1 compares the SYSmark 2007 overall performance of the PXI-8109 controller with other PXI embedded controllers.

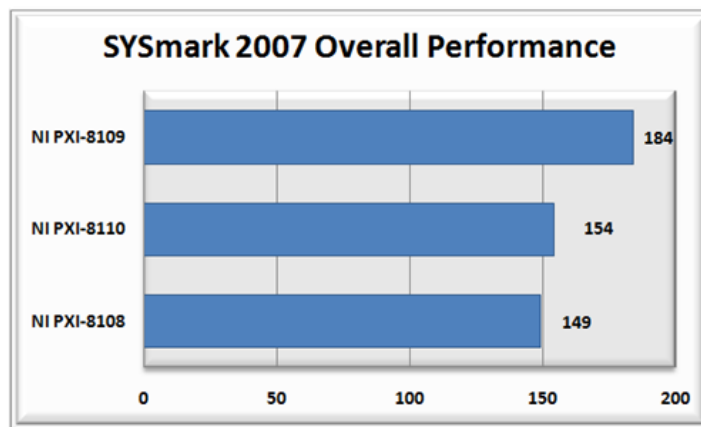

Figure 1. Embedded Controller Benchmarks

Previously, to fully exercise the two physical cores on the PXI-8109, applications had to be architected to create two independent execution threads by implementing programming strategies such as task parallelism, data parallelism, and pipelining. However, Intel introduced Turbo Boost technology to provide performance benefits for all types of applications without requiring the application to be optimized for multicore processors. The PXI-8109 has a 2.66 GHz base clock frequency, and, with Intel Turbo Boost technology, the frequency automatically increases based on the application type. For example, when running applications that generate only a single processing thread, the CPU places the one unused core into an idle state and increases the active core's clock frequency from 2.66 to 3.33 GHz.¹ For applications that are processing two threads, the CPU increases the active core's clock frequency from 2.66 to 3.06 GHz.¹ Turbo Boost provides performance increases for all types of applications and can significantly reduce test times for applications that are processor-intensive.

¹Processor should not throttle CPU frequency under reasonable, worst-case processor workloads in high operating temperatures.

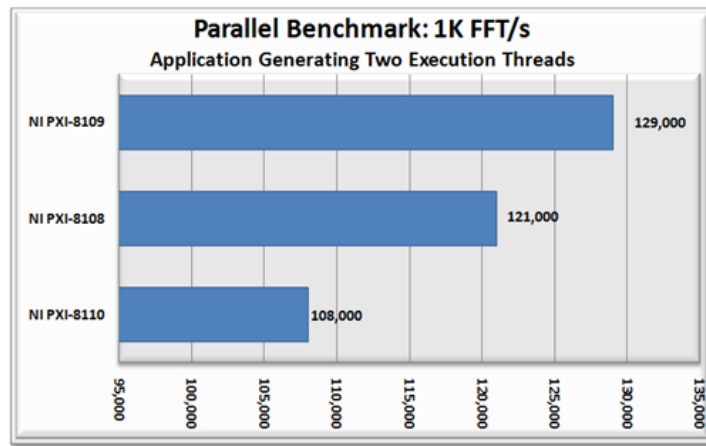

Figure 2. The PXI-8109 can process 129,000 1K FFTs per second, which is about 20 percent faster than the NI PXI-8110 embedded controller.

Hardware

With state-of-the-art packaging, the PXI-8109 integrates the Intel Core i7-620M processor and all standard and extended PC I/O ports into a single unit. Because many of the I/O ports on the controller are integrated, all active slots in the chassis remain available for measurement and control modules. This rugged one-piece controller design minimizes integration issues and eliminates the need for complex cabling to daughterboards. The PXI-8109 block diagram is shown in Figure 3.

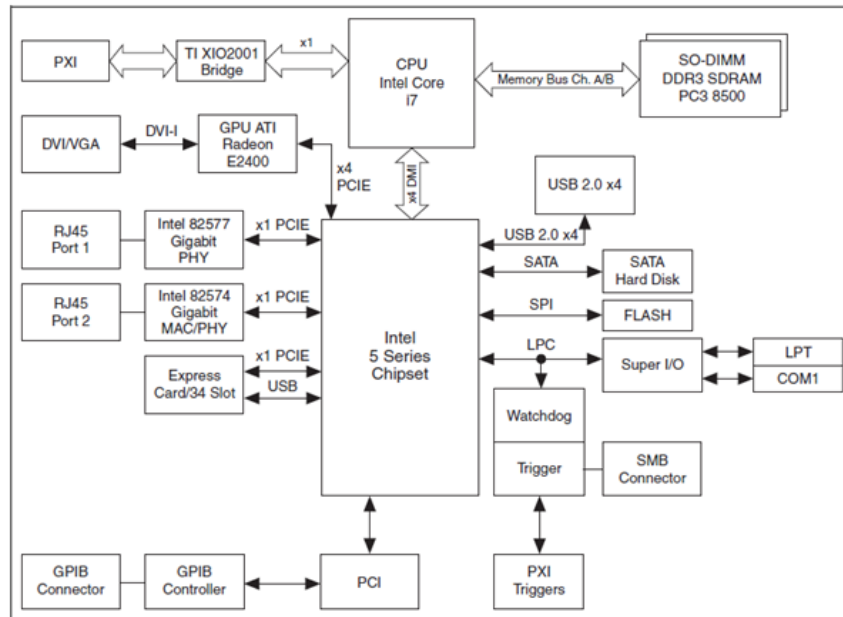

Figure 3. PXI-8109 Block Diagram

Peripheral I/O

This module includes high-performance peripheral I/O such as two 10/100/1000BASE-TX (Gigabit) Ethernet ports and four Hi-Speed USB ports for connection to a keyboard, mouse, CD-ROM/DVD-ROM drive for software installation, or other standard PC peripherals such as speakers, printers, or memory sticks. Use the IEEE 1284 ECP/EPP parallel port to connect to a wide variety of devices, including tape backup drives and printers. An RS232 port is available for connecting to serial devices. Additionally, the PXI-8109 controller includes an integrated GPIB (IEEE 488) controller, which provides control of external instrumentation, saving additional cost and a slot.

In-ROM Memory and Hard-Drive Diagnostics

To improve the serviceability of the NI PXI-8109, In-ROM diagnostics for the hard drive and memory can be quickly accessed without requiring external third-party tools. By running these diagnostics, the results of analysis can determine if replacement of the hard drive or memory is required. The design of the controller allows for quick field replacement of critical components such as the hard drive and the memory without affecting the warranty. To ease the process of buying spare components, you can purchase hard drive and memory upgrades with the NI PXI-8109. The combination of this and the In-ROM diagnostics significantly improves NI PXI-8109 serviceability.

ExpressCard

This embedded controller features an ExpressCard/34 slot. ExpressCard uses the PCI Express and Hi-Speed USB serial interfaces to provide up to 2.5 Gbit/s of bidirectional throughput. Use the ExpressCard/34 slot to add a third Gigabit Ethernet port to your system or additional peripheral I/O such as external hard drives, RAID arrays, 802.11 wireless LAN, IEEE 1394, Bluetooth, or various memory adapters.

Video

The PXI-8109 includes an integrated ATI Radeon E2400 graphics processing unit, which delivers intense, realistic 3D graphics with sharp images, fast rendering, smooth motion, and high detail, without the need for an additional video card or peripheral. This unique architecture provides balanced memory usage between graphics and the system for optimal performance. Additionally, the PXI-8109 features a DVI-I video connector that is compatible with digital (DVI) and analog video (VGA) monitors. A DVI-I to VGA adapter is included with the controller for use with VGA monitors.

Dual Monitor Support

The DVI-I video port on the PXI-8109 is capable of supporting simultaneous DVI and VGA output. With this built-in capability, you can connect a digital and an analog monitor or

two analog monitors to your PXI system at the same time with independent displays. This negates the need for a separate PXI or CompactPCI video module to connect two monitors to your PXI system. A DVI-I (male) to DVI-D (female) and VGA (female) splitter is required for connecting the two monitors and is available from National Instruments (part number 780868-01).

Memory

The PXI-8109 uses dual-channel 1066 MHz DDR3 SDRAM, which makes the controller ideal for data-intensive applications requiring significant analysis. It has two SO-DIMM sockets for the DDR3 SDRAM. 2 GB (1 x 2 GB DIMM) of RAM is standard with upgrade options to 8 GB.

Memory Options	Configuration	Part Number	
		Included in Kit	Additional P/N Required
Standard - 2 GB	1 x 2 GB DIMM	1 x 2 GB DIMM	N/A
4 GB	2 x 2 GB DIMM	1 x 2 GB DIMM	Add 1 x 781508-2048
6 GB	1 x 2 GB DIMM and 1 x 4 GB DIMM	1 x 2 GB DIMM	Add 1 x 781509-4096
8 GB	2 x 4 GB DIMM	N/A	Add 2 x 781509-4096

Table 2. Memory Upgrade Options

Extended Temperature and 24/7 Operation Option

You can choose from two versions of the PXI-8109 embedded controller to address different environmental and usage conditions. The primary difference between the versions is that the version for extended temperature and 24/7 operation uses a different hard drive that is designed for both reliability in low- and high-temperature extremes and 24/7 operation. The standard version of the controllers has an operating temperature of 5 to 50 °C and a storage temperature of -40 to 65 °C. The extended temperature and 24/7 operation version has an operating temperature of 0 to 55 °C and a storage temperature of -40 to 70 °C.

You can also use the extended temperature and 24/7 operation version for applications that require continuous operation for up to 24 hours/day, seven days/week because the hard drive is rated for 24/7 operation. The hard drive in the standard version of the controllers is designed to be powered on for eight hours/day, five days/week. Additionally, 24/7 operation applications may subject the hard drive to a high-duty cycle (the percentage of the maximum sustained throughput of the hard drive). The hard drive in the extended temperature and 24/7 operation version has a capacity of 80 GB (minimum). See specifications for further details.

USB Peripherals

National Instruments offers a USB-to-dual-PS/2 keyboard/mouse adapter cable to connect a legacy PS/2 keyboard and mouse to a single USB port on your embedded controller. Additionally, NI offers external USB CD-ROM/DVD-ROM and USB floppy drives for use with your embedded controller. Connect these drives to your embedded controller for easy software installation and upgrades. Both are completely powered through the USB ports, so no external power connections are required. Additional USB peripherals, such as USB speakers to add audio or USB memory sticks to add easily removable memory, are widely available from PC peripheral manufacturers.

Hard-Drive-Based Recovery Image

The PXI-8109 embedded controller is shipped with a factory image of the software installation stored on a separate partition of the hard drive. In the case of software corruption, you can invoke a recovery tool during the controller's boot-up process that can use this backup image to restore the controller to its shipping software configuration. You also can use this recovery tool to create custom images that you can store on external mass storage devices such as a USB memory stick, USB hard drives, and USB CD/DVD drives. With this ability, you can create custom backup images that you can use to either recover a PXI-8109 controller or replicate the installation on other PXI-8109 controllers. For more information on this tool, refer to [KnowledgeBase 2ZKC02OK](#).

Software

The PXI-8109 comes with the following minimum set of software already installed:

- Microsoft Windows XP Professional OS (contact National Instruments or visit ni.com/pxiadvisor for localized versions of Windows XP and for other available OSs)
- Hard-drive-based recovery image
- NI-VISA and NI-488.2 drivers
- Drivers for all built-in I/O ports

With an NI system assurance program (base or standard) added to your PXI system order, your embedded controller is shipped already configured with all software and drivers applicable for your system. For example, assume you order a PXI system that includes NI LabVIEW and NI TestStand software, as well as data acquisition modules, a digitizer, an arbitrary waveform generator, and a digital multimeter (DMM). With an NI system assurance program, NI not only assembles and tests your system but also fully configures the embedded controller with the appropriate NI-DAQmx, NI-SCOPE, NI-FGEN, and NI-DMM drivers, as well as LabVIEW and NI TestStand.

Additionally, your embedded controller is configured with a customized hard-drive-based recovery image, so you can restore your controller to the as-shipped configuration at any time. This combination of software configuration and recovery tools provides both a productive and reliable development experience with your PXI system out of the box. To configure a complete PXI system with an NI system assurance program, contact National Instruments or visit ni.com/pxiadvisor.

[Back to Top](#)

Ordering Information

For a complete list of accessories, visit the product page on ni.com.

Products	Part Number	Recommended Accessories	Part Number
Other Accessories			
Micro-GPIB to GPIB cable (2 m)	183285-02	No accessories required.	
External USB CD-ROM/DVD-ROM drive	778492-01	No accessories required.	
ExpressCard strain-relief accessory for embedded controllers	192524-01	No accessories required.	
USB English keyboard and optical mouse	779660-01	No accessories required.	
NI MKD-1117 (rack-mount 1U LCD monitor, keyboard, mouse drawer)	779872-01	No accessories required.	

Parallel port adapter cable (6 in.)	777169-01	No accessories required.
DVI-I (male) to DVI-D (female) and VGA (female) splitter	780868-01	No accessories required.
NI FPT-1015 (flat panel touch screen with VGA interface and USB)	779560-01	No accessories required.
Micro-GPIB to GPIB cable (1 m)	183285-01	No accessories required.
NI FPM-1017 (17 in. flat panel monitor)	779559-01	No accessories required.
USB-to-dual-PS/2 keyboard/mouse adapter cable	778713-02	No accessories required.
NI FPM-1019 (19 in. widescreen flat panel monitor, DVI input)	781002-01	No accessories required.
External USB floppy drive	778492-02	No accessories required.
NI PMA-1115: Portable PXI Monitor and English Keyboard Accessory	780215-01	No accessories required.
NI PXI-8109		
NI PXI-8109 Windows 7 (32-Bit)	781453-04	No accessories required.
NI PXI-8109 Windows 7 (32-Bit) Extended Temp	781454-04	No accessories required.
NI PXI-8109 Windows XP Extended Temp	781454-01	No accessories required.
NI PXI-8109 Windows XP	781453-01	No accessories required.
Hard-Drive Spare/Replacement and Upgrades		
80 GB (or greater) 2.5 in. SATA Ext Temp, 24/7 Blank HDD Spare/Replacement	779175-07	No accessories required.
500 GB 2.5 in SATA Hard Drive Upgrade	781946-01	No accessories required.
250 GB 2.5 in MLC SATA Solid-State Drive Upgrade	781945-01	No accessories required.
120 GB (or greater) 2.5 in. SATA Blank HDD Spare/Replacement	780970-01	No accessories required.
32 GB 2.5 in SATA Solid-State Drive Upgrade	779175-08	No accessories required.

[Back to Top](#)

Support and Services

System Assurance Programs

NI system assurance programs are designed to make it even easier for you to own an NI system. These programs include configuration and deployment services for your NI PXI, CompactRIO, or Compact FieldPoint system. The NI Basic System Assurance Program provides a simple integration test and ensures that your system is delivered completely assembled in one box. When you configure your system with the NI Standard System Assurance Program, you can select from available NI system driver sets and application development environments to create customized, reorderable software configurations. Your system arrives fully assembled and tested in one box with your software preinstalled. When you order your system with the standard program, you also receive system-specific documentation including a bill of materials, an integration test report, a recommended maintenance plan, and frequently asked question documents. Finally, the standard program reduces the total cost of owning an NI system by providing three years of warranty coverage and calibration service. Use the online product advisors at ni.com/advisor to find a system assurance program to meet your needs.

Technical Support

Get answers to your technical questions using the following National Instruments resources.

- **Support** - Visit ni.com/support to access the NI KnowledgeBase, example programs, and tutorials or to contact our applications engineers who are located in NI sales offices around the world and speak the local language.
- **Discussion Forums** - Visit forums.ni.com for a diverse set of discussion boards on topics you care about.
- **Online Community** - Visit community.ni.com to find, contribute, or collaborate on customer-contributed technical content with users like you.

Repair

While you may never need your hardware repaired, NI understands that unexpected events may lead to necessary repairs. NI offers repair services performed by highly trained technicians who quickly return your device with the guarantee that it will perform to factory specifications. For more information, visit ni.com/repair.

Training and Certifications

The NI training and certification program delivers the fastest, most certain route to increased proficiency and productivity using NI software and hardware. Training builds the skills to more efficiently develop robust, maintainable applications, while certification validates your knowledge and ability.

- **Classroom training in cities worldwide** - the most comprehensive hands-on training taught by engineers.
- **On-site training at your facility** - an excellent option to train multiple employees at the same time.
- **Online instructor-led training** - lower-cost, remote training if classroom or on-site courses are not possible.
- **Course kits** - lowest-cost, self-paced training that you can use as reference guides.
- **Training memberships** and training credits - to buy now and schedule training later.

Visit ni.com/training for more information.

Extended Warranty

NI offers options for extending the standard product warranty to meet the life-cycle requirements of your project. In addition, because NI understands that your requirements may change, the extended warranty is flexible in length and easily renewed. For more information, visit ni.com/warranty.

OEM

NI offers design-in consulting and product integration assistance if you need NI products for OEM applications. For information about special pricing and services for OEM customers, visit ni.com/oem.

Alliance

Our Professional Services Team is comprised of NI applications engineers, NI Consulting Services, and a worldwide National Instruments Alliance Partner program of more than 700 independent consultants and integrators. Services range from start-up assistance to turnkey system integration. Visit ni.com/alliance.

[Back to Top](#)

Detailed Specifications

This appendix lists the electrical, mechanical, and environmental specifications of the NI PXI-8109 embedded computer.

Features

NI PXI-8109	
CPU	Intel Core i7-620 M
CPU Frequency	2.66 GHz (base), 3.33 GHz (single-core Turbo mode)
On-die L2 cache	256 KB x2 (256 KB per core)
On-die L3 cache	4 MB shared between cores
Dual-Channel DDR3 RAM, PC3 8500	2 GB Standard, 8 GB Maximum
Hard Drive	120 GB or larger Serial ATA ¹
Ethernet	10/100/1000 BaseTX, 2 ports
GPIO (IEEE 488 Controller)	Yes
Serial Ports (RS-232)	Yes (1)
Parallel Port	Yes (1)
Hi-Speed USB (2.0) Ports	Yes (4)
ExpressCard/34 Slot	Yes
PS/2 Keyboard/Mouse Connector	No
PXI Trigger Bus Input/Output	Yes
Installed Operating System	Windows 7 Professional, Windows XP Professional SP3 for Embedded Systems

Electrical

Voltage (V)	Current (A)	
	Typical	Maximum
+3.3	2 A	3 A
+5 (+5 V _{DC} and +5 V _{IO}) ²	8 A	9.5 A
+12	.050 A	.150 A
-12	0 A	0 A

Physical

Board dimensions	PXI 3U-size module, 8.1 cm × 13 cm × 21.6 cm (3.2 in. × 5.1 in. × 8.5 in.)
Slot requirements	One system slot plus three controller expansion slots
Compatibility	Fully compatible with PXI specification
Weight	1.30 kg (2.87 lb) typical

Environment

Maximum altitude	2,000 m (800 mbar) (at 25 °C ambient temperature)
Pollution Degree	2
Indoor use only.	

Operating Environment

Ambient temperature ^{3 4}

Base

5 to 50 °C ⁵ (Tested in accordance with IEC-60068-2-1 and IEC-60068-2-2)

Extended temperature	0 to 55 °C (Tested in accordance with IEC-60068-2-1 and IEC-60068-2-2)
Relative humidity	10% to 90%, noncondensing (Tested in accordance with IEC-60068-2-56.)



Caution Clean the NI PXI-8109 with a soft nonmetallic brush. Make sure that the device is completely dry and free from contaminants before powering-on the controller again.

Storage Environment

Ambient temperature

Base	–40 to 65 °C (Tested in accordance with IEC-60068-2-1 and IEC-60068-2-2.)
Extended temperature	–40 to 70 °C (Tested in accordance with IEC-60068-2-1 and IEC-60068-2-2.)
Relative humidity	5% to 95%, noncondensing (Tested in accordance with IEC-60068-2-56.)

Shock and Vibration

Operational shock	30 g peak, half-sine, 11 ms pulse (Tested in accordance with IEC-60068-2-27. Test profile developed in accordance with MIL-PRF-28800F.)
Random vibration	
Operating	5 to 500 Hz, 0.3 g _{rms} (with solid-state hard drive)
Nonoperating	5 to 500 Hz, 2.4 g _{rms} (Tested in accordance with IEC-60068-2-64. Nonoperating test profile exceeds the requirements of MIL-PRF-28800F, Class 3.)



Note Specifications are subject to change without notice.

Safety Standards

This product is designed to meet the requirements of the following standards of safety for electrical equipment for measurement, control, and laboratory use:

- IEC 61010-1, EN 61010-1
- UL 61010-1, CSA 61010-1



Note For UL and other safety certifications, refer to the product label or the *Online Product Certification* section.

Electromagnetic Compatibility

This product meets the requirements of the following EMC standards for electrical equipment for measurement, control, and laboratory use:

- EN 61326-1 (IEC 61326-1): Class A emissions; Basic immunity
- EN 55011 (CISPR 11): Group 1, Class A emissions
- AS/NZS CISPR 11: Group 1, Class A emissions
- FCC 47 CFR Part 15B: Class A emissions
- ICES-001: Class A emissions



Note For EMC declarations and certifications, refer to the *Online Product Certification* section.



Note For EMC compliance, operate this device with shielded cables and accessories.

CE Compliance

This product meets the essential requirements of applicable European Directives, as amended for CE marking, as follows:

- 2006/95/EC; Low-Voltage Directive (safety)
- 2004/108/EC; Electromagnetic Compatibility Directive (EMC)

Online Product Certification

To obtain product certifications and the DoC for this product, visit ni.com/certification, search by model number or product line, and click the appropriate link in the Certification column.

Environmental Management

NI is committed to designing and manufacturing products in an environmentally responsible manner. NI recognizes that eliminating certain hazardous substances from our products is beneficial not only to the environment but also to NI customers.

For additional environmental information, refer to the *NI and the Environment* Web page at ni.com/environment. This page contains the environmental regulations and directives with which NI complies, as well as other environmental information not included in this document.

Waste Electrical and Electronic Equipment (WEEE)



EU Customers At the end of the product life cycle, all products *must* be sent to a WEEE recycling center. For more information about WEEE recycling centers, National Instruments WEEE initiatives, and compliance with WEEE Directive 2002/96/EC on Waste Electrical and Electronic Equipment, visit ni.com/environment/weee.htm.

Battery Replacement and Disposal



Battery Directive This device contains a long-life coin cell battery. If you need to replace it, use the Return Material Authorization (RMA) process or contact an authorized National Instruments service representative. For more information about compliance with the EU Battery Directive 2006/66/EC about Batteries and Accumulators and Waste Batteries and Accumulators, visit ni.com/environment/batterydirective.

电子信息产品污染控制管理办法（中国 RoHS）



中国客户 National Instruments 符合中国电子信息产品中限制使用某些有害物质指令 (RoHS)。
关于 National Instruments 中国 RoHS 合规性信息，请登录 ni.com/environment/rohs_china。
(For information about China RoHS compliance, go to ni.com/environment/rohs_china.)

¹ Extended-temperature 24/7 option provides 80 GB minimum hard drive.

² Does not include any attached USB devices or ExpressCard.

³ For chassis that are not available in the online catalog at ni.com, contact National Instruments for supported operating temperatures.

⁴ Processor should not throttle CPU frequency under reasonable, worst case processor work loads in high operating temperatures.

⁵ 5 to 40 °C for the PXI-1000B DC.

[Back to Top](#)

©2010 National Instruments. All rights reserved. CompactRIO, FieldPoint, LabVIEW, National Instruments, National Instruments Alliance Partner, NI, ni.com, NI-DAQ, and NI TestStand are trademarks of National Instruments. Other product and company names listed are trademarks or trade names of their respective companies. A National Instruments Alliance Partner is a business entity independent from National Instruments and has no agency, partnership, or joint-venture relationship with National Instruments.

[My Profile](#) | [RSS](#) | [Privacy](#) | [Legal](#) | [Contact NI](#) © 2014 National Instruments Corporation. All rights reserved.