

## COMPREHENSIVE SERVICES

We offer competitive repair and calibration services, as well as easily accessible documentation and free downloadable resources.

## SELL YOUR SURPLUS

We buy new, used, decommissioned, and surplus parts from every NI series. We work out the best solution to suit your individual needs.

 Sell For Cash    Get Credit    Receive a Trade-In Deal

## OBSOLETE NI HARDWARE IN STOCK & READY TO SHIP

We stock **New**, **New Surplus**, **Refurbished**, and **Reconditioned** NI Hardware.



*Bridging the gap between the manufacturer and your legacy test system.*

 1-800-915-6216

 [www.apexwaves.com](http://www.apexwaves.com)

 [sales@apexwaves.com](mailto:sales@apexwaves.com)

*All trademarks, brands, and brand names are the property of their respective owners.*

**Request a Quote**

 **CLICK HERE**

**PXI-1036**

# PXI

## NI PXI-1036/PXI-1036DC User Manual

## **Worldwide Technical Support and Product Information**

ni.com

### **National Instruments Corporate Headquarters**

11500 North Mopac Expressway Austin, Texas 78759-3504 USA Tel: 512 683 0100

### **Worldwide Offices**

Australia 1800 300 800, Austria 43 662 457990-0, Belgium 32 (0) 2 757 0020, Brazil 55 11 3262 3599,  
Canada 800 433 3488, China 86 21 5050 9800, Czech Republic 420 224 235 774, Denmark 45 45 76 26 00,  
Finland 358 (0) 9 725 72511, France 01 57 66 24 24, Germany 49 89 7413130, India 91 80 41190000,  
Israel 972 3 6393737, Italy 39 02 41309277, Japan 0120-527196, Korea 82 02 3451 3400,  
Lebanon 961 (0) 1 33 28 28, Malaysia 1800 887710, Mexico 01 800 010 0793, Netherlands 31 (0) 348 433 466,  
New Zealand 0800 553 322, Norway 47 (0) 66 90 76 60, Poland 48 22 328 90 10, Portugal 351 210 311 210,  
Russia 7 495 783 6851, Singapore 1800 226 5886, Slovenia 386 3 425 42 00, South Africa 27 0 11 805 8197,  
Spain 34 91 640 0085, Sweden 46 (0) 8 587 895 00, Switzerland 41 56 2005151, Taiwan 886 02 2377 2222,  
Thailand 662 278 6777, Turkey 90 212 279 3031, United Kingdom 44 (0) 1635 523545

For further support information, refer to the *Technical Support and Professional Services* appendix. To comment on National Instruments documentation, refer to the National Instruments Web site at [ni.com/info](http://ni.com/info) and enter the Info Code feedback.

# Important Information

---

## Warranty

The NI PXI-1036/PXI-1036DC chassis is warranted against defects in materials and workmanship for a period of one year from the date of shipment, as evidenced by receipts or other documentation. National Instruments will, at its option, repair or replace equipment that proves to be defective during the warranty period. This warranty includes parts and labor.

The media on which you receive National Instruments software are warranted not to fail to execute programming instructions, due to defects in materials and workmanship, for a period of 90 days from date of shipment, as evidenced by receipts or other documentation. National Instruments will, at its option, repair or replace software media that do not execute programming instructions if National Instruments receives notice of such defects during the warranty period. National Instruments does not warrant that the operation of the software shall be uninterrupted or error free.

A Return Material Authorization (RMA) number must be obtained from the factory and clearly marked on the outside of the package before any equipment will be accepted for warranty work. National Instruments will pay the shipping costs of returning to the owner parts which are covered by warranty.

National Instruments believes that the information in this document is accurate. The document has been carefully reviewed for technical accuracy. In the event that technical or typographical errors exist, National Instruments reserves the right to make changes to subsequent editions of this document without prior notice to holders of this edition. The reader should consult National Instruments if errors are suspected. In no event shall National Instruments be liable for any damages arising out of or related to this document or the information contained in it.

EXCEPT AS SPECIFIED HEREIN, NATIONAL INSTRUMENTS MAKES NO WARRANTIES, EXPRESS OR IMPLIED, AND SPECIFICALLY DISCLAIMS ANY WARRANTY OF MERCHANTABILITY OR FITNESS FOR A PARTICULAR PURPOSE. CUSTOMER'S RIGHT TO RECOVER DAMAGES CAUSED BY FAULT OR NEGLIGENCE ON THE PART OF NATIONAL INSTRUMENTS SHALL BE LIMITED TO THE AMOUNT THEREOF PAID BY THE CUSTOMER. NATIONAL INSTRUMENTS WILL NOT BE LIABLE FOR DAMAGES RESULTING FROM LOSS OF DATA, PROFITS, USE OF PRODUCTS, OR INCIDENTAL OR CONSEQUENTIAL DAMAGES, EVEN IF ADVISED OF THE POSSIBILITY THEREOF. This limitation of the liability of National Instruments will apply regardless of the form of action, whether in contract or tort, including negligence. Any action against National Instruments must be brought within one year after the cause of action accrues. National Instruments shall not be liable for any delay in performance due to causes beyond its reasonable control. The warranty provided herein does not cover damages, defects, malfunctions, or service failures caused by owner's failure to follow the National Instruments installation, operation, or maintenance instructions; owner's modification of the product; owner's abuse, misuse, or negligent acts; and power failure or surges, fire, flood, accident, actions of third parties, or other events outside reasonable control.

## Copyright

Under the copyright laws, this publication may not be reproduced or transmitted in any form, electronic or mechanical, including photocopying, recording, storing in an information retrieval system, or translating, in whole or in part, without the prior written consent of National Instruments Corporation.

National Instruments respects the intellectual property of others, and we ask our users to do the same. NI software is protected by copyright and other intellectual property laws. Where NI software may be used to reproduce software or other materials belonging to others, you may use NI software only to reproduce materials that you may reproduce in accordance with the terms of any applicable license or other legal restriction.

## Trademarks

LabVIEW, National Instruments, NI, ni.com, the National Instruments corporate logo, and the Eagle logo are trademarks of National Instruments Corporation. Refer to the *Trademark Information* at [ni.com/trademarks](http://ni.com/trademarks) for other National Instruments trademarks.

Other product and company names mentioned herein are trademarks or trade names of their respective companies.

Members of the National Instruments Alliance Partner Program are business entities independent from National Instruments and have no agency, partnership, or joint-venture relationship with National Instruments.

## Patents

For patents covering National Instruments products/technology, refer to the appropriate location: **Help»Patents** in your software, the `patents.txt` file on your media, or the *National Instruments Patent Notice* at [ni.com/patents](http://ni.com/patents).

## WARNING REGARDING USE OF NATIONAL INSTRUMENTS PRODUCTS

(1) NATIONAL INSTRUMENTS PRODUCTS ARE NOT DESIGNED WITH COMPONENTS AND TESTING FOR A LEVEL OF RELIABILITY SUITABLE FOR USE IN OR IN CONNECTION WITH SURGICAL IMPLANTS OR AS CRITICAL COMPONENTS IN ANY LIFE SUPPORT SYSTEMS WHOSE FAILURE TO PERFORM CAN REASONABLY BE EXPECTED TO CAUSE SIGNIFICANT INJURY TO A HUMAN.

(2) IN ANY APPLICATION, INCLUDING THE ABOVE, RELIABILITY OF OPERATION OF THE SOFTWARE PRODUCTS CAN BE IMPAIRED BY ADVERSE FACTORS, INCLUDING BUT NOT LIMITED TO FLUCTUATIONS IN ELECTRICAL POWER SUPPLY, COMPUTER HARDWARE MALFUNCTIONS, COMPUTER OPERATING SYSTEM SOFTWARE FITNESS, FITNESS OF COMPILERS AND DEVELOPMENT SOFTWARE USED TO DEVELOP AN APPLICATION, INSTALLATION ERRORS, SOFTWARE AND HARDWARE COMPATIBILITY PROBLEMS, MALFUNCTIONS OR FAILURES OF ELECTRONIC MONITORING OR CONTROL DEVICES, TRANSIENT FAILURES OF ELECTRONIC SYSTEMS (HARDWARE AND/OR SOFTWARE), UNANTICIPATED USES OR MISUSES, OR ERRORS ON THE PART OF THE USER OR APPLICATIONS DESIGNER (ADVERSE FACTORS SUCH AS THESE ARE HEREAFTER COLLECTIVELY TERMED "SYSTEM FAILURES"). ANY APPLICATION WHERE A SYSTEM FAILURE WOULD CREATE A RISK OF HARM TO PROPERTY OR PERSONS (INCLUDING THE RISK OF BODILY INJURY AND DEATH) SHOULD NOT BE RELIANT SOLELY UPON ONE FORM OF ELECTRONIC SYSTEM DUE TO THE RISK OF SYSTEM FAILURE. TO AVOID DAMAGE, INJURY, OR DEATH, THE USER OR APPLICATION DESIGNER MUST TAKE REASONABLY PRUDENT STEPS TO PROTECT AGAINST SYSTEM FAILURES, INCLUDING BUT NOT LIMITED TO BACK-UP OR SHUT DOWN MECHANISMS. BECAUSE EACH END-USER SYSTEM IS CUSTOMIZED AND DIFFERS FROM NATIONAL INSTRUMENTS' TESTING PLATFORMS AND BECAUSE A USER OR APPLICATION DESIGNER MAY USE NATIONAL INSTRUMENTS PRODUCTS IN COMBINATION WITH OTHER PRODUCTS IN A MANNER NOT EVALUATED OR CONTEMPLATED BY NATIONAL INSTRUMENTS, THE USER OR APPLICATION DESIGNER IS ULTIMATELY RESPONSIBLE FOR VERIFYING AND VALIDATING THE SUITABILITY OF NATIONAL INSTRUMENTS PRODUCTS WHENEVER NATIONAL INSTRUMENTS PRODUCTS ARE INCORPORATED IN A SYSTEM OR APPLICATION, INCLUDING, WITHOUT LIMITATION, THE APPROPRIATE DESIGN, PROCESS AND SAFETY LEVEL OF SUCH SYSTEM OR APPLICATION.

# Contents

---

## About This Manual

Conventions .....	vii
Related Documentation.....	viii

## Chapter 1

### Getting Started

Unpacking .....	1-1
What You Need to Get Started .....	1-1
Key Features .....	1-2
Chassis Description.....	1-3
Optional Equipment .....	1-5
EMC Filler Panels .....	1-5
Rack Mount Kits.....	1-5
Handle/Feet Kit .....	1-5
DC Power Cable (PXI-1036DC Only).....	1-6
PXI-1036/PXI-1036DC Backplane Overview.....	1-6
Interoperability with CompactPCI .....	1-6
System Controller Slot .....	1-7
Star Trigger Slot .....	1-7
Peripheral Slots.....	1-7
Local Bus.....	1-7
Trigger Bus .....	1-8
System Reference Clock.....	1-8

## Chapter 2

### Installation and Configuration

Safety Information .....	2-1
Chassis Cooling Considerations .....	2-2
Providing Adequate Clearance.....	2-2
Setting Fan Speed .....	2-3
Installing Filler Panels .....	2-3
Rack Mounting .....	2-4
Connecting Safety Ground.....	2-4
Connecting to Power Source.....	2-4
Connecting to an AC Power Source.....	2-5
Connecting to a DC Power Source (PXI-1036DC Only).....	2-5
DC Connector .....	2-5
Installing a PXI Controller.....	2-6

Installing PXI Modules.....	2-8
PXI System Configuration with MAX.....	2-10
Basic PXI System Configuration .....	2-10
Trigger Configuration in MAX.....	2-11
Using System Configuration and Initialization Files .....	2-12

## **Chapter 3**

### **Maintenance**

DC Fuse Replacement (PXI-1036DC Only) .....	3-1
Service Interval.....	3-1
Preparation.....	3-1
Cleaning.....	3-2
Interior Cleaning .....	3-2
Exterior Cleaning .....	3-2

## **Appendix A**

### **Specifications**

## **Appendix B**

### **Pinouts**

## **Appendix C**

### **Technical Support and Professional Services**

## **Glossary**

## **Index**

# About This Manual

---

The *NI PXI-1036/PXI-1036DC User Manual* contains information about installing, configuring, using, and maintaining the NI PXI-1036 and PXI-1036DC chassis.

## Conventions

---

The following conventions are used in this manual:

» The » symbol leads you through nested menu items and dialog box options to a final action. The sequence **Options»Settings»General** directs you to pull down the **Options** menu, select the **Settings** item, and select **General** from the last dialog box.



This icon denotes a note, which alerts you to important information.



This icon denotes a caution, which advises you of precautions to take to avoid injury, data loss, or a system crash. When this symbol is marked on the product, refer to the *Read Me First: Safety and Electromagnetic Compatibility* document, shipped with the product, for precautions to take.

**bold** Bold text denotes items that you must select or click in the software, such as menu items and dialog box options. Bold text also denotes parameter names.

*italic* Italic text denotes variables, emphasis, a cross-reference, a hardware label, or an introduction to a key concept. Italic text also denotes text that is a placeholder for a word or value that you must supply.

monospace Text in this font denotes text or characters that you should enter from the keyboard, sections of code, programming examples, and syntax examples. This font is also used for the proper names of disk drives, paths, directories, programs, subprograms, subroutines, device names, functions, operations, variables, filenames, and extensions.

## Related Documentation

---

The following documents contain information that you might find helpful as you read this manual:

- *NI PXI-1031DC/1036DC DC Cable Kit Installation Guide*
- *CompactPCI Specification PICMG 2.0 R 3.0*
- *PXI Hardware Specification*
- *PXI Software Specification*
- *IEEE 1101.1-1991, IEEE Standard for Mechanical Core Specifications for Microcomputers Using IEC 603-2 Connectors*
- *IEEE 1101.10, IEEE Standard for Additional Mechanical Specifications for Microcomputers Using IEEE 1101.1 Equipment Practice*



---

# Getting Started

This chapter describes the key features of the NI PXI-1036 and PXI-1036DC chassis, and lists the kit contents and optional equipment you can order from National Instruments.

## Unpacking

---

Carefully inspect the shipping container and the chassis for damage. Check for visible damage to the metal work. Check to make sure all handles, hardware, and switches are undamaged. Inspect the inner chassis for any possible damage, debris, or detached components. If damage appears to have been caused during shipment, file a claim with the carrier. Retain the packing material for possible inspection and/or reshipment.

## What You Need to Get Started

---

- NI PXI-1036 or NI PXI-1036DC chassis
- Filler panels
- Power cable, either:
  - AC power cable—refer to Table 1-1 for AC power cables
  - DC power cable (PXI-1036DC only)
- NI PXI-1036/PXI-1036DC User Manual*
- Read Me First: Safety and Electromagnetic Compatibility*
- Driver CD-ROM containing NI PXI chassis software
- Chassis number labels

**Table 1-1.** AC Power Cables

<b>Power Cable</b>	<b>Reference Standards</b>
Standard 120 V (USA)	NEMA 5-15
Switzerland 220 V	SEV
Australia 240 V	AS C112
Universal Euro 230 V	CEE (7), II, IV, VII IEC83
North America 240 V	NEMA 6-15
United Kingdom 230 V	BS 1363/IEC83
Japan 100 V	JIS C8303

If you are missing any of the items listed in Table 1-1, or if you have the incorrect AC power cable, contact National Instruments.

You have the option of powering the PXI-1036DC chassis with a DC power cable through the DC input connector on the rear panel of the chassis. Refer to Figure 1-3 for the location of the DC connector.

## Key Features

---

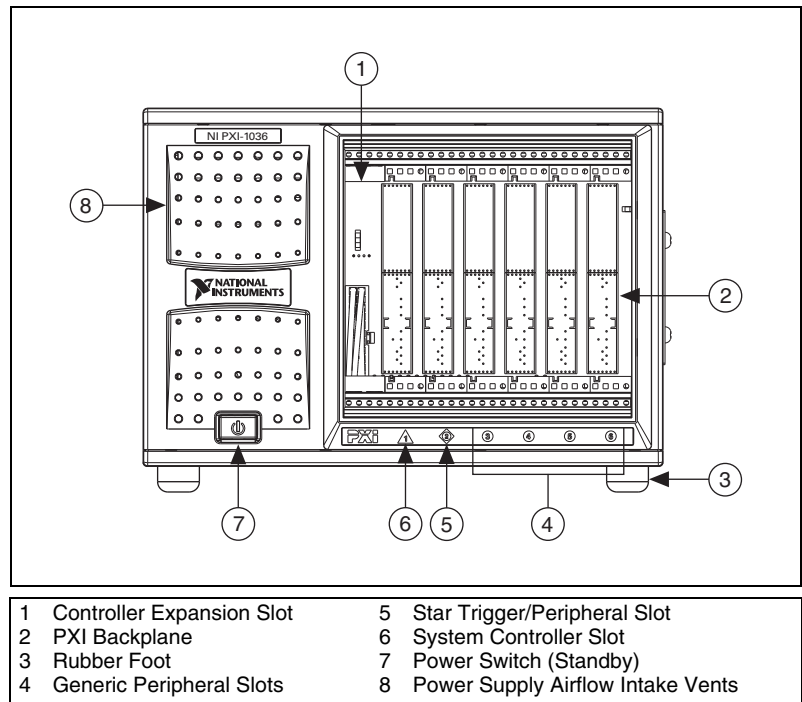
The PXI-1036/PXI-1036DC combines a 6-slot PXI backplane with a structural design that has been optimized for maximum usability in a wide range of applications.

The key features of the chassis include the following:

- Accepts 3U PXI and CompactPCI (PICMG 2.0 R 3.0) modules
- 6-slot chassis with universal AC input, and automatic voltage/frequency ranging
- DC power input (PXI-1036DC only)
- On/Off (Standby) power switch on the front panel for easy access
- AUTO/HIGH temperature-controlled fan speed based on air-intake temperature to minimize audible noise
- (Optional) Carrying handle for portability
- Rack mountable

# Chassis Description

Figure 1-1, Figure 1-2, and Figure 1-3 show the key features of the PXI-1036/PXI-1036DC chassis front and rear panels. Figure 1-1 shows the front view of the PXI-1036 (the PXI-1036DC front panel is identical except for the chassis name stenciled on the face plate). Figure 1-2 shows the rear view of the PXI-1036. Figure 1-3 shows the rear panel of the PXI-1036DC. Figure 1-4 shows the bottom of the chassis (both types of chassis will be identical on the bottom).



**Figure 1-1.** Front View of the PXI-1036 Chassis

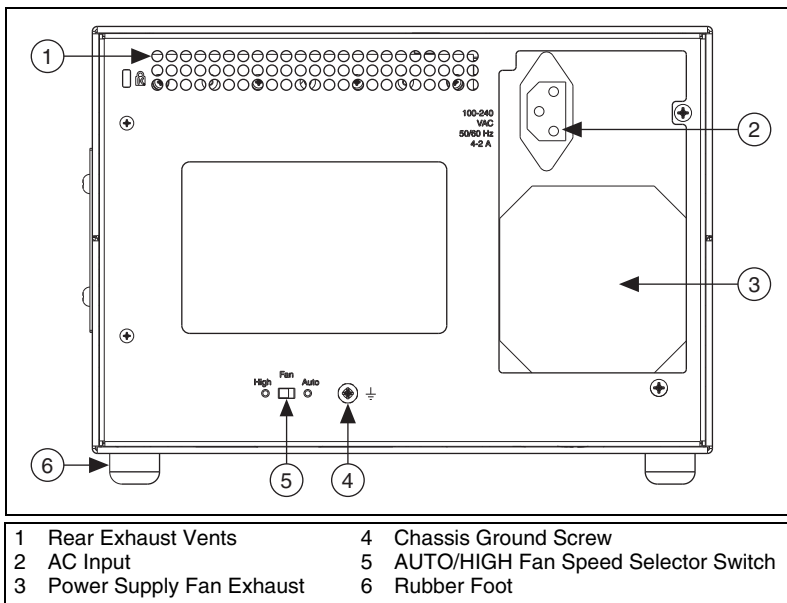


Figure 1-2. Rear View of the PXI-1036 Chassis

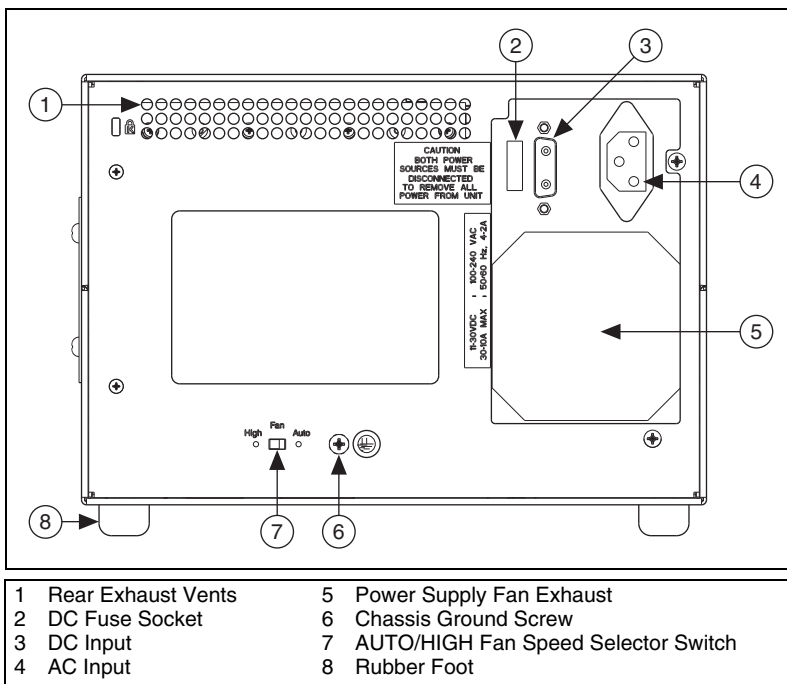
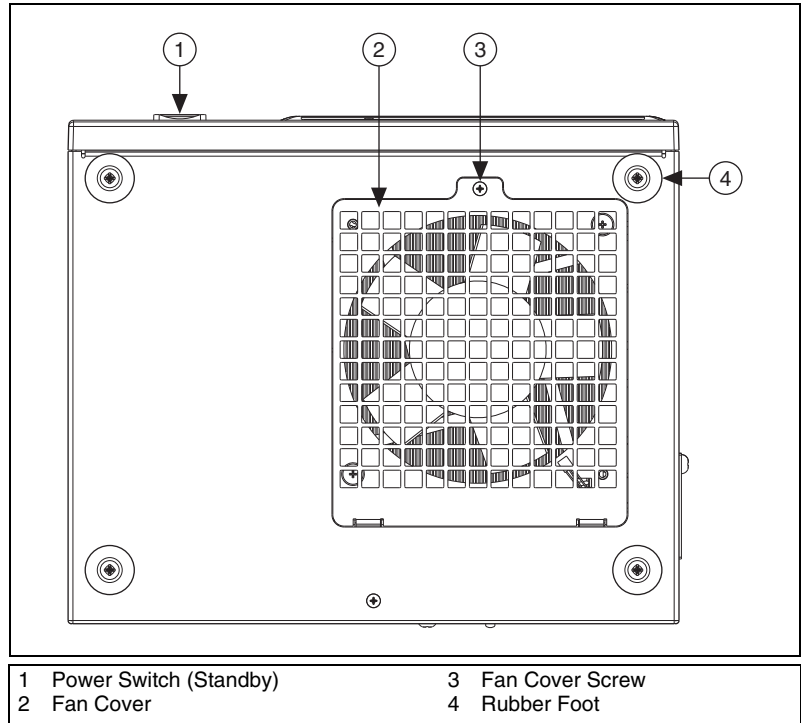


Figure 1-3. Rear View of the PXI-1036DC Chassis



**Figure 1-4.** Bottom View of PXI-1036/PXI-1036DC Chassis

## Optional Equipment

Contact National Instruments to order the following options for the PXI-1036/PXI-1036DC chassis.

### EMC Filler Panels

Optional EMC filler panel kits are available from National Instruments.

### Rack Mount Kits

A rack mount kit option is available for mounting the PXI-1036 or PXI-1036DC chassis into a 19 in. instrument cabinet.

### Handle/Feet Kit

An optional side handle and rubber feet kit is available from National Instruments to provide a handle for portability.

## DC Power Cable (PXI-1036DC Only)

An optional DC power cable is available from National Instruments to provide power through the DC input connector on the rear panel of the chassis.

The DC power cable uses an F30A 500 VDC/600 VAC, 1.5 in. × .41 in. (10 mm × 38 mm) Midget fast-acting fuse on the positive (+) wire of the cable. For more information on fuses used, including recommendations for custom cabling, refer to the [DC Fuse Replacement \(PXI-1036DC Only\)](#) section of Chapter 3, [Maintenance](#).

## PXI-1036/PXI-1036DC Backplane Overview

---

### Interoperability with CompactPCI

The PXI-1036/PXI-1036DC backplane is interoperable with 5 V and universal PXI-compatible products and standard CompactPCI products. This is an important feature, because some PXI systems may require components that do not implement PXI-specific features. For example, you may want to use a standard CompactPCI network interface card in a PXI chassis.

The signals on the backplane P1 connectors meet the requirements of the CompactPCI specification for both peripheral and system modules. Refer to Appendix B, [Pinouts](#), for pinout information.

The PXI-specific signals are on the backplane P2 connectors and are found only on those signal lines reserved or not used in the CompactPCI 64-bit specification. Therefore, all modules that meet the requirements of the CompactPCI 64-bit specification will function in the PXI-1036/PXI-1036DC. Refer to Appendix B, [Pinouts](#), for pinout information.



**Note** The PXI-1036/PXI-1036DC backplane is 32-bit PCI. 64-bit CompactPCI cards will operate in 32-bit mode in this chassis.

The chassis backplane has +5 V V(I/O). Refer to the *CompactPCI Specification PICMG 2.0 R 3.0* for details regarding V(I/O).

## System Controller Slot

The system controller slot is slot 1 of the chassis as defined by the PXI specification. It has one controller expansion slot for system controller modules that are wider than one slot. As defined in the PXI specification, these slots allow the controller to expand to the left to prevent the controller from using peripheral slots.

## Star Trigger Slot

The star trigger (ST) slot is slot 2. This slot has dedicated equal-length trigger lines between slot 2 and peripheral slots 3 through 6 (refer to Figure 1-5). Slot 2 is intended for modules with ST functionality that can provide individual triggers to all other peripheral modules. However, if you do not require advanced trigger functionality, you can install any standard peripheral module in this slot.

The star trigger slot can also be used to provide a PXI\_CLK10 signal to the backplane. For more information regarding PXI\_CLK10, refer to the [System Reference Clock](#) section.

## Peripheral Slots

There are five peripheral slots, including the star trigger slot.

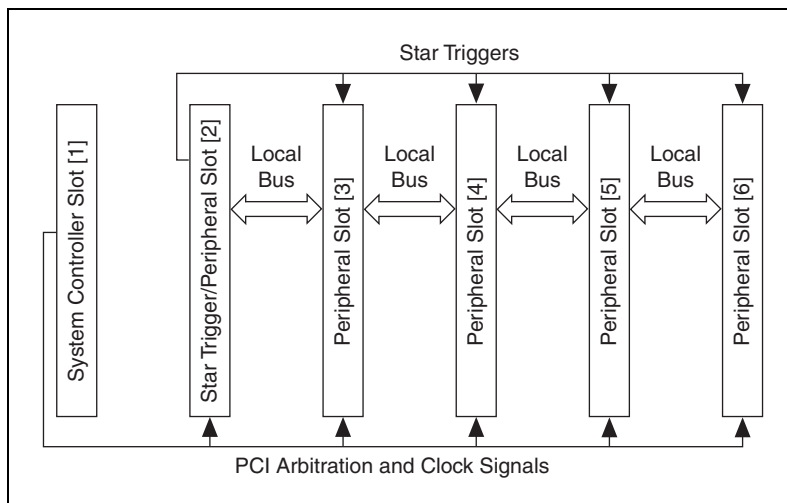
## Local Bus

The PXI backplane local bus is a daisy-chained bus that connects each peripheral slot with adjacent peripheral slots to the left and right (refer to Figure 1-5). For example, the right local bus of slot 2 connects to the left local bus of slot 3, and so on.

The left local bus signal lines on slot 2 are used for star trigger and do not connect to slot 1. The right local bus signal lines on slot 6 are not routed anywhere.

Each local bus is 13 lines wide and can pass analog signals up to 42 V between cards or provide a high-speed TTL side-band digital communication path that does not reduce the PXI bus bandwidth.

Initialization software uses the configuration information specific to adjacent peripheral modules to evaluate local bus compatibility.



**Figure 1-5.** PXI Star Trigger and Local Bus Routing

## Trigger Bus

All slots share eight PXI trigger lines. You can use these trigger lines in a variety of ways. For example, you can use triggers to synchronize the operation of several different PXI peripheral modules. In other applications, one module located in slot 2 can control carefully timed sequences of operations performed on other modules in the system. Modules can pass triggers to one another, allowing precisely timed responses to asynchronous external events the system is monitoring or controlling.

## System Reference Clock

The PXI-1036/PXI-1036DC supplies the PXI 10 MHz system clock signal (PXI\_CLK10) independently to each peripheral slot. An independent buffer (having a source impedance matched to the backplane and a skew of less than 250 ps between slots) drives the clock signal to each peripheral slot. You can use this common reference clock signal to synchronize multiple modules in a measurement or control system. You can drive PXI\_CLK10 from an external source through the PXI\_CLK10\_IN pin on the P2 connector of the star trigger slot. Refer to Table B-4, [P2 \(J2\) Connector Pinout for the Star Trigger Slot](#). You must manually switch S1 on the chassis backplane to enable or disable routing an external clock to peripheral slots.



---

# Installation and Configuration

This chapter describes how to install, configure, and use the PXI-1036 and PXI-1036DC chassis.

Before connecting the chassis to a power source, read this chapter and the *Read Me First: Safety and Electromagnetic Compatibility* document included with your chassis.

---

## Safety Information



**Caution** Before undertaking any troubleshooting, maintenance, or exploratory procedure, carefully read the following caution notices.

This equipment contains voltage hazardous to human life and safety, and is capable of inflicting personal injury.

- **Chassis Grounding**—The chassis requires a connection from the premise wire safety ground to the chassis ground. The earth safety ground must be connected during use of this equipment to minimize shock hazards. Refer to the [Connecting Safety Ground](#) section for instructions on connecting safety ground.
- **Live Circuits**—Operating personnel and service personnel *must not* remove protective covers when operating or servicing the chassis. Adjustments and service to internal components must be undertaken by qualified service technicians. During service of this product, the mains connector to the premise wiring must be disconnected. Dangerous voltages may be present under certain conditions; use extreme caution.
- **Explosive Atmosphere**—Do *not* operate the chassis in conditions where flammable gases are present. Under such conditions, this equipment is unsafe and may ignite the gases or gas fumes.
- **Part Replacement**—Only service this equipment with parts that are exact replacements, both electrically and mechanically. Contact National Instruments for replacement part information. Installation of parts with those that are not direct replacements may cause harm to

personnel operating the chassis. Furthermore, damage or fire may occur if replacement parts are unsuitable.

- **Modification**—Do *not* modify any part of the chassis from its original condition. Unsuitable modifications may result in safety hazards.

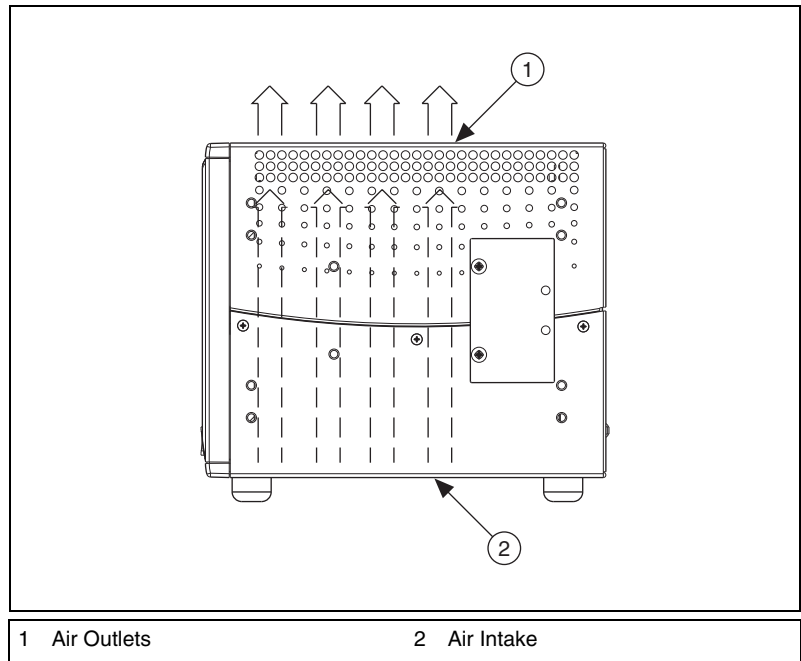
## Chassis Cooling Considerations

---

The chassis is designed to operate on a bench or in an instrument rack. Determine how you want to use the chassis and follow the appropriate installation instructions.

### Providing Adequate Clearance

Apertures in the top, bottom, front, rear, and along the right and left sides of the chassis facilitate power supply and module cooling. Air enters through the fan inlet in the bottom of the chassis for module cooling. It then exits through the upper sections at the right side, back, and through the top, as shown in Figure 2-1. Air cooling the power supply enters the front and left side of the chassis, which is shown in Figure 1-1, *Front View of the PXI-1036 Chassis*, then exits through the rear of the chassis, which is shown in Figure 1-2, *Rear View of the PXI-1036 Chassis*, and Figure 1-3, *Rear View of the PXI-1036DC Chassis*. Place the chassis on a bench top or in an instrument rack so that the fans (air inlets) and the air outlet apertures along the right and left sides, the top, and the back of the chassis have adequate ventilation. Provide at least 44.5 mm (1.75 in.) clearance above, behind, and on the sides of the unit for adequate venting. High-power applications may require additional clearance.



**Figure 2-1.** PXI-1036/PXI-1036DC Module Cooling Airflow Side View

Install the chassis so that you can easily access the bottom panel.

## Setting Fan Speed

The AUTO/HIGH fan-speed selector switch is on the rear panel of the PXI-1036 and PXI-1036DC. Refer to Figure 1-2, *Rear View of the PXI-1036 Chassis*, or Figure 1-3, *Rear View of the PXI-1036DC Chassis*, to locate the fan-speed selector switch. Select HIGH for maximum cooling performance (recommended) or AUTO for quieter operation. The fan speed is determined by chassis intake air temperature when set to AUTO.

## Installing Filler Panels

To improve module cooling performance, install filler panels (provided with the chassis) in unused or empty slots. Secure with the captive mounting screws provided.

## Rack Mounting

---

Rack mount applications require the optional rack mount kits available from National Instruments. Refer to Figure A-3, [PXI-1036/PXI-1036DC Rack Mount Kit Components](#), and the instructions supplied with the rack mount kits to install your chassis in an instrument rack.



**Note** You may want to remove the feet from the chassis when rack mounting. To do so, remove the screws holding the feet in place.

## Connecting Safety Ground

---



**Caution** The PXI-1036/PXI-1036DC chassis is designed with a three-position inlet that connects the cord set ground line to the chassis ground. To minimize shock hazard, make sure the electrical power outlet you use to power the chassis has an appropriate earth safety ground.

For DC powered applications, or if your power outlet does not have an appropriate ground connection, you must connect the premise safety ground to the chassis grounding screw located on the rear panel. Refer to Figure 1-2, [Rear View of the PXI-1036 Chassis](#), or Figure 1-3, [Rear View of the PXI-1036DC Chassis](#), to locate the chassis grounding screw. Complete the following steps to connect the safety ground.

1. Connect a 10 AWG (2.6 mm) wire to the chassis grounding screw using a grounding lug. The wire must have green insulation with a yellow stripe or must be noninsulated (bare).
2. Attach the opposite end of the wire to permanent earth ground using toothed washers or a toothed lug.

## Connecting to Power Source

---



**Cautions** Do *not* install modules prior to performing the following power-on test.

To completely remove power, you *must* disconnect the AC power cable (and DC power, if applicable).

If both AC and DC power cables are connected, the chassis will draw power from both sources.

## Connecting to an AC Power Source

Attach input power through the rear AC inlet using the appropriate AC power cable supplied. Refer to Figure 1-2, *Rear View of the PXI-1036 Chassis*, or to Figure 1-3, *Rear View of the PXI-1036DC Chassis*, to locate the AC inlet.

The power switch allows you to power on the chassis or place it in standby mode. Press the power switch to the On position (if not already on). Observe that all fans become operational.

## Connecting to a DC Power Source (PXI-1036DC Only)

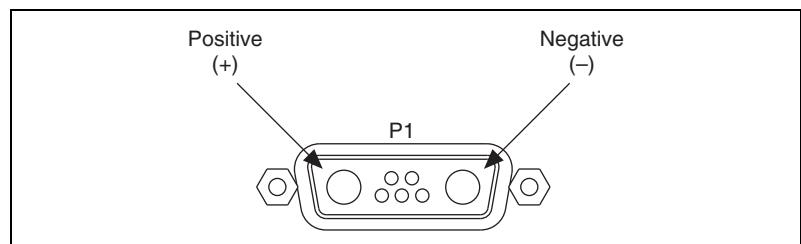
**Table 2-1.** DC Power Requirements

Electrical Element	Requirement
Voltage	18–30 VDC
DC Input Current	30–10 A

For full chassis power, the DC source must be capable of providing a minimum of 300 watts of continuous power per feed pair to the P1 connector on the PXI-1036DC power supply.

### DC Connector

Figure 2-2 shows the DC connector (P1) that appears on the rear panel of the PXI-1036DC power supply.



**Figure 2-2.** The P1 DC Input Connector

To build a custom DC cable, be sure to note the positive (+) and negative (–) terminals shown in Figure 2-2. Use the following components or their equivalents to mate to the P1 port:

- Positronic connector, part number CBD7W2F0000
- Positronic hood, part number D15000GE0

- Two Positronic contacts, part number FS4008D (choice of solder cup or crimp terminals)
- Use of UL listed AWG #10 wire is recommended (maximum length: 216 in.)

Install an F30A 500 VDC/600 VAC, 1.5 in. × .41 in. (10 mm × 38 mm) Midget fast-acting fuse on the positive (+) wire of the custom cable as close to the power source as practical.

- A Ferraz-Shawmut FEB-81-81 fuse holder, with Ferraz-Shawmut FSB1 insulating boots, and an ATM30 fuse is recommended.

Refer to the *NI PXI-1036DC DC Cable Kit Installation Guide* for information on fuse installation.



**Note** You can purchase an optional DC cable from National Instruments that incorporates an in-line fuse and the mating connector for the P1 port.

## Installing a PXI Controller

---

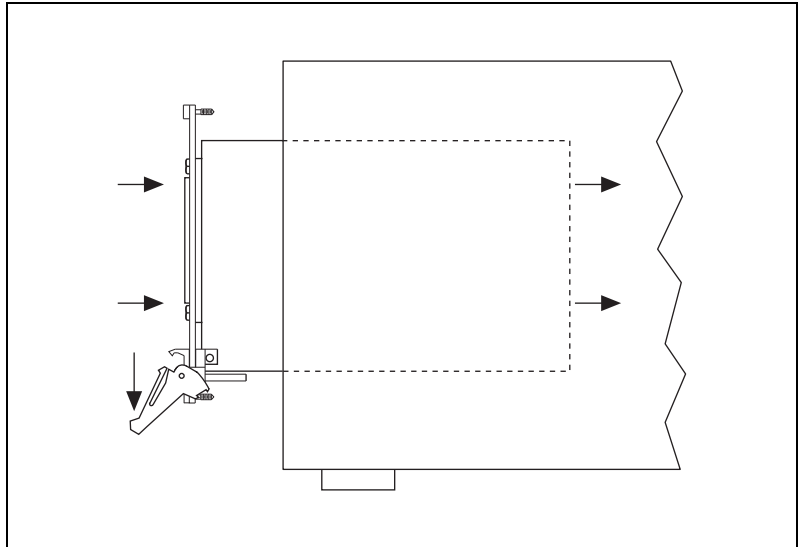
This section contains general instructions for installing a PXI controller in the chassis. Refer to your PXI controller user manual for specific instructions and cautions. Complete the following steps to install a controller.

1. Connect the AC or DC power source to the PXI chassis before installing the controller. The AC power cord grounds the chassis and protects it from electrical damage while you install the controller. For DC powered applications, make sure the chassis is properly grounded through the chassis ground screw. Make sure the chassis power switch is in the Off (Standby) position.



**Caution** To protect both yourself and the chassis from electrical hazards, leave the chassis off until you finish installing the controller.

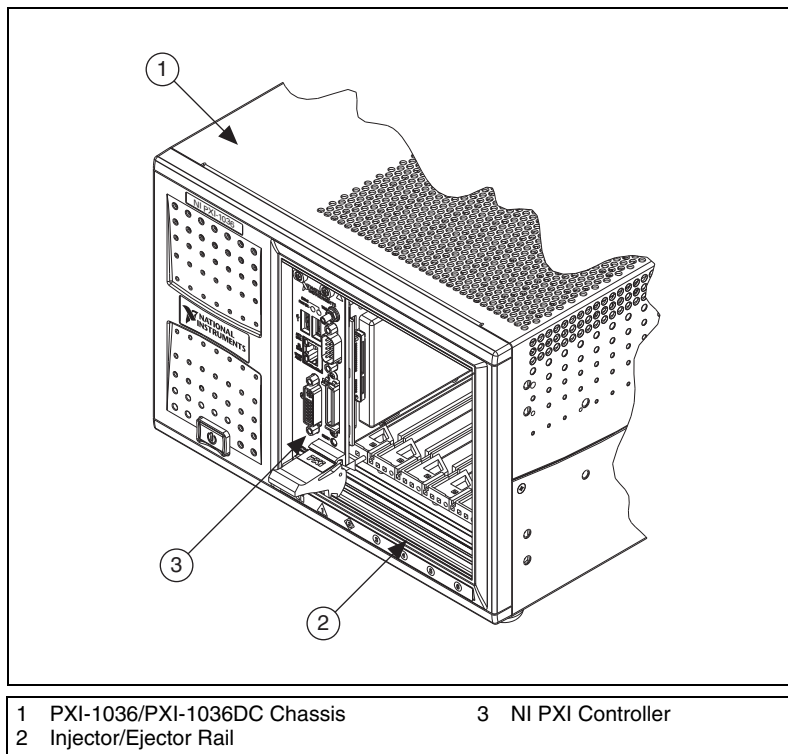
2. Install the controller into the system controller slot (slot 1, indicated by the red card guides) by first placing the controller edges into the front controller guides (top and bottom). Slide the controller to the rear of the chassis, making sure that the injector/ejector handle is pushed down as shown in Figure 2-3.



**Figure 2-3.** Injector/Ejector Handle Position during Controller or Peripheral Module Insertion

3. When you begin to feel resistance, push up on the injector/ejector handle to inject the controller fully into the chassis frame. Secure the controller front panel to the chassis using the controller front-panel mounting screws.
4. Connect the keyboard, mouse, and monitor to the appropriate connectors. Connect devices to ports as required by your system configuration.
5. Power on the chassis. Verify that the controller boots. If the controller does not boot, refer to your controller user manual.

Figure 2-4 shows a PXI controller installed in the system controller slot of a PXI-1036/PXI-1036DC chassis. You can place CompactPCI or PXI modules in any other slot.



**Figure 2-4.** NI PXI Controller Installed in a PXI-1036/PXI-1036DC Chassis

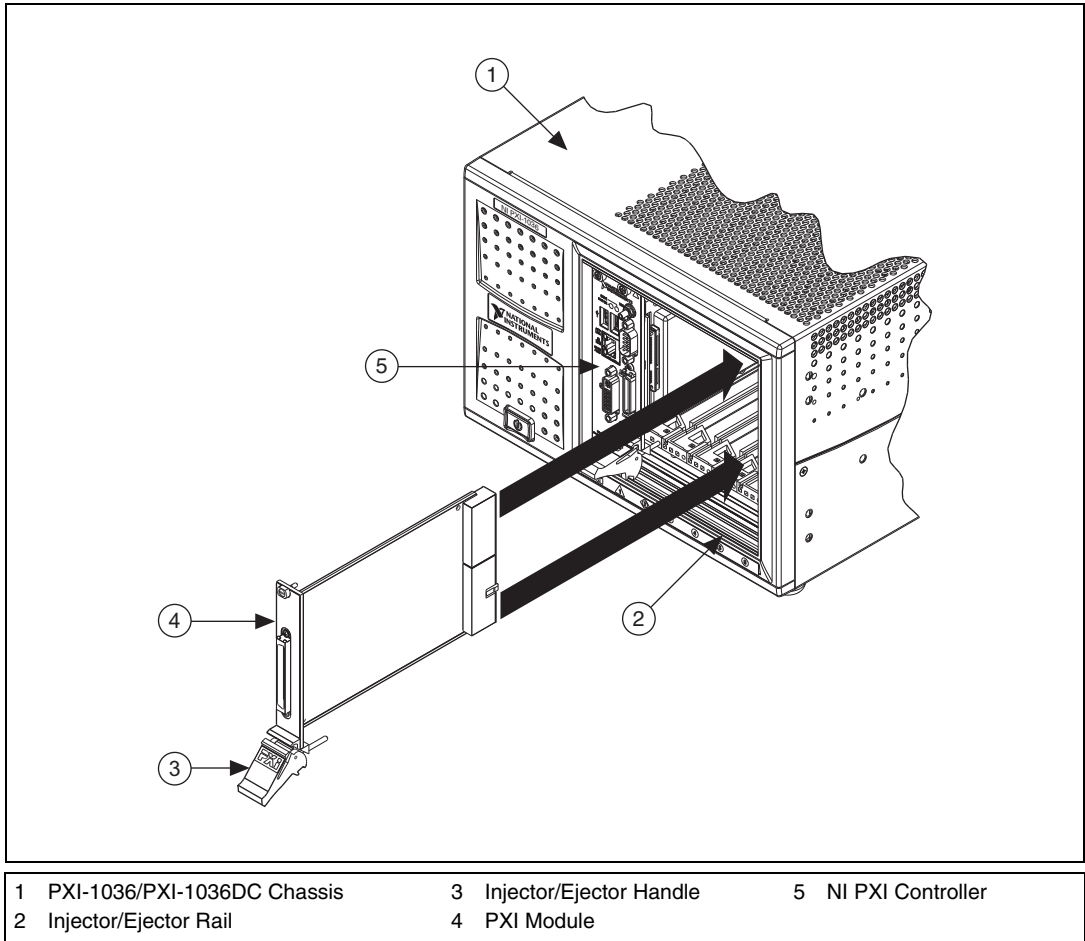
## Installing PXI Modules

Complete the following steps to install a module.

1. Make sure the power switch is in the Off (Standby) position.
2. Install a module into a chassis slot by first placing the module card edges into the front module guides (top and bottom), as shown in Figure 2-5. Slide the module to the rear of the chassis, making sure that the injector/ejector handle is pushed down as shown in Figure 2-3.



3. When you begin to feel resistance, push up on the injector/ejector handle to fully inject the module into the chassis frame. Secure the module front panel to the chassis using the module front-panel mounting screws.



**Figure 2-5.** Installing PXI or CompactPCI Modules

# PXI System Configuration with MAX

Configuration of the PXI system is handled through Measurement & Automation Explorer (MAX), included on the NI Driver CD-ROM packaged with your kit. MAX creates the `pxisys.ini` file that defines the layout and parameters of your PXI system. After installing the software on the NI Driver CD-ROM, the MAX icon will be present on the desktop. The configuration steps for single or multiple chassis systems are the same.

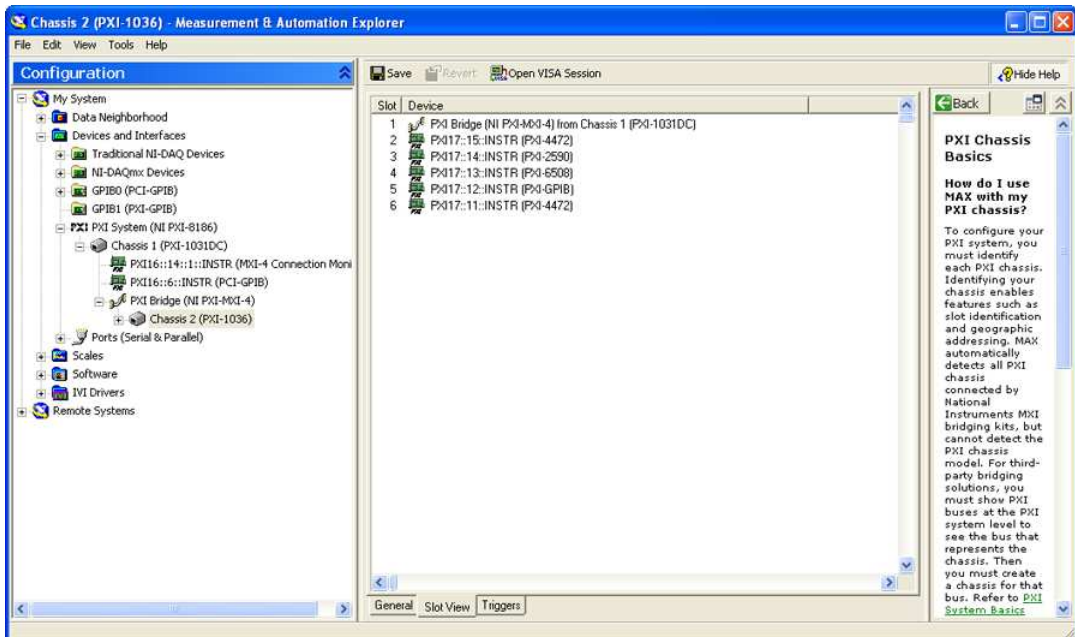


Figure 2-6. Chassis Configuration in MAX

## Basic PXI System Configuration

Refer to Figure 2-6 while completing the following steps:

1. Launch MAX.
2. In the **Configuration** tree, click the **Devices and Interfaces** branch to expand it.
3. If the PXI system controller has not yet been configured, it will be labeled **PXI System (Unidentified)**. Right-click this entry to display the context menu and then select the appropriate controller model from the **Identify As** submenu.

4. Click the **PXI System** controller, and the chassis (or multiple chassis, in a multi-chassis configuration) will be listed below it. Identify each chassis by right-clicking its entry and then selecting the appropriate chassis model through the **Identify As** submenu. Further expanding the **PXI System** branch will show all of the devices in the system that can be recognized by NI-VISA. After your controller and all of your chassis have been identified, the required `pxisys.ini` file will be complete.
5. Apply the chassis number labels (shown in Figure 2-7) included with your kit to each chassis in your PXI system, and write in the chassis number accordingly in the white space.



Figure 2-7. Chassis Number Label

## Trigger Configuration in MAX

Each chassis has one or more trigger buses, each with eight lines numbered 0 through 7 that can be reserved and routed statically or dynamically. Static reservation “pre-allocates” a trigger line to prevent its configuration by a user program. Dynamic reservation/routing/deallocation is performed *on the fly* within a user program based upon National Instruments APIs such as NI-DAQmx. Static reservation of trigger lines can be implemented by the user in MAX through the **Triggers** tab. Reserved trigger lines will not be used by PXI modules dynamically configured by programs such as NI-DAQmx. This prevents the instruments from double-driving the trigger lines, possibly damaging devices in the chassis.

Complete the following steps to reserve these trigger lines in MAX.

1. In the **Configuration** tree, click the PXI chassis branch you want to configure.
2. Click the **Triggers** tab at the bottom of the right-hand pane.
3. Select which trigger lines you want to statically reserve.
4. Click the **Apply** button.

## Using System Configuration and Initialization Files

---

The PXI specification allows many combinations of PXI chassis and system modules. To assist system integrators, the manufacturers of PXI chassis and system modules must document the capabilities of their products. The minimum documentation requirements are contained in `.ini` files, which consist of ASCII text. System integrators, configuration utilities, and device drivers can use these `.ini` files.

The capability documentation for the PXI-1036/PXI-1036DC chassis is contained in the `chassis.ini` file on the software media that comes with the chassis. The information in this file is combined with information about the system controller to create a single system initialization file called `pxisys.ini` (PXI System Initialization). The system controller manufacturer either provides a `pxisys.ini` file for the particular chassis model that contains the system controller or provides a utility that can read an arbitrary `chassis.ini` file and generate the corresponding `pxisys.ini` file. System controllers from National Instruments use MAX to generate the `pxisys.ini` file from the `chassis.ini` file.

Device drivers and other utility software read the `pxisys.ini` file to obtain system information. Device drivers should have no need to directly read the `chassis.ini` file. For detailed information regarding initialization files, refer to the PXI specification at [www.pxisa.org](http://www.pxisa.org).

---

# Maintenance

This chapter describes basic maintenance procedures you can perform on the PXI-1036 and PXI-1036DC chassis.



**Caution** Disconnect the power cables prior to servicing the chassis.

---

## DC Fuse Replacement (PXI-1036DC Only)

---

The PXI-1036DC is protected against over-current by a 30 A fuse on the rear of the chassis, as shown in Figure 1-3, *Rear View of the PXI-1036DC Chassis*. The fuse should only be replaced with a Wickmann 162.6385.530, Littlefuse 257 030, or equivalent. To remove the fuse, pull *straight out* from the chassis.

---

## Service Interval

---

Clean dust from the chassis exterior (and interior) as needed, based on the operating environment. Periodic cleaning increases reliability.

---

## Preparation

---

The information in this chapter is designed for use by qualified service personnel. Read the *Read Me First: Safety and Electromagnetic Compatibility* document included with your kit before attempting any procedures in this chapter.



**Caution** Many components within the chassis are susceptible to static discharge damage. Service the chassis only in a static-free environment. Observe standard handling precautions for static-sensitive devices while servicing the chassis. Always wear a grounded wrist strap or equivalent while servicing the chassis.

# Cleaning

---



**Caution** Always disconnect the AC power cable (and the DC power cable, if you are working with a PXI-1036DC chassis) before cleaning or servicing the chassis.

Cleaning procedures consist of exterior and interior cleaning of the chassis. Refer to your module user documentation for information on cleaning individual CompactPCI or PXI modules.

## Interior Cleaning

Use a dry, low-velocity stream of air to clean the interior of the chassis.  
Use a soft-bristle brush for cleaning around components.

## Exterior Cleaning



**Cautions** Avoid getting moisture inside the chassis during exterior cleaning, especially through the top vents. Use just enough moisture to dampen the cloth.

Do *not* wash the front- or rear-panel connectors or switches. Cover these components while cleaning the chassis.

Do *not* use harsh chemical cleaning agents; they may damage the chassis. Avoid chemicals that contain benzene, toluene, xylene, acetone, or similar solvents.

Clean the exterior surfaces of the chassis with a dry lint-free cloth or a soft-bristle brush. If any dirt remains, wipe with a cloth moistened in a mild soap solution. Remove any soap residue by wiping with a cloth moistened with clear water. Do *not* use abrasive compounds on any part of the chassis.

---

## Specifications



**Caution** If the PXI-1036/PXI-1036DC chassis is used in a manner inconsistent with the instructions or specifications listed by National Instruments, the protective features of the chassis may be impaired.



**Note** Specifications are subject to change without notice.

This appendix contains specifications for the PXI-1036 and PXI-1036DC chassis.

## PXI-1036 Chassis

---

### Electrical



**Caution** Overloading the circuits may damage supply wiring. Do not exceed the ratings on the equipment nameplate when connecting equipment to the supply circuit.

#### AC Input

Input voltage range..... 100–240 VAC

Operating voltage range<sup>1</sup> ..... 90–264 VAC

Input frequency ..... 50/60 Hz

Operating frequency range<sup>1</sup> ..... 47–63 Hz

Input current rating..... 4–2 A

Over-current protection..... 5 A fuse in power supply  
(no user-serviceable components  
inside chassis)

Efficiency ..... >70% at full load,  
normal input voltage

---

<sup>1</sup> The operating range is guaranteed by design.

Power disconnect .....The AC power cable provides main power disconnect. The front-panel power switch controls the internal chassis power supply that provides DC power to the CompactPCI/PXI backplane.

## DC Output

DC current capacity ( $I_{MP}$ )

Voltage	0–50 °C
+3.3 V	12 A
+5 V	17 A
+12 V	2 A
–12 V	0.8 A

Over-current protection .....All outputs protected from short circuit and overload

Over-voltage protection

Over-voltage at	Active Range	
	Minimum	Maximum
+3.3 V	3.76 V	4.3 V
+5 V	5.74 V	7.0 V
+12 V	13.4 V	15.6 V

## Chassis Cooling

Per slot cooling capacity .....25 W

Slot airflow direction .....P1 to P2, bottom of module to top of module

Module cooling

System .....Forced air circulation (positive pressurization) through a 101.1 CFM fan with HIGH/AUTO speed selector

Intake .....Bottom of chassis



Exhaust.....	Along rear, right side, and top of chassis
Power supply cooling	
System.....	Forced air circulation through integrated fan
Intake .....	Front and left side of chassis
Exhaust.....	Rear side of chassis

## Environmental

Operating location.....	Indoor use
Maximum altitude .....	2,000 m
Measurement Category .....	II
Pollution Degree .....	2

## Operating Environment

Ambient temperature range.....	0 to 50 °C (Tested in accordance with IEC-60068-2-1 and IEC-60068-2-2.)
Relative humidity range .....	20 to 80%, noncondensing (Tested in accordance with IEC-60068-2-56.)

## Storage Environment

Ambient temperature range.....	-20 to 70 °C (Tested in accordance with IEC-60068-2-1 and IEC-60068-2-2.)
Relative humidity range .....	10 to 95%, noncondensing (Tested in accordance with IEC-60068-2-56.)

## Shock and Vibration

Operational shock .....30 g peak, half-sine, 11 ms pulse  
(Tested in accordance with IEC-60068-2-27. Test profile developed in accordance with MIL-PRF-28800F.)

## Random Vibration

Operating .....5 to 500 Hz, 0.3 g<sub>rms</sub>

Nonoperating .....5 to 500 Hz, 2.4 g<sub>rms</sub>  
(Tested in accordance with IEC-60068-2-64. Nonoperating test profile exceeds the requirements of MIL-PRF-28800F, Class 3.)

## Acoustic Emissions

### Sound Pressure Level (at Operator Position)

Tested in accordance with ISO 7779.

PXI-1036

Auto fan (at 25 °C ambient) .....35.0 dBA

High fan .....51.1 dBA

### Sound Power

Tested in accordance with ISO 7779.

PXI-1036

Auto fan (at 25 °C ambient) .....43.4 dBA

High fan .....59.5 dBA

# PXI-1036DC Chassis

---

## Electrical



**Caution** Overloading the circuits may damage supply wiring. Do not exceed the ratings on the equipment nameplate when connecting equipment to the supply circuit.

### AC Input

Input voltage range.....	100–240 VAC
Operating voltage range <sup>1</sup> .....	90–264 VAC
Input frequency .....	50/60 Hz
Operating frequency range <sup>1</sup> .....	47–63 Hz
Input current rating.....	4–2 A
Over-current protection.....	6.3 A fuse in power supply (no user-serviceable components inside chassis)
Efficiency .....	65% minimum
Power disconnect .....	The AC power cable provides main power disconnect. The front-panel power switch controls the internal chassis power supply that provides DC power to the CompactPCI/PXI backplane.

### DC Input

Input voltage range.....	18–30 VDC
Input current rating.....	30–10 A
Efficiency .....	65% typical

---

<sup>1</sup> The operating range is guaranteed by design.

Power disconnect.....The DC power cable provides main power disconnect. The front-panel power switch controls the internal chassis power supply that provides DC power to the CompactPCI/PXI backplane.

## DC Output

DC current capacity ( $I_{MP}$ )

Voltage	0–50 °C
+3.3 V	12 A
+5 V	17 A
+12 V	2 A
–12 V	0.8 A



**Notes** The output power is derated  $-5 \text{ W}/^\circ\text{C}$  above  $45 \text{ }^\circ\text{C}$ .

The combined loading on +5 VDC and +3.3 VDC must not exceed 112 W.

For AC powered applications, the combined loading must not exceed 145.6 W.

Overcurrent protection.....All outputs protected from short circuit and overload

Overvoltage protection .....All outputs protected from overvoltage. Cycle the primary power and front power switch to restart.

## Chassis Cooling

Per slot cooling capacity.....25 W

Slot airflow direction .....P1 to P2, bottom of module to top of module

**Module cooling**

System.....	Forced air circulation (positive pressurization) through a 101.1 CFM fan with HIGH/AUTO speed selector
Intake .....	Bottom of chassis
Exhaust.....	Along rear, right side, and top of chassis

**Power supply cooling**

System.....	Forced air circulation through integrated fan
Intake .....	Front and left side of chassis
Exhaust.....	Rear side of chassis

**Environmental**

Operating location.....	Indoor use
Maximum altitude .....	2,000 m
Measurement Category .....	II
Pollution Degree .....	2

**Operating Environment**

Ambient temperature range.....	0 to 50 °C (Tested in accordance with IEC-60068-2-1 and IEC-60068-2-2.)
Relative humidity range .....	10 to 90%, noncondensing (Tested in accordance with IEC-60068-2-56.)

**Storage Environment**

Ambient temperature range.....	-20 to 70 °C (Tested in accordance with IEC-60068-2-1 and IEC-60068-2-2.)
--------------------------------	--

Relative humidity range.....5 to 95%, noncondensing  
(Tested in accordance with IEC-60068-2-56.)

## Shock and Vibration

Operational shock .....30 g peak, half-sine, 11 ms pulse  
(Tested in accordance with IEC-60068-2-27. Test profile developed in accordance with MIL-PRF-28800F.)

## Random Vibration

Operating .....5 to 500 Hz, 0.3 g<sub>rms</sub>

Nonoperating .....5 to 500 Hz, 2.4 g<sub>rms</sub>  
(Tested in accordance with IEC-60068-2-64. Nonoperating test profile exceeds the requirements of MIL-PRF-28800F, Class 3.)

## Acoustic Emissions

### Sound Pressure Level (at Operator Position)

Tested in accordance with ISO 7779.

PXI-1036DC

Auto fan (at 25 °C ambient) .....45.5 dBA  
High fan .....49.4 dBA

### Sound Power

Tested in accordance with ISO 7779.

PXI-1036DC

Auto fan (at 25 °C ambient) .....54.3 dBA  
High fan .....58.2 dBA

# Common Specifications

---

## Safety

This product is designed to meet the requirements of the following standards of safety for information technology equipment:

- IEC 61010-1, EN 61010-1
- UL 61010-1, CSA 61010-1



**Note** For UL and other safety certifications, refer to the product label or the [Online Product Certification](#) section.

## Electromagnetic Compatibility

This product meets the requirements of the following EMC standards for electrical equipment for measurement, control, and laboratory use:

- EN 61326 (IEC 61326): Class A emissions; Basic immunity
- EN 55011 (CISPR 11): Group 1, Class A emissions
- AS/NZS CISPR 11: Group 1, Class A emissions
- FCC 47 CFR Part 15B: Class A emissions
- ICES-001: Class A emissions



**Note** For the standards applied to assess the EMC of this product, refer to the [Online Product Certification](#) section.



**Note** For EMC compliance, operate this device with shielded cabling.

## CE Compliance

This product meets the essential requirements of applicable European Directives as follows:

- 2006/95/EC; Low-Voltage Directive (safety)
- 2004/108/EC; Electromagnetic Compatibility Directive (EMC)

## Online Product Certification

Refer to the product Declaration of Conformity (DoC) for additional regulatory compliance information. To obtain product certifications and the DoC for this product, visit [ni.com/certification](http://ni.com/certification), search by model number or product line, and click the appropriate link in the Certification column.

## Environmental Management

NI is committed to designing and manufacturing products in an environmentally responsible manner. NI recognizes that eliminating certain hazardous substances from our products is beneficial to the environment and to NI customers.

For additional environmental information, refer to the *NI and the Environment* Web page at [ni.com/environment](http://ni.com/environment). This page contains the environmental regulations and directives with which NI complies, as well as other environmental information not included in this document.

### Waste Electrical and Electronic Equipment (WEEE)



**EU Customers** At the end of the product life cycle, all products *must* be sent to a WEEE recycling center. For more information about WEEE recycling centers, National Instruments WEEE initiatives, and compliance with WEEE Directive 2002/96/EC on Waste and Electronic Equipment, visit [ni.com/environment/weee](http://ni.com/environment/weee).

### 电子信息产品污染控制管理办法（中国 RoHS）



**中国客户** National Instruments 符合中国电子信息产品中限制使用某些有害物质指令 (RoHS)。关于 National Instruments 中国 RoHS 合规性信息，请登录 [ni.com/environment/rohs\\_china](http://ni.com/environment/rohs_china)。(For information about China RoHS compliance, go to [ni.com/environment/rohs\\_china](http://ni.com/environment/rohs_china).)

## Backplane

Size .....3U-sized; one system slot  
(with one system expansion slot)  
and 5 peripheral slots.  
Compliant with IEEE 1101.10  
mechanical packaging.  
*PXI Hardware Specification,*  
*Revision 2.2* compliant. Accepts  
both PXI and CompactPCI 3U  
modules.



V(I/O) <sup>1</sup> .....	+5 V
Backplane bare-board material .....	UL 94 V-0
Backplane connectors .....	Conform to IEC 917 and IEC 1076-4-101, and are UL 94 V-0 rated

## 10 MHz System Reference Clock (10 MHz REF)

Maximum clock skew between slots .....	250 ps
Built-in 10 MHz clock Accuracy .....	±25 ppm (guaranteed over the operating temperature range)

## Mechanical

Overall dimensions (standard chassis) Height.....	177 mm (6.97 in.)
--	-------------------



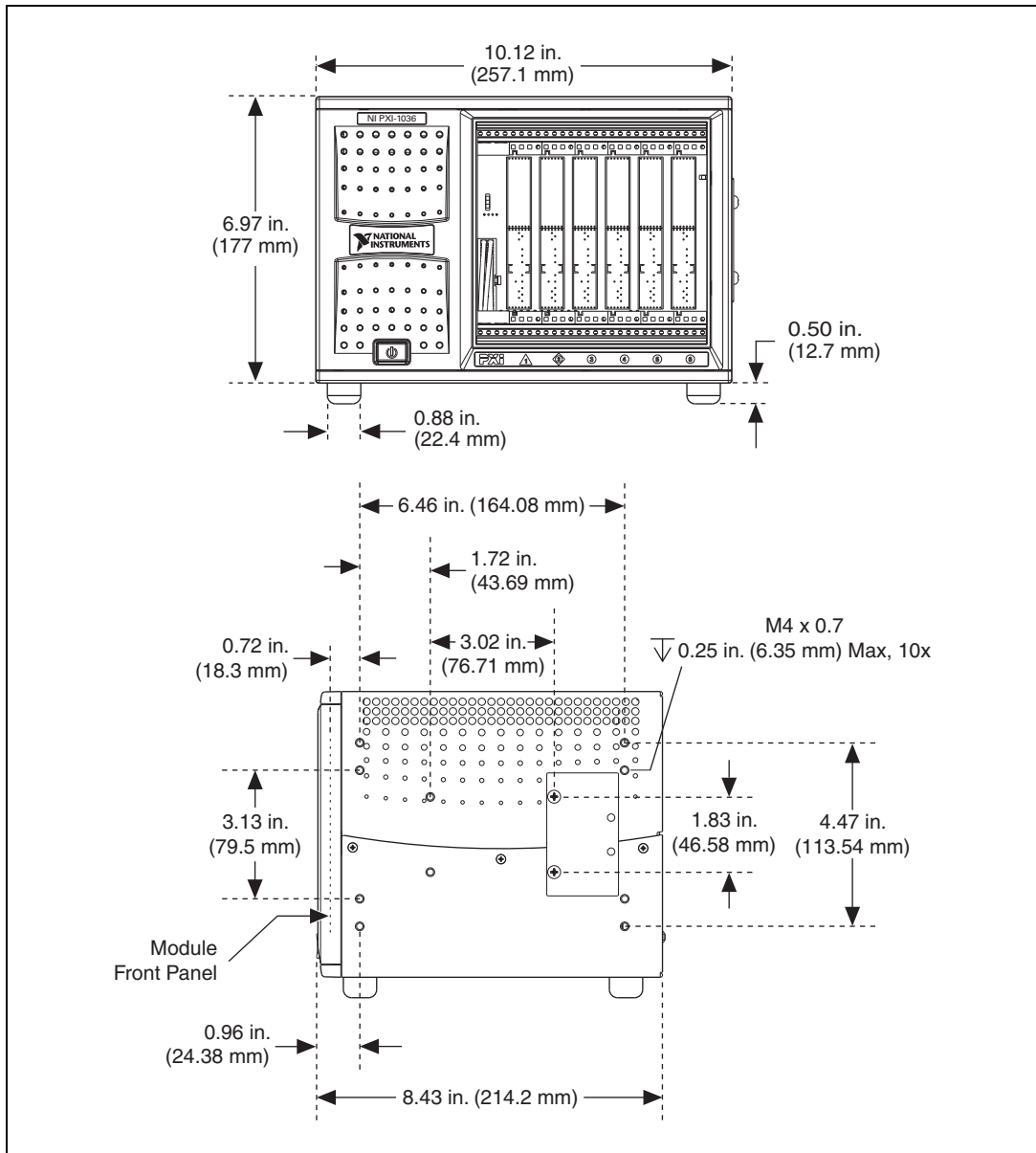
**Note** 12.7 mm (0.50 in.) is added to height when feet are installed.

Width .....	257.1 mm (10.12 in.)
Depth.....	212.8 mm (8.38 in.)
Weight.....	5 kg (11.0 lbs)
Chassis materials.....	Sheet Aluminum, Extruded Aluminum, Cold Rolled Steel, Nylon
Finish.....	Clear Chromate Conversion Coat on Aluminum Electrodeposited Nickel Plate Plate on Cold Rolled Steel Polyester Urethane Powder Paint

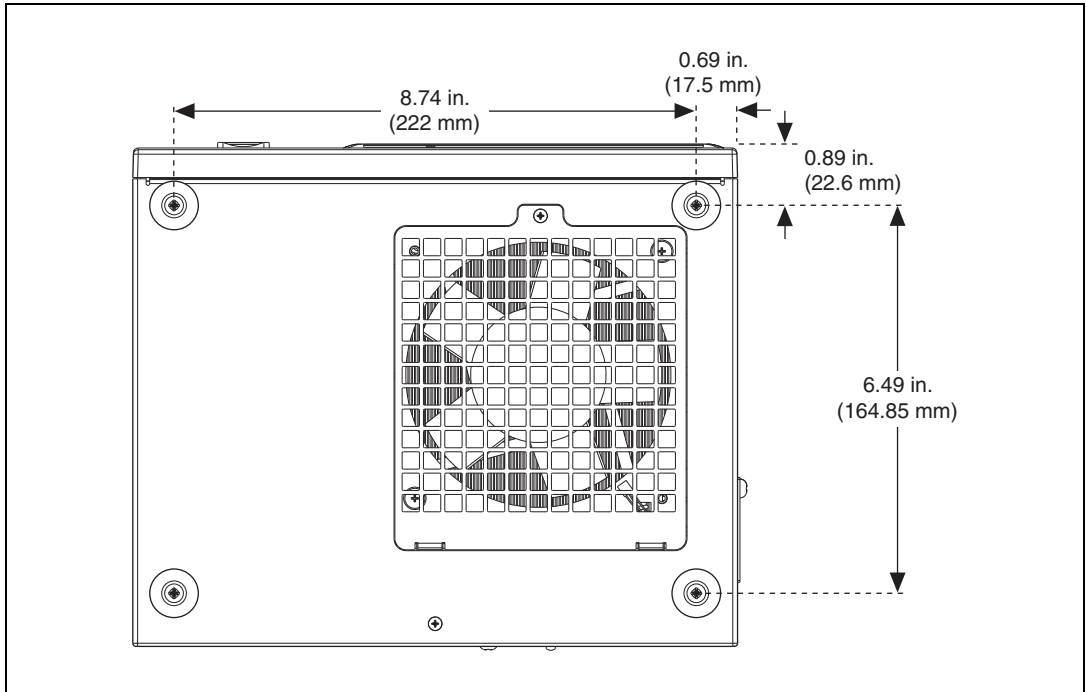
---

<sup>1</sup> V(I/O) is connected to the +5 V DC power plane, so the same specifications apply to V(I/O) and +5 V.

Figure A-1 and Figure A-2 show the PXI-1036/PXI-1036DC dimensions. The holes shown are for the installation of the optional rack-mount kits as shown in Figure A-3. Notice that the front and rear rack mounting holes (size M4) are symmetrical.

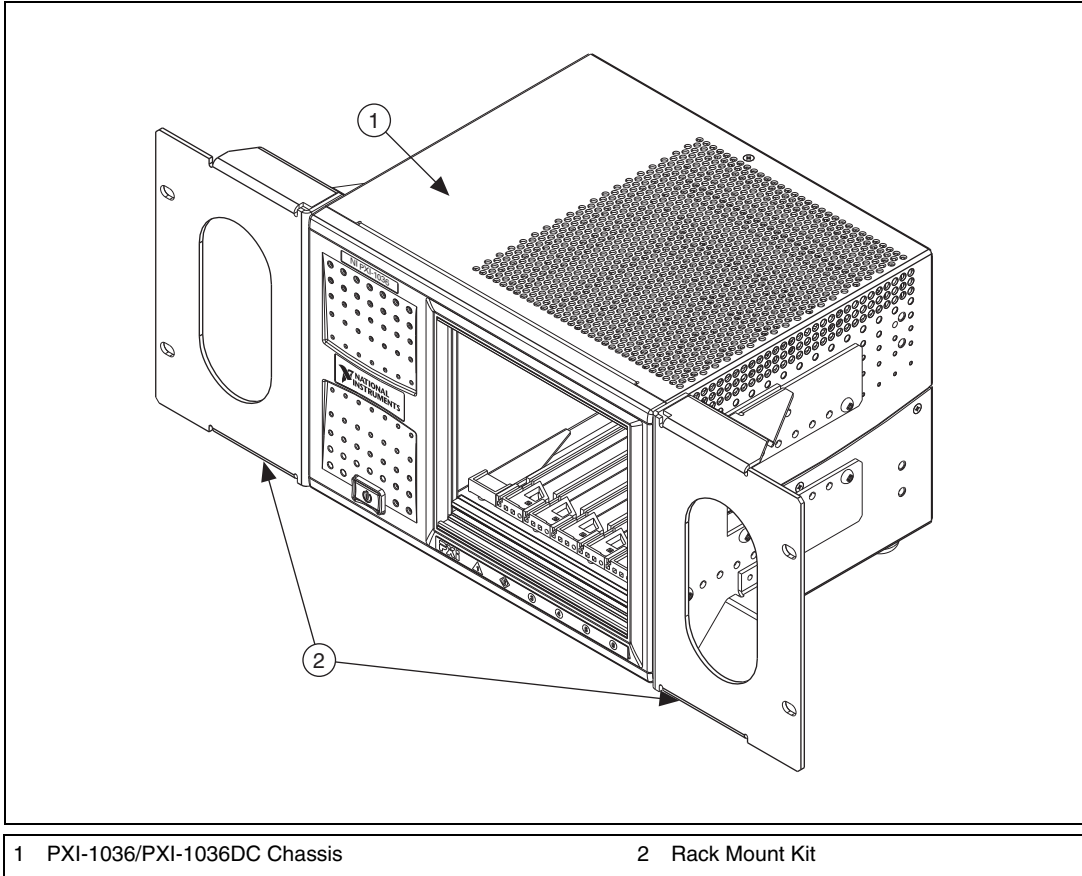


**Figure A-1.** PXI-1036/PXI-1036DC Dimensions (Front and Side) in Inches (mm)



**Figure A-2.** PXI-1036/PXI-1036DC Dimensions (Bottom) in Inches (mm)

Figure A-3 shows the PXI-1036/PXI-1036DC rack mount kit components.



**Figure A-3.** PXI-1036/PXI-1036DC Rack Mount Kit Components

---

## Pinouts

This appendix describes the P1 and P2 connector pinouts for the PXI-1036/PXI-1036DC backplane.

Table B-1 shows the P1 (J1) connector pinout for the System Controller slot.

Table B-2 shows the P2 (J2) connector pinout for the System Controller slot.

Table B-3 shows the P1 (J1) connector pinout for the star trigger slot.

Table B-4 shows the P2 (J2) connector pinout for the star trigger slot.

Table B-5 shows the P1 (J1) connector pinout for the peripheral slots.

Table B-6 shows the P2 (J2) connector pinout for the peripheral slots.



**Note** PXI signals are shown in bold.

**Table B-1.** P1 (J1) Connector Pinout for the System Controller Slot

Pin	Z	A	B	C	D	E	F
25	GND	5 V	REQ64#	ENUM#	3.3 V	5 V	GND
24	GND	AD[1]	5 V	V(I/O)	AD[0]	ACK64#	GND
23	GND	3.3 V	AD[4]	AD[3]	5 V	AD[2]	GND
22	GND	AD[7]	GND	3.3 V	AD[6]	AD[5]	GND
21	GND	3.3 V	AD[9]	AD[8]	M66EN	C/BE[0]#	GND
20	GND	AD[12]	GND	V(I/O)	AD[11]	AD[10]	GND
19	GND	3.3 V	AD[15]	AD[14]	GND	AD[13]	GND
18	GND	SERR#	GND	3.3 V	PAR	C/BE[1]#	GND
17	GND	3.3 V	IPMB_SCL	IPMB_SDA	GND	PERR#	GND
16	GND	DEVSEL#	GND	V(I/O)	STOP#	LOCK#	GND
15	GND	3.3 V	FRAME#	IRDY#	GND	TRDY#	GND
12–14	Key Area						
11	GND	AD[18]	AD[17]	AD[16]	GND	C/BE[2]#	GND
10	GND	AD[21]	GND	3.3 V	AD[20]	AD[19]	GND
9	GND	C/BE[3]#	GND	AD[23]	GND	AD[22]	GND
8	GND	AD[26]	GND	V(I/O)	AD[25]	AD[24]	GND
7	GND	AD[30]	AD[29]	AD[28]	GND	AD[27]	GND
6	GND	REQ0#	GND	3.3 V	CLK0	AD[31]	GND
5	GND	BRSVP1A5	BRSVP1B5	RST#	GND	GNT0#	GND
4	GND	IPMB_PWR	HEALTHY#	V(I/O)	INTP	INTS	GND
3	GND	INTA#	INTB#	INTC#	5 V	INTD#	GND
2	GND	TCK	5 V	TMS	TDO	TDI	GND
1	GND	5 V	-12 V	TRST#	+12 V	5 V	GND

**Table B-2.** P2 (J2) Connector Pinout for the System Controller Slot

Pin	Z	A	B	C	D	E	F
22	GND	GA4	GA3	GA2	GA1	GA0	GND
21	GND	CLK6	GND	RSV	RSV	RSV	GND
20	GND	CLK5	GND	RSV	GND	RSV	GND
19	GND	GND	GND	SMB_SDA	SMB_SCL	SMB_ALERT#	GND
18	GND	<b>PXI_TRIG3</b>	<b>PXI_TRIG4</b>	<b>PXI_TRIG5</b>	GND	<b>PXI_TRIG6</b>	GND
17	GND	<b>PXI_TRIG2</b>	GND	PRST#	REQ6#	GNT6#	GND
16	GND	<b>PXI_TRIG1</b>	<b>PXI_TRIG0</b>	DEG#	GND	<b>PXI_TRIG7</b>	GND
15	GND	<b>PXI_BRSVA15</b>	GND	FAL#	REQ5#	GNT5#	GND
14	GND	BP(I/O)	BP(I/O)	BP(I/O)	GND	BP(I/O)	GND
13	GND	BP(I/O)	GND	V(I/O)	BP(I/O)	BP(I/O)	GND
12	GND	BP(I/O)	BP(I/O)	BP(I/O)	GND	BP(I/O)	GND
11	GND	BP(I/O)	GND	V(I/O)	BP(I/O)	BP(I/O)	GND
10	GND	BP(I/O)	BP(I/O)	BP(I/O)	GND	BP(I/O)	GND
9	GND	BP(I/O)	GND	V(I/O)	BP(I/O)	BP(I/O)	GND
8	GND	BP(I/O)	BP(I/O)	BP(I/O)	GND	BP(I/O)	GND
7	GND	BP(I/O)	GND	V(I/O)	BP(I/O)	BP(I/O)	GND
6	GND	BP(I/O)	BP(I/O)	BP(I/O)	GND	BP(I/O)	GND
5	GND	BP(I/O)	64EN#	V(I/O)	BP(I/O)	BP(I/O)	GND
4	GND	V(I/O)	<b>PXI_BRSVB4</b>	BP(I/O)	GND	BP(I/O)	GND
3	GND	CLK4	GND	GNT3#	REQ4#	GNT4#	GND
2	GND	CLK2	CLK3	SYSEN#	GNT2#	REQ3#	GND
1	GND	CLK1	GND	REQ1#	GNT1#	REQ2#	GND

**Table B-3.** P1 (J1) Connector Pinout for the Star Trigger Slot

Pin	Z	A	B	C	D	E	F
25	GND	5 V	REQ64#	ENUM#	3.3 V	5 V	GND
24	GND	AD[1]	5 V	V(I/O)	AD[0]	ACK64#	GND
23	GND	3.3 V	AD[4]	AD[3]	5 V	AD[2]	GND
22	GND	AD[7]	GND	3.3 V	AD[6]	AD[5]	GND
21	GND	3.3 V	AD[9]	AD[8]	M66EN	C/BE[0]#	GND
20	GND	AD[12]	GND	V(I/O)	AD[11]	AD[10]	GND
19	GND	3.3 V	AD[15]	AD[14]	GND	AD[13]	GND
18	GND	SERR#	GND	3.3 V	PAR	C/BE[1]#	GND
17	GND	3.3 V	IPMB_SCL	IPMB_SDA	GND	PERR#	GND
16	GND	DEVSEL#	GND	V(I/O)	STOP#	LOCK#	GND
15	GND	3.3 V	FRAME#	IRDY#	BD_SEL#	TRDY#	GND
12–14	Key Area						
11	GND	AD[18]	AD[17]	AD[16]	GND	C/BE[2]#	GND
10	GND	AD[21]	GND	3.3 V	AD[20]	AD[19]	GND
9	GND	C/BE[3]#	IDSEL	AD[23]	GND	AD[22]	GND
8	GND	AD[26]	GND	V(I/O)	AD[25]	AD[24]	GND
7	GND	AD[30]	AD[29]	AD[28]	GND	AD[27]	GND
6	GND	REQ#	GND	3.3 V	CLK	AD[31]	GND
5	GND	BRSVP1A5	BRSVP1B5	RST#	GND	GNT#	GND
4	GND	IPMB_PWR	HEALTHY#	V(I/O)	INTP	INTS	GND
3	GND	INTA#	INTB#	INTC#	5 V	INTD#	GND
2	GND	TCK	5 V	TMS	TDO	TDI	GND
1	GND	5 V	–12 V	TRST#	+12 V	5 V	GND



**Table B-4.** P2 (J2) Connector Pinout for the Star Trigger Slot

Pin	Z	A	B	C	D	E	F
22	GND	GA4	GA3	GA2	GA1	GA0	GND
21	GND	PXI_LBR0	RSV	PXI_LBR1	PXI_LBR2	PXI_LBR3	GND
20	GND	PXI_LBR4	PXI_LBR5	PXI_STAR0	GND	PXI_STAR1	GND
19	GND	PXI_STAR2	RSV	PXI_STAR3	PXI_STAR4	PXI_STAR5	GND
18	GND	PXI_TRIG3	PXI_TRIG4	PXI_TRIG5	GND	PXI_TRIG6	GND
17	GND	PXI_TRIG2	GND	RSV	PXI_CLK10_IN	PXI_CLK10	GND
16	GND	PXI_TRIG1	PXI_TRIG0	RSV	GND	PXI_TRIG7	GND
15	GND	PXI_BRSVA15	GND	RSV	PXI_STAR6	PXI_LBR6	GND
14	GND	RSV	RSV	RSV	GND	RSV	GND
13	GND	RSV	GND	V(I/O)	RSV	RSV	GND
12	GND	RSV	RSV	RSV	GND	RSV	GND
11	GND	RSV	GND	V(I/O)	RSV	RSV	GND
10	GND	RSV	RSV	RSV	GND	RSV	GND
9	GND	RSV	GND	V(I/O)	RSV	RSV	GND
8	GND	RSV	RSV	RSV	GND	RSV	GND
7	GND	RSV	GND	V(I/O)	RSV	RSV	GND
6	GND	RSV	RSV	RSV	GND	RSV	GND
5	GND	RSV	GND	V(I/O)	RSV	RSV	GND
4	GND	V(I/O)	PXI_BRSVB4	RSV	GND	RSV	GND
3	GND	PXI_LBR7	GND	PXI_LBR8	PXI_LBR9	PXI_LBR10	GND
2	GND	PXI_LBR11	PXI_LBR12	UNC	PXI_STAR7	PXI_STAR8	GND
1	GND	PXI_STAR9	GND	PXI_STAR10	PXI_STAR11	PXI_STAR12	GND

**Table B-5.** P1 (J1) Connector Pinout for the Generic Peripheral Slot

Pin	Z	A	B	C	D	E	F
25	GND	5 V	REQ64#	ENUM#	3.3 V	5 V	GND
24	GND	AD[1]	5 V	V(I/O)	AD[0]	ACK64#	GND
23	GND	3.3 V	AD[4]	AD[3]	5 V	AD[2]	GND
22	GND	AD[7]	GND	3.3 V	AD[6]	AD[5]	GND
21	GND	3.3 V	AD[9]	AD[8]	M66EN	C/BE[0]#	GND
20	GND	AD[12]	GND	V(I/O)	AD[11]	AD[10]	GND
19	GND	3.3 V	AD[15]	AD[14]	GND	AD[13]	GND
18	GND	SERR#	GND	3.3 V	PAR	C/BE[1]#	GND
17	GND	3.3 V	IPMB_SCL	IPMB_SDA	GND	PERR#	GND
16	GND	DEVSEL#	GND	V(I/O)	STOP#	LOCK#	GND
15	GND	3.3 V	FRAME#	IRDY#	BD_SEL#	TRDY#	GND
12–14	Key Area						
11	GND	AD[18]	AD[17]	AD[16]	GND	C/BE[2]#	GND
10	GND	AD[21]	GND	3.3 V	AD[20]	AD[19]	GND
9	GND	C/BE[3]#	IDSEL	AD[23]	GND	AD[22]	GND
8	GND	AD[26]	GND	V(I/O)	AD[25]	AD[24]	GND
7	GND	AD[30]	AD[29]	AD[28]	GND	AD[27]	GND
6	GND	REQ#	GND	3.3 V	CLK	AD[31]	GND
5	GND	BRSVP1A5	BRSVP1B5	RST#	GND	GNT#	GND
4	GND	IPMB_PWR	HEALTHY#	V(I/O)	INTP	INTS	GND
3	GND	INTA#	INTB#	INTC#	5 V 5 V	INTD#	GND
2	GND	TCK	5 V	TMS	TDO	TDI	GND
1	GND	5 V	–12 V	TRST#	+12 V	5 V	GND

**Table B-6.** P2 (J2) Connector Pinout for the Generic Peripheral Slot

Pin	Z	A	B	C	D	E	F
22	GND	GA4	GA3	GA2	GA1	GA0	GND
21	GND	<b>PXI_LBR0</b>	RSV	<b>PXI_LBR1</b>	<b>PXI_LBR2</b>	<b>PXI_LBR3</b>	GND
20	GND	<b>PXI_LBR4</b>	<b>PXI_LBR5</b>	<b>PXI_LBL0</b>	GND	<b>PXI_LBL1</b>	GND
19	GND	<b>PXI_LBL2</b>	RSV	<b>PXI_LBL3</b>	<b>PXI_LBL4</b>	<b>PXI_LBL5</b>	GND
18	GND	<b>PXI_TRIG3</b>	<b>PXI_TRIG4</b>	<b>PXI_TRIG5</b>	GND	<b>PXI_TRIG6</b>	GND
17	GND	<b>PXI_TRIG2</b>	GND	RSV	<b>PXI_STAR</b>	<b>PXI_CLK10</b>	GND
16	GND	<b>PXI_TRIG1</b>	<b>PXI_TRIG0</b>	RSV	GND	<b>PXI_TRIG7</b>	GND
15	GND	<b>PXI_BRSVA15</b>	GND	RSV	<b>PXI_LBL6</b>	<b>PXI_LBR6</b>	GND
14	GND	RSV	RSV	RSV	GND	RSV	GND
13	GND	RSV	GND	V(I/O)	RSV	RSV	GND
12	GND	RSV	RSV	RSV	GND	RSV	GND
11	GND	RSV	GND	V(I/O)	RSV	RSV	GND
10	GND	RSV	RSV	RSV	GND	RSV	GND
9	GND	RSV	GND	V(I/O)	RSV	RSV	GND
8	GND	RSV	RSV	RSV	GND	RSV	GND
7	GND	RSV	GND	V(I/O)	RSV	RSV	GND
6	GND	RSV	RSV	RSV	GND	RSV	GND
5	GND	RSV	GND	V(I/O)	RSV	RSV	GND
4	GND	V(I/O)	64EN#	RSV	GND	RSV	GND
3	GND	<b>PXI_LBR7</b>	GND	<b>PXI_LBR8</b>	<b>PXI_LBR9</b>	<b>PXI_LBR10</b>	GND
2	GND	<b>PXI_LBR11</b>	<b>PXI_LBR12</b>	UNC	<b>PXI_LBL7</b>	<b>PXI_LBL8</b>	GND
1	GND	<b>PXI_LBL9</b>	GND	<b>PXI_LBL10</b>	<b>PXI_LBL11</b>	<b>PXI_LBL12</b>	GND



---

# Technical Support and Professional Services

Visit the following sections of the award-winning National Instruments Web site at [ni.com](http://ni.com) for technical support and professional services:

- **Support**—Technical support at [ni.com/support](http://ni.com/support) includes the following resources:
  - **Self-Help Technical Resources**—For answers and solutions, visit [ni.com/support](http://ni.com/support) for software drivers and updates, a searchable KnowledgeBase, product manuals, step-by-step troubleshooting wizards, thousands of example programs, tutorials, application notes, instrument drivers, and so on. Registered users also receive access to the NI Discussion Forums at [ni.com/forums](http://ni.com/forums). NI Applications Engineers make sure every question submitted online receives an answer.
  - **Standard Service Program Membership**—This program entitles members to direct access to NI Applications Engineers via phone and email for one-to-one technical support as well as exclusive access to on demand training modules via the Services Resource Center. NI offers complementary membership for a full year after purchase, after which you may renew to continue your benefits.

For information about other technical support options in your area, visit [ni.com/services](http://ni.com/services), or contact your local office at [ni.com/contact](http://ni.com/contact).

- **Training and Certification**—Visit [ni.com/training](http://ni.com/training) for self-paced training, eLearning virtual classrooms, interactive CDs, and Certification program information. You also can register for instructor-led, hands-on courses at locations around the world.
- **System Integration**—If you have time constraints, limited in-house technical resources, or other project challenges, National Instruments Alliance Partner members can help. To learn more, call your local NI office or visit [ni.com/alliance](http://ni.com/alliance).

- **Declaration of Conformity (DoC)**—A DoC is our claim of compliance with the Council of the European Communities using the manufacturer’s declaration of conformity. This system affords the user protection for electromagnetic compatibility (EMC) and product safety. You can obtain the DoC for your product by visiting [ni.com/certification](http://ni.com/certification).
- **Calibration Certificate**—If your product supports calibration, you can obtain the calibration certificate for your product at [ni.com/calibration](http://ni.com/calibration).

If you searched [ni.com](http://ni.com) and could not find the answers you need, contact your local office or NI corporate headquarters. Phone numbers for our worldwide offices are listed at the front of this manual. You also can visit the Worldwide Offices section of [ni.com/niglobal](http://ni.com/niglobal) to access the branch office Web sites, which provide up-to-date contact information, support phone numbers, email addresses, and current events.

# Glossary

---

Symbol	Prefix	Value
p	pico	$10^{-12}$
n	nano	$10^{-9}$
$\mu$	micro	$10^{-6}$
m	milli	$10^{-3}$
k	kilo	$10^3$
M	mega	$10^6$
G	giga	$10^9$
T	tera	$10^{12}$

## Symbols

°	Degrees
$\geq$	Equal or greater than
$\leq$	Equal or less than
%	Percent
$\Omega$	Ohms

## A

A	Amperes
AC	Alternating current
ANSI	American National Standards Institute
AUTO	Automatic fan speed control
AWG	American Wire Gauge

## B

backplane                      An assembly, typically a printed circuit board, with connectors and signal paths that bus the connector pins

## C

C                                  Celsius

cfm                                Cubic feet per minute

CFR                                Code of Federal Regulations

cm                                  Centimeters

CompactPCI                      An adaptation of the Peripheral Component Interconnect (PCI) Specification 2.1 or later for industrial and/or embedded applications requiring a more robust mechanical form factor than desktop PCI. It uses industry standard mechanical components and high-performance connector technologies to provide an optimized system intended for rugged applications. It is electrically compatible with the PCI Specification, which enables low-cost PCI components to be utilized in a mechanical form factor suited for rugged environments.

CSA                                 Canadian Standards Association

## D

daisy-chain                        A method of propagating signals along a bus, in which the devices are prioritized on the basis of their position on the bus

DC                                  Direct current

DoC                                 Declaration of Conformity

## E

efficiency                         Ratio of output power to input power, expressed as a percentage

EIA                                 Electronic Industries Association

embedded system controller      A module configured for installation in slot 1 of a PXI chassis. This device is unique in the PXI system in that it performs the system controller functions, including clock sourcing and arbitration for data transfers across the backplane. Installing such a device into any other slot can damage the device, the PXI backplane, or both.

EMC      Electromagnetic Compatibility

EMI      Electromagnetic Interference

## F

FCC      Federal Communications Commission

filler panel      A blank module front panel used to fill empty slots in the chassis

## G

g      (1) grams; (2) a measure of acceleration approximately equal to  $9.8 \text{ m/s}^2$

GPIB      General Purpose Interface Bus (IEEE 488)

$g_{\text{rms}}$       A measure of random vibration; the root mean square of acceleration levels in a random vibration test profile

## H

hr      Hours

Hz      Hertz; cycles per second

## I

IEC      International Electrotechnical Commission; an organization that sets international electrical and electronics standards

IEEE      Institute of Electrical and Electronics Engineers

$I_{\text{MP}}$       Mainframe peak current



in. Inches

inhibit To turn off

## **J**

jitter A measure of the small, rapid variations in clock transition times from their nominal regular intervals. Units: seconds RMS.

## **K**

kg Kilograms

km Kilometers

## **L**

lb Pounds

load regulation The maximum steady-state percentage that a DC voltage output will change as a result of a step change from no-load to full-load output current

## **M**

m Meters

MAX NI Measurement & Automation Explorer, the utility that allows you to configure and test your PXI system

MHz Megahertz. One million Hertz; one Hertz equals one cycle per second.

ms Millisecond, one thousandth of a second ( $10^{-3}$ )

## **N**

NEMA National Electrical Manufacturers Association

NI National Instruments

NI-DAQmx	National Instruments driver that controls the operation of National Instruments data acquisition (DAQ) devices
NI-VISA	National Instruments implementation of the VISA (Virtual Instrument System Architecture) I/O standard. NI-VISA provides support for the VISA API, and also provides VISAIC, a utility for instrument configuration and I/O function execution.
ns	Nanosecond, one billionth of a second ( $10^{-9}$ )
<b>P</b>	
ppm	Parts-per-million
PXI	PCI eXtensions for Instrumentation. PXI is an implementation of CompactPCI with added electrical features that meet the high performance requirements of instrumentation applications by providing triggering, local buses, and system clock capabilities.
PXI_CLK10	10 MHz PXI system reference clock
<b>R</b>	
RMS	Root mean square
<b>S</b>	
s	Seconds
skew	Deviation in signal transmission times
slot blocker	An assembly installed into an empty slot to improve the airflow in adjacent slots
ST	Star trigger
standby	The backplane is unpowered (off), but the chassis is still connected to AC power mains.

star trigger slot                      This slot is located at slot 2 and has a dedicated trigger line between each peripheral slot. Use this slot for a module with ST functionality that can provide individual triggers to all other peripherals.

system reference clock                A 10 MHz clock, also called PXI\_CLK10, that is distributed to all peripheral slots in the chassis. The system reference clock can be used for synchronization of multiple modules in a measurement or control system. The PXI backplane specification defines implementation guidelines for PXI\_CLK10.

## **T**

TTL                                        Transistor-transistor logic

## **U**

UL                                         Underwriter's Laboratories

## **V**

V    Volts

VAC                                        Volts alternating current, or  $V_{\text{rms}}$

$V_{\text{pp}}$                                         Peak-to-peak voltage

## **W**

W    Watts

# Index

---

## A

AC power cables (table), 1-2

## B

backplane

- interoperability with CompactPCI, 1-6
- local bus, 1-7
- overview, 1-6
- peripheral slots, 1-7
- specifications, A-10
- star trigger (ST) slot, 1-7
- system reference clock, 1-8
- trigger bus, 1-8

## C

- cables, power (table), 1-2
- calibration certificate (NI resources), C-2
- CE compliance specifications, A-9
- chassis initialization file, 2-12
- chassis number label (figure), 2-11
- CompactPCI
  - installing modules (figure), 2-9
  - interoperability with PXI-1036
    - backplane, 1-6
  - interoperability with PXI-1036DC
    - backplane, 1-6
- configuration. *See* installation, configuration, and operation
- conventions used in the manual, *vii*
- cooling
  - air cooling of PXI-1036, 2-2
  - air cooling of PXI-1036DC, 2-2
  - air intake (figure), 2-3
  - filler panel installation, 2-3
  - setting fan speed, 2-3

## D

DC

- power cable, 1-6
- power up, testing, 2-5

Declaration of Conformity (NI resources), C-2

diagnostic tools (NI resources), C-1

dimensions (figure), A-12, A-13

documentation

- conventions used in manual, *vii*
- NI resources, C-1
- related documentation, *viii*

drivers (NI resources), C-1

## E

electromagnetic compatibility  
specifications, A-9

EMC filler panel kit, 1-5

environmental management specifications, A-10

examples (NI resources), C-1

## F

fan, setting speed, 2-3

filler panel installation, 2-3

## G

ground, connecting, 2-4

## H

handle/feet kit, 1-5

help, technical support, C-1

**I**

- installation, configuration, and operation
  - chassis initialization file, 2-12
  - configuration in MAX (figure), 2-10
  - connecting safety ground, 2-4
  - filler panel installation, 2-3
  - installing a PXI controller, 2-6
  - module installation, 2-7, 2-8
    - CompactPCI or PXI modules (figure), 2-9
    - injector/ejector handle position (figure), 2-7
  - PXI configuration in MAX, 2-10
    - trigger configuration, 2-11
  - PXI controller installed in a PXI-1036
    - chassis (figure), 2-8
  - PXI controller installed in a PXI-1036DC
    - chassis (figure), 2-8
  - rack mounting, 2-4
  - setting fan speed, 2-3
  - site considerations, 2-2
  - testing power up, 2-4
    - DC, 2-5
  - unpacking
    - PXI-1036, 1-1
    - PXI-1036DC, 1-1
- instrument drivers (NI resources), C-1
- interoperability with CompactPCI, 1-6

**K**

- key features, 1-2
- KnowledgeBase, C-1

**L**

- local bus
  - routing, 1-7
  - star trigger and local bus routing (figure), 1-8

**M**

- maintenance of PXI-1036
  - cleaning
    - exterior cleaning, 3-2
    - interior cleaning, 3-2
  - preparation, 3-1
  - service interval, 3-1
  - static discharge damage (caution), 3-1
- maintenance of PXI-1036DC
  - cleaning
    - exterior cleaning, 3-2
    - interior cleaning, 3-2
  - preparation, 3-1
  - service interval, 3-1
  - static discharge damage (caution), 3-1
- mechanical specifications, A-11

**N**

- National Instruments support and services, C-1

**O**

- optional equipment, 1-5

**P**

- P1 (J1) connector
  - peripheral slot (table), B-6
  - star trigger slot (table), B-4
  - system controller slot (table), B-2
- P2 (J2) connector
  - peripheral slot (table), B-7
  - star trigger slot (table), B-5
  - system controller slot (table), B-3
- peripheral slots
  - overview, 1-7
  - P1 (J1) connector pinouts (table), B-6
  - P2 (J2) connector pinouts (table), B-7

- pinouts, B-1
  - P1 (J1) connector
    - peripheral slot (table), B-6
    - star trigger slot (table), B-4
    - system controller slot (table), B-2
  - P2 (J2) connector
    - peripheral slot (table), B-7
    - star trigger slot (table), B-5
    - system controller slot (table), B-3
- power cables (table), 1-2
- power supply
  - connecting to, 2-4
  - connecting to DC, 2-5
- power switch, 2-5
- power up, testing, 2-4
- programming examples (NI resources), C-1
- PXI controller, 2-6
  - installing in a PXI-1036 chassis (figure), 2-8
  - installing in a PXI-1036DC chassis (figure), 2-8
- PXI subsystem
  - star trigger and local bus routing (figure), 1-8
- PXI\_CLK10, 1-8
- PXI\_CLK10\_IN pin, 1-8
- PXI-1036
  - backplane
    - interoperability with CompactPCI, 1-6
    - local bus, 1-7
    - overview, 1-6
    - peripheral slots, 1-7
    - star trigger (ST) slot, 1-7
    - system reference clock, 1-8
    - trigger bus, 1-8
  - bottom view of chassis, 1-5
  - EMC filler panel kit, 1-5
  - fan speed, setting, 2-3
  - front view (figure), 1-3
  - handle/feet kit, 1-5
  - installation. *See* installation, configuration, and operation
  - key features, 1-2
  - maintenance. *See* maintenance of PXI-1036
  - module cooling air intake (figure), 2-3
  - optional equipment, 1-5
  - rack mount kits, 1-5
  - rack mounting, 2-4
  - rear view of chassis, 1-4
  - safety ground, connecting, 2-4
  - system controller slot
    - description, 1-7
- PXI-1036DC
  - backplane
    - interoperability with CompactPCI, 1-6
    - local bus, 1-7
    - overview, 1-6
    - peripheral slots, 1-7
    - star trigger (ST) slot, 1-7
    - system reference clock, 1-8
    - trigger bus, 1-8
  - fan speed, setting, 2-3
  - key features, 1-2
  - module cooling air intake (figure), 2-3
  - optional equipment, 1-5
  - rack mount kits, 1-5
  - rack mounting, 2-4
  - rear view of chassis, 1-4
  - safety ground, connecting, 2-4

## R

- rack mount kit dimensions (figure), A-14
- rack mount kits, 1-5
- rack mounting, 2-4
- related documentation, *viii*

## S

### safety

- and caution notices, 2-1
- ground, connecting, 2-4

### safety specifications, A-9

### service interval, 3-1

### setting fan speed, 2-3

### Slot, B-5

### software (NI resources), C-1

### specifications

- backplane, A-10
- CE compliance, A-9
- dimensions (figure), A-12, A-13
- electromagnetic compatibility, A-9
- environmental management, A-10
- mechanical, A-11
- rack mount kit dimensions (figure), A-14
- safety, A-9
- system reference clock, A-11

### specifications, PXI-1036

- acoustic emissions, A-4
  - sound power, A-4
  - sound pressure level (at operator position), A-4

### chassis cooling, A-2

### electrical

- AC input, A-1
- DC output, A-2

### environmental, A-3

### shock and vibration, A-4

### specifications, PXI-1036DC

- acoustic emissions, A-8
  - sound power, A-8
  - sound pressure level (at operator position), A-8

### chassis cooling, A-6

### electrical

- AC input, A-5
- DC input, A-5
- DC output, A-6

### environmental, A-7

### shock and vibration, A-8

### star trigger (ST) slot

#### description, 1-7

#### P1 (J1) connector pinouts (table), B-4

#### P2 (J2) connector pinouts (table), B-5

#### star trigger and local bus routing (figure), 1-8

### support, technical, C-1

### system controller slot

#### description, 1-7

#### P1 (J1) connector pinouts (table), B-2

#### P2 (J2) connector pinouts (table), B-3

### system reference clock, 1-8

### system reference clock specifications, A-11

## T

### technical support, C-1

### testing power up, 2-4

#### DC, 2-5

### training and certification (NI resources), C-1

### trigger bus, 1-8

### troubleshooting (NI resources), C-1

## U

### unpacking

#### PXI-1036, 1-1

#### PXI-1036DC, 1-1

## W

### Web resources, C-1