

## COMPREHENSIVE SERVICES

We offer competitive repair and calibration services, as well as easily accessible documentation and free downloadable resources.

## SELL YOUR SURPLUS

We buy new, used, decommissioned, and surplus parts from every NI series. We work out the best solution to suit your individual needs.

 Sell For Cash    Get Credit    Receive a Trade-In Deal

## OBSOLETE NI HARDWARE IN STOCK & READY TO SHIP

We stock **New**, **New Surplus**, **Refurbished**, and **Reconditioned** NI Hardware.



*Bridging the gap between the manufacturer and your legacy test system.*

 1-800-915-6216

 [www.apexwaves.com](http://www.apexwaves.com)

 [sales@apexwaves.com](mailto:sales@apexwaves.com)

*All trademarks, brands, and brand names are the property of their respective owners.*

**Request a Quote**

 **CLICK HERE**

**PXI-1036**

## INSTALLATION GUIDE

# PXI and PXI Express Chassis Fan Replacement

This guide describes how to replace the fan on a PXI and PXI Express chassis.



**Cautions** Make sure to unplug the power cord before replacing the fan.

Only trained service personnel should replace the fan.

## 4–6 and 9 Slot Chassis Fan Replacement

---



**Note** Fan replacement is supported only on chassis with specific assembly numbers. The supported model numbers are listed below, followed by their supported assembly numbers in parentheses. The *x* denotes the assembly letter revision.

Before replacing the fan, be sure to check the model and assembly numbers on the back of your PXI chassis. Replace the fan only if the model and assembly numbers are on the following list. Refer to the [NI PXI-103x and NI PXIe-1073 Chassis Fan Replacement](#) section for information about previous revisions.

- NI PXI-1031 (190871x-01, Revision L and newer)
- NI PXI-1031DC (191746x-01, Revision H and newer)
- NI PXI-1033 (194918x-01, Revision E and newer)
- NI PXI-1036 (192592x-01, Revision H and newer)
- NI PXI-1036DC (192593x-01, Revision F and newer)
- NI PXIe-1071 (195659x-01L)
- NI PXIe-1073 (196695x-01, Revision D and newer)
- NI PXIe-1078 (199485x-01L)

Refer to Figure 1 and the following steps for installation and removal instructions.

# NI PXI-103x and NI PXIe-1073 Chassis Fan Replacement

---

This section describes how to install the NI PXI-103x chassis fan replacement kit for the PXI-1031, PXI-1031DC, PXI-1033, PXI-1036, PXI-1036DC, and PXIe-1073 chassis.



**Note** Fan replacement is supported only on chassis with specific assembly numbers. The supported model numbers are listed below, followed by their supported assembly numbers in parentheses. The *x* denotes the assembly letter revision.

Before replacing the fan, be sure to check the model and assembly numbers on the back of your PXI chassis. Replace the fan only if the model and assembly numbers are on the following list.

- NI PXI-1031 (190871x-01, Revision H through K)
- NI PXI-1031DC (191746x-01, Revision E through G)
- NI PXI-1033 (194918x-01, Revision A through D)
- NI PXI-1036 (192592x-01, Revision D through G)
- NI PXI-1036DC (192593x-01, Revision C through E)
- NI PXIe-1073 (196695x-01, Revision A through C)

Refer to Figure 5 and the following steps for installation and removal instructions.

Figure 1 shows the parts you must remove to access the fan. Refer to the following steps for installation and removal instructions.

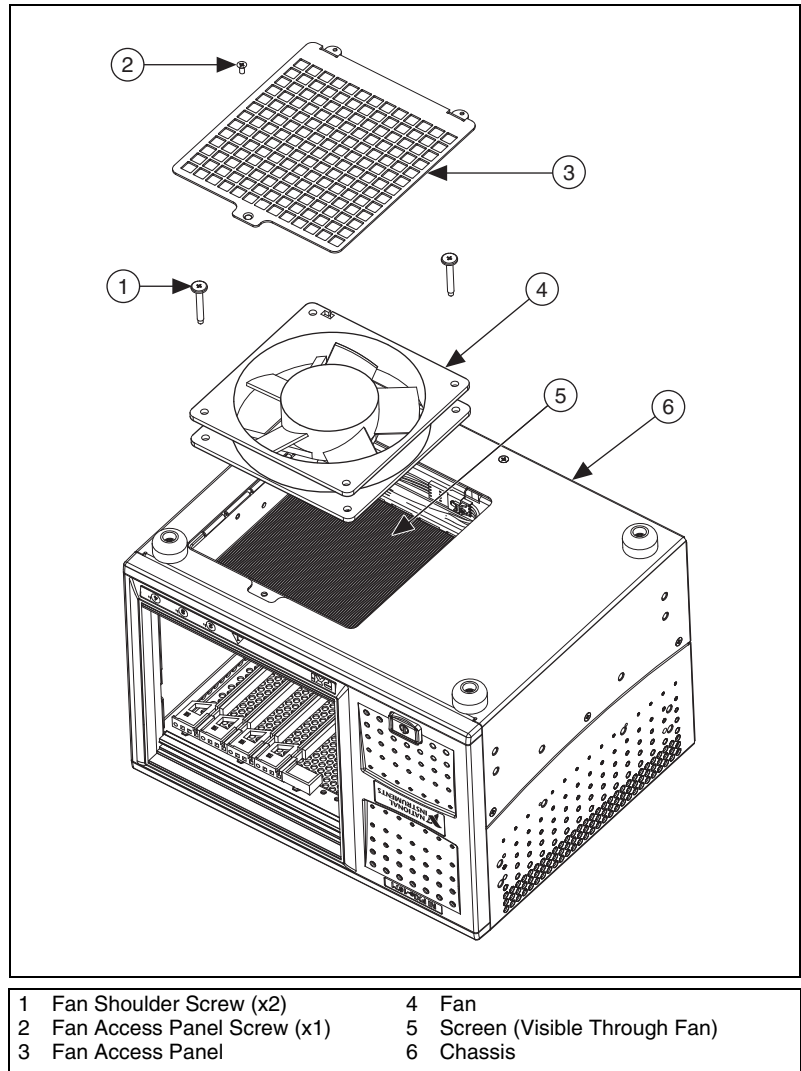
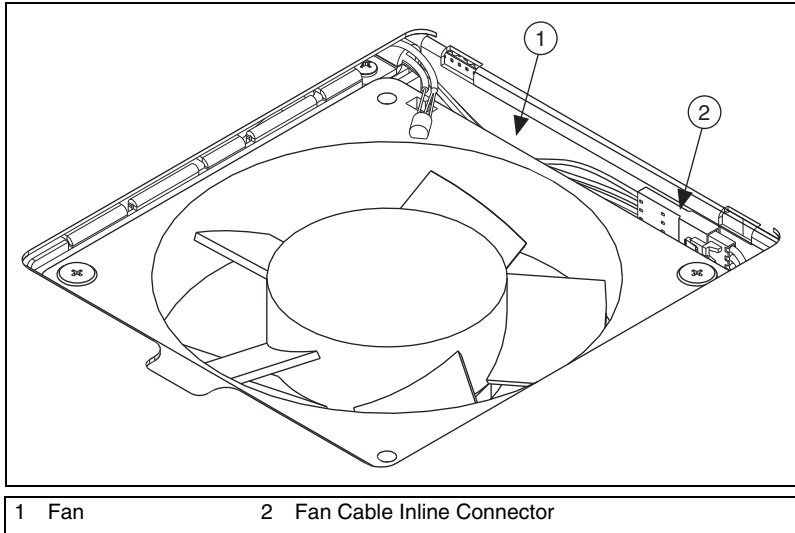

**Figure 1.** PXI Express Chassis Part Locations (Chassis Shown Upside Down)

Complete the following steps to replace the fan (refer to the previous figure for parts locations):

1. Locate the fan access panel on the bottom of the chassis. Remove the access panel screw and the access panel.
2. Remove the two fan shoulder screws, shown in Figure 1, that fasten the fan. Be careful not to lose the screws.
3. Remove the fan.

4. Disconnect the fan cable from the inline connector. The connector is shown in Figure 2.



**Figure 2.** Fan Cable Inline Connector

5. Connect the new fan to the inline connector. Place the fan inside the fan bracket with the square slot oriented as shown in Figure 3. The air flow direction is into the chassis, so the plastic grill and label on the fan should face toward the PXI card cage.

Place the screen below the fan (see Figure 1 for screen location). Ensure that the loose screen doesn't fall out. If the screen does fall out, return it to its position under the fan.

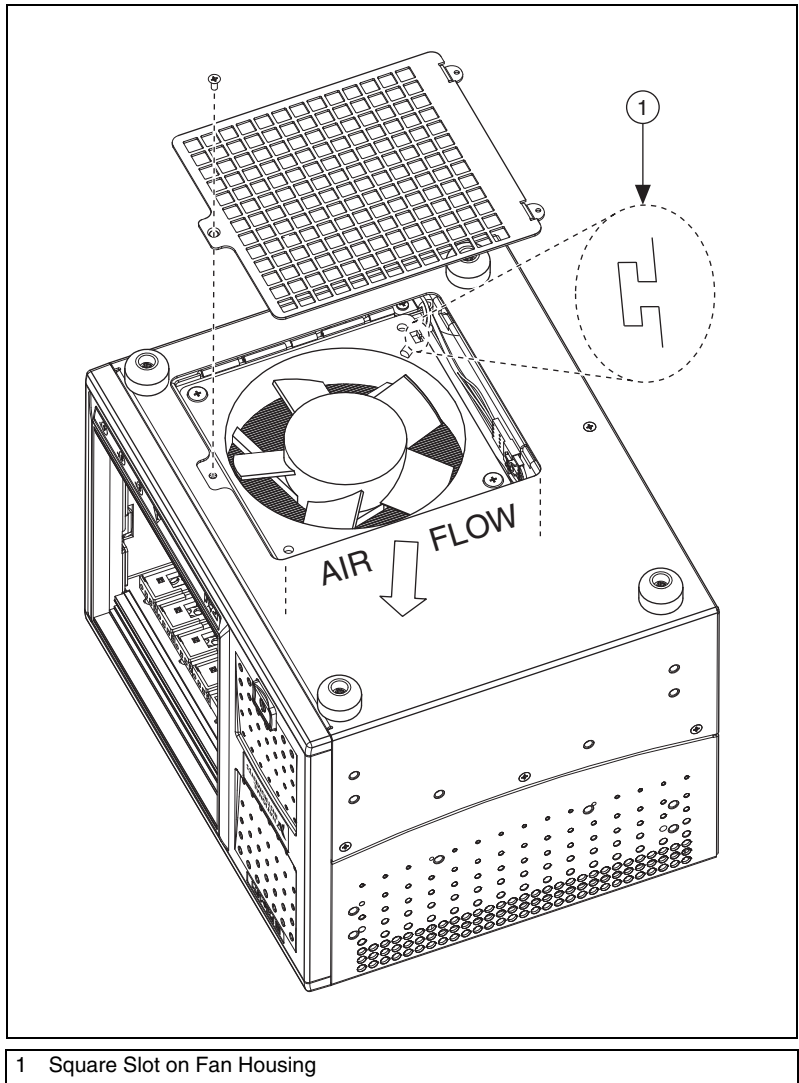

**Figure 3.** Square Slot on Fan Housing

6. Reinstall the two shoulder screws.

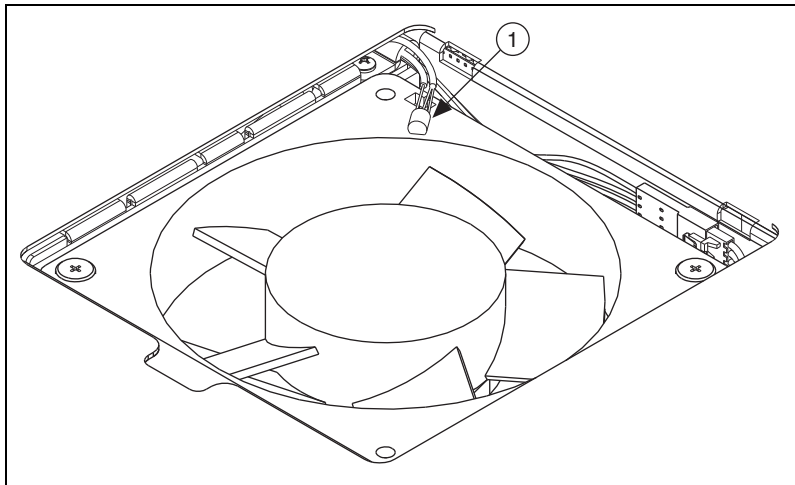

1 Thermistor wire

**Figure 4.** Thermistor Wire

7. Tighten the shoulder screws to between 3.0 lb · in. minimum torque and 3.6 lb · in. maximum torque.



**Caution** Orient the thermistor wire, as shown in Figure 4, before replacing the fan access panel.

8. Place the fan access panel over the opening. Insert and tighten the access panel screw to between 3.0 lb · in. minimum torque and 3.6 lb · in. maximum torque.



**Caution** Reorient the chassis to an upright position and ensure there are no loose parts prior to plugging in the power cord.

Figure 5 shows the parts you must remove to access the fan. Refer to the following steps for installation and removal instructions.

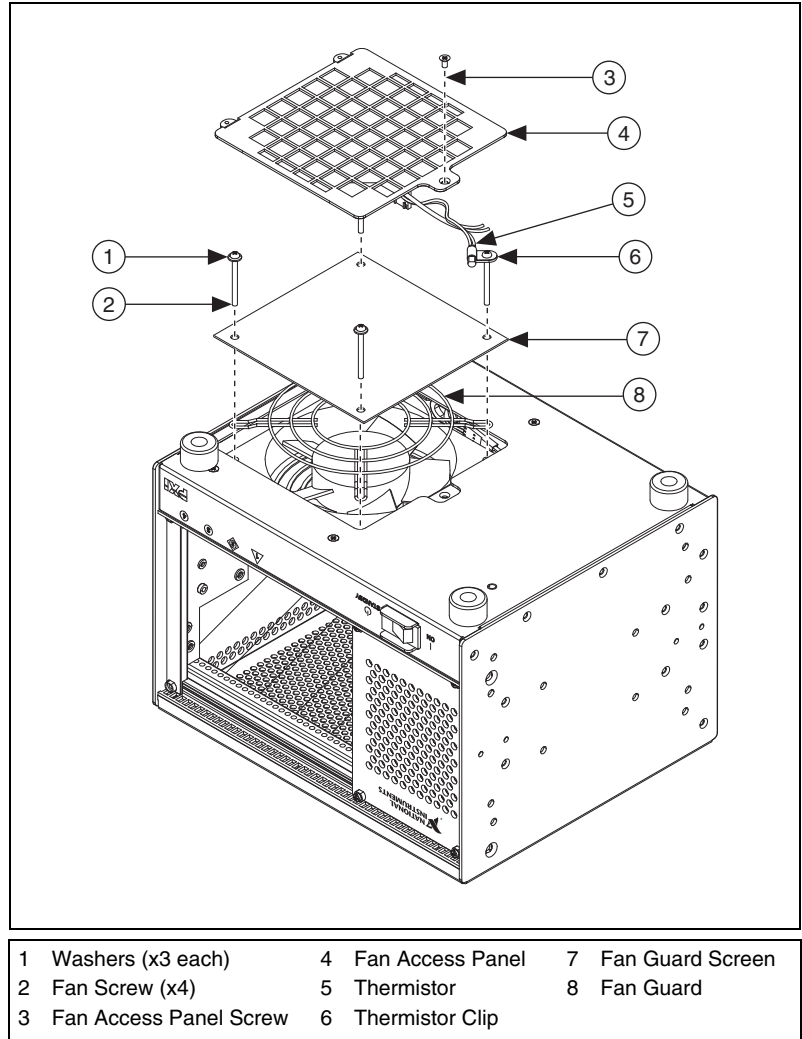

**Figure 5.** PXI and PXI Express Chassis Part Locations (Chassis Shown Upside Down)



Complete the following steps to replace the fan (refer to the previous figure for parts locations):

1. Locate the fan access panel on the bottom of the chassis. Remove the access panel screw and the access panel.
2. Remove the four fan screws, shown in Figure 5, that fasten the fan. Be careful not to lose the screws or washers. (If you lose a screw, replace it with an M3 × 0.5 × 35 mm pan head Phillips screw.)
3. Remove the thermistor and fan guards.
4. Remove the fan.
5. Disconnect the fan cable from the inline connector protruding through the grommet in the fan bracket. The connector is shown in Figure 6.



**Caution** Do *not* allow the wires to fall through the grommet.

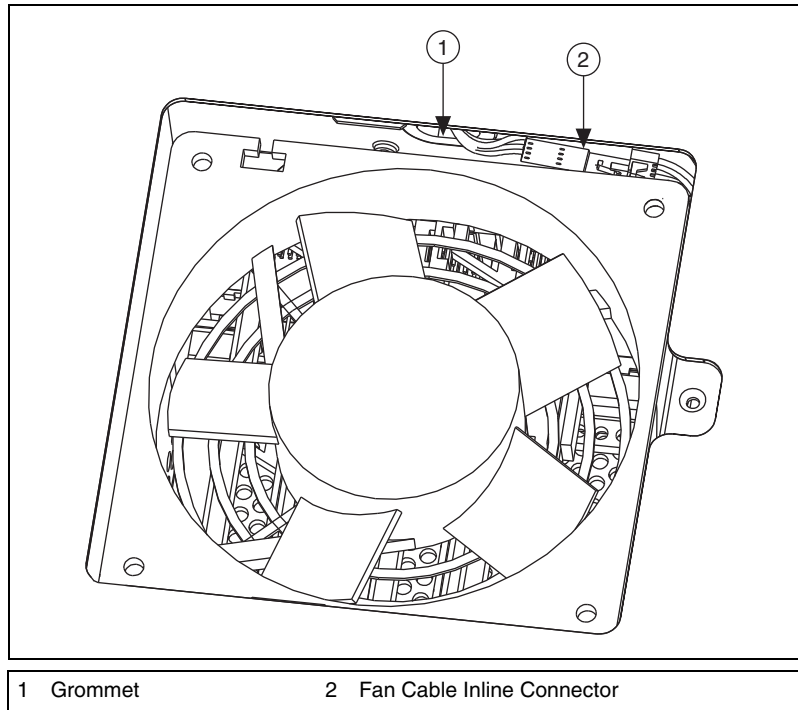

**Figure 6.** Fan Cable Inline Connector

6. Connect the new fan to the inline connector. Place the fan inside the fan bracket with the square slot oriented as shown in Figure 7. The fan flow direction is into the chassis, so the plastic grill on the fan should face toward the PXI card cage.

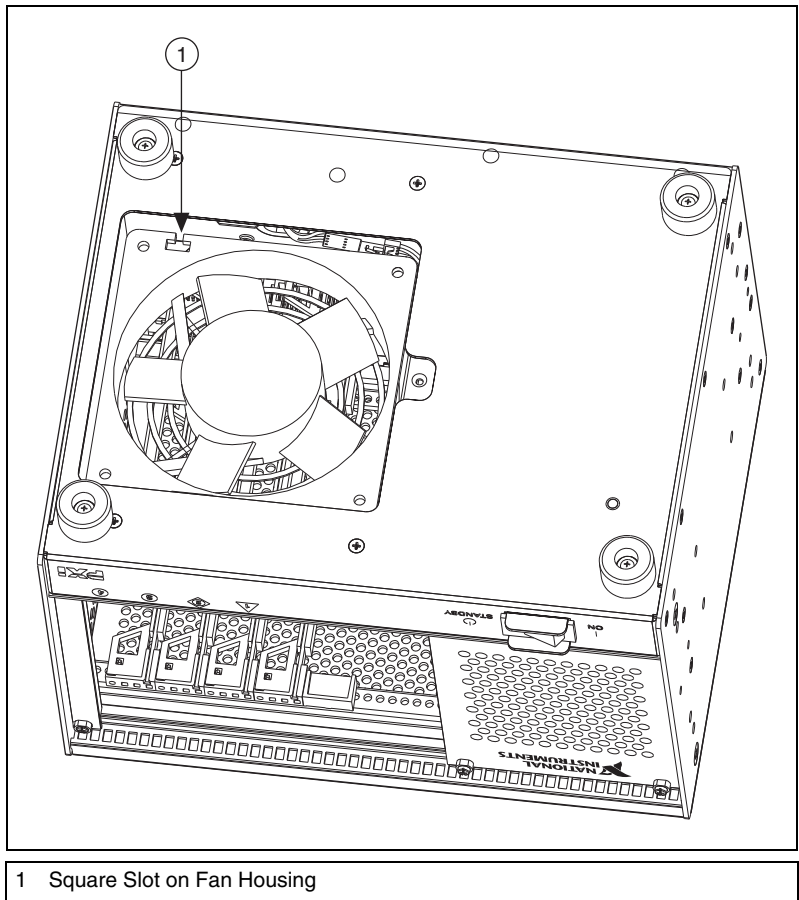

**Figure 7.** Square Slot on Fan Housing

7. Place the fan guards on top of the fan with the round wire guard closest to the fan and the screen guard on top of the round wire guard.

8. Insert three of the four screws with the flat washers closest to the fan and the split spring washers closest to the screw heads. The fourth screw does not use washers, but instead anchors the thermistor. Insert the fourth screw through the thermistor clip hole and orient the thermistor as shown in Figure 8.

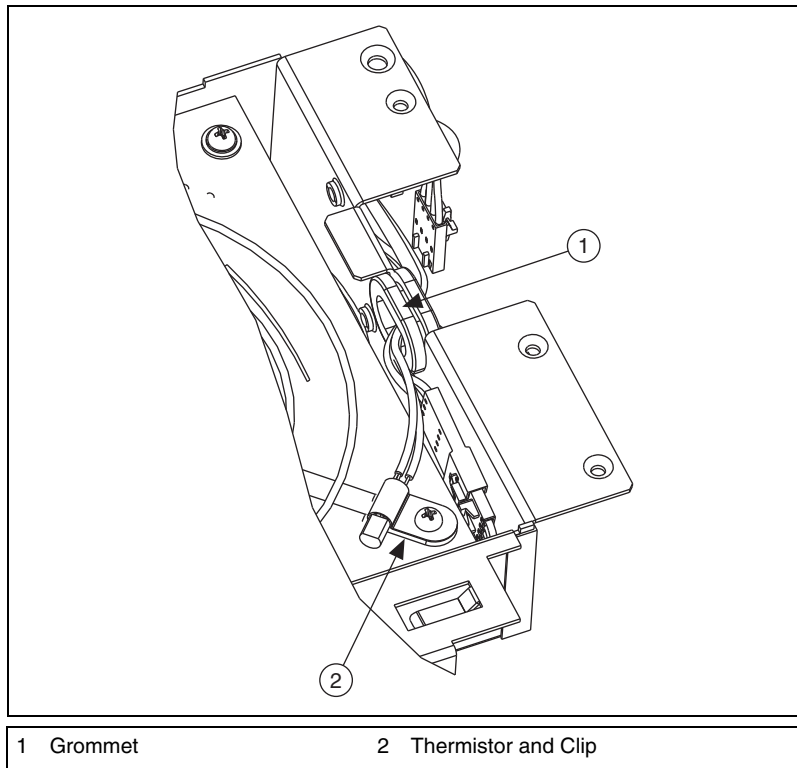

**Figure 8.** Thermistor Location and Orientation

9. Tighten the screws to between 5.7 lb · in. minimum torque and 6.7 lb · in. maximum torque.
10. Place the fan access panel over the opening. Insert and tighten the access panel screw to between 3.0 lb · in. minimum torque and 3.6 lb · in. maximum torque.



**Caution** Reorient the chassis to an upright position and ensure there are no loose parts prior to plugging in the power cord.

LabVIEW, National Instruments, NI, ni.com, the National Instruments corporate logo, and the Eagle logo are trademarks of National Instruments Corporation. Refer to the *Trademark Information* at [ni.com/trademarks](http://ni.com/trademarks) for other National Instruments trademarks. Other product and company names mentioned herein are trademarks or trade names of their respective companies. For patents covering National Instruments products/technology, refer to the appropriate location: **Help»Patents** in your software, the `patents.txt` file on your media, or the *National Instruments Patent Notice* at [ni.com/patents](http://ni.com/patents). Refer to the *Export Compliance Information* at [ni.com/legal/export-compliance](http://ni.com/legal/export-compliance) for the National Instruments global trade compliance policy and how to obtain relevant HTS codes, ECCNs, and other import/export data.