

## COMPREHENSIVE SERVICES

We offer competitive repair and calibration services, as well as easily accessible documentation and free downloadable resources.

## SELL YOUR SURPLUS

We buy new, used, decommissioned, and surplus parts from every NI series. We work out the best solution to suit your individual needs.

 Sell For Cash    Get Credit    Receive a Trade-In Deal

## OBSOLETE NI HARDWARE IN STOCK & READY TO SHIP

We stock **New**, **New Surplus**, **Refurbished**, and **Reconditioned** NI Hardware.



*Bridging the gap between the manufacturer and your legacy test system.*

 1-800-915-6216

 [www.apexwaves.com](http://www.apexwaves.com)

 [sales@apexwaves.com](mailto:sales@apexwaves.com)

*All trademarks, brands, and brand names are the property of their respective owners.*

**Request a Quote**

 **CLICK HERE**

**PXI-1428**

# ***IMAQ™***

---

## **IMAQ PCI/PXI-1428 User Manual**

*High-Quality Camera Link Image Acquisition Device  
for PCI and PXI*

## **Worldwide Technical Support and Product Information**

ni.com

### **National Instruments Corporate Headquarters**

11500 North Mopac Expressway Austin, Texas 78759-3504 USA Tel: 512 683 0100

### **Worldwide Offices**

Australia 1800 300 800, Austria 43 0 662 45 79 90 0, Belgium 32 0 2 757 00 20, Brazil 55 11 3262 3599,  
Canada (Calgary) 403 274 9391, Canada (Ottawa) 613 233 5949, Canada (Québec) 450 510 3055,  
Canada (Toronto) 905 785 0085, Canada (Vancouver) 514 685 7530, China 86 21 6555 7838,  
Czech Republic 420 224 235 774, Denmark 45 45 76 26 00, Finland 385 0 9 725 725 11,  
France 33 0 1 48 14 24 24, Germany 49 0 89 741 31 30, Greece 30 2 10 42 96 427, India 91 80 51190000,  
Israel 972 0 3 6393737, Italy 39 02 413091, Japan 81 3 5472 2970, Korea 82 02 3451 3400,  
Malaysia 603 9131 0918, Mexico 001 800 010 0793, Netherlands 31 0 348 433 466,  
New Zealand 0800 553 322, Norway 47 0 66 90 76 60, Poland 48 22 3390150, Portugal 351 210 311 210,  
Russia 7 095 783 68 51, Singapore 65 6226 5886, Slovenia 386 3 425 4200, South Africa 27 0 11 805 8197,  
Spain 34 91 640 0085, Sweden 46 0 8 587 895 00, Switzerland 41 56 200 51 51, Taiwan 886 2 2528 7227,  
Thailand 662 992 7519, United Kingdom 44 0 1635 523545

For further support information, refer to the *Technical Support and Professional Services* appendix. To comment on the documentation, send email to [techpubs@ni.com](mailto:techpubs@ni.com).

# Important Information

---

## Warranty

The IMAQ PCI/PXI-1428 is warranted against defects in materials and workmanship for a period of one year from the date of shipment, as evidenced by receipts or other documentation. National Instruments will, at its option, repair or replace equipment that proves to be defective during the warranty period. This warranty includes parts and labor.

The media on which you receive National Instruments software are warranted not to fail to execute programming instructions, due to defects in materials and workmanship, for a period of 90 days from date of shipment, as evidenced by receipts or other documentation. National Instruments will, at its option, repair or replace software media that do not execute programming instructions if National Instruments receives notice of such defects during the warranty period. National Instruments does not warrant that the operation of the software shall be uninterrupted or error free.

A Return Material Authorization (RMA) number must be obtained from the factory and clearly marked on the outside of the package before any equipment will be accepted for warranty work. National Instruments will pay the shipping costs of returning to the owner parts which are covered by warranty.

National Instruments believes that the information in this document is accurate. The document has been carefully reviewed for technical accuracy. In the event that technical or typographical errors exist, National Instruments reserves the right to make changes to subsequent editions of this document without prior notice to holders of this edition. The reader should consult National Instruments if errors are suspected. In no event shall National Instruments be liable for any damages arising out of or related to this document or the information contained in it.

EXCEPT AS SPECIFIED HEREIN, NATIONAL INSTRUMENTS MAKES NO WARRANTIES, EXPRESS OR IMPLIED, AND SPECIFICALLY DISCLAIMS ANY WARRANTY OF MERCHANTABILITY OR FITNESS FOR A PARTICULAR PURPOSE. CUSTOMER'S RIGHT TO RECOVER DAMAGES CAUSED BY FAULT OR NEGLIGENCE ON THE PART OF NATIONAL INSTRUMENTS SHALL BE LIMITED TO THE AMOUNT THEREOF PAID BY THE CUSTOMER. NATIONAL INSTRUMENTS WILL NOT BE LIABLE FOR DAMAGES RESULTING FROM LOSS OF DATA, PROFITS, USE OF PRODUCTS, OR INCIDENTAL OR CONSEQUENTIAL DAMAGES, EVEN IF ADVISED OF THE POSSIBILITY THEREOF. This limitation of the liability of National Instruments will apply regardless of the form of action, whether in contract or tort, including negligence. Any action against National Instruments must be brought within one year after the cause of action accrues. National Instruments shall not be liable for any delay in performance due to causes beyond its reasonable control. The warranty provided herein does not cover damages, defects, malfunctions, or service failures caused by owner's failure to follow the National Instruments installation, operation, or maintenance instructions; owner's modification of the product; owner's abuse, misuse, or negligent acts; and power failure or surges, fire, flood, accident, actions of third parties, or other events outside reasonable control.

## Copyright

Under the copyright laws, this publication may not be reproduced or transmitted in any form, electronic or mechanical, including photocopying, recording, storing in an information retrieval system, or translating, in whole or in part, without the prior written consent of National Instruments Corporation.

## Trademarks

CVI™, IMAQ™, LabVIEW™, Measurement Studio™, MITE™, National Instruments™, NI™, ni.com™, NI-DAQ™, NI-IMAQ™, and RTSI™ are trademarks of National Instruments Corporation.

Product and company names mentioned herein are trademarks or trade names of their respective companies.

## Patents

For patents covering National Instruments products, refer to the appropriate location: **Help»Patents** in your software, the `patents.txt` file on your CD, or [ni.com/patents](http://ni.com/patents).

## WARNING REGARDING USE OF NATIONAL INSTRUMENTS PRODUCTS

(1) NATIONAL INSTRUMENTS PRODUCTS ARE NOT DESIGNED WITH COMPONENTS AND TESTING FOR A LEVEL OF RELIABILITY SUITABLE FOR USE IN OR IN CONNECTION WITH SURGICAL IMPLANTS OR AS CRITICAL COMPONENTS IN ANY LIFE SUPPORT SYSTEMS WHOSE FAILURE TO PERFORM CAN REASONABLY BE EXPECTED TO CAUSE SIGNIFICANT INJURY TO A HUMAN.

(2) IN ANY APPLICATION, INCLUDING THE ABOVE, RELIABILITY OF OPERATION OF THE SOFTWARE PRODUCTS CAN BE IMPAIRED BY ADVERSE FACTORS, INCLUDING BUT NOT LIMITED TO FLUCTUATIONS IN ELECTRICAL POWER SUPPLY, COMPUTER HARDWARE MALFUNCTIONS, COMPUTER OPERATING SYSTEM SOFTWARE FITNESS, FITNESS OF COMPILERS AND DEVELOPMENT SOFTWARE USED TO DEVELOP AN APPLICATION, INSTALLATION ERRORS, SOFTWARE AND HARDWARE COMPATIBILITY PROBLEMS, MALFUNCTIONS OR FAILURES OF ELECTRONIC MONITORING OR CONTROL DEVICES, TRANSIENT FAILURES OF ELECTRONIC SYSTEMS (HARDWARE AND/OR SOFTWARE), UNANTICIPATED USES OR MISUSES, OR ERRORS ON THE PART OF THE USER OR APPLICATIONS DESIGNER (ADVERSE FACTORS SUCH AS THESE ARE HEREAFTER COLLECTIVELY TERMED "SYSTEM FAILURES"). ANY APPLICATION WHERE A SYSTEM FAILURE WOULD CREATE A RISK OF HARM TO PROPERTY OR PERSONS (INCLUDING THE RISK OF BODILY INJURY AND DEATH) SHOULD NOT BE RELIANT SOLELY UPON ONE FORM OF ELECTRONIC SYSTEM DUE TO THE RISK OF SYSTEM FAILURE. TO AVOID DAMAGE, INJURY, OR DEATH, THE USER OR APPLICATION DESIGNER MUST TAKE REASONABLY PRUDENT STEPS TO PROTECT AGAINST SYSTEM FAILURES, INCLUDING BUT NOT LIMITED TO BACK-UP OR SHUT-DOWN MECHANISMS. BECAUSE EACH END-USER SYSTEM IS CUSTOMIZED AND DIFFERS FROM NATIONAL INSTRUMENTS' TESTING PLATFORMS AND BECAUSE A USER OR APPLICATION DESIGNER MAY USE NATIONAL INSTRUMENTS PRODUCTS IN COMBINATION WITH OTHER PRODUCTS IN A MANNER NOT EVALUATED OR CONTEMPLATED BY NATIONAL INSTRUMENTS, THE USER OR APPLICATION DESIGNER IS ULTIMATELY RESPONSIBLE FOR VERIFYING AND VALIDATING THE SUITABILITY OF NATIONAL INSTRUMENTS PRODUCTS WHENEVER NATIONAL INSTRUMENTS PRODUCTS ARE INCORPORATED IN A SYSTEM OR APPLICATION, INCLUDING, WITHOUT LIMITATION, THE APPROPRIATE DESIGN, PROCESS AND SAFETY LEVEL OF SUCH SYSTEM OR APPLICATION.

# Compliance

---

## Compliance with FCC/Canada Radio Frequency Interference Regulations

### Determining FCC Class

The Federal Communications Commission (FCC) has rules to protect wireless communications from interference. The FCC places digital electronics into two classes. These classes are known as Class A (for use in industrial-commercial locations only) or Class B (for use in residential or commercial locations). All National Instruments (NI) products are FCC Class A products.

Depending on where it is operated, this Class A product could be subject to restrictions in the FCC rules. (In Canada, the Department of Communications (DOC), of Industry Canada, regulates wireless interference in much the same way.) Digital electronics emit weak signals during normal operation that can affect radio, television, or other wireless products.

All Class A products display a simple warning statement of one paragraph in length regarding interference and undesired operation. The FCC rules have restrictions regarding the locations where FCC Class A products can be operated.

Consult the FCC Web site at [www.fcc.gov](http://www.fcc.gov) for more information.

### FCC/DOC Warnings

This equipment generates and uses radio frequency energy and, if not installed and used in strict accordance with the instructions in this manual and the CE marking Declaration of Conformity\*, may cause interference to radio and television reception. Classification requirements are the same for the Federal Communications Commission (FCC) and the Canadian Department of Communications (DOC).

Changes or modifications not expressly approved by NI could void the user's authority to operate the equipment under the FCC Rules.

### Class A

#### Federal Communications Commission

This equipment has been tested and found to comply with the limits for a Class A digital device, pursuant to part 15 of the FCC Rules. These limits are designed to provide reasonable protection against harmful interference when the equipment is operated in a commercial environment. This equipment generates, uses, and can radiate radio frequency energy and, if not installed and used in accordance with the instruction manual, may cause harmful interference to radio communications. Operation of this equipment in a residential area is likely to cause harmful interference in which case the user is required to correct the interference at their own expense.

#### Canadian Department of Communications

This Class A digital apparatus meets all requirements of the Canadian Interference-Causing Equipment Regulations.

Cet appareil numérique de la classe A respecte toutes les exigences du Règlement sur le matériel brouilleur du Canada.

### Compliance with EU Directives



Users in the European Union (EU) should refer to the Declaration of Conformity (DoC) for information\* pertaining to the CE marking. Refer to the Declaration of Conformity (DoC) for this product for any additional regulatory compliance information. To obtain the DoC for this product, visit [ni.com/hardref.nsf](http://ni.com/hardref.nsf), search by model number or product line, and click the appropriate link in the Certification column.

\* The CE marking Declaration of Conformity contains important supplementary information and instructions for the user or installer.

# Conventions

---

The following conventions are used in this manual:

- <> Angle brackets that contain numbers separated by an ellipsis represent a range of values associated with a bit or signal name—for example, DIO<3..0>.
- » The » symbol leads you through nested menu items and dialog box options to a final action. The sequence **File»Page Setup»Options** directs you to pull down the **File** menu, select the **Page Setup** item, and select **Options** from the last dialog box.
- ◆ The ◆ symbol indicates that the following text applies only to a specific product, a specific operating system, or a specific software version.
-  This icon denotes a note, which alerts you to important information.
-  This icon denotes a caution, which advises you of precautions to take to avoid injury, data loss, or a system crash.
- bold** Bold text denotes items that you must select or click in the software, such as menu items and dialog box options. Bold text also denotes parameter names.
- italic* Italic text denotes variables, emphasis, a cross reference, or an introduction to a key concept. This font also denotes text that is a placeholder for a word or value that you must supply.
- monospace Text in this font denotes text or characters that you should enter from the keyboard, sections of code, programming examples, and syntax examples. This font is also used for the proper names of disk drives, paths, directories, programs, subprograms, subroutines, device names, functions, operations, variables, filenames, and extensions.

# Contents

---

## Chapter 1

### Introduction

About the IMAQ 1428 .....	1-1
Camera Link .....	1-2
Overview .....	1-2
Software Overview .....	1-3
NI-IMAQ Driver Software .....	1-3
National Instruments Application Software .....	1-4
Vision Builder for Automated Inspection .....	1-4
Vision Development Module .....	1-4
Integration with DAQ .....	1-5
Vision and Motion .....	1-5

## Chapter 2

### Installation

What You Need to Get Started .....	2-1
Optional Equipment .....	2-2
Unpacking .....	2-2
Safety Information .....	2-3
Installation .....	2-5
Configuring the IMAQ 1428 .....	2-6
Interfacing with the IMAQ 1428 .....	2-7

## Chapter 3

### Hardware Overview

Functional Overview .....	3-1
Camera Link and IMAQ 1428 .....	3-2
Base Configuration .....	3-2
Medium Configuration .....	3-2
Data Transmission .....	3-2
LUTs .....	3-3
Multiple-Tap Data Formatter .....	3-3
SDRAM .....	3-3
Trigger Control and Mapping Circuitry .....	3-3
High-Speed Timing .....	3-4
Acquisition and Region of Interest (ROI) .....	3-4
Scatter-Gather DMA Controllers .....	3-4
Bus Master PCI Interface .....	3-4

Start Conditions.....	3-5
Acquisition Window Control .....	3-5
Serial Interface .....	3-5

## **Chapter 4**

### **Signal Connections**

Connectors .....	4-1
MDR 26-Pin Connector .....	4-2
68-Pin VHDCI Connector.....	4-2
Connector Signal Connection Descriptions .....	4-4

## **Appendix A**

### **Specifications**

## **Appendix B**

### **Cabling**

## **Appendix C**

### **Technical Support and Professional Services**

## **Glossary**

## **Index**



---

# Introduction

This chapter provides an overview of the IMAQ PCI/PXI-1428 image acquisition device, the Camera Link standard, Camera Link and IMAQ 1428 interfacing guidelines, and your software programming choices.

---

## About the IMAQ 1428

---

The IMAQ 1428 is a highly flexible image acquisition (IMAQ) device that supports a diverse range of Camera Link-compatible cameras from various camera companies. The IMAQ 1428 acquires digital images in real time and stores the images in onboard frame memory or transfers them directly to system memory. Featuring a high-speed data flow path, the IMAQ 1428 is ideal for both industrial and scientific environments.

The IMAQ 1428 is easy to install and configure. It ships with NI-IMAQ, the National Instruments complete IMAQ driver software you can use to directly control the IMAQ 1428 and other National Instruments IMAQ hardware products. With NI-IMAQ, you can quickly and easily start your applications without having to program the device at the register level.

The IMAQ 1428 supports the Camera Link Base configuration. The VHDCI 68-pin connector provides access to the 8-bit  $\times$  4 mode of the Camera Link Medium configuration. For further configuration information, refer to the [Camera Link and IMAQ 1428](#) section of Chapter 3, [Hardware Overview](#).

The VHDCI 68-pin connector has four external input/output (I/O) lines you can use as triggers or as high-speed digital I/O lines.

For more advanced digital or analog system triggering or digital I/O lines, you can use the IMAQ 1428 and NI-IMAQ with the National Instruments data acquisition (DAQ) or motion control product lines.

Synchronizing several functions to a common trigger or timing event can be a challenge with image acquisition devices. The IMAQ 1428 uses the Real-Time System Integration (RTSI) bus to solve this problem.

The RTSI bus uses the National Instruments RTSI bus interface and ribbon cable to route additional timing and trigger signals between the PCI-1428 and up to four National Instruments DAQ, motion control, or IMAQ devices. The RTSI bus can also synchronize multiple IMAQ hardware captures. The RTSI bus is integrated into the PXI system's backplane for the PXI-1428.

For detailed specifications of the IMAQ 1428, refer to Appendix A, [Specifications](#).

## Camera Link

---

This section provides a brief overview of the Camera Link standard. For more detailed information about Camera Link specifications, refer to the *Specifications of the Camera Link Interface Standard for Digital Cameras and Frame Grabbers* manual. This manual is available on several Web sites, including the Automated Imaging Association site at [www.machinevisiononline.org](http://www.machinevisiononline.org).

### Overview

Developed by a consortium of camera and image acquisition device manufacturers, Camera Link is a standard for interfacing digital cameras with image acquisition devices. Camera Link simplifies connectivity between the image acquisition device and the camera by defining a single standard connector for both. This standard ensures physical compatibility of devices bearing the Camera Link logo.

The basis for the Camera Link standard is the National Semiconductor Channel Link chipset, a data transmission method consisting of a general-purpose transmitter/receiver pair. The Channel Link driver takes 28 bits of parallel digital data and a clock and serializes the stream to four LVDS (EIA-644) data streams and an LVDS clock, providing high-speed data transmission across 10 wires and over distances of up to 10 m.

# Software Overview

---

Programming the IMAQ 1428 requires the NI-IMAQ driver software for controlling the hardware. National Instruments also offers the following application software packages for analyzing and processing your acquired images.

- **Vision Builder for Automated Inspection (AI)**—Allows you to configure solutions to common inspection tasks.
- **National Instruments Vision Development Module**—Provides customized control over hardware and algorithms.

The following sections provide an overview of the driver software and the application software. For detailed information about individual software packages, refer to the documentation specific to each package.

## NI-IMAQ Driver Software

The NI-IMAQ driver software ships with the IMAQ 1428. NI-IMAQ has an extensive library of functions—such as routines for video configuration, continuous and single shot image acquisition, memory buffer allocation, trigger control, and device configuration—you can call from the application development environment (ADE). NI-IMAQ handles many of the complex issues between the computer and the IMAQ device, such as programming interrupts and camera control.

NI-IMAQ performs all functions required for acquiring and saving images but does not perform image analysis. For image analysis functionality, refer to the *National Instruments Application Software* section.

NI-IMAQ is also the interface path between the IMAQ 1428 and LabVIEW, LabWindows™/CVI™, or a text-based programming environment. The NI-IMAQ software kit includes a series of libraries for image acquisition for LabVIEW, LabWindows/CVI, and Measurement Studio, which contains libraries for Microsoft Visual Basic.

NI-IMAQ features both high-level and low-level functions. Examples of high-level functions include the sequences to acquire images in multi-buffer, single-shot, or continuous mode. An example of a low-level function is configuring an image sequence, since it requires advanced understanding of the IMAQ device and image acquisition.

## National Instruments Application Software

This section describes the National Instruments application software packages you can use to analyze and process the images you acquire with the IMAQ 1428.

### Vision Builder for Automated Inspection

NI Vision Builder for Automated Inspection (AI) is configurable machine vision software that you can use to prototype, benchmark, and deploy applications. Vision Builder AI does not require programming, but is scalable to powerful programming environments.

Vision Builder AI allows you to easily configure and benchmark a sequence of visual inspection steps, as well as deploy the visual inspection system for automated inspection. With Vision Builder AI, you can perform powerful visual inspection tasks and make decisions based on the results of individual tasks. You also can migrate the configured inspection to LabVIEW, extending the capabilities of the applications if necessary.

Vision Builder AI is available for LabVIEW, LabWindows/CVI, and Measurement Studio, which includes support for Microsoft Visual Basic.

### Vision Development Module

The Vision Development Module is an image acquisition, processing, and analysis library of more than 270 functions for the following common machine vision tasks:

- Pattern matching
- Particle analysis
- Gauging
- Taking measurements
- Grayscale, color, and binary image display

You can use the Vision Development Module functions individually or in combination. With the Vision Development Module, you can acquire, display, and store images, as well as perform image analysis and processing. Using the Vision Development Module, imaging novices and experts can program the most basic or complicated image applications without knowledge of particular algorithm implementations.

NI Vision Assistant is included with the Vision Development Module. Vision Assistant is an interactive prototyping tool for machine vision and scientific imaging developers. With Vision Assistant, you can prototype vision applications quickly and test how various vision image processing functions work.

Vision Assistant generates a Builder file, which is a text description containing a recipe of the machine vision and image processing functions. This Builder file provides a guide you can use for developing applications in any ADE, such as LabWindows/CVI or Visual Basic, using the Vision Assistant machine vision and image processing libraries. Using the LabVIEW VI creation wizard, Vision Assistant can create LabVIEW VI diagrams that perform the prototype you created in Vision Assistant. You can then use LabVIEW to add functionality to the generated VI.

## Integration with DAQ

Platforms that support NI-IMAQ also support NI-DAQ and a variety of National Instruments DAQ boards. This allows integration between IMAQ devices and National Instruments DAQ products.

## Vision and Motion

Use National Instruments high-performance stepper and servo motion control products with pattern matching software in inspection and guidance applications, such as locating alignment markers on semiconductor wafers, guiding robotic arms, inspecting the quality of manufactured parts, and locating cells.

---

# Installation

This chapter contains a list of necessary and optional items for getting started acquiring images with the IMAQ PCI/PXI-1428. This chapter also explains how to unpack, configure, and install the IMAQ 1428.

## What You Need to Get Started

---

You need the following items to set up and use the IMAQ 1428:

- Getting Started with Your IMAQ System*
- NI-IMAQ for Windows 2000/NT/XP and documentation
- Pentium-based PCI computer running Windows 2000/NT/XP
- Camera Link camera
- MDR 26-pin Camera Link cable
- Optional software packages and documentation:
  - IMAQ Vision for LabVIEW, LabWindows/CVI, or Measurement Studio (Visual Basic)
  - IMAQ Vision Builder
  - LabVIEW
  - LabWindows/CVI
  - Measurement Studio

## Optional Equipment

---

National Instruments offers a variety of products for use with the IMAQ 1428, including the following:

- IMAQ D6804 breakout cable used for external triggering only. This cable provides BNC connectivity to the four external trigger lines on the 68-pin VHDCI connector.
- IMAQ D6826 breakout cable used for medium configuration and external triggering. This cable breaks the VHDCI connector into a 25-pin D-SUB for triggering and an MDR 26-pin Camera Link cable for medium configuration connectivity.
- RTSI bus cables for connecting the PCI-1428 to other IMAQ, motion control, or DAQ devices.
- Other National Instruments DAQ devices for enhanced triggering, timing, or input/output.

For more specific information about these products, refer to the National Instruments catalog, visit [ni.com](http://ni.com), or call the National Instruments office nearest you.

## Unpacking

---

The IMAQ 1428 ships in an antistatic package to prevent electrostatic discharge from damaging device components. To avoid such damage in handling the device, take the following precautions:

- Ground yourself using a grounding strap or by holding a grounded object, such as the computer chassis.
- Touch the antistatic package to a metal part of the computer chassis before removing the device from the package.



**Caution** *Never* touch the exposed pins of connectors.

Remove the device from the package and inspect it for loose components or any other signs of damage. Notify National Instruments if the device appears damaged in any way. Do *not* install a damaged device in the computer.

Store the IMAQ 1428 in the antistatic envelope when not in use.

# Safety Information

---



**Caution** The following paragraphs contain important safety information you *must* follow when installing and operating the device.

Do *not* operate the device in a manner not specified in the documentation. Misuse of the device may result in a hazard and may compromise the safety protection built into the device. If the device is damaged, turn it off and do *not* use it until service-trained personnel can check its safety. If necessary, return the device to National Instruments for repair.

Keep away from live circuits. Do *not* remove equipment covers or shields unless you are trained to do so. If signal wires are connected to the device, hazardous voltages can exist even when the equipment is turned off. To avoid a shock hazard, do *not* perform procedures involving cover or shield removal unless you are qualified to do so. Disconnect all field power prior to removing covers or shields.

If the device is rated for use with hazardous voltages ( $>30 V_{\text{rms}}$ ,  $42.4 V_{\text{pk}}$ , or  $60 V_{\text{dc}}$ ), it may require a safety earth-ground connection wire. Refer to the device specifications for maximum voltage ratings.

Because of the danger of introducing additional hazards, do *not* install unauthorized parts or modify the device. Use the device only with the chassis, modules, accessories, and cables specified in the installation instructions. All covers and filler panels *must* be installed while operating the device.

Do *not* operate the device in an explosive atmosphere or where flammable gases or fumes may be present. Operate the device only at or below the pollution degree stated in the specifications. Pollution consists of any foreign matter—solid, liquid, or gas—that may reduce dielectric strength or surface resistivity. The following is a description of pollution degrees.

- Pollution Degree 1—No pollution or only dry, nonconductive pollution occurs. The pollution has no effect.
- Pollution Degree 2—Normally only nonconductive pollution occurs. Occasionally, nonconductive pollution becomes conductive because of condensation.
- Pollution Degree 3—Conductive pollution or dry, nonconductive pollution occurs. Nonconductive pollution becomes conductive because of condensation.



Clean the device and accessories by brushing off light dust with a soft, nonmetallic brush. Remove other contaminants with a stiff, nonmetallic brush. The unit *must* be completely dry and free from contaminants before returning it to service.

You *must* insulate signal connections for the maximum voltage for which the device is rated. Do *not* exceed the maximum ratings for the device. Remove power from signal lines before connection to or disconnection from the device.



**Caution** National Instruments measurement products may be classified as either Installation Category I or II. Operate products at or below the Installation Category level specified in the hardware specifications.

**Installation Category<sup>1</sup>:** Measurement circuits are subjected to working voltages<sup>2</sup> and transient stresses (overvoltage) from the circuit to which they are connected during measurement or test. Installation Category establishes standardized impulse withstand voltage levels that commonly occur in electrical distribution systems. The following is a description of Installation (Measurement<sup>3</sup>) Categories:

- Installation Category I is for measurements performed on circuits *not* directly connected to the electrical distribution system referred to as MAINS<sup>4</sup> voltage. This category is for measurements of voltages from specially protected secondary circuits. Such voltage measurements include signal levels, special equipment, limited-energy parts of equipment, circuits powered by regulated low-voltage sources, and electronics.
- Installation Category II is for measurements performed on circuits directly connected to the electrical distribution system. This category refers to local-level electrical distribution, such as that provided by a standard wall outlet (for example, 115 V for U.S. or 230 V for Europe). Examples of Installation Category II are measurements performed on household appliances, portable tools, and similar products.

---

<sup>1</sup> Installation Categories as defined in electrical safety standard IEC 61010-1.

<sup>2</sup> Working voltage is the highest rms value of an AC or DC voltage that can occur across any particular insulation.

<sup>3</sup> Installation Category is also referred to as Measurement Category.

<sup>4</sup> MAINS is defined as the (hazardous live) electrical supply system to which equipment is designed to be connected for the purpose of powering the equipment. Suitably rated measuring circuits may be connected to the MAINS for measuring purposes.

- Installation Category III is for measurements performed in the building installation at the distribution level. This category refers to measurements on hard-wired equipment such as equipment in fixed installations, distribution boards, and circuit breakers. Other examples are wiring, including cables, bus-bars, junction boxes, switches, socket-outlets in the fixed installation, and stationary motors with permanent connections to fixed installations.
- Installation Category IV is for measurements performed at the primary electrical supply installation (<1,000 V). Examples include electricity meters and measurements on primary overcurrent protection devices and on ripple control units.

## Installation

---

Install the IMAQ 1428 in any open compatible expansion slot in the PCI or PXI system. Appendix A, *Specifications*, lists the typical power requirements for each device.

The following instructions are for general installation. Consult the computer user manual or technical reference manual for specific instructions and warnings.



**Caution** The IMAQ 1428 is a sensitive electronic device shipped in an antistatic bag. Open only at an approved workstation and observe precautions for handling electrostatic-sensitive devices.



**Note** You must install the NI-IMAQ driver software before installing the IMAQ 1428 device. For information about how to install NI-IMAQ, refer to the *Getting Started with Your IMAQ System* document and the *NI-IMAQ Release Notes*.

- ◆ PCI-1428
  1. Power off and unplug the computer.



**Caution** To protect yourself and the computer from electrical hazards, the computer must remain unplugged until the installation is complete.

2. Remove the cover to expose access to the PCI expansion slots.
3. Choose an unused 5 V PCI slot, and remove the corresponding expansion slot cover on the back panel of the computer.

4. Touch a metal part on the computer case to discharge any static electricity that might be on your clothes or body before handling the PCI-1428. Static electricity can damage the device.
  5. Gently rock the PCI-1428 into the slot. The connection may be tight, but do not force the device into place.
  6. If required, screw the mounting bracket of the device to the back panel rail of the computer.
  7. Replace the cover.
  8. Plug in and power on the computer.
- ◆ PXI-1428
1. Power off and unplug the chassis.



**Caution** To protect yourself and the computer from electrical hazards, the computer must remain unplugged until the installation is complete.

2. Choose an unused 3.3 V or 5 V peripheral slot and remove the filler panel.
3. Touch a metal part on the chassis to discharge any static electricity that might be on your clothes or body. Static electricity can damage the device.
4. Insert the PXI-1428 into the chosen slot. Use the injector/ejector handle to fully inject the device into place.
5. Screw the front panel of the PXI-1428 to the front panel mounting rails of the chassis.
6. Visually verify the installation.
7. Plug in and power on the chassis.

Your IMAQ 1428 is now installed.

## Configuring the IMAQ 1428

---

After you have installed the IMAQ 1428 and powered on your computer, Windows will recognize the device and assign resources to it. Use Measurement & Automation Explorer (MAX) to configure the IMAQ 1428 for acquisition.

# Interfacing with the IMAQ 1428

---

The Camera Link standard defines physical connections between image acquisition devices and Camera Link cameras, and it allows for flexibility of image format and data transfer protocols. The camera manufacturer defines image parameters, such as image resolution and the number of bits per pixel. Camera control parameters, such as frame-on-demand and exposure control signals, are also defined by the camera manufacturer.

These variable parameters are defined on a per-camera basis in a camera file (`camera_model.icd`) supplied by National Instruments. The NI-IMAQ driver software uses the information in this camera file to program the IMAQ 1428 to acquire images from a specific camera. Without this camera file, the driver does not have the information necessary to configure the IMAQ 1428 for acquisition.

MAX, the National Instruments configuration utility, provides a simple interface for associating a camera file with the IMAQ 1428. Use the following guidelines to access the camera file in MAX:

1. Launch MAX, and expand the **Devices and Interfaces** branch of the configuration tree.
2. Expand the **IMAQ 1428** branch.
3. Right-click **Channel 0** and select **Camera**.
4. Select your camera from the menu. If your camera is not in the menu, verify that the camera file is installed in the `NI-IMAQ\Data` directory.

Many camera files are installed when you install NI-IMAQ, and many more are available for download from the National Instruments Camera Advisor at [ni.com/camera](http://ni.com/camera). When installing new camera files, save them to the Data folder located at `Program Files\National Instruments\NI-IMAQ\Data`.

Contact National Instruments technical support to request camera files not available in the Camera Advisor. Refer to Appendix C, *Technical Support and Professional Services*, for information about National Instruments technical support.

# Hardware Overview

This chapter provides an overview of IMAQ PCI/PXI-1428 hardware functionality and explains the operations of the device's functional units.

## Functional Overview

The IMAQ 1428 features a flexible, high-speed data path optimized for receiving and formatting video data from Camera Link cameras.

Figure 3-1 illustrates the key functional components of the IMAQ 1428.

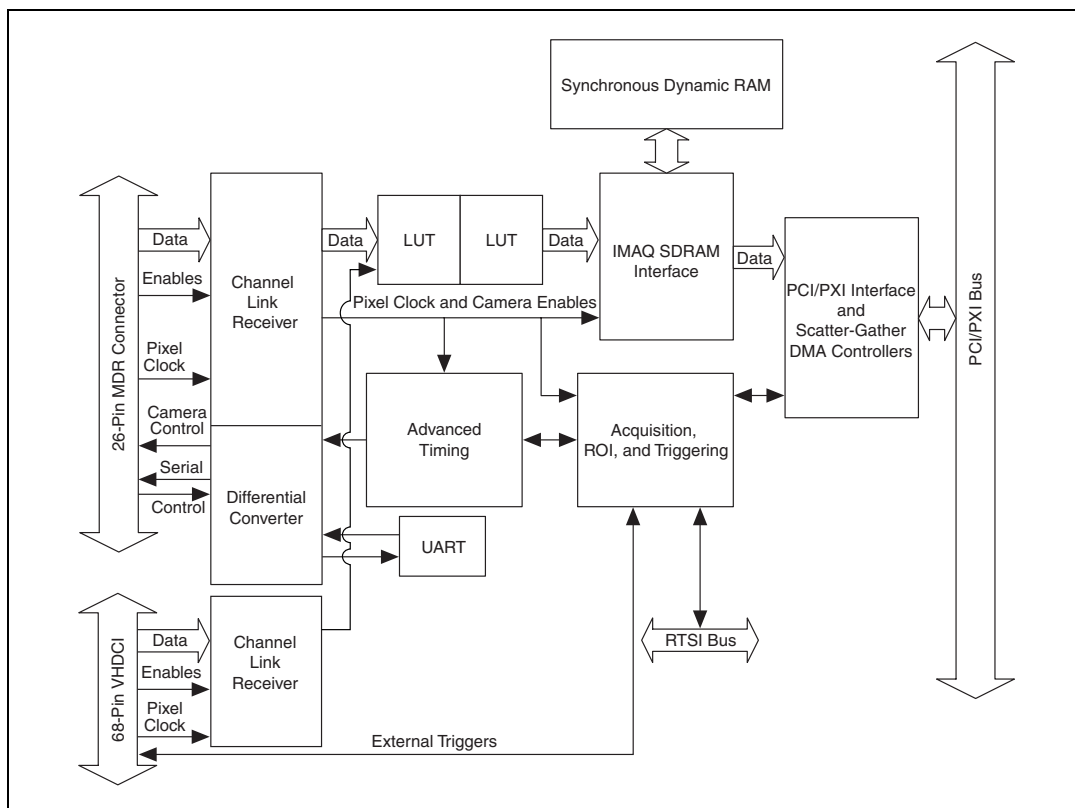

**Figure 3-1.** IMAQ 1428 Block Diagram

## Camera Link and IMAQ 1428

The IMAQ 1428 supports the Camera Link Base configuration as well as the 8-bit  $\times$  4 mode of the Camera Link Medium configuration.

### Base Configuration

The Camera Link Base configuration places 24 data bits and four enable signals (Frame Valid, Line Valid, Data Valid, and a spare) on a single Channel Link part and cable.

The Base configuration includes asynchronous serial transmission as well as four digital camera control lines for controlling exposure time, frame rates, and other camera control signals. These four control lines are configured in the camera file to generate precise timing signals for controlling digital camera acquisition.

Base configuration includes the following bit allocations:

- 8-bit  $\times$  1, 2, and 3 taps (channels)
- 10-bit  $\times$  1 and 2 taps
- 12-bit  $\times$  1 and 2 taps
- 14-bit  $\times$  1 tap
- 16-bit  $\times$  1 tap
- 24-bit RGB

### Medium Configuration

The IMAQ 1428 supports the 8-bit  $\times$  4 tap of the Camera Link Medium configuration. The Medium configuration requires using both connectors. This configuration allows for more data throughput by offering two synchronized data streams between the camera and the IMAQ 1428.

## Data Transmission

A 28-to-4 serializing Channel Link chip drives the data and camera enable signals across the Camera Link cable, and the camera's pixel clock controls the Channel Link's data transmission. The four LVDS pairs are then deserialized by another Channel Link chip on the IMAQ 1428.



**Note** Exact timing of camera and image acquisition device communication is camera dependent. The *Specifications of the Camera Link Interface Standard for Digital Cameras and Frame Grabbers* manual fully explains the Camera Link timing requirements.

## LUTs

The IMAQ 1428 offers lookup tables (LUTs) that can perform operations such as contrast enhancement, data inversion, gamma manipulation, or other nonlinear transfer functions. The LUT fully supports any 8-bit to 16-bit base or medium configuration supported by the IMAQ 1428. Refer to the [Camera Link and IMAQ 1428](#) section for more information on supported Camera Link configurations.

## Multiple-Tap Data Formatter

Many digital cameras transfer multiple taps, or channels, of data simultaneously to increase the frame rate of the camera. However, the data in each tap may not be transferred in the traditional top-left to bottom-right direction. Also, the taps may not transfer data in the same direction.

The multiple-tap data formatting circuitry on the IMAQ 1428 can reorder the data from up to four taps. The data from each tap can be independently scanned either from left-to-right or right-to-left and top-to-bottom or bottom-to-top.



**Note** For your convenience, data reformatting instructions for these cameras have been preprogrammed into the camera files.

## SDRAM

The PXI-1428 has 32 MB of onboard high-speed synchronous dynamic RAM (SDRAM). The PCI-1428 has 16 MB of SDRAM. The IMAQ 1428 uses the onboard RAM as a FIFO buffer to ensure a complete acquisition. Even when the data rate from the camera exceeds PCI throughput, you can acquire without interruption until the onboard RAM is full.

## Trigger Control and Mapping Circuitry

The trigger control and mapping circuitry routes, monitors, and drives the external and RTSI bus trigger lines. You can configure each line to start an acquisition on a rising or falling edge and drive each line asserted or unasserted, much like a digital I/O line. You also can map pulses from the high-speed timing circuitry or many of the IMAQ 1428 status signals to these trigger lines. Four external and four RTSI bus triggers (all of which are programmable for polarity and direction) are available for simultaneous use.

## High-Speed Timing

Built from high-speed counters, the high-speed timing circuitry on the IMAQ 1428 can generate precise real-time control signals for your camera. Map the output of this circuitry to a trigger line to provide accurate pulses and pulse trains. Use these control signals to control exposure time and frame rate.



**Note** For your convenience, the external control for cameras that support the IMAQ 1428 has been preprogrammed into the camera file. You can use MAX to specify the frequency and duration of these signals in easy-to-use units.

## Acquisition and Region of Interest (ROI)

The acquisition and ROI circuitry monitors incoming video signals and routes the active pixels to the multiple-tap data formatter and SDRAM. The IMAQ 1428 can perform ROI on all video lines and frames. In an ROI acquisition, select an area within the acquisition window to transfer across the PCI bus to system memory.



**Note** You can use MAX to set the acquisition and ROI parameters.

## Scatter-Gather DMA Controllers

The IMAQ 1428 uses three independent onboard direct memory access (DMA) controllers. The DMA controllers transfer data between the onboard SDRAM memory buffers and the PCI bus. Each of these controllers supports scatter-gather DMA, which allows the DMA controller to reconfigure on-the-fly. The IMAQ 1428 can perform continuous image transfers directly to either contiguous or fragmented memory buffers.

## Bus Master PCI Interface

The IMAQ 1428 implements the PCI interface with a National Instruments custom application-specific integrated circuit (ASIC), the PCI MITE. The PCI interface can transfer data at a theoretical maximum rate of 133 MB/s in bus master mode.



## Start Conditions

The IMAQ 1428 can start acquisitions in the following ways:

- **Software control**—The IMAQ 1428 supports software control of acquisition start. You can configure the IMAQ 1428 to capture a fixed number of frames. This configuration is useful for capturing a single frame or a sequence of frames.
- **Trigger control**—You can start an acquisition by enabling external or RTSI bus trigger lines. Each of these inputs can start a video acquisition on a rising or falling edge. You can use all four external triggers and up to four RTSI bus triggers simultaneously.
- **Delayed acquisition**—Use either software or triggers to start acquisitions instantaneously or after skipping a specific number of frames. You can use delayed acquisition for post-trigger applications.

## Acquisition Window Control

You can configure the following parameters on the IMAQ 1428 to control the video acquisition window:

- **Acquisition window**—The IMAQ 1428 allows the user to specify a particular region of active pixels and active lines within the incoming video data. The active pixel region selects the starting pixel and number of pixels to be acquired relative to the assertion edge of the horizontal (or line) enable signal from the camera. The active line region selects the starting line and number of lines to be acquired relative to the assertion edge of the vertical (or frame) enable signal.
- **Region of interest**—The IMAQ 1428 uses a second level of active pixel and active line regions for selecting a region of interest. Using the region-of-interest circuitry, the device acquires only a selected subset of the acquisition window.

## Serial Interface

The IMAQ 1428 provides serial connections to and from the camera through two LVDS pairs in the Camera Link cable. All Camera Link serial communication uses one start bit, one stop bit, no parity, and no hardware handshaking.

The IMAQ 1428 supports the following baud rates: 56000, 38400, 19200, 9600, 7200, 4800, 3600, 2400, 2000, 1800, 1200, 600, and 300.

You can use the serial interface interactively with MAX and `clsercon.exe`, or programmatically with LabVIEW and C.

Interactively:

- MAX—Use MAX with a camera file containing preprogrammed commands. When an acquisition is initiated, the commands are sent to the camera.
- `clsercon.exe`—Use National Instruments terminal emulator for Camera Link, `clsercon.exe`, if a camera file with preprogrammed serial commands does not exist for your camera. With `clsercon.exe`, you can still communicate serially with your camera. Go to `<NI-IMAQ>\bin` to access `clsercon.exe`.

Programmatically:

- LabVIEW—Use the serial interface programmatically, through calls to the NI-IMAQ driver using the IMAQ Serial Write and IMAQ Serial Read VIs. Go to `<LabVIEW>\vi.lib\vision\driver\imaq11.lib` to access these files.
- C—Use the serial interface programmatically, through calls to the NI-IMAQ driver using `imgSessionSerialWrite` and `imgSessionSerialRead`.



**Note** `clsercon.exe`, IMAQ Serial Write, IMAQ Serial Read, `imgSessionSerialWrite`, and `imgSessionSerialRead` are used for directly accessing the IMAQ 1428 serial port and are not required for most users.

National Instruments also fully supports the recommended serial API described in the *Specifications of the Camera Link Interface Standard for Digital Cameras and Frame Grabbers* manual.

# Signal Connections

This chapter describes the MDR 26-pin connector and the 68-pin VHDCI connector on the IMAQ 1428 device.

## Connectors

Figure 4-1 shows the connectors on the IMAQ 1428 device.

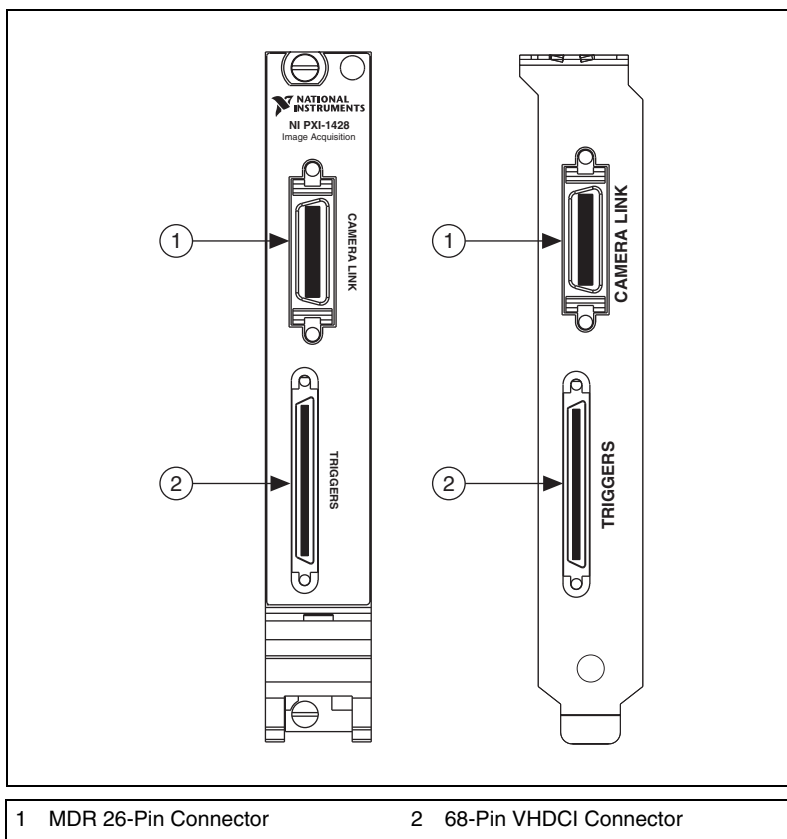
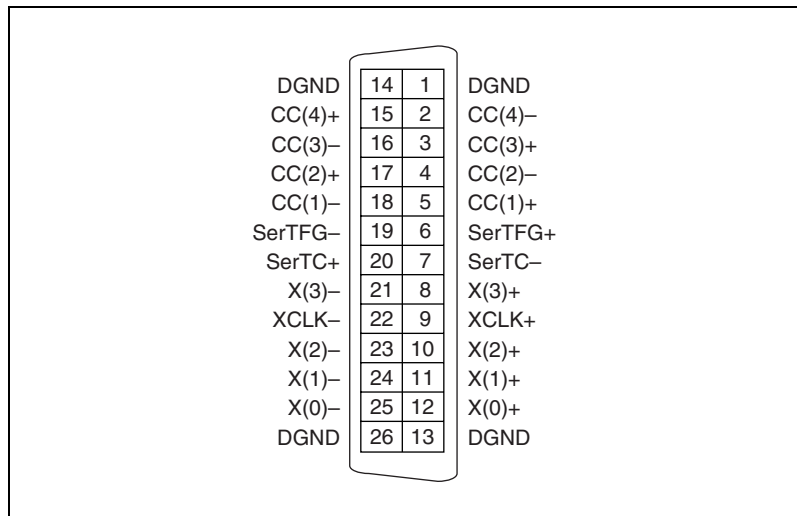

**Figure 4-1.** IMAQ 1428 Connectors

## MDR 26-Pin Connector

The MDR 26-pin connector provides reliable high-frequency transfer rates between the camera and the acquisition device. To access this connector, use a 3M Camera Link cable. For additional information on Camera Link cables, including ordering information and cable lengths, refer to the [Camera Link Cables](#) section of Appendix B, *Cabling*.

Figure 4-2 shows the IMAQ 1428 MDR 26-pin connector assignments. Refer to Table 4-1 for a description of the MDR-26 and 68-pin VHDCI signal connections.



**Figure 4-2.** MDR 26-Pin Connector Assignments

## 68-Pin VHDCI Connector

The 68-pin VHDCI connector connects to external digital I/O lines, triggers, and medium configuration 8-bit  $\times$  4 mode. To access these connections, build a custom cable or use an optional cable from National Instruments. For information about building a custom cable for the 68-pin VHDCI connector, refer to the [68-Pin VHDCI Cable Specifications](#) section of Appendix B, *Cabling*.

Figure 4-3 shows the 68-pin VHDCI connector pinout. Refer to Table 4-1 for a description of the MDR-26 and 68-pin VHDCI signal connections.

RESERVED	68	34	RESERVED
RESERVED	67	33	RESERVED
RESERVED	66	32	RESERVED
RESERVED	65	31	RESERVED
RESERVED	64	30	RESERVED
RESERVED	63	29	RESERVED
RESERVED	62	28	RESERVED
RESERVED	61	27	RESERVED
DGND	60	26	DGND
DGND	59	25	Y (0)-
RESERVED	58	24	Y (0)+
RESERVED	57	23	Y (1)-
RESERVED	56	22	Y (1)+
RESERVED	55	21	Y (2)-
RESERVED	54	20	Y (2)+
RESERVED	53	19	YCLK -
DGND	52	18	YCLK+
DGND	51	17	Y (3)-
RESERVED	50	16	Y (3)+
RESERVED	49	15	RESERVED
RESERVED	48	14	RESERVED
RESERVED	47	13	RESERVED
RESERVED	46	12	RESERVED
RESERVED	45	11	RESERVED
RESERVED	44	10	RESERVED
RESERVED	43	9	RESERVED
DGND	42	8	TTL_TRIG(0)
DGND	41	7	TTL_TRIG(1)
DGND	40	6	TTL_TRIG(2)
DGND	39	5	TTL_TRIG(3)
*CHASSIS_GND	38	4	CHASSIS_GND*
RESERVED	37	3	RESERVED
DGND	36	2	DGND
RESERVED	35	1	RESERVED

\*For PXI-1428, the signal for pin 4 and pin 38 is DGND.

**Figure 4-3.** PCI-1428 68-Pin VHDCI Connector Pin Assignments

## Connector Signal Connection Descriptions

Table 4-1 describes the MDR-26 and 68-pin VHDCI signal connections.

**Table 4-1.** I/O Connector Signals

Signal Name	Description
TTL_TRIG<3..0>	TTL external triggers/DIO lines (input/output)
DGND	A direct connection to digital GND on the IMAQ 1428
CHASSIS_GND	A direct connection to the computer chassis, which is grounded through the power cord
X<3..0>±	LVDS Base configuration data and enable signals from the camera to the acquisition device
Y<3..0>±	LVDS Medium configuration data and enable signals from the camera to the acquisition device
XCLK±	Transmission clock on the Base configuration chip for Camera Link communication between the acquisition device and the camera
YCLK±	Transmission clock on the Medium configuration chip for Camera Link communication between the acquisition device and the camera
SerTC±	Serial transmission to the camera from the image acquisition device
SerTFG±	Serial transmission to the frame grabber from the camera
CC<4..1>±	Four LVDS pairs, defined as camera inputs and acquisition device outputs, reserved for camera control  On some cameras, the camera controls allow the acquisition device to control exposure time and frame rate.

# Specifications

This appendix lists the specifications of the IMAQ 1428. These specifications are typical at 25 °C, unless otherwise stated.

## External Connections

Number of external trigger I/O lines.....	4
Trigger input	
Voltage range .....	0 to 5 V (TTL)
Input high voltage .....	2.0 V
Input low voltage .....	0.8 V
Polarity .....	Programmable, active-high or active-low
Trigger output	
Voltage range .....	0 to 5 V (TTL)
Output high voltage .....	2.4 V at 15 mA source
Output low voltage .....	0.55 V at 10 mA sink
Polarity .....	Programmable, active-high or active-low
Power-on state .....	Input (high-impedance) 10 K $\Omega$ pull-up to 5 V
Pixel clock.....	Camera Link compatible
Enables .....	Camera Link compatible
Control signal.....	Camera Link compatible
Video data .....	Camera Link compatible

## Clocks

Pixel clock frequency range.....20 to 50 MHz



**Note** Camera Link cameras must transmit at a minimum of 20 MHz.<sup>1</sup>

## PCI Interface

Theoretical max PCI bandwidth.....133 MB/s

## Memory

Onboard memory

PCI-1428.....16 MB SDRAM

PXI-1428 .....32 MB SDRAM

LUTs.....Four 8-bit; two 10-bit to 16-bit

## Serial Requirements

Baud rates supported .....300, 600, 1200, 1800, 2000, 2400,  
3600, 4800, 7200, or 9600 bps;  
19.2, 38.4, or 56 kbps

## Power Requirements

Voltage

PCI-1428.....+5 V (1.5 A)  
+12 V (24 mA)  
-12 V (20 mA)

PXI-1428 .....+5 V (250 mA)  
+3.3 V (1.2 A)

## Physical

Dimensions

PCI-1428.....10.7 cm × 17.5 cm  
(4.2 in. × 6.9 in.)

PXI-1428 .....10 cm × 16 cm  
(3.9 in. × 6.3 in.)

---

<sup>1</sup> This value corresponds to the post-serialization Camera Link cable transmission rate of 140 to 350 MHz.



**Weight**

PCI-1428 .....	0.127 kg (0.28 lb)
PXI-1428.....	0.172 kg (0.38 lb)

**Environment**

The IMAQ 1428 device is intended for indoor use only.

Operating temperature..... 0 to 55 °C

Storage temperature ..... –20 to 70 °C

Maximum altitude ..... 2,000 m

Pollution Degree ..... 2

Relative humidity ..... 5 to 90%, noncondensing

**Safety**

The IMAQ 1428 meets the requirements of the following standards for safety and electrical equipment for measurement, control, and laboratory use:

- EN 61010-1, IEC 61010-1
- UL 3111-1, UL 61010B-1
- CAN/CSA C22.2 No. 1010.1



**Note** For UL and other safety certifications, refer to the product label, or visit [ni.com/hardref.nsf](http://ni.com/hardref.nsf), search by model number or product line, and click the appropriate link in the Certification column.

**Electromagnetic Compatibility**

Emissions ..... EN 55011 Class A at 10 m  
FCC Part 15A above 1 GHz

Immunity ..... EN 61326: 1997/ A2:2001,  
Table 1

CE, C-Tick, and FCC Part 15 (Class A) Compliant



**Note** For EMC compliance, operate this device with shielded cabling. In addition, all covers and filler panels *must* be installed. Refer to the Declaration of Conformity (DoC) for this product for any additional regulatory compliance information. To obtain the DoC

for this product, visit [ni.com/hardref.nsf](http://ni.com/hardref.nsf), search by model number or product line, and click the appropriate link in the Certification column.

## Cabling

This appendix contains cabling requirements for the IMAQ 1428, including Camera Link cable ordering information.

### 68-Pin VHDCI Cable Specifications

National Instruments offers cables and accessories for connecting to video sources, trigger sources, or synchronization sources. However, if you want to develop your own cable for the 68-pin VHDCI connector, you must use twisted pairs for each signal.

If you are using the IMAQ D6826 breakout cable, refer to Figure B-1 for the MDR 26-pin medium configuration Camera Link connector pinout. Refer to Figure B-2 for the 25-pin D-SUB trigger connector pinout.



**Note** Refer to the following connector pinouts only if you are using the IMAQ D6826 breakout cable. If you are not using this cable, refer to Chapter 4, [Signal Connections](#), for the standard MDR 26-pin connector pinout.

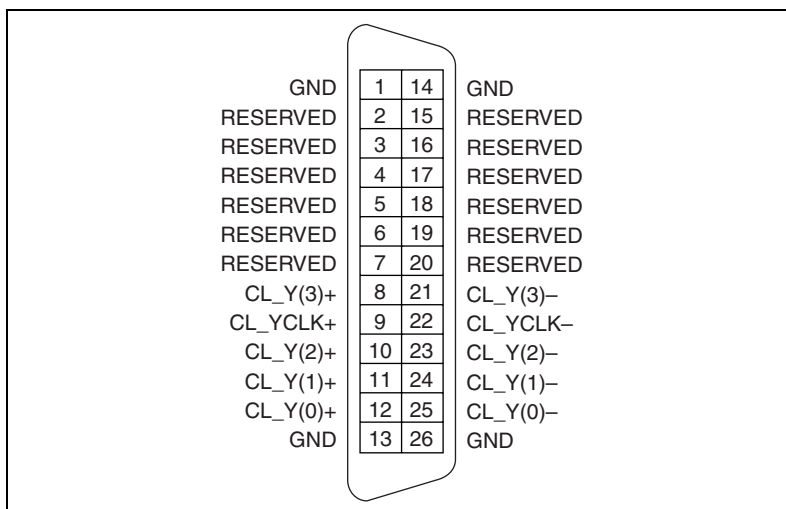

**Figure B-1.** 26-Pin MDR Medium Configuration Camera Link Connector

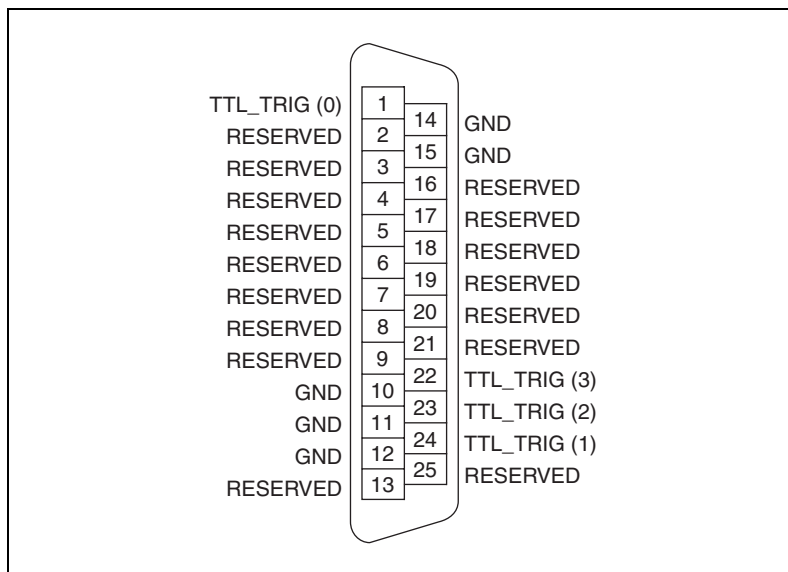

**Figure B-2.** 25-Pin D-SUB Trigger Connector

For information about additional connector pin assignments, refer to the [Connectors](#) section of Chapter 4, [Signal Connections](#).

## Camera Link Cables

Use a 3M Camera Link cable to connect your camera to the MDR 26-pin connector on the IMAQ 1428 device. Camera Link cables consist of two MDR-26 male plugs linked with a twin-axial shielded cable and are available in two shell configurations.



**Note** National Instruments recommends purchasing a Camera Link cable. Building your own cable is not recommended due to the high-speed signaling on the Camera Link interface.

For more information on Camera Link cables, refer to the *Specifications of the Camera Link Interface Standard for Digital Cameras and Frame Grabbers* manual. This manual is available on several Web sites, including the Automated Imaging Association site at [www.machinevisiononline.org](http://www.machinevisiononline.org).

Figure B-3 illustrates the Camera Link cable.

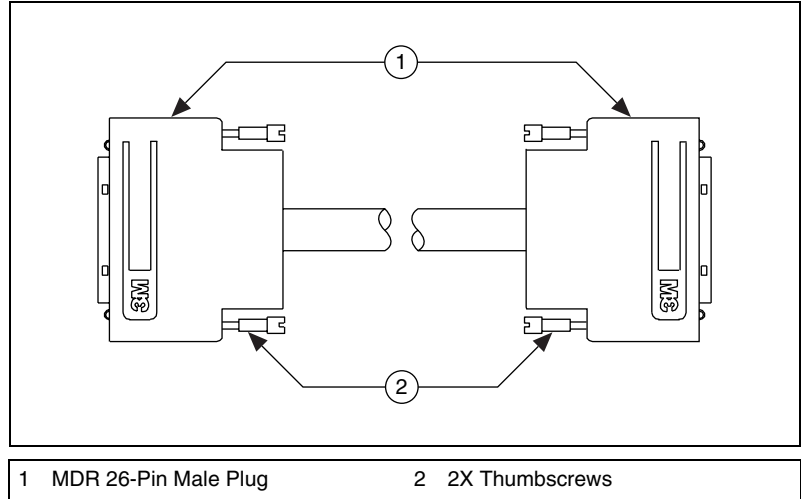
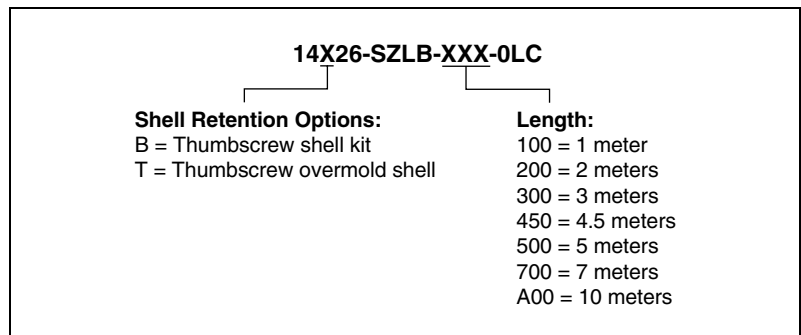

**Figure B-3.** Camera Link Cable

## Ordering Information

Camera Link cables are manufactured by 3M corporation and are available from both National Instruments and 3M.

Two-meter Camera Link cables (part number 187676-02) are available from the National Instruments Web site at [ni.com/catalog](http://ni.com/catalog). Camera Link cables are available in 1 to 10 m lengths from the 3M Web site at [www.3m.com](http://www.3m.com). Refer to Figure B-4 for 3M part number information.



**Figure B-4.** 3M Part Number Ordering Information



---

# Technical Support and Professional Services

Visit the following sections of the National Instruments Web site at [ni.com](http://ni.com) for technical support and professional services:

- **Support**—Online technical support resources at [ni.com/support](http://ni.com/support) include the following:
  - **Self-Help Resources**—For immediate answers and solutions, visit the award-winning National Instruments Web site for software drivers and updates, a searchable KnowledgeBase, product manuals, step-by-step troubleshooting wizards, thousands of example programs, tutorials, application notes, instrument drivers, and so on.
  - **Free Technical Support**—All registered users receive free Basic Service, which includes access to hundreds of Application Engineers worldwide in the NI Developer Exchange at [ni.com/exchange](http://ni.com/exchange). National Instruments Application Engineers make sure every question receives an answer.
- **Training and Certification**—Visit [ni.com/training](http://ni.com/training) for self-paced training, eLearning virtual classrooms, interactive CDs, and Certification program information. You also can register for instructor-led, hands-on courses at locations around the world.
- **System Integration**—If you have time constraints, limited in-house technical resources, or other project challenges, NI Alliance Program members can help. To learn more, call your local NI office or visit [ni.com/alliance](http://ni.com/alliance).
- **Declaration of Conformity (DoC)**—A DoC is our claim of compliance with the Council of the European Communities using the manufacturer’s declaration of conformity. This system affords the user protection for electronic compatibility (EMC) and product safety. You can obtain the DoC for your product by visiting [ni.com/hardref.nsf](http://ni.com/hardref.nsf).
- **Calibration Certificate**—If your product supports calibration, you can obtain the calibration certificate for your product at [ni.com/calibration](http://ni.com/calibration).

If you searched [ni.com](http://ni.com) and could not find the answers you need, contact your local office or NI corporate headquarters. Phone numbers for our worldwide offices are listed at the front of this manual. You also can visit the Worldwide Offices section of [ni.com/niglobal](http://ni.com/niglobal) to access the branch office Web sites, which provide up-to-date contact information, support phone numbers, email addresses, and current events.

# Glossary

---

## A

acquisition window	The image size specific to a video standard or camera resolution.
active line region	The region of lines actively being stored. Defined by a line start (relative to the vertical synchronization signal) and a line count.
active pixel region	The region of pixels actively being stored. Defined by a pixel start (relative to the horizontal synchronization signal) and a pixel count.
API	Application programming interface.
area	A rectangular portion of an acquisition window or frame that is controlled and defined by software.
ASIC	Application-Specific Integrated Circuit. A proprietary semiconductor component designed and manufactured to perform a set of specific functions for specific customer needs.

## B

buffer	Temporary storage for acquired data.
bus	A group of conductors that interconnect individual circuitry in a computer, such as the PCI bus; typically the expansion vehicle to which I/O or other devices are connected.

## C

Camera Link	Interface standard for digital video data and camera control based on the Channel Link chipset.
Channel Link	National Semiconductor chipset for high-speed data serialization and deserialization for transmission across cables up to 10 m.



## D

- DAQ** Data acquisition. (1) Collecting and measuring electrical signals from sensors, transducers, and test probes or fixtures and inputting them to a computer for processing. (2) Collecting and measuring the same kinds of electrical signals with A/D or DIO boards plugged into a computer, and possibly generating control signals with D/A and/or DIO boards in the same computer.
- DMA** Direct memory access. A method by which data can be transferred to and from computer memory from and to a device or memory on the bus while the processor does something else; DMA is the fastest method of transferring data to/from computer memory.
- drivers** Software that controls a specific hardware device, such as an image acquisition board.

## F

- FIFO** First-in first-out memory buffer. The first data stored is the first data sent to the acceptor; FIFOs are used on IMAQ devices to temporarily store incoming data until that data can be retrieved.

## I

- I/O** Input/output. The transfer of data to/from a computer system involving communications channels, operator interface devices, and/or data acquisition and control interfaces.

## L

- LUT** Look-up table. Table containing values used to transform the gray-level values of an image. For each gray-level value in the image, the corresponding new value is obtained from the look-up table.
- LVDS** Low Voltage Differential Signaling (EIA-644).

**M**

**mux** Multiplexer. A switching device with multiple inputs that selectively connects one of its inputs to its output.

**N**

**NI-IMAQ** Driver software for National Instruments IMAQ hardware.

**P**

**PCI** Peripheral Component Interconnect. A high-performance expansion bus architecture originally developed by Intel to replace ISA and EISA. PCI offers a theoretical maximum transfer rate of 133 Mbytes/s.

**pixel** Picture element. The smallest division that makes up the video scan line; for display on a computer monitor, a pixel's optimum dimension is square (aspect ratio of 1:1, or the width equal to the height).

**pixel clock** Divides the incoming horizontal video line into pixels.

**protocol** The exact sequence of bits, characters, and control codes used to transfer data between computers and peripherals through a communications channel.

**R**

**RAM** Random-access memory.

**real time** A property of an event or system in which data is processed as it is acquired instead of being accumulated and processed at a later time.

**resolution** The smallest signal increment that can be detected by a measurement system. Resolution can be expressed in bits, in proportions, or in percent of full scale. For example, a system has 12-bit resolution, one part in 4,096 resolution, and 0.0244 percent of full scale.

**RGB** Color encoding scheme using red, green, and blue (RGB) color information where each pixel in the color image is encoded using 32 bits: eight bits for red, eight bits for green, eight bits for blue, and eight bits for the alpha value (unused).

**ROI** Region of interest. A hardware-programmable rectangular portion of the acquisition window.

**RTSI bus** Real-Time System Integration Bus. The National Instruments timing bus that connects IMAQ and DAQ devices directly, by means of connectors on the devices, for precise synchronization of functions.

## **S**

**scatter-gather DMA** A type of DMA that allows the DMA controller to reconfigure on-the-fly.

**SDRAM** Synchronous dynamic RAM.

## **T**

**tap** A stream of pixels from a camera. Some cameras send multiple streams, or taps, of data over a cable simultaneously to increase transfer rate.

**transfer rate** The rate, measured in bytes/s, at which data is moved from source to destination after software initialization and set up operations. The maximum rate at which the hardware can operate.

**trigger** Any event that causes or starts some form of data capture.

**trigger control and mapping circuitry** Circuitry that routes, monitors, and drives external and RTSI bus trigger lines. You can configure each of these lines to start or stop acquisition on a rising or falling edge.

**TTL** Transistor-transistor logic.

## **V**

**VI** Virtual Instrument. (1) A combination of hardware and/or software elements, typically used with a PC, that has the functionality of a classic stand-alone instrument. (2) A LabVIEW software module (VI), which consists of a front panel user interface and a block diagram program.

# Index

---

## Numerics

- 68-pin VHDCI connector, 4-2
  - cable specifications, B-1
  - overview, 4-2
  - pin assignments (figure), 4-3

## A

- acquisition and region of interest (ROI)
  - circuitry, 3-4
- acquisition start conditions, 3-5
- acquisition window control, 3-5
  - active pixel region (acquisition window), 3-5
  - region of interest, 3-5
- application software, Vision Development Module, 1-4

## B

- Base configuration, Camera Link, 3-2
- block diagram of IMAQ 1428 (figure), 3-1
- bus master PCI interface, 3-4

## C

- cabling
  - 68-pin VHDCI cable specifications, B-1
  - Camera Link cable (figure), B-3
  - Camera Link cables, B-2
- calibration certificate (NI resources), C-1
- Camera Link
  - Base configuration, 3-2
  - cabling
    - description, B-2
    - ordering information, B-3

- Medium configuration, 3-2
  - overview, 1-2
- CC<4..1> $\pm$  signal (table), 4-4
- CHASSIS\_GND signal (table), 4-4
- clock signals
  - XCLK $\pm$  signal (table), 4-4
  - YCLK $\pm$  signal (table), 4-4
- clock specifications, A-2
- configuration
  - Camera Link
    - Base configuration, 3-2
    - Medium configuration, 3-2
  - configuring the IMAQ 1428, 2-6
  - installation, 2-5
- connectors
  - 68-pin VHDCI connector, 4-3
  - I/O connector signals (table), 4-4
  - IMAQ 1428 connectors (figure), 4-1
  - MDR 26-pin connector (figure), 4-2
  - signal description (table), 4-4
- conventions used in manual, v

## D

- data formatter, multiple tap, 3-3
- data transmission, 3-2
- Declaration of Conformity (NI resources), C-1
- delayed acquisition start conditions, 3-5
- DGND signal (table), 4-4
- diagnostic tools (NI resources), C-1
- DMA controllers, 3-4
- documentation
  - conventions used in the manual, v
  - NI resources, C-1
- drivers (NI resources), C-1

## E

- electromagnetic compatibility
  - specifications, A-3
- environment specifications, A-3
- equipment, optional, 2-2
- examples (NI resources), C-1
- external connection specifications, A-1

## G

- getting started with the IMAQ 1428, 2-1

## H

- hardware overview, 3-1
  - acquisition window control, 3-5
  - acquisition, region of interest (ROI), 3-4
  - block diagram (figure), 3-1
  - bus master PCI interface, 3-4
  - Camera Link, 3-2
    - Base configuration, 3-2
    - Medium configuration, 3-2
  - data transmission, 3-2
  - high-speed timing, 3-4
  - LUTs, 3-3
  - multiple-tap data formatter, 3-3
  - scatter-gather DMA controllers, 3-4
  - SDRAM, 3-3
  - serial interface, 3-5
  - start conditions, 3-5
  - trigger control and mapping circuitry, 3-3
- help, technical support, C-1
- high-speed timing circuitry, 3-4

## I

- I/O connector. *See* connectors
- IMAQ PCI/PXI-1428
  - Camera Link, 1-2
  - configuration, 2-6
  - installation, 2-5

- interfacing with, 2-7
- optional equipment, 2-2
- overview and features, 1-1
- requirements for getting started, 2-1
- software programming choices, 1-3
  - integration with DAQ, 1-5
  - National Instruments application software, 1-4
  - NI-IMAQ driver software, 1-3
  - Vision and Motion, 1-5
  - Vision Builder for Automated Inspection, 1-4
  - Vision Development Module, 1-4
- unpacking, 2-2

## installation

- cabling, B-1
  - 68-pin VHDCI cable specifications, B-1
  - Camera Link cables, B-2
- hardware, 2-5
- procedure, 2-5
- unpacking, 2-2

- instrument drivers (NI resources), C-1
- integration with DAQ and motion control, 1-5

## K

- KnowledgeBase, C-1

## L

- LabVIEW, Vision Builder AI, 1-4
- LUTs (lookup tables), 3-3

## M

- mapping circuitry, 3-3
- MDR 26-pin connector, 4-2
- Medium configuration, Camera Link, 3-2
- memory, A-2

motion control, integrating with, 1-5  
 multiple-tap data formatter, 3-3

## N

National Instruments application software, 1-4  
 National Instruments support and services, C-1  
 NI-IMAQ driver software, 1-3

## O

optional equipment, 2-2

## P

PCI Interface, A-2  
 PCI-1428  
   installation, 2-5  
   interfacing with, 2-7  
 physical specifications, A-2  
 power requirements, A-2  
 programming examples (NI resources), C-1  
 PXI-1428  
   installation, 2-6  
   interfacing with, 2-7

## R

Real-Time System Integration (RTSI) bus, 1-1  
 region of interest (ROI) circuitry, 3-4  
 region of interest, in acquisition window control, 3-5  
 requirements for getting started, 2-1

## S

safety specifications, A-3  
 scatter-gather DMA controllers, 3-4  
 SDRAM, 3-3

serial interface, 3-5  
 serial requirements, A-2  
 SerTC $\pm$  signal (table), 4-4  
 SerTFG $\pm$  signal (table), 4-4  
 signal connections, 4-1  
   connectors  
     68-pin VHDCI connector, 4-2  
     IMAQ 1428 connectors (figure), 4-1  
     MDR 26-pin connector, 4-2  
     signal descriptions, 4-4  
 software (NI resources), C-1  
 software controlled start conditions, 3-5  
 software programming choices, 1-3  
   integration with DAQ, 1-5  
   National Instruments IMAQ Vision, 1-4  
   NI-IMAQ driver software, 1-3  
   Vision and Motion, 1-5  
   Vision Builder for Automated Inspection, 1-4  
   Vision Development Module, 1-4  
 software, Vision Development Module, 1-4  
 specifications  
   clocks, A-2  
   electromagnetic compatibility, A-3  
   environment, A-3  
   external connections, A-1  
   memory, A-2  
   PCI interface, A-2  
   physical, A-2  
   power requirements, A-2  
   safety, A-3  
   serial requirements, A-2  
 start conditions  
   delayed acquisition, 3-5  
   software control, 3-5  
   trigger control, 3-5  
 support, technical, C-1

## T

- technical support, C-1
- timing circuitry, high-speed, 3-4
- training and certification (NI resources), C-1
- trigger control and mapping circuitry, 3-3
- trigger controlled start conditions, 3-5
- troubleshooting (NI resources), C-1
- TTL\_TRIG signal (table), 4-4

## U

- unpacking the IMAQ 1428, 2-2

## V

- VHDCI connector, 68-pin, 4-2
  - cable specifications, B-1
  - overview, 4-2
  - pin assignments (figure), 4-3

## W

- Web resources, C-1

## X

- X<3..0>± signal (table), 4-4
- XCLK± signal (table), 4-4

## Y

- Y<3..0> signal (table), 4-4
- YCLK± signal (table), 4-4