

COMPREHENSIVE SERVICES

We offer competitive repair and calibration services, as well as easily accessible documentation and free downloadable resources.

SELL YOUR SURPLUS

We buy new, used, decommissioned, and surplus parts from every NI series. We work out the best solution to suit your individual needs.

 Sell For Cash  Get Credit  Receive a Trade-In Deal

OBSOLETE NI HARDWARE IN STOCK & READY TO SHIP

We stock **New**, **New Surplus**, **Refurbished**, and **Reconditioned** NI Hardware.



Bridging the gap between the manufacturer and your legacy test system.

 1-800-915-6216

 www.apexwaves.com

 sales@apexwaves.com

All trademarks, brands, and brand names are the property of their respective owners.

Request a Quote

 **CLICK HERE**

PXI-2515

DEVICE SPECIFICATIONS

NI PXI/PXIe-2515

High-Speed Digital Signal Insertion Switch

This document lists specifications for the NI PXI/PXIe-2515 (NI 2515) high-speed digital signal insertion switch. The NI 2515 is intended for use with compatible single-ended NI high-speed DIO devices. Refer to the [NI Switches Help](#) for a list of supported NI high-speed DIO devices. These specifications are valid within the operating temperature range. All specifications are subject to change without notice. Visit ni.com/manuals for the most current specifications.

The minimum software requirements are:

- NI-SWITCH 4.0
- NI-DAQmx 9.0

Topology.....Independent

Refer to the [NI Switches Help](#) for detailed topology information.



Caution The protection provided by the NI 2515 can be impaired if it is used in a manner not described in this document.

Contents

About These Specifications.....	2
Input Characteristics.....	2
Dynamic Characteristics.....	3
Trigger Characteristics.....	4
Physical Characteristics.....	4
Environment.....	5
Shock and Vibration.....	5
Diagrams.....	5
Accessories.....	7
Estimating Reed Relay Life.....	8
Estimating Reed Relay Life Example.....	8
Solution.....	8
Compliance and Certifications.....	9
Safety.....	9
Electromagnetic Compatibility.....	10
CE Compliance.....	10
Online Product Certification.....	10
Environmental Management.....	10

About These Specifications

Maximum and *minimum* specifications are warranted not to exceed these values within certain operating conditions and include the effects of temperature and uncertainty unless otherwise noted.

Typical specifications are unwarranted values that are representative of a majority (90%) of units within certain operating conditions and include the effects of temperature and uncertainty unless otherwise noted.

Characteristic specifications are unwarranted values that are representative of an average unit operating at room temperature.

All specifications are *characteristic* unless otherwise specified.

Nominal specifications are unwarranted values that are relevant to the use of the product and convey the expected performance of the product.

Input Characteristics

All input characteristics are DC, AC_{pk}, or a combination unless otherwise specified.

Maximum switching voltage

Channel-to-ground.....30 V, CAT I¹



Caution When hazardous voltages (>42.4 V_{pk}/60 VDC) are present on any relay terminal, safety low-voltage (<42.4 V_{pk}/60 VDC) cannot be connected to any other relay terminal.



Caution The maximum switching power is limited by the maximum switching current and the maximum voltage, and must not exceed 3 W.

Maximum switching power.....3 W
(per channel)

Maximum switching current.....0.25 A

Maximum carry current.....0.3 A

Typical skew

Channel-to-channel.....<130 ps (across all data channels)

Channel-to-control.....<290 ps (across all data and control channels)

¹ Measurement Categories CAT I and CAT O (Other) are equivalent. These test and measurement circuits are not intended for direct connection to the MAINS building installations of Measurement Categories CAT II, CAT III, or CAT IV.

Maximum DC path resistance (at 25 °C)

Initial (CH x - DUT x).....	<2 Ω
End-of-life (CH x - DUT x).....	≥3 Ω
Initial (Analog bus).....	<5 Ω
End-of-life (Analog bus).....	≥6 Ω



Note DC path resistance typically remains low for the life of the relay. At the end of relay life, the path resistance rapidly rises above the end of life value. Load ratings apply to relays used within the specification before the end of relay life.

Characteristic analog bus offset.....<50 μV
voltage

Characteristic analog bus leakage.....<2 nA
current

Characteristic analog bus bandwidth.....50 MHz
(3 dB, 50 Ω termination)

Characteristic crosstalk.....<-10 dB
(50 Ω termination) <600 MHz

Characteristic open channel isolation.....>20 dB
(50 Ω termination) <600 MHz

Dynamic Characteristics

Maximum simultaneous drive limit.....48 relays
for PXI/PXI Express

Nominal relay operate time.....0.25 ms



Note Certain applications may require additional time for proper settling. Refer to the [NI Switches Help](#) for more information about including additional settling time.

Nominal release time.....0.05 ms

Nominal expected relay life, electrical
(resistive)

1 V, 10 mA.....	1×10^9 cycles
5 V, 10 mA.....	1×10^8 cycles



Note Reed relays are highly susceptible to damage caused by switching capacitive and inductive loads. Capacitive loads can cause high inrush currents while inductive loads can cause high flyback voltages. The addition of appropriate resistive protection can greatly improve contact lifetime. For more information about adding

protection circuitry to a capacitive load, visit ni.com/info and enter the Info Code `relaylifetime`. For information about inductive loads, enter the Info Code `relayflyback`.

Trigger Characteristics

Input trigger

Sources.....PXI trigger lines <0..7>
Minimum pulse width.....150 ns



Note The NI 2515 can recognize trigger pulse widths less than 150 ns if you disable digital filtering. Refer to the [NI Switches Help](#) for information about disabling digital filtering.

Output trigger

Destinations.....PXI trigger lines <0..7>
Pulse width.....Programmable (1 μ s to 62 μ s)

Physical Characteristics

Relay type.....Reed



Note NI advises against installing reed relay modules directly adjacent to an embedded controller with a magnetic hard drive because of the sensitivity of reed relays and the possibility of interference from magnetic hard drives.

Relay contact material.....Rhodium

I/O connectors.....2, BNC female and 2, VHDCI female

Characteristic power requirement

PXI

5 V.....9.1 W
3.3 V.....0.45 W

PXI Express

12 V.....8.4 W
3.3 V.....0.8 W



Note The maximum power requirements depend on how many relays are closed at the same time.

Dimensions (L × W × H).....	3U, one slot, PXI/cPCI module, PXI Express compatible 21.6 cm × 2.0 cm × 13.0 cm (8.5 in. × 0.8 in. × 5.1 in.)
Weight.....	248 g (8.7 oz)

Environment

Operating temperature.....	0 °C to 55 °C
Storage temperature.....	-40 °C to 70 °C
Relative humidity.....	5% to 85%, noncondensing
Pollution Degree.....	2
Maximum altitude.....	2,000 m

Indoor use only.

Shock and Vibration

Operational Shock.....	30 g peak, half-sine, 11 ms pulse (Tested in accordance with IEC 60068-2-27. Test profile developed in accordance with MIL-PRF-28800F.)
Random Vibration	
Operating.....	5 Hz to 500 Hz, 0.3 g _{rms}
Nonoperating.....	5 Hz to 500 Hz, 2.4 g _{rms} (Tested in accordance with IEC 60068-2-64. Nonoperating test profile exceeds the requirements of MIL-PRF-28800F, Class 3.)

Diagrams

The following figure shows the NI 2515 power-on state.

Figure 1. NI 2515 Power-On State

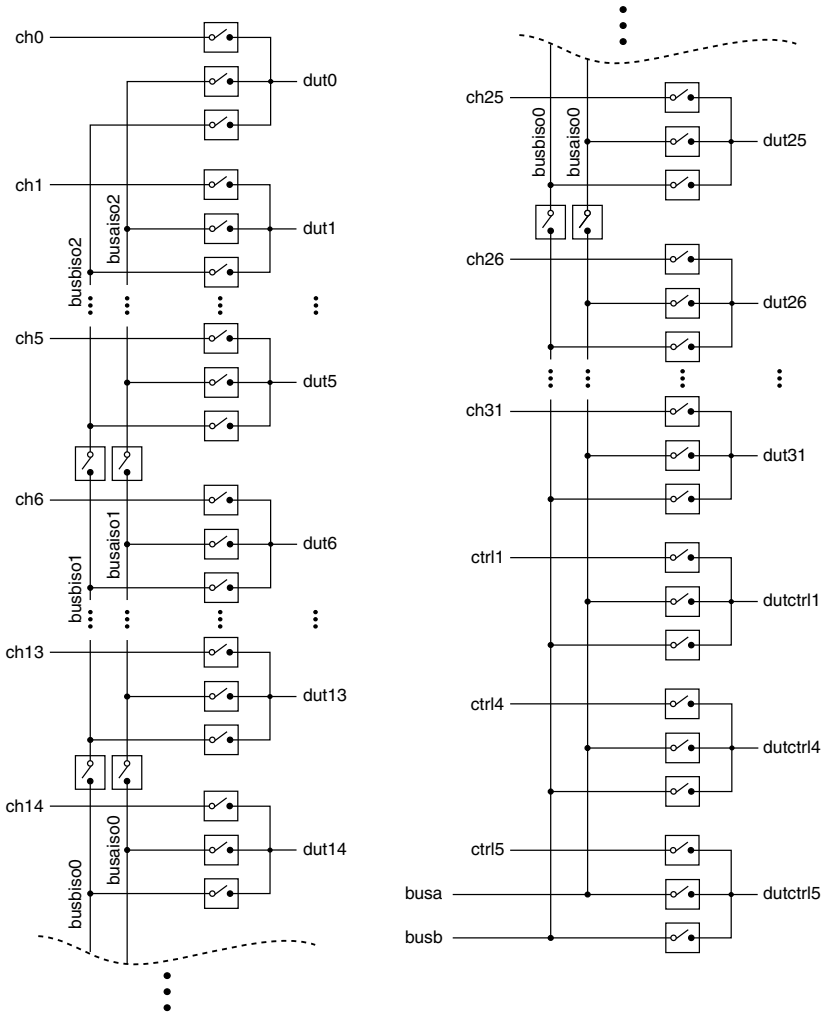

The following figure shows the NI 2515 connector pinout.

Figure 2. NI 2515 Connector Pinout

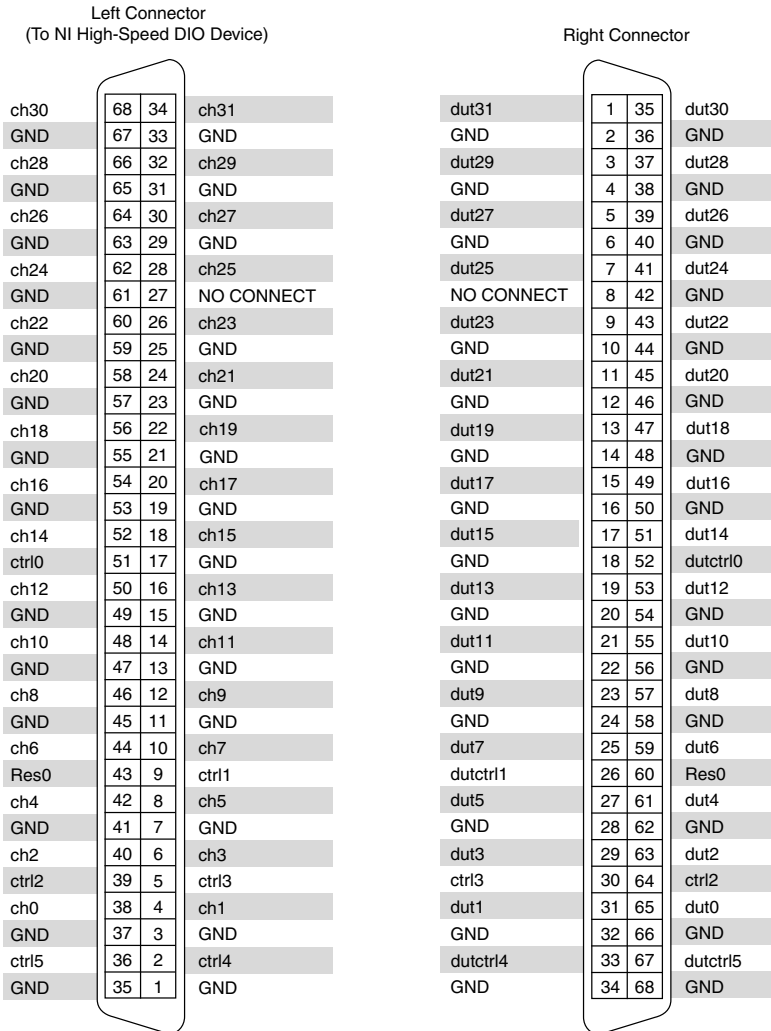

Accessories

Visit ni.com for more information about the following accessories.

Table 1. NI Accessories for the NI 2515

Accessory	Part number
SHC68-C68-D5 Cable for NI 2515 HSDIO Signal Insertion 0.5 m	781362-01
SHC68-C68-D4 Shielded Single-Ended Cable for HSDIO, 0.5 m	781013-01
SHC68-C68-D4 Shielded Single-Ended Cable, 1 m	196275-01
SMB-2163 Single-Ended Digital I/O Accessory (Rack-Mountable)	778747-01
SHC68-H1X38 High-Speed Digital Flying-Leads Cable Accessory, 1.5 m	192681-1R5
CB-2162 Single-Ended Digital I/O Accessory	778592-01
BNC to Bare Wire Cable	781631-01

You must install mating connectors according to local safety codes and standards and according to the specifications provided by the manufacturer. You are responsible for verifying the safety compliance of third-party connectors and their usage according to the relevant standard(s), including UL and CSA in North America and IEC and VDE in Europe.

Estimating Reed Relay Life

Complete the following steps to estimate relay lifetimes using the nomograph:

1. Determine the peak voltage experienced across the relay while switching and mark this value on the *Volts* line.
2. Determine the sum of the DUT, cable, and instrumentation capacitances and mark this value on the *Load Capacitance* line.
3. Draw a straight line between both values.

The intersection points of this line and the *No Protection* and *50 Ω Protection* axes are the corresponding estimated relay lifetimes in cycles.

Estimating Reed Relay Life Example

The reed relay module is connected to a DMM through 1 meter of cable. The DMM and cable capacitances are 100 pF and 30 pF respectively. The maximum voltage switched across the relay is 50 V. Determine the estimated number of relay cycles with and without protection resistance.

Solution

The total load capacitance is the sum of the cable and DMM capacitance, which is 130 pF. Draw a line between the 50 V point on the *Volts* axis and 130 pF on the *Load Capacitance* axis.

The line drawn intersects the *Cycles* axes at approximately 500,000 on the *No Protection* axis and about 25,000,000 on the *50 Ω Protection* axis, as shown in the following figure. This series resistance should be placed as close as possible to the relay for maximum effect.

Figure 3. Reed Relay Lifetime Nomograph

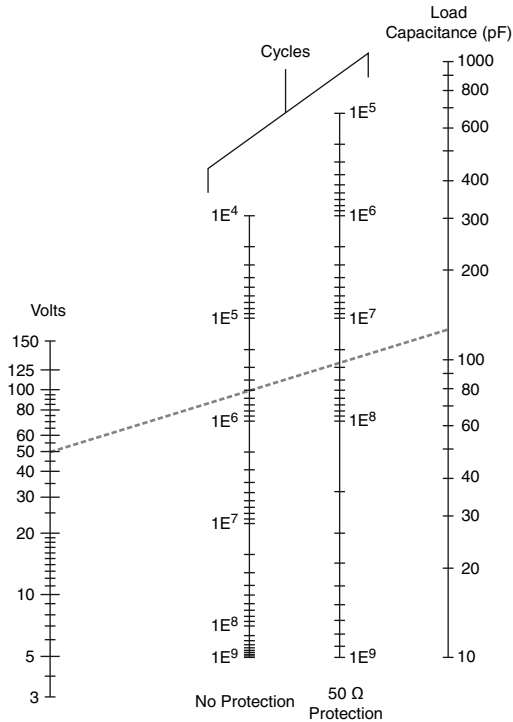

Compliance and Certifications

Safety

This product is designed to meet the requirements of the following electrical equipment safety standards for measurement, control, and laboratory use:

- IEC 61010-1, EN 61010-1
- UL 61010-1, CSA 61010-1



Note For UL and other safety certifications, refer to the product label or the [Online Product Certification](#) section.

Electromagnetic Compatibility

This product meets the requirements of the following EMC standards for electrical equipment for measurement, control, and laboratory use:

- EN 61326-1 (IEC 61326-1): Class A emissions; Basic immunity
- EN 55011 (CISPR 11): Group 1, Class A emissions
- AS/NZS CISPR 11: Group 1, Class A emissions
- FCC 47 CFR Part 15B: Class A emissions
- ICES-001: Class A emissions



Note In the United States (per FCC 47 CFR), Class A equipment is intended for use in commercial, light-industrial, and heavy-industrial locations. In Europe, Canada, Australia, and New Zealand (per CISPR 11), Class A equipment is intended for use only in heavy-industrial locations.



Note Group 1 equipment (per CISPR 11) is any industrial, scientific, or medical equipment that does not intentionally generate radio frequency energy for the treatment of material or inspection/analysis purposes.



Note For EMC declarations, certifications, and additional information, refer to the [Online Product Certification](#) section.

CE Compliance

This product meets the essential requirements of applicable European Directives, as follows:

- 2006/95/EC; Low-Voltage Directive (safety)
- 2004/108/EC; Electromagnetic Compatibility Directive (EMC)

Online Product Certification

Refer to the product Declaration of Conformity (DoC) for additional regulatory compliance information. To obtain product certifications and the DoC for this product, visit ni.com/certification, search by model number or product line, and click the appropriate link in the Certification column.

Environmental Management

NI is committed to designing and manufacturing products in an environmentally responsible manner. NI recognizes that eliminating certain hazardous substances from our products is beneficial to the environment and to NI customers.

For additional environmental information, refer to the *Minimize Our Environmental Impact* web page at ni.com/environment. This page contains the environmental regulations and directives with which NI complies, as well as other environmental information not included in this document.

Waste Electrical and Electronic Equipment (WEEE)



EU Customers At the end of the product life cycle, all NI products must be disposed of according to local laws and regulations. For more information about how to recycle NI products in your region, visit ni.com/environment/weee.

电子信息产品污染控制管理办法（中国 RoHS）



中国客户 National Instruments 符合中国电子信息产品中限制使用某些有害物质指令 (RoHS)。关于 National Instruments 中国 RoHS 合规性信息，请登录 ni.com/environment/rohs_china。(For information about China RoHS compliance, go to ni.com/environment/rohs_china.)

Refer to the *NI Trademarks and Logo Guidelines* at ni.com/trademarks for information on National Instruments trademarks. Other product and company names mentioned herein are trademarks or trade names of their respective companies. For patents covering National Instruments products/technology, refer to the appropriate location: **Help»Patents** in your software, the `patents.txt` file on your media, or the *National Instruments Patent Notice* at ni.com/patents. You can find information about end-user license agreements (EULAs) and third-party legal notices in the readme file for your NI product. Refer to the *Export Compliance Information* at ni.com/legal/export-compliance for the National Instruments global trade compliance policy and how to obtain relevant HTS codes, ECCNs, and other import/export data. NI MAKES NO EXPRESS OR IMPLIED WARRANTIES AS TO THE ACCURACY OF THE INFORMATION CONTAINED HEREIN AND SHALL NOT BE LIABLE FOR ANY ERRORS.

U.S. Government Customers: The data contained in this manual was developed at private expense and is subject to the applicable limited rights and restricted data rights as set forth in FAR 52.227-14, DFAR 252.227-7014, and DFAR 252.227-7015.