

COMPREHENSIVE SERVICES

We offer competitive repair and calibration services, as well as easily accessible documentation and free downloadable resources.

SELL YOUR SURPLUS

We buy new, used, decommissioned, and surplus parts from every NI series. We work out the best solution to suit your individual needs.

 Sell For Cash  Get Credit  Receive a Trade-In Deal

OBSOLETE NI HARDWARE IN STOCK & READY TO SHIP

We stock **New**, **New Surplus**, **Refurbished**, and **Reconditioned** NI Hardware.



Bridging the gap between the manufacturer and your legacy test system.

 1-800-915-6216

 www.apexwaves.com

 sales@apexwaves.com

All trademarks, brands, and brand names are the property of their respective owners.

Request a Quote

 **CLICK HERE**

PXI-6653

USER GUIDE

Multi-Device PXI_Clk10 Disciplining Software

This document explains how to install and use the Multi-Device PXI_Clk10 Disciplining software.

Introduction, Installation, and Configuration

About the Multi-Device PXI_Clk10 Disciplining Software

This software provides a LabVIEW library to synchronize PXI_Clk10 to external time references.

Hardware Requirements

Figures 1 and 2 show the Multi-Device PXI_Clk10 Disciplining software hardware requirements.

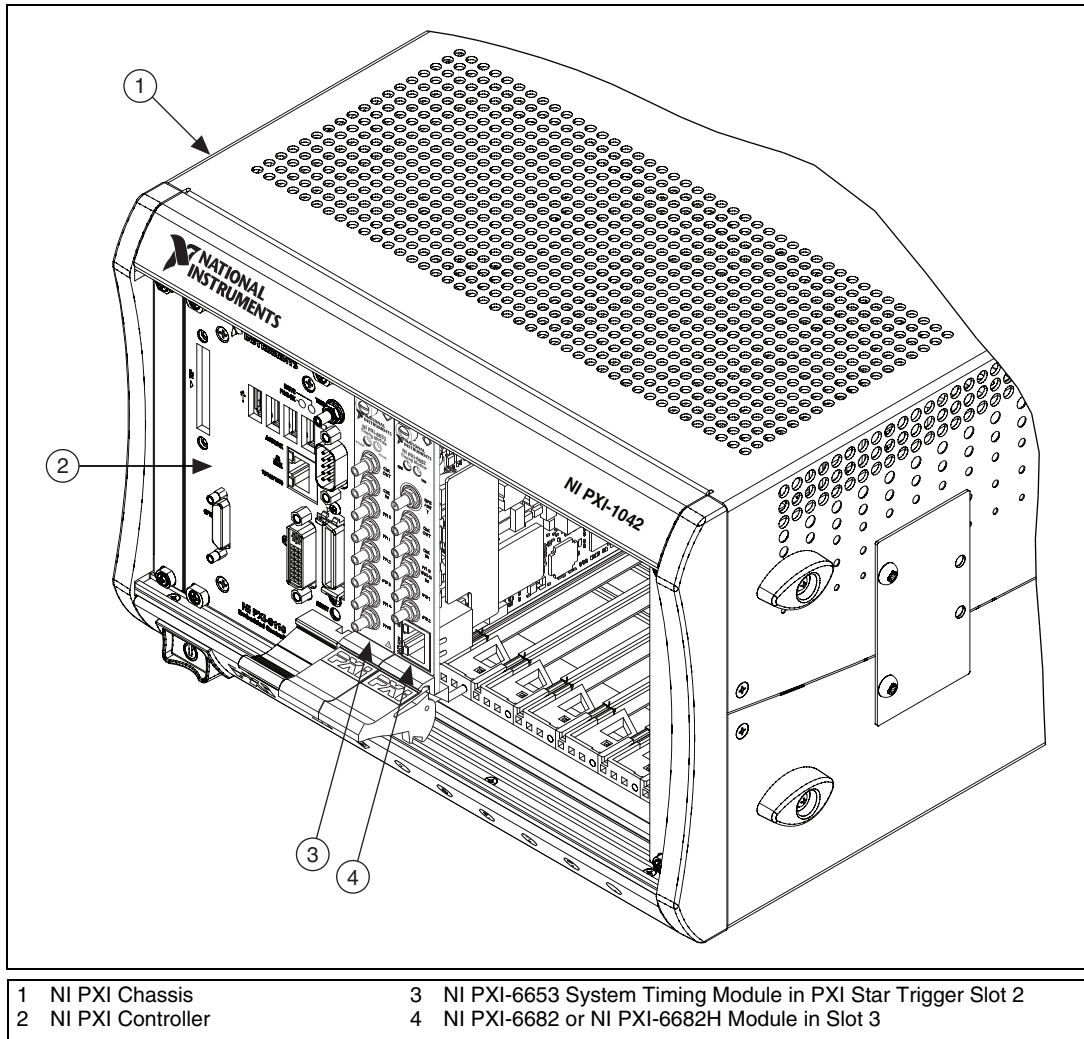

Figure 1. Hardware Requirements for the NI PXI-6653 System Timing Module

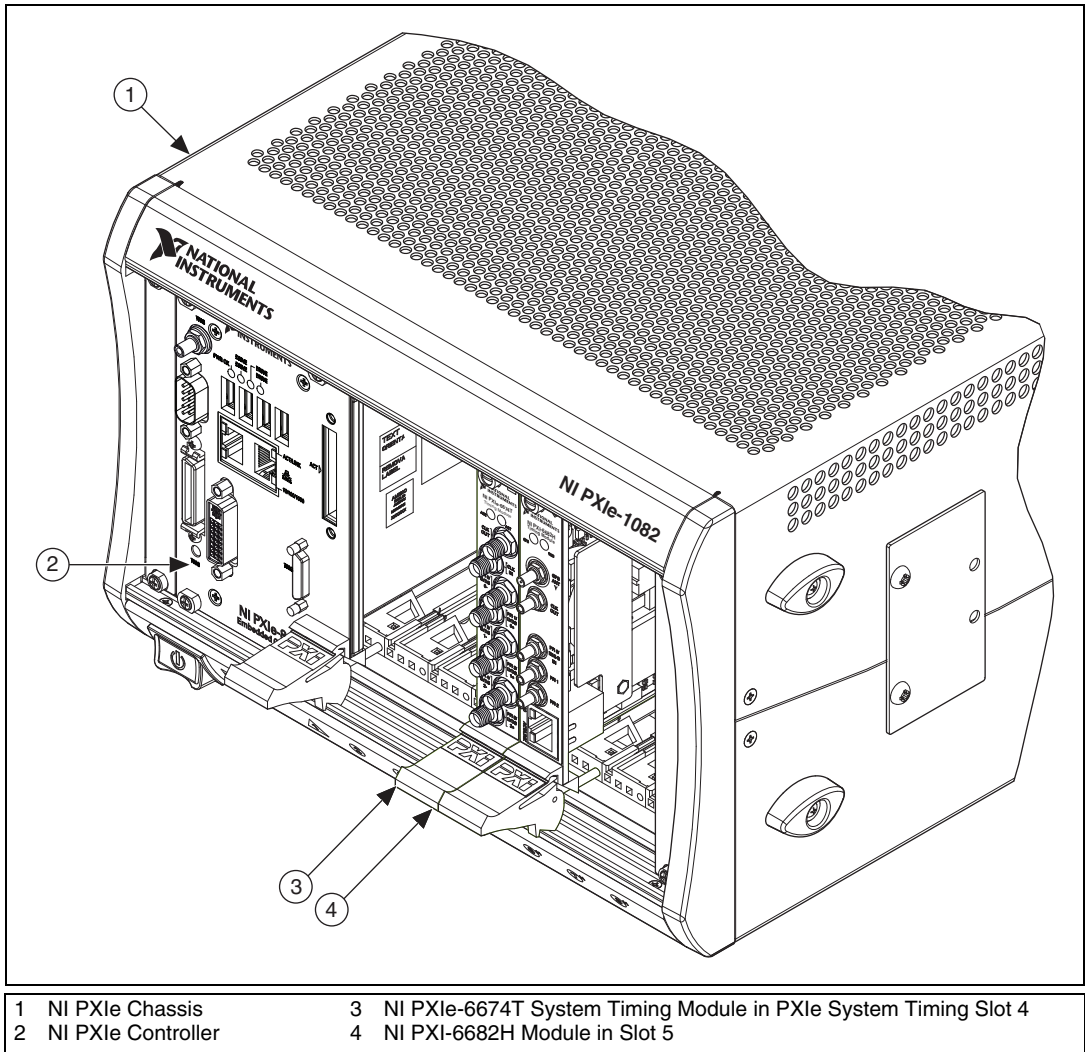

Figure 2. Hardware Requirements for the NI PXIe-6674T System Timing Module

The Multi-Device PXI_Clk10 Disciplining software uses two devices. The first device drives the 10MHz backplane clock, and the second monitors and adjusts the clock relative to an external time reference (for example, IEEE 1588, GPS, or IRIG). No external cabling is required between the modules.

NI PXI-6653

NI PXI System Timing Module

The system timing module is the NI PXI-6653. You must populate the NI PXI-6653 in the PXI star trigger slot, PXI slot 2.

NI Timing and Synchronization Module

The timing and synchronization module is the NI PXI-6682 or NI PXI-6682H. You can populate this module in any other available peripheral slot.

NI PXIe-6674T

NI PXIe System Timing Module

The system timing module is the NI PXIe-6674T. You must populate the NI PXIe-6674T in the PXIe system timing slot.

NI Timing and Synchronization Module

The timing and synchronization module is the NI PXI-6682H. You can populate this module in any other available peripheral slot.

Software Requirements

NI PXI-6653

The Multi-Device PXI_Clk10 Disciplining software requires NI-Sync 3.1 or above.

NI PXIe-6674T

The Multi-Device PXI_Clk10 Disciplining software requires NI-Sync 3.2.2 or above.

Application Software and Programming Language Support

The Multi-Device PXI_Clk10 Disciplining software supports LabVIEW 8.6.1 or above.

Installing the Software/Uninstalling the Software

There is no additional software installation. You need only to include the VI library with your program or application.

Building and Programming Applications

Configuring Your System

Hardware Configuration

Follow these steps to configure your hardware:

1. **(NI PXI-6653)** Install the NI PXI-6653 system timing module in the PXI star trigger slot of your PXI chassis.
(NI PXIe-6674T) Install the NI PXIe-6674T system timing module in the PXIe system timing slot of your PXIe chassis.



Note Some chassis (including the NI PXI-103x series) require toggling a hardware switch to enable the system timing module to override PXI_Clk10. Refer to your chassis user manual for more details.

2. Install the NI PXI-6682 or NI PXI-6682H timing and synchronization module in any other compatible chassis slot.
3. Connect your time reference to the timing and synchronization module as described in your device user manual.

No other hardware connections are required.



Note This software uses the time reference configured for the timing and synchronization module. Refer to your NI PXI-6682 or NI PXI-6682H user manual for more information.

System Design Recommendations

Minimize Starting/Stopping of PXI_Clk10 Disciplining

From startup, the PXI_Clk10 synchronization can take on the order of minutes to stabilize to the time reference. You should design your application such that PXI_Clk10 disciplining runs asynchronous to other programs that might start and stop more frequently. This minimizes the time spent letting the synchronization stabilize and lock.

Avoid Disrupting PXI_Clk10 Disciplining

While you can use the devices used for PXI_Clk10 disciplining within other applications, you should avoid resetting them or changing the configured time reference. Doing so disrupts the PXI_Clk10 disciplining process.

Interactively Using Multi-Device PXI_Clk10 Disciplining

The **Clock Disciplining App** VI is a simple, interactive way for you to use PXI_Clk10 disciplining without writing an application.

Programmatically Using Multi-Device PXI_Clk10 Disciplining

You can use the following functions for programmatic PXI_Clk10 disciplining.

API Functions

Start Clock Servo

Starts the PXI_Clk10 disciplining. Required inputs define the system timing and time-based modules to be used. **(Optional)** You can offset the system by a time reference correction.

Get Clock Servo Status

Provides synchronization status information about the PXI_Clk10 disciplining state.

Stop Clock Servo

Stops the PXI_Clk10 disciplining.

LabVIEW, National Instruments, NI, ni.com, the National Instruments corporate logo, and the Eagle logo are trademarks of National Instruments Corporation. Refer to the *Trademark Information* at ni.com/trademarks for other National Instruments trademarks. Other product and company names mentioned herein are trademarks or trade names of their respective companies. For patents covering National Instruments products/technology, refer to the appropriate location: **Help»Patents** in your software, the `patents.txt` file on your media, or the *National Instruments Patent Notice* at ni.com/patents. Refer to the *Export Compliance Information* at ni.com/legal/export-compliance for the National Instruments global trade compliance policy and how to obtain relevant HTS codes, ECCNs, and other import/export data.