

## COMPREHENSIVE SERVICES

We offer competitive repair and calibration services, as well as easily accessible documentation and free downloadable resources.

## SELL YOUR SURPLUS

We buy new, used, decommissioned, and surplus parts from every NI series. We work out the best solution to suit your individual needs.

 Sell For Cash    Get Credit    Receive a Trade-In Deal

## OBSOLETE NI HARDWARE IN STOCK & READY TO SHIP

We stock **New**, **New Surplus**, **Refurbished**, and **Reconditioned** NI Hardware.



*Bridging the gap between the manufacturer and your legacy test system.*

 1-800-915-6216

 [www.apexwaves.com](http://www.apexwaves.com)

 [sales@apexwaves.com](mailto:sales@apexwaves.com)

*All trademarks, brands, and brand names are the property of their respective owners.*

**Request a Quote**

 **CLICK HERE**

**PXI-8156**

# PXI

---

## PXI™-1000 User Manual

**Internet Support**

E-mail: [support@natinst.com](mailto:support@natinst.com)

FTP Site: [ftp.natinst.com](ftp://ftp.natinst.com)

Web Address: <http://www.natinst.com>

**Bulletin Board Support**

BBS United States: 512 794 5422

BBS United Kingdom: 01635 551422

BBS France: 01 48 65 15 59

**Fax-on-Demand Support**

512 418 1111

**Telephone Support (USA)**

Tel: 512 795 8248

Fax: 512 794 5678

**International Offices**

Australia 03 9879 5166, Austria 0662 45 79 90 0, Belgium 02 757 00 20, Brazil 011 288 3336,  
Canada (Ontario) 905 785 0085, Canada (Québec) 514 694 8521, Denmark 45 76 26 00, Finland 09 725 725 11,  
France 01 48 14 24 24, Germany 089 741 31 30, Hong Kong 2645 3186, Israel 03 6120092, Italy 02 413091,  
Japan 03 5472 2970, Korea 02 596 7456, Mexico 5 520 2635, Netherlands 0348 433466, Norway 32 84 84 00,  
Singapore 2265886, Spain 91 640 0085, Sweden 08 730 49 70, Switzerland 056 200 51 51, Taiwan 02 377 1200,  
United Kingdom 01635 523545

**National Instruments Corporate Headquarters**

6504 Bridge Point Parkway Austin, Texas 78730-5039 USA Tel: 512 794 0100

# Important Information

---

## Warranty

The PXI-1000 is warranted against defects in materials and workmanship for a period of one year from the date of shipment, as evidenced by receipts or other documentation. National Instruments will, at its option, repair or replace equipment that proves to be defective during the warranty period. This warranty includes parts and labor.

The media on which you receive National Instruments software are warranted not to fail to execute programming instructions, due to defects in materials and workmanship, for a period of 90 days from date of shipment, as evidenced by receipts or other documentation. National Instruments will, at its option, repair or replace software media that do not execute programming instructions if National Instruments receives notice of such defects during the warranty period. National Instruments does not warrant that the operation of the software shall be uninterrupted or error free.

A Return Material Authorization (RMA) number must be obtained from the factory and clearly marked on the outside of the package before any equipment will be accepted for warranty work. National Instruments will pay the shipping costs of returning to the owner parts which are covered by warranty.

National Instruments believes that the information in this manual is accurate. The document has been carefully reviewed for technical accuracy. In the event that technical or typographical errors exist, National Instruments reserves the right to make changes to subsequent editions of this document without prior notice to holders of this edition. The reader should consult National Instruments if errors are suspected. In no event shall National Instruments be liable for any damages arising out of or related to this document or the information contained in it.

EXCEPT AS SPECIFIED HEREIN, NATIONAL INSTRUMENTS MAKES NO WARRANTIES, EXPRESS OR IMPLIED, AND SPECIFICALLY DISCLAIMS ANY WARRANTY OF MERCHANTABILITY OR FITNESS FOR A PARTICULAR PURPOSE. CUSTOMER'S RIGHT TO RECOVER DAMAGES CAUSED BY FAULT OR NEGLIGENCE ON THE PART OF NATIONAL INSTRUMENTS SHALL BE LIMITED TO THE AMOUNT THEREFORE PAID BY THE CUSTOMER. NATIONAL INSTRUMENTS WILL NOT BE LIABLE FOR DAMAGES RESULTING FROM LOSS OF DATA, PROFITS, USE OF PRODUCTS, OR INCIDENTAL OR CONSEQUENTIAL DAMAGES, EVEN IF ADVISED OF THE POSSIBILITY THEREOF. This limitation of the liability of National Instruments will apply regardless of the form of action, whether in contract or tort, including negligence. Any action against National Instruments must be brought within one year after the cause of action accrues. National Instruments shall not be liable for any delay in performance due to causes beyond its reasonable control. The warranty provided herein does not cover damages, defects, malfunctions, or service failures caused by owner's failure to follow the National Instruments installation, operation, or maintenance instructions; owner's modification of the product; owner's abuse, misuse, or negligent acts; and power failure or surges, fire, flood, accident, actions of third parties, or other events outside reasonable control.

## Copyright

Under the copyright laws, this publication may not be reproduced or transmitted in any form, electronic or mechanical, including photocopying, recording, storing in an information retrieval system, or translating, in whole or in part, without the prior written consent of National Instruments Corporation.

## Trademarks

PXI™ is a trademark of National Instruments Corporation.

Product and company names listed are trademarks or trade names of their respective companies.

## WARNING REGARDING MEDICAL AND CLINICAL USE OF NATIONAL INSTRUMENTS PRODUCTS

National Instruments products are not designed with components and testing intended to ensure a level of reliability suitable for use in treatment and diagnosis of humans. Applications of National Instruments products involving medical or clinical treatment can create a potential for accidental injury caused by product failure, or by errors on the part of the user or application designer. Any use or application of National Instruments products for or involving medical or clinical treatment must be performed by properly trained and qualified medical personnel, and all traditional medical safeguards, equipment, and procedures that are appropriate in the particular situation to prevent serious injury or death should always continue to be used when National Instruments products are being used. National Instruments products are NOT intended to be a substitute for any form of established process, procedure, or equipment used to monitor or safeguard human health and safety in medical or clinical treatment.

# Compliance

---

## FCC/DOC Radio Frequency Interference Class A Compliance

This equipment generates and uses radio frequency energy and, if not installed and used in strict accordance with the instructions in this manual, may cause interference to radio and television reception. Classification requirements are the same for the Federal Communications Commission (FCC) and the Canadian Department of Communications (DOC). This equipment has been tested and found to comply with the following two regulatory agencies:

### Federal Communications Commission

This equipment has been tested and found to comply with the limits for a Class A digital device, pursuant to part 15 of the FCC Rules. These limits are designed to provide reasonable protection against harmful interference when the equipment is operated in a commercial environment. This equipment generates, uses, and can radiate radio frequency energy and, if not installed and used in accordance with the instruction manual, may cause harmful interference to radio communications. Operation of this equipment in a residential area is likely to cause harmful interference in which case the user will be required to correct the interference at his own expense.

**Notices to User:** *Changes or modifications not expressly approved by National Instruments could void the user's authority to operate the equipment under the FCC Rules.*

*This device complies with the FCC rules only if used with shielded interface cables of suitable quality and construction. National Instruments used such cables to test this device and provides them for sale to the user. The use of inferior or nonshielded interface cables could void the user's authority to operate the equipment under the FCC rules.*

If necessary, consult National Instruments or an experienced radio/television technician for additional suggestions. The following booklet prepared by the FCC may also be helpful: *Interference to Home Electronic Entertainment Equipment Handbook*. This booklet is available from the U.S. Government Printing Office, Washington, DC 20402.

### Canadian Department of Communications

This Class A digital apparatus meets all requirements of the Canadian Interference-Causing Equipment Regulations.

Cet appareil numérique de la classe A respecte toutes les exigences du Règlement sur le matériel brouilleur du Canada.

# For Your Safety

---



**Caution** *Before undertaking any troubleshooting, maintenance, or exploratory procedure, read carefully the WARNING and CAUTION notices.*

This equipment contains voltage hazardous to human life and safety, and is capable of inflicting personal injury.

- **Mainframe Grounding**—The PXI-1000 mainframe requires a connection from the premise wire safety ground to the PXI-1000 chassis ground. The earth safety ground must be connected during use of this equipment to minimize shock hazards. Refer to the [Connecting Safety Ground](#) section of Chapter 2, *Installation and Configuration*, for instructions on connecting safety ground.
- **Live Circuits**—Operating personnel and service personnel must not remove protective covers when operating or servicing the PXI-1000. Adjustments and service to internal components must be undertaken by qualified service technicians. During service of this product, the mains connector to the premise wiring must be disconnected. Dangerous voltages may be present under certain conditions; use extreme caution.
- **Explosive Atmosphere**—Do not operate the mainframe in conditions where flammable gases are present. Under such conditions this equipment is unsafe and may ignite the gases or gas fumes.
- **Part Replacement**—Only service this equipment with parts that are exact replacements, both electrically and mechanically. Contact National Instruments for replacement part information. Installation of parts with those that are not direct replacements may cause harm to personnel operating the mainframe. Furthermore, damage or fire may occur if replacement parts are unsuitable.
- **Modification**—Do not modify any part of the mainframe from its original condition. Unsuitable modifications may result in safety hazards.

# Contents

---

## About This Manual

Organization of This Manual .....	xi
Conventions Used in This Manual .....	xi
Related Documentation .....	xii
Customer Communication .....	xii

## Chapter 1

### Getting Started

Unpacking .....	1-1
What You Need to Get Started .....	1-1
Optional Equipment .....	1-2
Key Features .....	1-2
PXI-1000 Backplane Overview .....	1-3
Interoperability with CompactPCI .....	1-3
System Controller Slot .....	1-5
Star Trigger Slot .....	1-5
Peripheral Slots .....	1-5
Local Bus .....	1-6
Trigger Bus .....	1-6
System Reference Clock .....	1-7

## Chapter 2

### Installation and Configuration

Site Considerations .....	2-1
Rack Mounting .....	2-2
Setting Fan Speed .....	2-2
Connecting Safety Ground .....	2-3
Connecting to AC Mains Power and Testing Power up .....	2-3
Remote Power Monitoring and Inhibiting Interface .....	2-5
Installing PXI Modules .....	2-6
Installing Filler Panels .....	2-7
Using the Chassis Initialization File .....	2-7

## Chapter 3

### Maintenance

Service Interval .....	3-1
Preparation .....	3-1

Cleaning.....	3-1
Interior Cleaning .....	3-2
Exterior Cleaning .....	3-2
Cleaning the Fan Filters.....	3-2
Resetting the AC Mains Circuit Breaker.....	3-3
Troubleshooting the PXI-1000.....	3-4

## **Appendix A Specifications**

## **Appendix B Pinouts**

## **Appendix C Customer Communication**

## **Glossary**

## **Index**

## **Figures**

Figure 1-1.	Front View of the PXI-1000 Mainframe .....	1-4
Figure 1-2.	Rear View of the PXI-1000 Mainframe.....	1-5
Figure 1-3.	PXI Local Bus and Star Trigger Routing.....	1-6
Figure 2-1.	PXI-1000 Mainframe Airflow Side View.....	2-2
Figure 2-2.	Installing PXI or CompactPCI Modules .....	2-6
Figure 2-3.	Injector/Ejector Handle Position during Module Insertion.....	2-7
Figure A-1.	PXI-1000 Dimensions.....	A-7

## **Tables**

Table 1-1.	Power Cables .....	1-1
Table 2-1.	Power Supply Voltages at Power Monitoring Connector (DB-9) .....	2-4
Table 2-2.	DB-9 Connector Pinout.....	2-5
Table 3-1.	Troubleshooting .....	3-4



Table A-1.	AC Input Specifications .....	A-1
Table A-2.	DC Output Specifications.....	A-2
Table A-3.	Cooling Specifications .....	A-3
Table A-4.	Safety Specifications .....	A-3
Table A-5.	Environmental Specifications.....	A-4
Table A-6.	Backplane Specifications .....	A-5
Table A-7.	Mechanical Specifications.....	A-6
Table B-1.	P1 (J1) Connector Pinout for the System Controller Slot .....	B-2
Table B-2.	P2 (J2) Connector Pinout for the System Controller Slot .....	B-3
Table B-3.	P1 (J1) Connector Pinout for the Star Trigger Slot .....	B-4
Table B-4.	P2 (J2) Connector Pinout for the Star Trigger Slot .....	B-5
Table B-5.	P1 (J1) Connector Pinout for the Peripheral Slot .....	B-6
Table B-6.	P2 (J2) Connector Pinout for the Peripheral Slot .....	B-7

# About This Manual

---

The *PXI-1000 User Manual* describes the features of the PXI-1000 mainframe and contains information about configuring the mainframe, installing the modules, and operating and using the PXI-1000.

## Organization of This Manual

---

This manual is organized as follows:

- Chapter 1, *Getting Started*, describes the key features of the PXI-1000, lists the contents of your kit, and lists optional equipment you can order from National Instruments.
- Chapter 2, *Installation and Configuration*, describes how to prepare and operate your PXI-1000 mainframe.
- Chapter 3, *Maintenance*, describes basic maintenance procedures you can perform on the PXI-1000 mainframe.
- Appendix A, *Specifications*, contains complete specifications for the PXI-1000 mainframe.
- Appendix B, *Pinouts*, describes the P1 and P2 connector pinouts for the PXI-1000 backplane.
- Appendix C, *Customer Communication*, contains forms you can use to request help from National Instruments or to comment on our products and manuals.
- The *Glossary* lists abbreviations, acronyms, metric prefixes, mnemonics, symbols, and terms.
- The *Index* contains an alphabetical list of key terms and topics used in this manual, including the page where you can find each one.

## Conventions Used in This Manual

---

The following conventions are used in this manual:



This icon to the left of bold italicized text denotes a note, which alerts you to important information.



This icon to the left of bold italicized text denotes a caution, which advises you of precautions to take to avoid injury, data loss, or a system crash.



This icon to the left of bold italicized text denotes a warning, which advises you of precautions to take to avoid being electrically shocked.

***bold italic***

Bold italic text denotes a note, caution, or warning.

*italic*

Italic text denotes emphasis, a cross reference, or an introduction to a key concept. This font also denotes text from which you supply the appropriate word or value, as in Windows 3.x.

monospace

Text in this font denotes text or characters that are to be literally enter from the keyboard, sections of code, programming examples, and syntax examples. This font is also used for the proper names of disk drives, paths, directories, device names, functions, variables, filenames, and extensions.

## Related Documentation

---

The following documents contain information that you may find helpful as you read this manual:

- *Compact PCI Specification PICMG 2.0 R2.1*
- *PXI Specification Revision 1.0*
- IEEE 1101.1-1991, *IEEE Standard for Mechanical Core Specifications for Microcomputers Using IEC 603-2 Connectors*
- IEEE 1101.10 and P1101.11, *IEEE Standard for Additional Mechanical Specifications for Microcomputers Using IEEE 1101.1 Equipment Practice*

## Customer Communication

---

National Instruments wants to receive your comments on our products and manuals. We are interested in the applications you develop with our products, and we want to help if you have problems with them. To make it easy for you to contact us, this manual contains comment and configuration forms for you to complete. These forms are in Appendix C, [Customer Communication](#), at the end of this manual.

---

# Getting Started

This chapter describes the key features of the PXI-1000, lists the contents of your kit, and lists optional equipment you can order from National Instruments.

## Unpacking

---

Carefully inspect the shipping container and the mainframe for damage. Check for visible damage to the metal work. Check to make sure all handles, hardware, and switches are undamaged. Inspect the inner chassis for any possible damage, debris, or detached components. If damage appears to have been caused in shipment, file a claim with the carrier. Retain the packing material for possible inspection and/or reshipment.

## What You Need to Get Started

---

The PXI-1000 kit contains the following items:

- PXI-1000 mainframe
- Filler panels
- Power cable (see Table 1-1)
- PXI-1000 User Manual*
- Floppy disk with Chassis Initialization file, `chassis.ini`

**Table 1-1.** Power Cables

Power Cable	Reference Standards
Standard 120 V (USA)	ANSI C73.11/NEMA 5-15-P/IEC83
Switzerland 220 V	SEV
Australia 240 V	AS C112

**Table 1-1.** Power Cables (Continued)

<b>Power Cable</b>	<b>Reference Standards</b>
Universal Euro 240 V	CEE (7), II, IV, VII IEC83
North America 240 V	ANSI C73.20/NEMA 5-15-P/IEC83
United Kingdom 240 V	BS 1363/IEC83

If you are missing any of the above items or if you have the incorrect power cord, contact National Instruments.

## Optional Equipment

---

An optional rack-mount kit is available from National Instruments. You can use this kit to install the PXI-1000 mainframe into a standard 19 in. (482 mm) instrument cabinet. Contact National Instruments to order the PXI-1000 rack-mount kit.

## Key Features

---

The PXI-1000 combines a high-performance 8-slot PXI backplane with a high-output power supply and a structural design that has been optimized for maximum usability in a wide range of applications. The mainframe's modular design ensures the highest level of maintainability resulting in a very low mean time to repair (MTTR). The PXI-1000 fully complies with the PXI Specification, Revision 1.0, offering advanced timing and synchronization features.

The key features of the PXI-1000 include:

- PXI and CompactPCI (PICMG 2.0 R 2.1) module compatibility
- Compact 3U-sized, 8-slot chassis
- 300 W of usable power
- Universal AC input: auto-voltage and auto-frequency ranging
- Over-current protection via push-reset circuit breaker (no loose fuses to replace)
- Removable modular power supply with MTBF of 90,000 hours
- Remote power status and inhibit via a rear panel connector
- On/Off (Standby) switch located on the front panel for easy access

- Selectable fan speed for maximum cooling or quiet operation
- Carrying handle for portability
- Tilt feet for bench-top applications

## **PXI-1000 Backplane Overview**

---

### **Interoperability with CompactPCI**

The PXI-1000 backplane is interoperable with PXI-compatible products and standard CompactPCI products. This is an important feature, as many PXI-compatible systems may not require components that do not implement PXI-specific features. For example, you may want to use a standard CompactPCI network interface card in a PXI chassis.

The signals on the P1 connector of the backplane meet the requirements of the CompactPCI specification for both the peripheral and system modules.

The PXI-specific signals are located on P2 and are only found on the signals that are reserved or not used in the CompactPCI 64-bit specification. Therefore, all modules that meet the requirements of the CompactPCI 64-bit specification will function in the PXI-1000.

Figures 1-1 and 1-2 show some of the key features and components of the PXI-1000 mainframe. Figure 1-1 shows the front view of the PXI-1000 and Figure 1-2 shows the rear view.

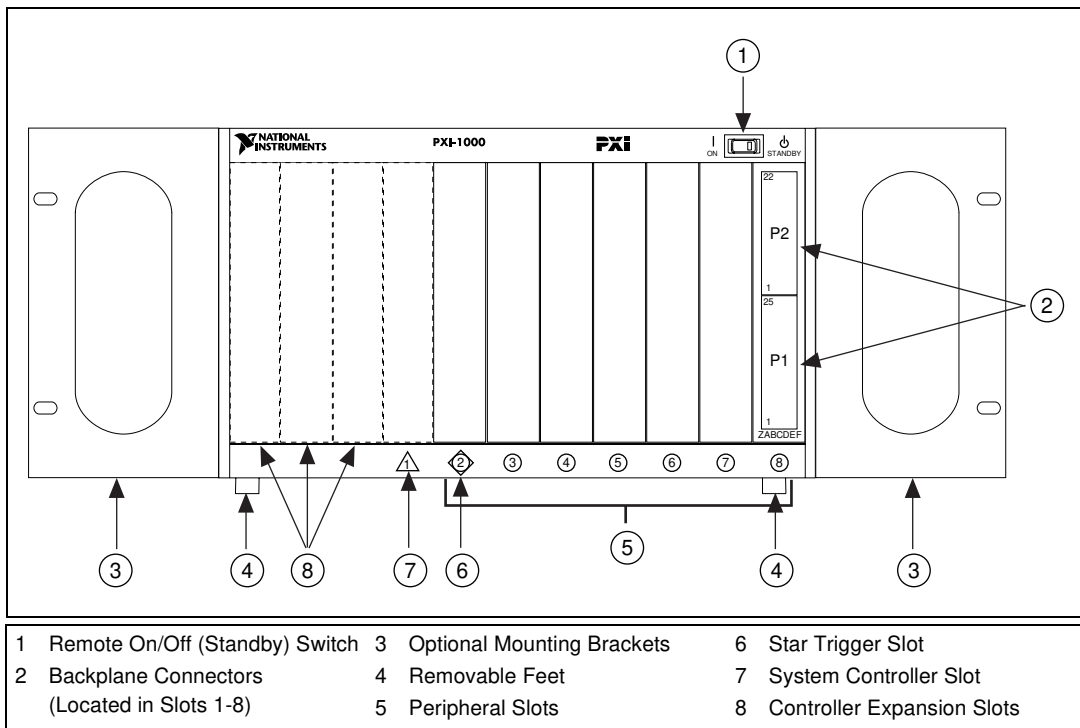

**Figure 1-1.** Front View of the PXI-1000 Mainframe

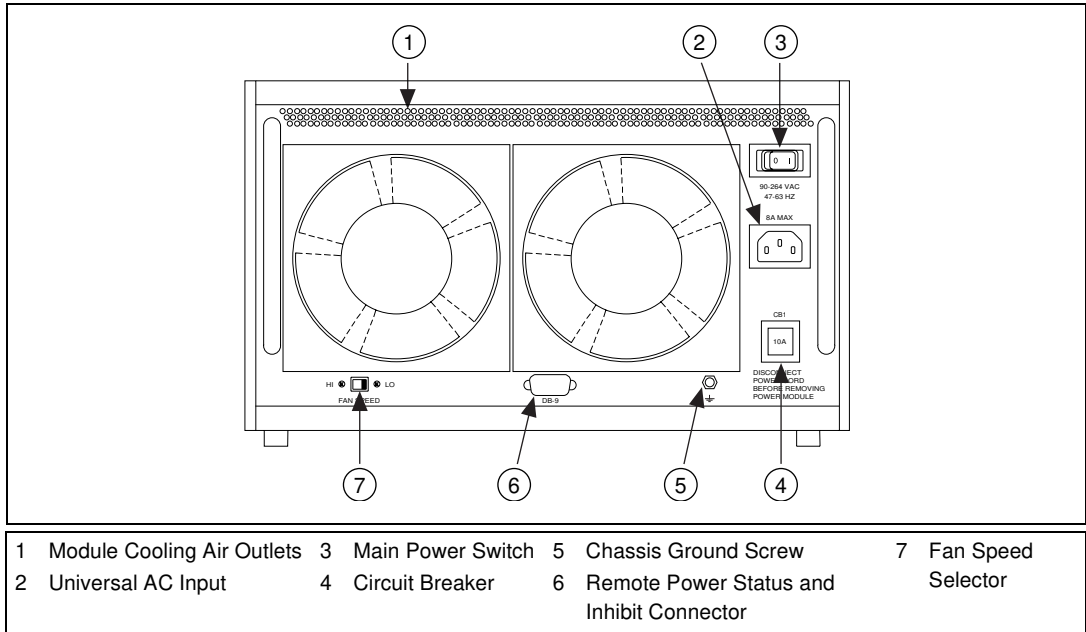

**Figure 1-2.** Rear View of the PXI-1000 Mainframe

## System Controller Slot

The System Controller slot is located in Slot 1 of the chassis as defined by the PXI specification. It has three controller expansion slots, which are used for system controller modules that are wider than one slot. As defined in the PXI specification, these slots allow the controller to expand to the left to prevent the controller from using up peripheral slots.

## Star Trigger Slot

The Star Trigger (ST) slot is located at Slot 2. This slot has a dedicated trigger line between each peripheral slot (see Figure 1-3). This slot is intended for modules with ST functionality that can provide individual triggers to all other peripherals. However, if you do not require advanced trigger functionality, you can install any standard peripheral module into this slot.

## Peripheral Slots

There are seven peripheral slots including the Star Trigger controller slot.



## Local Bus

The PXI backplane's local bus is a daisy-chained bus that connects each peripheral slot with its adjacent peripheral slots to the left and right, as shown in Figure 1-3.

For example, a given peripheral slot's right local bus connects to the adjacent slot's left local bus and so on. Each local bus is 13 lines wide and can pass analog signals between cards or provide a high-speed side-band communication path that does not affect the PXI bandwidth.

Local Bus signals may range from high-speed TTL signals to analog signals as high as 42 V. Initialization software keys adjacent boards to prohibit the use of incompatible boards. This software uses the configuration information specific to each peripheral board to evaluate compatibility. This method is a flexible way to define local bus functionality that is not limited by hardware keying.

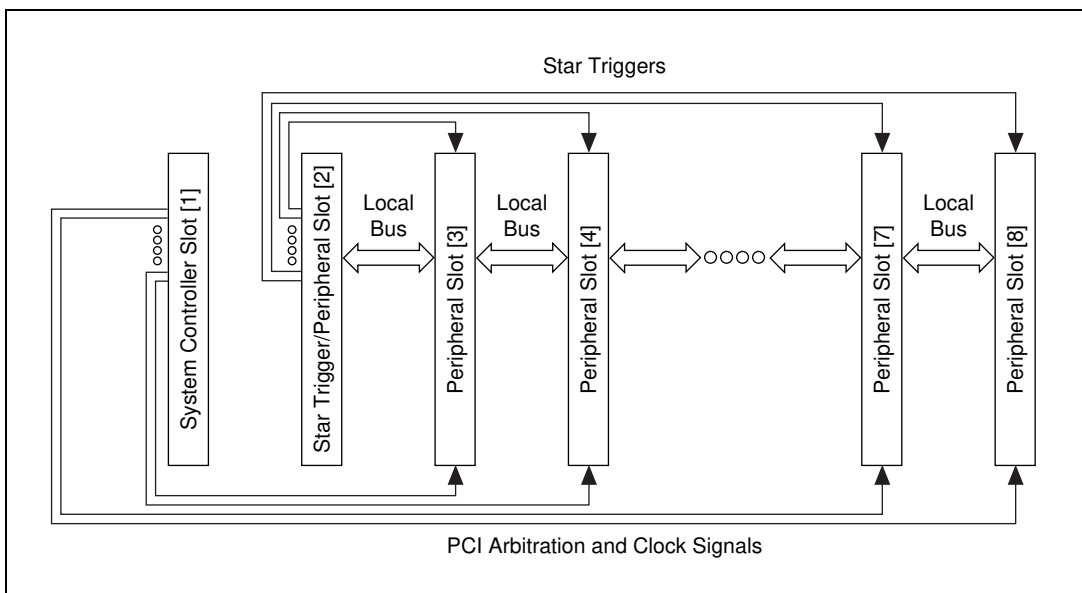

**Figure 1-3.** PXI Local Bus and Star Trigger Routing

## Trigger Bus

The eight PXI trigger lines are bused to each slot. You can use the trigger lines in a variety of ways. For example, you can use triggers to synchronize the operation of several different PXI peripheral modules. In other applications, one module can control carefully timed sequences of

operations performed on other modules in the system. Modules can pass triggers to one another, allowing precisely timed responses to asynchronous external events the system is monitoring or controlling.

## System Reference Clock

The PXI-1000 supplies the PXI 10 MHz system clock signal (PXI\_CLK10) independently to each peripheral slot. An independent buffer (having a source impedance matched to the backplane and a skew of less than 1 ns between slots) drives the clock signal to each peripheral slot. You can use this common reference clock signal to synchronize multiple modules in a measurement or control system. You can drive PXI\_CLK10 from an external source through the PXI\_CLK10\_IN pin on the P2 connector of the Star Trigger Slot. (See Table B-1, *P1 (J1) Connector Pinout for the System Controller Slot*, in Appendix B, *Pinouts*.) Sourcing an external clock on this pin automatically disables the backplane's 10 MHz source.

---

# Installation and Configuration

This chapter describes how to prepare and operate your PXI-1000 mainframe.

Before connecting the mainframe to a power source, read this chapter and the *For Your Safety* section located at the beginning of this manual.

## Site Considerations

---

The PXI-1000 is designed to operate on a bench or in an instrument rack. Determine how you want to use your PXI-1000 and follow the appropriate installation instructions.

Apertures in the rear and along both sides of the mainframe facilitate power supply and module cooling. Air enters through filters and fan inlets located in the lower rear of the mainframe and exits through the upper sections on both sides and through the rear, as shown in Figure 2-1. Place your PXI-1000 on a bench top or in an instrument rack so that the fans (air inlets) and the air outlet apertures along both sides of the mainframe have adequate ventilation. Keep other equipment a minimum of 3.0 in. (76.2 mm) away from the air inlets and outlets.

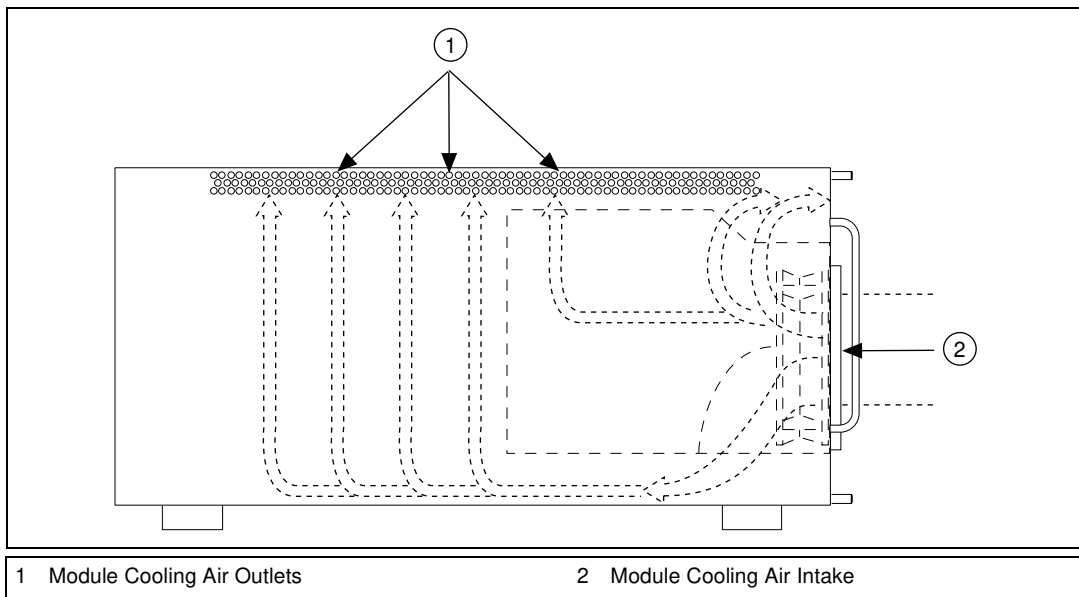

**Figure 2-1.** PXI-1000 Mainframe Airflow Side View

Install your mainframe so that you can easily access the rear panel. This simplifies the replacement of the air filters or power supply/fan assembly, if necessary.

## Rack Mounting

Rack-mount applications require the optional rack-mount kit available from National Instruments. Refer to the instructions supplied with the rack-mount kit to install your PXI-1000 in an instrument rack.



**Note**

*You may wish to remove the feet from your PXI-1000 when rack mounting. To do so, remove the two screws holding the feet in place.*

## Setting Fan Speed

The fan speed selector switch is located on the rear panel of the PXI-1000. Refer to Figure 1-2, *Rear View of the PXI-1000 Mainframe*, for a diagram of the fan speed selector. Select HI for maximum cooling effectiveness (recommended) or LO for more quiet operation.

## Connecting Safety Ground

---



**Warning** *The PXI-1000 chassis is designed with a three-position NEMA 15-5 style plug that connects the ground line to the chassis ground. To minimize shock hazard, make sure your electrical power outlet has an appropriate earth safety ground that is connected whenever you power up the chassis.*

If your power outlet does not have an appropriate ground connection, you must connect the premise wire safety ground to the chassis grounding screw located on the rear panel. Refer to Figure 1-2, *Rear View of the PXI-1000 Mainframe*, for a diagram of the chassis grounding screw. To connect the safety ground, complete the following steps:

1. Connect a 16 AWG (1.3 mm) wire to the chassis grounding screw using a toothed grounding lug. The wire must have green insulation with a yellow stripe or must be non-insulated (bare).
2. Attach the opposite end of the wire to permanent earth ground using toothed washers or a toothed lug.

## Connecting to AC Mains Power and Testing Power up

---



**Caution** *Make sure the main power switch located on the rear panel of the PXI-1000 is in the Off position (0). Refer to Figure 1-2, *Rear View of the PXI-1000 Mainframe*, for a diagram of the main power switch.*

*Do not install modules prior to performing the first power-on test.*

The power supply is universal, which means the mainframe can connect to all standard worldwide input voltages. Refer to Chapter 1, *Getting Started*, for power cord specifications. Attach input power through the rear AC inlet using the appropriate line cord supplied. Refer to Figure 1-2, *Rear View of the PXI-1000 Mainframe*, for a diagram of the IEC 320 inlet.

Push the main power switch to the On (1) position. Then push the remote power switch to the On position (if not already on). Observe that all fans become operational. Note that the main power switch (rear panel) enables the power module to receive AC power. The remote front panel standby switch allows the power module to provide power to the PXI backplane (if the rear main power switch is on). For this reason, you can leave the main power switch on and use the remote On/Off (Standby) switch on the front to power up and power down the backplane.



**Caution** *When connecting digital voltmeter probes to the rear D-sub connector, be careful not to short the probe leads together. Doing so could damage the power supply.*

You can use a digital voltmeter to ensure all voltage levels in your PXI-1000 are within the allowable limits. Referring to Table 2-1, connect one lead of the voltmeter to a supply pin on the remote power monitoring connector (9-pin D-sub) located on the rear panel. Refer to Table 2-2 for a pinout diagram of the remote power monitoring connector. Connect the reference lead of the voltmeter to one of the ground pins. Compare each voltage reading to the values listed in Table 2-1.



**Note** *Use the rear panel D-sub connector to check voltages only. Do not use the connector to supply power to external devices.*

**Table 2-1.** Power Supply Voltages at Power Monitoring Connector (DB-9)

Pin	Supply	Acceptable Voltage Range
2	+5 V	4.75 to 5.25 V
4	+3.3 V	3.135 to 3.465 V
6	+12 V	11.4 to 12.6 V
8	-12 V	-12.6 to -11.4 V
1, 9	Logic Ground	N/A

If the voltages fall within the specified ranges, the mainframe complies with the CompactPCI voltage limit specifications. Note that the rear panel D-sub connector is to be used to check voltages only. Do not use these voltages to supply power to external devices.



**Note** *If the fans or power unit fail to function properly, refer to the [Troubleshooting the PXI-1000](#) section of Chapter 3, [Maintenance](#).*

# Remote Power Monitoring and Inhibiting Interface

The PXI-1000 mainframe supports remote power monitoring and inhibiting via a 9-pin D-sub connector located on the rear panel. Table 2-2 shows the pinout of the DB-9 connector.

**Table 2-2.** DB-9 Connector Pinout

DB-9 Pin	Signal
1	Logic Ground
2	+5 V
3	Reserved
4	+3.3 V
5	Inhibit*
6	+12 V
7	Reserved
8	-12 V
9	Logic Ground

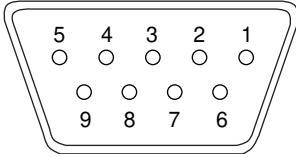
You can use the Inhibit signal (active low) to turn off the power supply outputs. To use this feature, connect the Inhibit pin (pin 5) to a Logic Ground pin (pin 1 or 9). Make sure both the rear main power switch and the front (standby) switch are in the ON position. As long as Inhibit is pulled down, the power supply inhibits its DC outputs. DC output resumes when Inhibit is no longer connected to ground. Note that the power (standby) switch, located on the front of the chassis, uses this inhibiting feature. For remote reset, connect a momentary switch between pin 5 and pin 1 (or pin 9).

# Installing PXI Modules



**Caution** Turn off the mainframe power before installing CompactPCI or PXI modules.

Install a module into a mainframe slot by first placing the module's card edges into the front module guides (top and bottom), as shown in Figure 2-2. Slide the module to the rear of the mainframe (making sure that the injector/ejector handle is pushed down as shown in Figure 2-3). When you begin to feel resistance, push up on the injector/ejector handle to inject the card into the frame. Secure the module's front panel to the mainframe using the module's front-panel mounting screws.

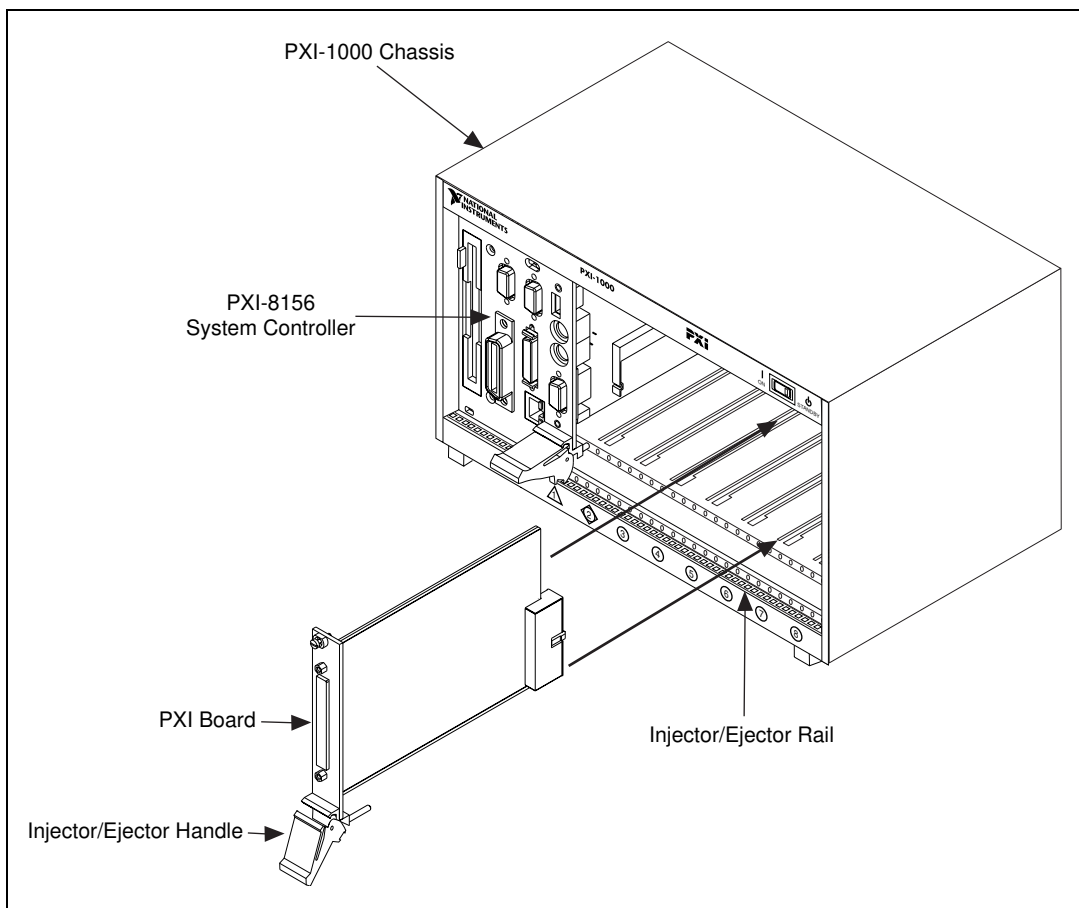

**Figure 2-2.** Installing PXI or CompactPCI Modules



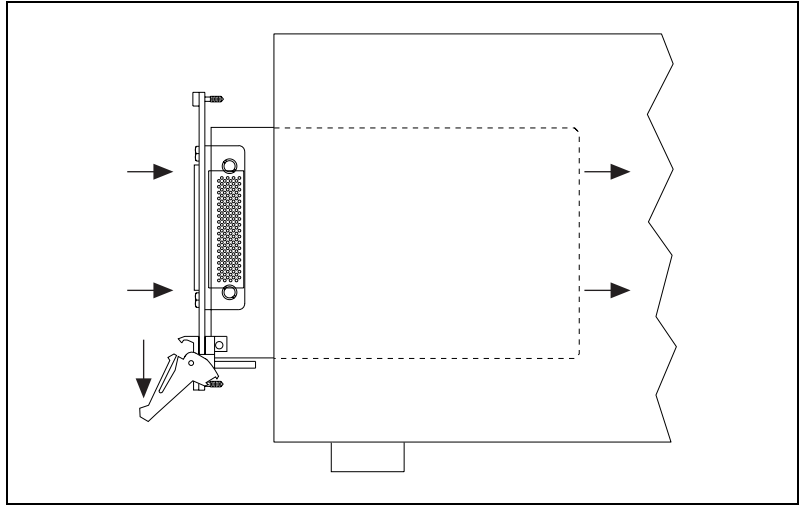

**Figure 2-3.** Injector/Ejector Handle Position during Module Insertion

## Installing Filler Panels

---

To optimize module cooling performance, install filler panels into unused or empty slots. Secure with the captive mounting screws.

## Using the Chassis Initialization File

---

To assist system integrators, the PXI specification requires manufacturers of PXI chassis and system modules to document the capabilities of their products. The minimum documentation requirements are contained in .ini files, which consist of ASCII text. The system integrator can read the .ini file, and configuration utilities and device drivers can also use this file. The PXI-1000 chassis initialization file, `chassis.ini`, is included on the diskette for your PXI-1000.

---

# Maintenance

This chapter describes basic maintenance procedures you can perform on the PXI-1000 mainframe.

## Service Interval

---

Clean the mainframe fan filters at a maximum interval of six months. Depending upon the amount of use and ambient dust levels in the operating environment, the filters may require more frequent cleaning.

Clean dust from the mainframe exterior (and interior) as needed, based on the operating environment. Periodic cleaning increases reliability.

## Preparation

---

The information in this section is designed for use by qualified service personnel. Read the *For Your Safety* section at the beginning of this manual before attempting any procedures in this chapter.



**Caution** *Many components within the mainframe are susceptible to static discharge damage. Service the mainframe only in a static-free environment. Observe standard handling precautions for static-sensitive devices while servicing the mainframe. Always wear a grounded wrist strap, or equivalent, while servicing the mainframe.*

## Cleaning

---

Cleaning procedures consist of exterior and interior cleaning of the mainframe and cleaning the fan filters. Refer to your module user documentation for information on cleaning the individual CompactPCI or PXI modules.



**Caution** *Always power-off the mainframe (using the main power switch on the rear of the mainframe) and disconnect the power cord before cleaning or servicing the mainframe.*

## Interior Cleaning

Use a dry, low-velocity stream of air to clean the interior of the mainframe. Use a soft-bristle brush for cleaning around components. If you must use a liquid for minor interior cleaning, use a 75% isopropyl alcohol solution and rinse with deionized water.

## Exterior Cleaning

Clean the exterior surfaces of the mainframe with a dry lint-free cloth or a soft-bristle brush. If any dirt remains, wipe with a cloth moistened in a mild soap solution. Remove any soap residue by wiping with a cloth moistened with clear water. Do not use abrasive compounds on any part of the mainframe.



**Cautions** *Avoid getting moisture inside the mainframe during exterior cleaning. Use just enough moisture to dampen the cloth.*

*Do not wash the front- or rear-panel connectors or switches. Cover these components while cleaning the mainframe.*

*Do not use chemical cleaning agents; they may damage the mainframe. Avoid chemicals that contain benzene, toluene, xylene, acetone, or similar solvents.*

## Cleaning the Fan Filters

---

You can easily remove the mainframe cooling filters from the rear of the mainframe by removing the plastic housing attached to each fan.

Clean the fan filters by washing them in a mild soap solution and then vacuuming or blowing air through them. Rinse the filters with water and allow them to dry before reinstalling them on the mainframe.

## Resetting the AC Mains Circuit Breaker

---

If your PXI-1000 encounters an over-current condition, the circuit breaker located on the rear panel will trip to prevent damage to the mainframe. Complete the following steps to reset the circuit breaker:

1. Turn the front panel (remote) power switch to the Standby position.
2. Turn off the rear main power switch.
3. Depress the circuit breaker to reset it.
4. Turn on the rear main power switch.
5. Turn the front panel (remote) power switch to the On position.

If the circuit breaker trips again, complete the following steps:

1. Turn the front panel power switch to the Standby position.
2. Turn off the rear main power switch.
3. Disconnect the mainframe from the AC mains power source.
4. Remove all modules from the mainframe.
5. Complete the test procedure described in the [Connecting to AC Mains Power and Testing Power up](#) section in Chapter 2, [Installation and Configuration](#).
6. If any voltages are outside the acceptable limits, contact National Instruments.
7. If all voltages are within the acceptable limits, verify that your PXI-1000 can meet the power requirements of your CompactPCI or PXI modules. Overloading the chassis can cause the breaker to trip. Refer to Appendix A, [Specifications](#).
8. The over-current condition that caused the circuit breaker to trip may be due to a faulty CompactPCI or PXI module. Refer to the documentation that was supplied with the modules for troubleshooting your modules.

## Troubleshooting the PXI-1000

---

Refer to Table 3-1 to troubleshoot the PXI-1000 mainframe. The table lists possible causes for power failure and recommends ways to correct the problem.

**Table 3-1.** Troubleshooting

Possible Cause	What to Do
PXI-1000 mainframe is not connected to power source.	Make sure that the PXI-1000 is connected to a live electrical outlet. Try operating another piece of equipment from this outlet.
Power switches are not switched on.	Set the rear (main) power switch and the front (standby) power switch to the On position.
Remote inhibiting input on the rear panel of the mainframe is active.	Deactivate your system's remote inhibiting control.
Circuit breaker is tripped.	Reset the circuit breaker. Refer to the <i>Resetting the AC Mains Circuit Breaker</i> section in this chapter.
Power supply has failed.	Contact National Instruments.

# Specifications

This appendix contains complete specifications for the PXI-1000 mainframe.

## Electrical

**Table A-1.** AC Input Specifications

Characteristic	Description
Input Voltage Range	90–264 VAC
Input Frequency Range	47 to 63 Hz
Over-Current Protection	10 A circuit breaker
Operating Current	8 A
Line Regulation	$\pm 0.5\%$ over operating line range, all outputs
Efficiency	80% typical
Transient Response	Output maximum excursion of $\pm 5\%$ for 25% load step. Recovery less than 500 $\mu\text{s}$ .
Power Disconnect	The rear main power switch supplies AC power to power module. The front (standby) power switch causes the power module to supply DC power to the CompactPCI/PXI backplane whenever the main power switch (rear panel) is in the On (1) position. The rear-panel D-sub connector facilitates remote inhibiting operation. Both the rear main power switch and the front (standby) switch must be in the On position prior to use of remote inhibit. The power cord provides main power disconnect.

**Table A-2.** DC Output Specifications

<b>Characteristic</b>	<b>Description</b>										
Maximum Usable Power	300 W										
DC Current Capacity ( $I_{MP}$ )	<table> <thead> <tr> <th>Voltage</th> <th><math>I_{MP}</math> (Steady-State Current)</th> </tr> </thead> <tbody> <tr> <td>+3.3 V</td> <td>40 A</td> </tr> <tr> <td>+12 V</td> <td>4 A</td> </tr> <tr> <td>+5 V</td> <td>20 A</td> </tr> <tr> <td>-12 V</td> <td>1 A</td> </tr> </tbody> </table>	Voltage	$I_{MP}$ (Steady-State Current)	+3.3 V	40 A	+12 V	4 A	+5 V	20 A	-12 V	1 A
Voltage	$I_{MP}$ (Steady-State Current)										
+3.3 V	40 A										
+12 V	4 A										
+5 V	20 A										
-12 V	1 A										
Load Regulation	<p>1% for 10% to 100% load changes, all outputs</p> <p>10% min. load required on V1 (+3.3 V) for max. load regulation on outputs V2 (+5 V), V3 (+12 V), and V4 (-12 V).</p>										
Maximum Ripple and Noise	<p>1% ripple, 1% noise, or 100 mV, whichever is greater</p> <p>20 MHz bandwidth</p>										
Over-Current Protection	All outputs protected from short circuit and overload, automatic recovery										
Over-Voltage Protection	<p>3.3 V clamps at 20% to 30% above output voltage</p> <p>5 V, +12 V, and -12 V clamps at 10% to 20% above output voltage</p>										
Power Supply Unit MTBF	90,000+ hr										
Power Supply/Fan Unit MTTR	Replacement in under 5 minutes										

# Cooling

---

**Table A-3.** Cooling Specifications

Characteristic	Description
Per Slot Cooling Capacity	Slot cooling capacity in worst-case slot is 20 W with fan speed set to HI
Module Cooling System	Forced air circulation (positive pressurization) via two 60 cfm fans with HI/LO speed selector
Slot Airflow Direction	P1 to P2, bottom of module to top of module
Module Cooling Intake	Bottom rear of mainframe
Module Cooling Exhaust	Along both sides of mainframe
Power Supply Cooling System	Forced air circulation via integrated fan
Power Supply Cooling Intake	Rear of mainframe
Power Supply Cooling Exhaust	Along both sides of mainframe rear and upper rear panel
Module Cooling Fan MTBF	40,000+ hr
Power Supply/Fan Unit	Replacement in under 5 minutes

# Safety

---

**Table A-4.** Safety Specifications

Characteristic	Description
Safety Characteristics	UL 3111-1, IEC 1010-1, CSA 22.2 No. 1010.1 Installation Category II Pollution Degree 2 Safety Class 1



# Environmental

**Table A-5.** Environmental Specifications

Characteristic	Description
Operating Temperature	0° to 50° C (fan in LO position) 0° to 55° C (fan in HI position)
Storage Temperature	-20° to 70° C
Operating Relative Humidity	Maximum 80% for temperatures up to 31° C, decreasing linearly to 50% at 40° C
Functional Shock (Operating)	MIL-T-28800E CLASS 3, Half-Sine Shock Pulse, 11 ms duration, 30 g peak
Operating Location	Indoor use
Random Vibration (Operational)*	5 to 500 Hz, 0.31 g <sub>RMS</sub>
Random Vibration (Non-Operational)*	10 to 500 Hz, 2.46 g <sub>RMS</sub>
EMC Emissions	FCC Class A compliant and EN 55011 Group 1 Class A Compliant
EMC Immunity	Refer to DOC supplied with chassis for compliance to relevant directives.
Altitude	2 km (1.24 mi)
* Random vibration profiles were developed in accordance with MIL-T-28800E CLASS 3 and MIL-STD-810E Method 514 Test levels exceed those recommended in MIL-STD-810E for Category 1 (Basic Transportation), Figures 514.4-1 through 514.4-3.	

# Backplane

---

**Table A-6.** Backplane Specifications

Characteristic	Description
Size	3U-sized; one system slot (with three system expansion slots) and seven peripheral slots. Compliant with IEEE 1101.10 mechanical packaging. PXI Specification Revision 1.0 compliant. Accepts both PXI and CompactPCI (PICMG 2.0 R2.1) 3U modules.
Backplane Bare-Board Material	UL 94 V-0 recognized (File No. E 116551)
Backplane Connectors	Conform to IEC 917 and IEC 1076-4-101, and are UL 94 V-0 rated

# Mechanical

---

**Table A-7.** Mechanical Specifications

Characteristic	Description
Overall Dimensions Standard Mainframe  Height Width Depth	17.78 cm (7.00 in.) 27.02 cm (10.64 in.) 37.85 cm (14.90 in.) <b>Notes:</b> 1.80 cm (.71 in.) added to height when feet are installed. When tilted with front feet extended on table top, height is increased approximately 5.29 cm (2.083 in.) in front and 1.48 cm (.583 in.) in rear.
Weight	8.6 kg (19 lb.)
Maximum Module Weight	1.8 kg (4 lb.)
Materials	Sheet Aluminum (5052-H32) and Cold Rolled Steel
Finish  Unpainted Aluminum Cold Rolled Steel Paint	Conductive Clear Iridite Clear Chromate Zinc Plating Polyurethane Enamel

Figure A-1 shows the PXI-1000 dimensions. The holes shown are for the installation of the optional rack-mount kit. You can install this kit on the front or rear of the chassis, depending on which end of the chassis you wish to face toward the front of the instrument cabinet. Note that the front and rear chassis mounting holes (size M4) are symmetrical.

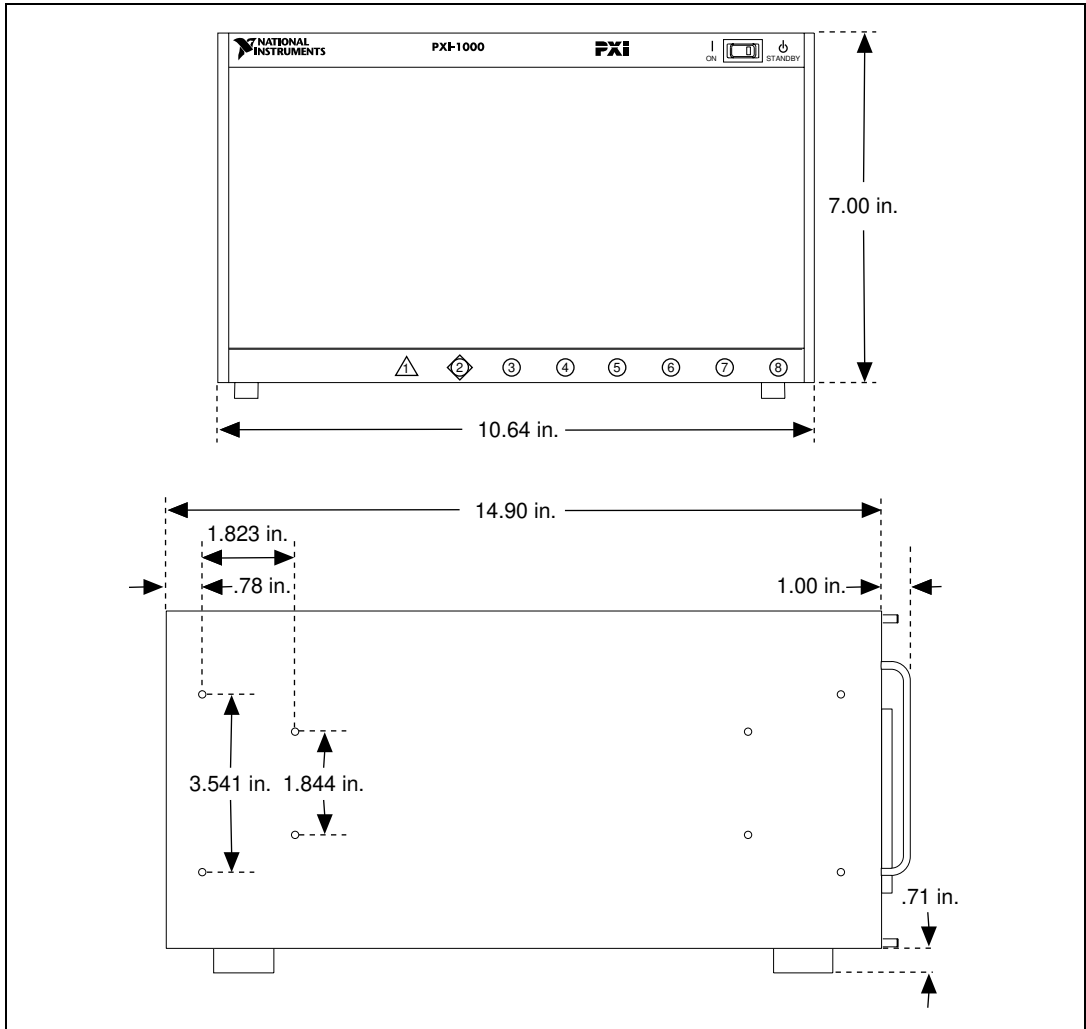

**Figure A-1.** PXI-1000 Dimensions

---

## Pinouts

This appendix describes the P1 and P2 connector pinouts for the PXI-1000 backplane.

Table B-1 shows the P1 (J1) connector pinout for the System Controller slot.

Table B-2 shows the P2 (J2) connector pinout for the System Controller slot.

Table B-3 shows the P1 (J1) connector pinout for the Star Trigger slot.

Table B-4 shows the P2 (J2) connector pinout for the Star Trigger slot.

Table B-5 shows the P1 (J1) connector pinout for the peripheral slots.

Table B-6 shows the P2 (J2) connector pinout for the peripheral slots.



**Note**

*PXI signals are shown in boldface.*

**Table B-1.** P1 (J1) Connector Pinout for the System Controller Slot

Pin	Z	A	B	C	D	E	F
25	GND	5V	REQ64#	ENUM#	3.3V	5V	GND
24	GND	AD[1]	5V	V(I/O)	AD[0]	ACK64#	GND
23	GND	3.3V	AD[4]	AD[3]	5V	AD[2]	GND
22	GND	AD[7]	GND	3.3V	AD[6]	AD[5]	GND
21	GND	3.3V	AD[9]	AD[8]	M66EN	C/BE[0]#	GND
20	GND	AD[12]	GND	V(I/O)	AD[11]	AD[10]	GND
19	GND	3.3V	AD[15]	AD[14]	GND	AD[13]	GND
18	GND	SERR#	GND	3.3V	PAR	C/BE[1]#	GND
17	GND	3.3V	SDONE	SBO#	GND	PERR#	GND
16	GND	DEVSEL#	GND	V(I/O)	STOP#	LOCK#	GND
15	GND	3.3V	FRAME#	IRDY#	GND	TRDY#	GND
12–14	Key Area						
11	GND	AD[18]	AD[17]	AD[16]	GND	C/BE[2]#	GND
10	GND	AD[21]	GND	3.3V	AD[20]	AD[19]	GND
9	GND	C/BE[3]#	IDSEL	AD[23]	GND	AD[22]	GND
8	GND	AD[26]	GND	V(I/O)	AD[25]	AD[24]	GND
7	GND	AD[30]	AD[29]	AD[28]	GND	AD[27]	GND
6	GND	REQ#	GND	3.3V	CLK	AD[31]	GND
5	GND	BRSVP1A5	BRSVP1B5	RST#	GND	GNT#	GND
4	GND	BRSVP1A4	GND	V(I/O)	INTP	INTS	GND
3	GND	INTA#	INTB#	INTC#	5V	INTD#	GND
2	GND	TCK	5V	TMS	TDO	TDI	GND
1	GND	5V	-12V	TRST#	+12V	5V	GND

**Table B-2.** P2 (J2) Connector Pinout for the System Controller Slot

Pin	Z	A	B	C	D	E	F
22	GND	<b>PXI_RSVA22</b>	<b>PXI_RSVB22</b>	<b>PXI_RSVC22</b>	<b>PXI_RSVD22</b>	<b>PXI_RSVE22</b>	GND
21	GND	RSV	GND	RSV	RSV	RSV	GND
20	GND	RSV	RSV	RSV	GND	RSV	GND
19	GND	RSV	GND	RSV	RSV	RSV	GND
18	GND	<b>PXI_TRIG3</b>	<b>PXI_TRIG4</b>	<b>PXI_TRIG5</b>	GND	<b>PXI_TRIG6</b>	GND
17	GND	<b>PXI_TRIG2</b>	GND	PRST#	REQ6#	GNT6#	GND
16	GND	<b>PXI_TRIG1</b>	<b>PXI_TRIG0</b>	DEG#	GND	<b>PXI_TRIG7</b>	GND
15	GND	<b>PXI_BRSVA15</b>	GND	FAL#	REQ5#	GNT5#	GND
14	GND	AD[35]	AD[34]	AD[33]	GND	AD[32]	GND
13	GND	AD[38]	GND	V(I/O)	AD[37]	AD[36]	GND
12	GND	AD[42]	AD[41]	AD[40]	GND	AD[39]	GND
11	GND	AD[45]	GND	V(I/O)	AD[44]	AD[43]	GND
10	GND	AD[49]	AD[48]	AD[47]	GND	AD[46]	GND
9	GND	AD[52]	GND	V(I/O)	AD[51]	AD[50]	GND
8	GND	AD[56]	AD[55]	AD[54]	GND	AD[53]	GND
7	GND	AD[59]	GND	V(I/O)	AD[58]	AD[57]	GND
6	GND	AD[63]	AD[62]	AD[61]	GND	AD[60]	GND
5	GND	C/BE[5]#	GND	V(I/O)	C/BE[4]#	PAR64	GND
4	GND	V(I/O)	<b>PXI_BRSVB4</b>	C/BE[7]#	GND	C/BE[6]#	GND
3	GND	CLK4	GND	GNT3#	REQ4#	GNT4#	GND
2	GND	CLK2	CLK3	SYSEN#	GNT2#	REQ3#	GND
1	GND	CLK1	GND	REQ1#	GNT1#	REQ2#	GND

**Table B-3.** P1 (J1) Connector Pinout for the Star Trigger Slot

Pin	Z	A	B	C	D	E	F
25	GND	5V	REQ64#	ENUM#	3.3V	5V	GND
24	GND	AD[1]	5V	V(I/O)	AD[0]	ACK64#	GND
23	GND	3.3V	AD[4]	AD[3]	5V	AD[2]	GND
22	GND	AD[7]	GND	3.3V	AD[6]	AD[5]	GND
21	GND	3.3V	AD[9]	AD[8]	M66EN	C/BE[0]#	GND
20	GND	AD[12]	GND	V(I/O)	AD[11]	AD[10]	GND
19	GND	3.3V	AD[15]	AD[14]	GND	AD[13]	GND
18	GND	SERR#	GND	3.3V	PAR	C/BE[1]#	GND
17	GND	3.3V	SDONE	SBO#	GND	PERR#	GND
16	GND	DEVSEL#	GND	V(I/O)	STOP#	LOCK#	GND
15	GND	3.3V	FRAME#	IRDY#	GND	TRDY#	GND
12–14	Key Area						
11	GND	AD[18]	AD[17]	AD[16]	GND	C/BE[2]#	GND
10	GND	AD[21]	GND	3.3V	AD[20]	AD[19]	GND
9	GND	C/BE[3]#	IDSEL	AD[23]	GND	AD[22]	GND
8	GND	AD[26]	GND	V(I/O)	AD[25]	AD[24]	GND
7	GND	AD[30]	AD[29]	AD[28]	GND	AD[27]	GND
6	GND	REQ#	GND	3.3V	CLK	AD[31]	GND
5	GND	BRSVP1A5	BRSVP1B5	RST#	GND	GNT#	GND
4	GND	BRSVP1A4	GND	V(I/O)	INTP	INTS	GND
3	GND	INTA#	INTB#	INTC#	5V	INTD#	GND
2	GND	TCK	5V	TMS	TDO	TDI	GND
1	GND	5V	-12V	TRST#	+12V	5V	GND



**Table B-4.** P2 (J2) Connector Pinout for the Star Trigger Slot

Pin	Z	A	B	C	D	E	F
22	GND	PXI_RSVA22	PXI_RSVB22	PXI_RSVC22	PXI_RSVD22	PXI_RSVE22	GND
21	GND	PXI_LBR0	GND	PXI_LBR1	PXI_LBR2	PXI_LBR3	GND
20	GND	PXI_LBR4	PXI_LBR5	PXI_STAR0	GND	PXI_STAR1	GND
19	GND	PXI_STAR2	GND	PXI_STAR3	PXI_STAR4	PXI_STAR5	GND
18	GND	PXI_TRIG3	PXI_TRIG4	PXI_TRIG5	GND	PXI_TRIG6	GND
17	GND	PXI_TRIG2	GND	PRST#	PXI_CLK10_IN	PXI_CLK10	GND
16	GND	PXI_TRIG1	PXI_TRIG0	DEG#	GND	PXI_TRIG7	GND
15	GND	PXI_BRSVA15	GND	FAL#	PXI_STAR6	PXI_LBR6	GND
14	GND	AD[35]	AD[34]	AD[33]	GND	AD[32]	GND
13	GND	AD[38]	GND	V(I/O)	AD[37]	AD[36]	GND
12	GND	AD[42]	AD[41]	AD[40]	GND	AD[39]	GND
11	GND	AD[45]	GND	V(I/O)	AD[44]	AD[43]	GND
10	GND	AD[49]	AD[48]	AD[47]	GND	AD[46]	GND
9	GND	AD[52]	GND	V(I/O)	AD[51]	AD[50]	GND
8	GND	AD[56]	AD[55]	AD[54]	GND	AD[53]	GND
7	GND	AD[59]	GND	V(I/O)	AD[58]	AD[57]	GND
6	GND	AD[63]	AD[62]	AD[61]	GND	AD[60]	GND
5	GND	C/BE[5]#	GND	V(I/O)	C/BE[4]#	PAR64	GND
4	GND	V(I/O)	PXI_BRSVB4	C/BE[7]#	GND	C/BE[6]#	GND
3	GND	PXI_LBR7	GND	PXI_LBR8	PXI_LBR9	PXI_LBR10	GND
2	GND	PXI_LBR11	PXI_LBR12	SYSEN#	PXI_STAR7	PXI_STAR8	GND
1	GND	PXI_STAR9	GND	PXI_STAR10	PXI_STAR11	PXI_STAR12	GND

**Table B-5.** P1 (J1) Connector Pinout for the Peripheral Slot

Pin	Z	A	B	C	D	E	F
25	GND	5V	REQ64#	ENUM#	3.3V	5V	GND
24	GND	AD[1]	5V	V(I/O)	AD[0]	ACK64#	GND
23	GND	3.3V	AD[4]	AD[3]	5V	AD[2]	GND
22	GND	AD[7]	GND	3.3V	AD[6]	AD[5]	GND
21	GND	3.3V	AD[9]	AD[8]	M66EN	C/BE[0]#	GND
20	GND	AD[12]	GND	V(I/O)	AD[11]	AD[10]	GND
19	GND	3.3V	AD[15]	AD[14]	GND	AD[13]	GND
18	GND	SERR#	GND	3.3V	PAR	C/BE[1]#	GND
17	GND	3.3V	SDONE	SBO#	GND	PERR#	GND
16	GND	DEVSEL#	GND	V(I/O)	STOP#	LOCK#	GND
15	GND	3.3V	FRAME#	IRDY#	GND	TRDY#	GND
12–14	Key Area						
11	GND	AD[18]	AD[17]	AD[16]	GND	C/BE[2]#	GND
10	GND	AD[21]	GND	3.3V	AD[20]	AD[19]	GND
9	GND	C/BE[3]#	IDSEL	AD[23]	GND	AD[22]	GND
8	GND	AD[26]	GND	V(I/O)	AD[25]	AD[24]	GND
7	GND	AD[30]	AD[29]	AD[28]	GND	AD[27]	GND
6	GND	REQ#	GND	3.3V	CLK	AD[31]	GND
5	GND	BRSVP1A5	BRSVP1B5	RST#	GND	GNT#	GND
4	GND	BRSVP1A4	GND	V(I/O)	INTP	INTS	GND
3	GND	INTA#	INTB#	INTC#	5V	INTD#	GND
2	GND	TCK	5V	TMS	TDO	TDI	GND
1	GND	5V	-12V	TRST#	+12V	5V	GND

**Table B-6.** P2 (J2) Connector Pinout for the Peripheral Slot

Pin	Z	A	B	C	D	E	F
22	GND	PXI_RSVA22	PXI_RSVB22	PXI_RSVC22	PXI_RSVD22	PXI_RSVE22	GND
21	GND	PXI_LBR0	GND	PXI_LBR1	PXI_LBR2	PXI_LBR3	GND
20	GND	PXI_LBR4	PXI_LBR5	PXI_LBL0	GND	PXI_LBL1	GND
19	GND	PXI_LBL2	GND	PXI_LBL3	PXI_LBL4	PXI_LBL5	GND
18	GND	PXI_TRIG3	PXI_TRIG4	PXI_TRIG5	GND	PXI_TRIG6	GND
17	GND	PXI_TRIG2	GND	PRST#	PXI_STAR	PXI_CLK10	GND
16	GND	PXI_TRIG1	PXI_TRIG0	DEG#	GND	PXI_TRIG7	GND
15	GND	PXI_BRSVA15	GND	FAL#	PXI_LBL6	PXI_LBR6	GND
14	GND	AD[35]	AD[34]	AD[33]	GND	AD[32]	GND
13	GND	AD[38]	GND	V(I/O)	AD[37]	AD[36]	GND
12	GND	AD[42]	AD[41]	AD[40]	GND	AD[39]	GND
11	GND	AD[45]	GND	V(I/O)	AD[44]	AD[43]	GND
10	GND	AD[49]	AD[48]	AD[47]	GND	AD[46]	GND
9	GND	AD[52]	GND	V(I/O)	AD[51]	AD[50]	GND
8	GND	AD[56]	AD[55]	AD[54]	GND	AD[53]	GND
7	GND	AD[59]	GND	V(I/O)	AD[58]	AD[57]	GND
6	GND	AD[63]	AD[62]	AD[61]	GND	AD[60]	GND
5	GND	C/BE[5]#	GND	V(I/O)	C/BE[4]#	PAR64	GND
4	GND	V(I/O)	PXI_BRSVB4	C/BE[7]#	GND	C/BE[6]#	GND
3	GND	PXI_LBR7	GND	PXI_LBR8	PXI_LBR9	PXI_LBR10	GND
2	GND	PXI_LBR11	PXI_LBR12	SYSEN#	PXI_LBL7	PXI_LBL8	GND
1	GND	PXI_LBL9	GND	PXI_LBL10	PXI_LBL11	PXI_LBL12	GND



---

# Customer Communication

For your convenience, this appendix contains forms to help you gather the information necessary to help us solve your technical problems and a form you can use to comment on the product documentation. When you contact us, we need the information on the Technical Support Form and the configuration form, if your manual contains one, about your system configuration to answer your questions as quickly as possible.

National Instruments has technical assistance through electronic, fax, and telephone systems to quickly provide the information you need. Our electronic services include a bulletin board service, an FTP site, a fax-on-demand system, and e-mail support. If you have a hardware or software problem, first try the electronic support systems. If the information available on these systems does not answer your questions, we offer fax and telephone support through our technical support centers, which are staffed by applications engineers.

## Electronic Services

### Bulletin Board Support

National Instruments has BBS and FTP sites dedicated for 24-hour support with a collection of files and documents to answer most common customer questions. From these sites, you can also download the latest instrument drivers, updates, and example programs. For recorded instructions on how to use the bulletin board and FTP services and for BBS automated information, call 512 795 6990. You can access these services at:

United States: 512 794 5422

Up to 14,400 baud, 8 data bits, 1 stop bit, no parity

United Kingdom: 01635 551422

Up to 9,600 baud, 8 data bits, 1 stop bit, no parity

France: 01 48 65 15 59

Up to 9,600 baud, 8 data bits, 1 stop bit, no parity

### FTP Support

To access our FTP site, log on to our Internet host, `ftp.natinst.com`, as anonymous and use your Internet address, such as `joesmith@anywhere.com`, as your password. The support files and documents are located in the `/support` directories.

## Fax-on-Demand Support

Fax-on-Demand is a 24-hour information retrieval system containing a library of documents on a wide range of technical information. You can access Fax-on-Demand from a touch-tone telephone at 512 418 1111.

## E-Mail Support (Currently USA Only)

You can submit technical support questions to the applications engineering team through e-mail at the Internet address listed below. Remember to include your name, address, and phone number so we can contact you with solutions and suggestions.

support@natinst.com

## Telephone and Fax Support

National Instruments has branch offices all over the world. Use the list below to find the technical support number for your country. If there is no National Instruments office in your country, contact the source from which you purchased your software to obtain support.

<b>Country</b>	<b>Telephone</b>	<b>Fax</b>
Australia	03 9879 5166	03 9879 6277
Austria	0662 45 79 90 0	0662 45 79 90 19
Belgium	02 757 00 20	02 757 03 11
Brazil	011 288 3336	011 288 8528
Canada (Ontario)	905 785 0085	905 785 0086
Canada (Québec)	514 694 8521	514 694 4399
Denmark	45 76 26 00	45 76 26 02
Finland	09 725 725 11	09 725 725 55
France	01 48 14 24 24	01 48 14 24 14
Germany	089 741 31 30	089 714 60 35
Hong Kong	2645 3186	2686 8505
Israel	03 6120092	03 6120095
Italy	02 413091	02 41309215
Japan	03 5472 2970	03 5472 2977
Korea	02 596 7456	02 596 7455
Mexico	5 520 2635	5 520 3282
Netherlands	0348 433466	0348 430673
Norway	32 84 84 00	32 84 86 00
Singapore	2265886	2265887
Spain	91 640 0085	91 640 0533
Sweden	08 730 49 70	08 730 43 70
Switzerland	056 200 51 51	056 200 51 55
Taiwan	02 377 1200	02 737 4644
United Kingdom	01635 523545	01635 523154
United States	512 795 8248	512 794 5678

# Technical Support Form

Photocopy this form and update it each time you make changes to your software or hardware, and use the completed copy of this form as a reference for your current configuration. Completing this form accurately before contacting National Instruments for technical support helps our applications engineers answer your questions more efficiently.

If you are using any National Instruments hardware or software products related to this problem, include the configuration forms from their user manuals. Include additional pages if necessary.

Name \_\_\_\_\_

Company \_\_\_\_\_

Address \_\_\_\_\_

\_\_\_\_\_

Fax ( \_\_\_\_ ) \_\_\_\_\_ Phone ( \_\_\_\_ ) \_\_\_\_\_

Computer brand \_\_\_\_\_ Model \_\_\_\_\_ Processor \_\_\_\_\_

Operating system (include version number) \_\_\_\_\_

Clock speed \_\_\_\_\_ MHz RAM \_\_\_\_\_ MB Display adapter \_\_\_\_\_

Mouse \_\_\_\_ yes \_\_\_\_ no Other adapters installed \_\_\_\_\_

Hard disk capacity \_\_\_\_\_ MB Brand \_\_\_\_\_

Instruments used \_\_\_\_\_

\_\_\_\_\_

National Instruments hardware product model \_\_\_\_\_ Revision \_\_\_\_\_

Configuration \_\_\_\_\_

National Instruments software product \_\_\_\_\_ Version \_\_\_\_\_

Configuration \_\_\_\_\_

The problem is: \_\_\_\_\_

\_\_\_\_\_

\_\_\_\_\_

\_\_\_\_\_

\_\_\_\_\_

List any error messages: \_\_\_\_\_

\_\_\_\_\_

\_\_\_\_\_

The following steps reproduce the problem: \_\_\_\_\_

\_\_\_\_\_

\_\_\_\_\_

\_\_\_\_\_

\_\_\_\_\_

# PXI-1000 Hardware Configuration Form

Record the settings and revisions of your hardware and software on the line to the right of each item. Complete a new copy of this form each time you revise your software or hardware configuration, and use this form as a reference for your current configuration. Completing this form accurately before contacting National Instruments for technical support helps our applications engineers answer your questions more efficiently.

## National Instruments Products

Complete Part Number \_\_\_\_\_

Serial Number \_\_\_\_\_

Line Voltage \_\_\_\_\_

Fan Speed \_\_\_\_\_

Safety Ground Connected? \_\_\_\_\_

Rack-Mount or Bench Top Configuration? \_\_\_\_\_

Using Remote Power Monitoring \_\_\_\_\_

Filler Panels Installed in Empty Slots? \_\_\_\_\_

## Other Products

List and describe all devices installed in your mainframe.

Slot	Manufacturer, Description, and Function
1	
2	
3	
4	
5	
6	
7	
8	



# Documentation Comment Form

National Instruments encourages you to comment on the documentation supplied with our products. This information helps us provide quality products to meet your needs.

**Title:** *PXI™-1000 User Manual*

**Edition Date:** January 1998

**Part Number:** 321710B-01

Please comment on the completeness, clarity, and organization of the manual.

---

---

---

---

---

---

---

---

If you find errors in the manual, please record the page numbers and describe the errors.

---

---

---

---

---

---

---

---

Thank you for your help.

Name \_\_\_\_\_

Title \_\_\_\_\_

Company \_\_\_\_\_

Address \_\_\_\_\_

E-Mail Address \_\_\_\_\_

Phone ( \_\_\_ ) \_\_\_\_\_ Fax ( \_\_\_ ) \_\_\_\_\_

**Mail to:** Technical Publications  
National Instruments Corporation  
6504 Bridge Point Parkway  
Austin, Texas 78730-5039

**Fax to:** Technical Publications  
National Instruments Corporation  
512 794 5678

# Glossary

---

Prefix	Meanings	Value
n-	nano-	$10^{-9}$
$\mu$ -	micro-	$10^{-6}$
m-	milli-	$10^{-3}$
c-	centi-	$10^{-2}$
k-	kilo-	$10^3$
M-	mega-	$10^6$

## Symbols

°	Degrees.
$\geq$	Equal or greater than.
$\leq$	Equal or less than.
%	Percent.

## A

A	Amperes.
AC	Alternating current.
ANSI	American National Standards Institute.
AWG	American Wire Gauge.

## B

backplane	An assembly, typically a printed circuit board, with connectors and signal paths that bus the connector pins.
-----------	---

## **C**

C	Celsius.
cfm	Cubic feet per minute.
CFR	Cooperative Fuel Research.
CSA	Canadian Standards Association.

## **D**

daisy-chain	A method of propagating signals along a bus, in which the devices are prioritized on the basis of their position on the bus.
DC	Direct current.

## **E**

ECL	Emitter-coupled logic.
EIA	Electronic Industries Association.
EMC	Electromagnetic Compatibility.

## **F**

FCC	Federal Communications Commission.
-----	------------------------------------

## **G**

g	1) grams 2) A measure of acceleration equal to 9.8 m/s <sup>2</sup> .
GPIB	General Purpose Interface Bus (IEEE 488).
$g_{RMS}$	A measure of random vibration. The root mean square of acceleration levels in a random vibration test profile.

**H**

Hz Hertz; cycles per second.

**I**

IEC International Electrotechnical Commission; an organization that sets international electrical and electronics standards.

IEEE Institute of Electrical and Electronics Engineers.

$I_{MP}$  Mainframe peak current.

in. Inches.

**L**

lb Pounds.

**M**

m Meters.

MTBF Mean time between failure.

MTTR Mean time to repair.

**N**

NEMA National Electrical Manufacturers Association.

**P**

PXI PCI eXtensions for Instrumentation.

**R**

RH Relative humidity.

**RMS** Root mean square. A method used to measure electrical output in volts and watts.

## **S**

**s** Seconds.

**ST** Star Trigger.

**Star Trigger slot** This slot is located at slot 2 and has a dedicated trigger line between each peripheral slot. Use this slot for a module with ST functionality that can provide individual triggers to all other peripherals.

**System controller** A module configured for installation in Slot 0 of a VXIbus mainframe. This device is unique in the VXIbus system in that it performs the VMEbus system controller functions, including clock sourcing and arbitration for data transfers across the backplane. Installing such a device into any other slot can damage the device, the VXIbus backplane, or both.

## **U**

**UL** Underwriter's Laboratories.

## **V**

**V** Volts.

**V<sub>pp</sub>** Peak to peak voltage.

**VAC** Volts alternating current.

## **W**

**W** Watts.

# Index

---

## A

AC input (table), A-1  
AC mains power  
    connecting to, 2-3 to 2-4  
    resetting circuit breaker, 3-3  
air cooling. *See* cooling.

## B

bulletin board support, C-1

## C

cables, power (table), 1-2  
chassis initialization file, 2-7  
circuit breaker, resetting, 3-3  
cleaning  
    exterior cleaning, 3-2  
    fan filters, 3-2  
    interior cleaning, 3-2  
    precautions before cleaning, 3-1  
CompactPCI  
    installing modules (figure), 2-6  
    interoperability with PXI-1000 backplane,  
    1-3  
configuration. *See* installation and configuration.  
connector pinouts. *See* pinouts.  
cooling  
    air cooling of PXI-1000, 2-1 to 2-2  
    air intake (figure), 2-2  
    filler panel installation, 2-7  
    setting fan speed, 2-2  
    specifications (table), A-3  
customer communication, *xii*, C-1 to C-2

## D

DB-9 connector  
    pinout (table), 2-5  
    power supply voltages (table), 2-4  
DC output (table), A-2  
documentation  
    conventions used in manual, *xi*  
    organization of manual, *xi*  
    related documentation, *xii*

## E

electrical specifications, A-1 to A-2  
    AC input (table), A-1  
    DC output (table), A-2  
electronic support services, C-1 to C-2  
e-mail support, C-2  
environmental specifications (table), A-4  
equipment, optional, 1-2

## F

fan  
    cleaning fan filters, 3-2  
    setting speed, 2-2  
    speed selector switch (figure), 1-5  
fax and telephone support, C-2  
Fax-on-Demand support, C-2  
filler panel installation, 2-7  
FTP support, C-1

## G

ground, connecting, 2-3

**I**

- Inhibit signal, turning off power supply outputs, 2-5
- installation and configuration, 2-1 to 2-7
  - chassis initialization file, 2-7
  - connecting safety ground, 2-3
  - connecting to AC mains power, 2-3 to 2-4
  - filler panel installation, 2-7
  - module installation, 2-6 to 2-7
    - CompactPCI or PXI module (figure), 2-6
    - ejector/injector handle position (figure), 2-7
  - rack mounting, 2-2
  - remote power monitoring and inhibit interface, 2-5
  - setting fan speed, 2-2
  - site considerations, 2-1 to 2-2
  - testing power up, 2-3 to 2-4
  - unpacking the PXI-1000, 1-1

**J**

- J1 connector pinouts. *See* P1 (J1) connector pinouts.
- J2 connector pinouts. *See* P2 (J2) connector pinouts.

**L**

- local bus
  - routing (figure), 1-6
  - signals, 1-6

**M**

- maintenance of PXI-1000, 3-1 to 3-4
  - cleaning
    - exterior cleaning, 3-2
    - fan filters, 3-2
    - interior cleaning, 3-2

- precautions before cleaning, 3-1
  - preparation, 3-1
  - resetting AC mains circuit breaker, 3-3
  - service interval, 3-1
  - static discharge damage (caution), 3-1
  - troubleshooting, 3-4
- mechanical specifications, A-6 to A-7

**O**

- optional equipment, 1-2

**P**

- P1 (J1) connector pinouts
  - peripheral slot (table), B-6
  - Star Trigger slot (table), B-4
  - System Controller slot (table), B-2
- P2 (J2) connector pinouts
  - peripheral slot (table), B-7
  - Star Trigger slot (table), B-5
  - System Controller slot (table), B-3
- peripheral slots
  - overview, 1-5
  - P1 (J1) connector pinouts (table), B-6
  - P2 (J2) connector pinouts (table), B-7
- pinouts
  - DB-9 connector (table), 2-5
  - P1 (J1) connector
    - peripheral slot (table), B-6
    - Star Trigger slot (table), B-4
    - System Controller slot (table), B-2
  - P2 (J2) connector
    - peripheral slot (table), B-7
    - Star Trigger slot (table), B-5
    - System Controller slot (table), B-3
- power cables (table), 1-1 to 1-2
- power monitoring connector. *See* DB-9 connector.
- power problems, troubleshooting, 3-4

power supply

- remote power monitoring and inhibit interface, 2-5
- universal, 2-3
- voltages at power monitoring connector (DB-9) (table), 2-4

power up, testing, 2-3 to 2-4

PXI-1000

- cooling air intake (figure), 2-2
- dimensions (figure), A-7
- features, 1-2 to 1-3
- front view (figure), 1-4
- installation (*See* installation and configuration)
- maintenance (*See* maintenance of PXI-1000)
- optional equipment, 1-2
- power cables required (table), 1-1 to 1-2
- rear view (figure), 1-5
- requirements for getting started, 1-1 to 1-2
- specifications (*See* specifications)
- unpacking, 1-1

PXI-1000 backplane, 1-3 to 1-7

- interoperability with CompactPCI, 1-3
- local bus, 1-6
- peripheral slots, 1-5
- specifications (table), A-5
- Star Trigger slot, 1-5
- System Controller slot, 1-5
- system reference clock, 1-7

PXI\_CLK10, 1-7

PXI\_CLK10\_IN pin, 1-7

## R

rack mounting, 2-2

remote power monitoring and inhibit interface, 2-5

## S

safety ground, connecting, 2-3

safety specifications (table), A-3

service interval, 3-1

specifications, A-1 to A-7

- backplane, A-5
- cooling, A-3
- electrical, A-1 to A-2
- environmental, A-4
- mechanical, A-7
- safety, A-3

Star Trigger (ST) slot

- description, 1-5
- P1 (J1) connector pinouts (table), B-4
- P2 (J2) connector pinouts (table), B-5
- triggers for peripheral slots (figure), 1-6

static discharge damage (caution), 3-1

System Controller slot

- description, 1-5
- P1 (J1) connector pinouts (table), B-2
- P2 (J2) connector pinouts (table), B-3

system reference clock, 1-7

## T

technical support, C-1 to C-2

telephone and fax support, C-2

trigger bus, 1-6 to 1-7

troubleshooting the PXI-1000, 3-4

## U

unpacking the PXI-1000, 1-1

## V

voltages at power monitoring connector (DB-9) (table), 2-4