

COMPREHENSIVE SERVICES

We offer competitive repair and calibration services, as well as easily accessible documentation and free downloadable resources.

SELL YOUR SURPLUS

We buy new, used, decommissioned, and surplus parts from every NI series. We work out the best solution to suit your individual needs.

 Sell For Cash  Get Credit  Receive a Trade-In Deal

OBSOLETE NI HARDWARE IN STOCK & READY TO SHIP

We stock **New**, **New Surplus**, **Refurbished**, and **Reconditioned** NI Hardware.



Bridging the gap between the manufacturer and your legacy test system.

 1-800-915-6216

 www.apexwaves.com

 sales@apexwaves.com

All trademarks, brands, and brand names are the property of their respective owners.

Request a Quote

 **CLICK HERE**

PXI-8196

NI 9155

Reconfigurable Embedded Chassis with Integrated MXI-Express (x1)

This document describes the features of the NI 9155 and contains information about mounting and operating the device.

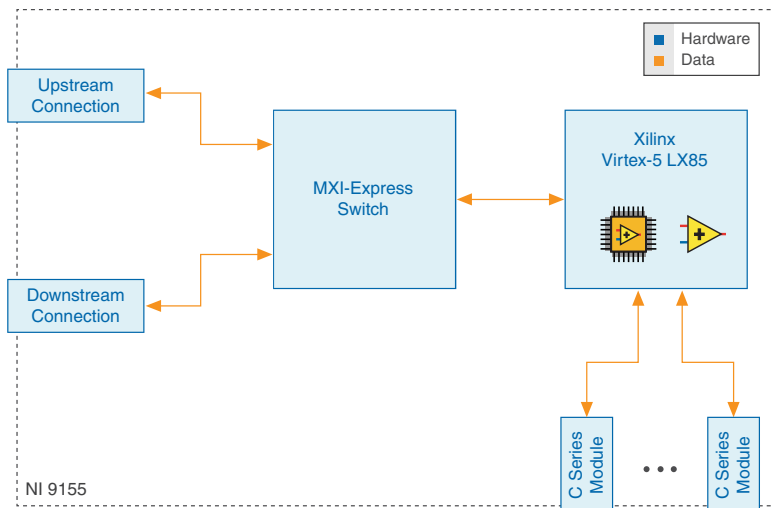

Configuring the NI 9155

You can connect the NI 9155 to a MXI-Express host system and configure the powerup options using a MXI-Express cable.

Connecting One or More NI 9155 Chassis to the MXI-Express Host System or a Target

Complete the following steps to connect one or more NI 9155 chassis to a MXI-Express host system or a target.

1. Make sure the MXI-Express host system is set up and configured as described in the *MXI-Express (x1) Series User Manual*.
2. If the MXI-Express host system is powered up, power it down.
3. If the NI 9155 is powered up, power it down.

4. Use a MXI-Express (x1) cable to connect the MXI-Express host system to the Upstream port of the first NI 9155 in the chain.
5. Use a MXI-Express (x1) cable to connect the Downstream port of the first NI 9155 to the Upstream port of the next NI 9155 in the chain.



Note The maximum number of NI 9155 chassis in a chain depends on the system configuration. For example, a PXI system with an NI PXI-8196 controller can support four chassis per chain. Different types of systems may support more or fewer chassis per chain. For more information about how different system configurations can affect the maximum number of chassis in a chain, go to ni.com/info and enter the Info Code 915xchain.

6. Power up all of the connected NI 9155 chassis.
7. Power up the MXI-Express host system.



Note Refer to the *MXI-Express (x1) Series User Manual* for connectivity options and supported host devices.



Caution All connected NI 9155 chassis must have power connected before the host system is powered up. The BIOS and OS of the host system must detect all bus segments on the chassis side in order to configure the PCI hierarchy. Powering connected chassis up or down while the host system is running can cause system hangs and data corruption.



Caution Do not remove MXI-Express (x1) cables while power is connected. Doing so can cause hangs or application errors. If a cable becomes unplugged, plug it back in and reboot.

Configuring DIP Switches

Figure 1. DIP Switches

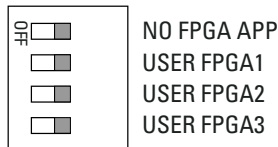

All of the DIP switches are in the OFF position when the chassis is shipped from National Instruments.

NO FPGA APP Switch

Push the NO FPGA APP switch to the ON position to prevent a LabVIEW FPGA application from loading at startup. The NO FPGA APP switch overrides the chassis powerup options described in the section on chassis powerup options. After startup you can download to the FPGA from software regardless of switch position.

USER FPGA Switches

You can define the USER FPGA switches for your application. Use the LabVIEW FPGA Module and NI-RIO software to define the USER FPGA switches to meet the needs of your application. Refer to the *LabVIEW Help* for information about programming these switches.

NI 9155 Features

The NI 9155 provides the following features.

Ports and Connectors

The NI 9155 provides the following ports and connectors.

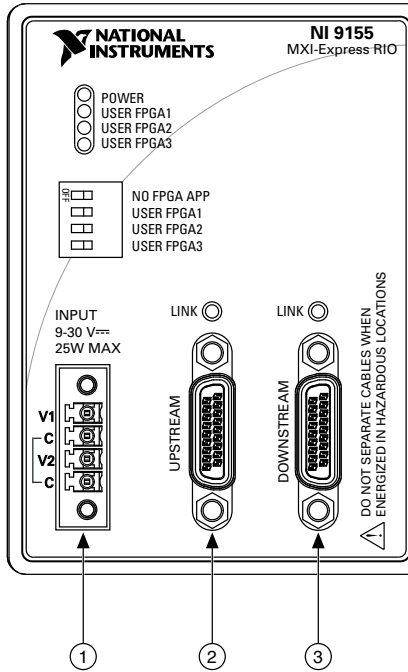

1. Power Connector
2. MXI Express Upstream Port
3. MXI Express Downstream Port

Power Connector

The NI 9155 has a power connector to which you can connect a primary and secondary power supply. The following table shows the pinout for the power connector.

Table 1. Power Connector Pinout

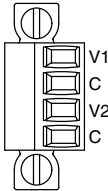
Pinout	Pin	Description
	V1	Primary power input
	C	Common
	V2	Secondary power input
	C	Common



Caution The C terminals are internally connected to each other, but are not connected to chassis ground. This isolation is intended to prevent ground loops and does not meet UL ratings for safety isolation. You can connect the C terminals to chassis ground externally. Refer to the specifications on ni.com/manuals for information about the power supply input range and maximum voltage from terminal to chassis ground.

If you apply power to both the V1 and V2 inputs, the NI 9155 operates from the V1 input. If the input voltage to V1 is insufficient, the NI 9155 operates from the V2 input.

The NI 9155 has reverse-voltage protection.

The following NI power supplies and accessories are available for the NI 9155.

Table 2. Power Accessories

Accessory	Part Number
NI PS-15 Power Supply, 24 VDC, 5 A, 100-120/200-240 VAC Input	781093-01
NI PS-10 Desktop Power Supply, 24 VDC, 5 A, 100-120/200-240 VAC Input	782698-01

MXI Express Port

You can use the MXI Express port on the NI 9155 to connect to a MXI Express chassis. Complete the following steps to connect one or more NI 9155 to a MXI Express device.

1. Make sure the MXI Express device is configured and powered off.
2. Make sure the NI 9155 is powered off.
3. Connect the NI 9155 to the MXI Express device using a x1 cable.
4. Power on the MXI Express device.
5. Power on the NI 9155.

The MXI Express LINK LED on the front panel of the NI 9155 lights green when communication is established. The LINK LED lights yellow when communication is broken or no cable is connected.



Note The NI 9155 may not detect MXI Express devices connected while the NI 9155 is powered on.

The following table shows the MXI Express cables available from NI.

Table 3. NI MXI Express Cables

Length	Part Number
1 m	779500-01
3 m	779500-03
7 m	779500-07

Buttons

The NI 9155 provides the following buttons.

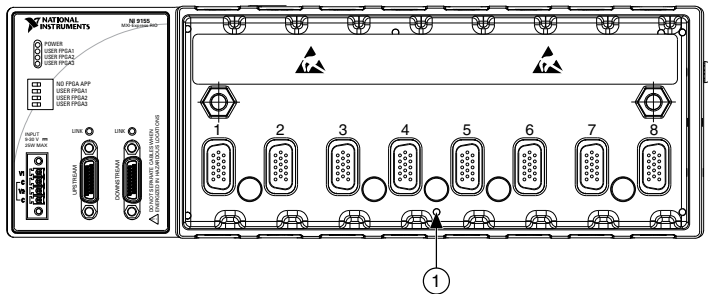

1. CMOS Reset Button

CMOS Reset Button

The NI 9155 has a CMOS reset button that you can use to reset the CMOS and the BIOS.

LEDs

The NI 9155 provides the following LEDs.

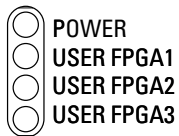

POWER LED

The POWER LED is lit while the NI 9155 is powered on. This LED is a bi-color LED. When the chassis is powered from V1, the POWER LED is lit green. When the chassis is powered from V2, the POWER LED is lit yellow.

USER FPGA LEDs

You can use the bi-color, yellow and green USER FPGA LEDs to help debug your application or easily retrieve application status. Use the LabVIEW FPGA Module and NI-RIO software to define the USER FPGA LEDs to meet the needs of your application. Refer to *LabVIEW Help* for information about programming these LEDs.

Chassis Grounding Screw

The NI 9155 provides a chassis grounding screw.

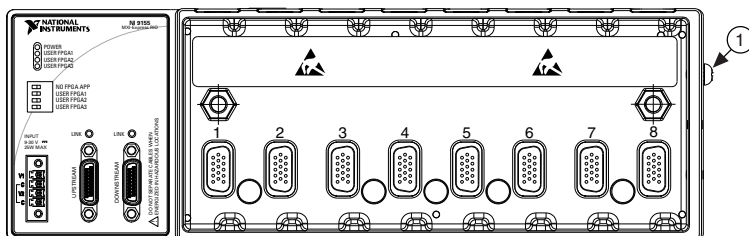

1. Chassis Grounding Screw

For EMC compliance, you must connect the NI 9155 to earth ground through the chassis ground screw. Use wire that is 2.05 mm² (12 AWG) solid copper wire with a maximum length of 1.5 m (5 ft). Attach the wire to the earth ground of the electrode system of the facility.



Caution If you use shielded cabling to connect to a C Series module with a plastic connector, you must attach the cable shield to the chassis grounding terminal using 1.3 mm diameter (16 AWG) or larger wire. Attach a ring lug to the wire and attach the wire to the chassis grounding terminal. Solder the other end of the wire to the cable shield. Use shorter wire for better EMC performance.

For more information about ground connections, visit ni.com/info and enter the Info Code `emcground`.

Mounting the Device

To obtain the maximum allowable ambient temperature of 55 °C, you must mount the NI 9155 horizontally on a 35-mm DIN rail or a flat, metallic, vertical surface such as a panel or wall. You can mount the NI 9155 directly to the surface or use the NI Panel Mounting Kit. The following figure shows the NI 9155 mounted horizontally. Mounting the NI 9155 in other orientations or on a nonmetallic surface can reduce the maximum allowable ambient temperature and can affect the typical accuracy of modules in the NI 9155.

Figure 2. NI 9155 Horizontal Mounting

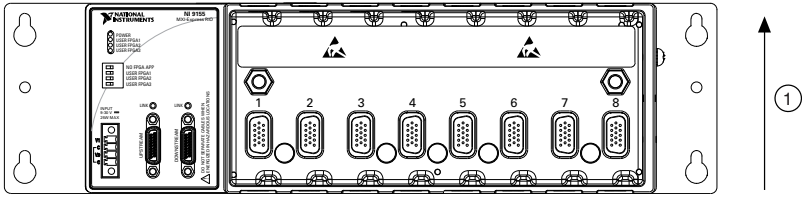

1. Up



Note For more information about how different mounting configurations can cause temperature derating, visit ni.com/info and enter the Info Code *criomounting*.



Note For more information about typical accuracy specifications for C Series modules, visit ni.com/info and enter the Info Code *criotypical*.



Caution Make sure that no C Series modules are in the NI 9155 before mounting it.

Dimensions

The following figures show the front and side dimensions of the NI 9155. For detailed dimensional drawings and 3D models, visit ni.com/dimensions and search for the module number.

Figure 3. NI 9155 Front Dimensions

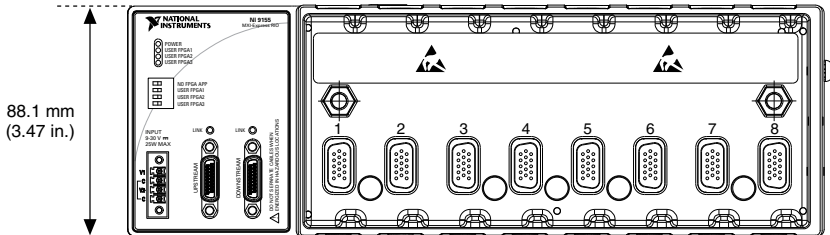
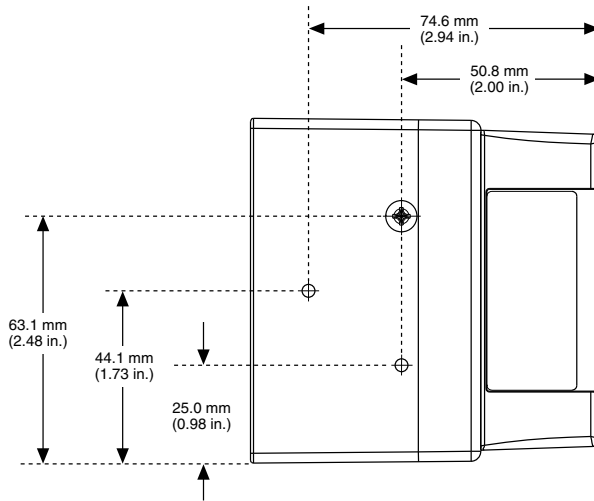

Figure 4. NI 9155 Side Dimensions



Mounting Requirements

Your installation must meet the following requirements for cooling and cabling clearance.

Allow 50.8 mm (2.00 in.) on the top and the bottom of the NI 9155 for air circulation, as shown in the following figure.

Figure 5. NI 9155 Cooling Dimensions

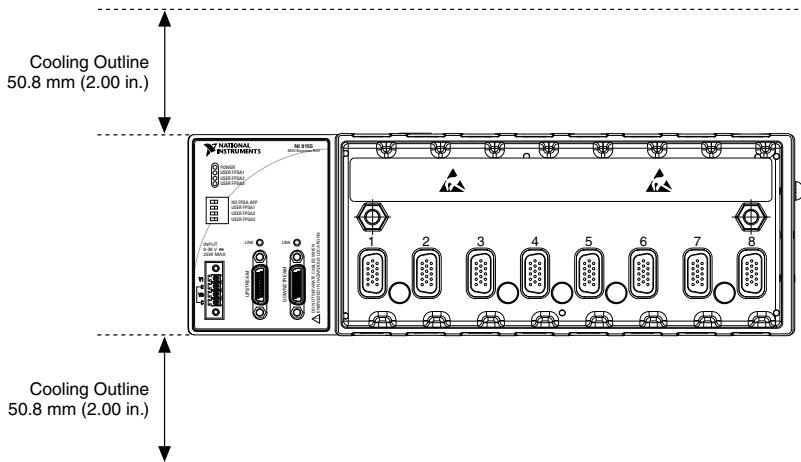

Allow the appropriate space in front of C Series modules for cabling clearance, as shown in the following figure. The different connector types on C Series modules require different

cabling clearances. For a complete list of cabling clearances for C Series modules, visit ni.com/info and enter the Info Code `crioconn`.

Figure 6. NI 9155 Cabling Clearance

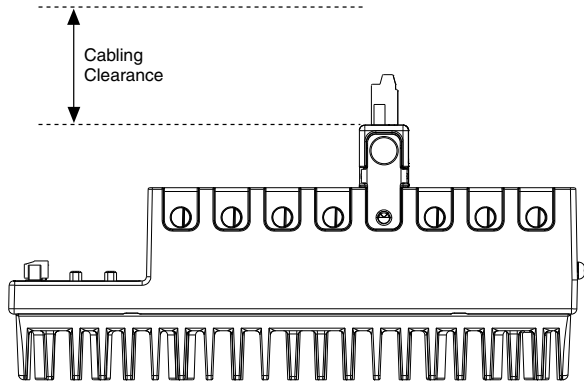

Ambient Temperature

Measure the ambient temperature at each side of the NI 9155, 63.5 mm (2.50 in.) from the side and 50.8 mm (2.00 in.) forward from the rear of the NI 9155, as shown in the following figure.

Figure 7. NI 9155 Ambient Temperature Location

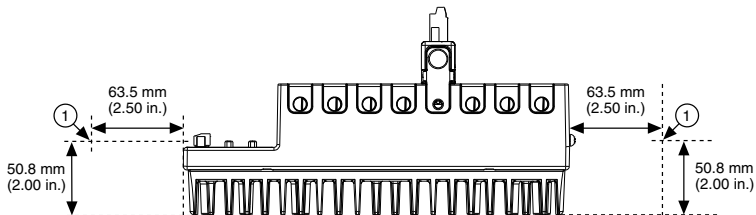

1. Location for measuring the ambient temperature

Mounting the Device on a DIN Rail

You can use the NI DIN rail mounting kit to mount the NI 9155 on a standard 35-mm DIN rail.

What to Use

- NI 9155
- Screwdriver, Phillips #2
- NI DIN rail mounting kit, 779018-01
 - DIN rail clip
 - M4x50 screw (x2)

What to Do

Complete the following steps to mount the NI 9155 on a DIN rail.

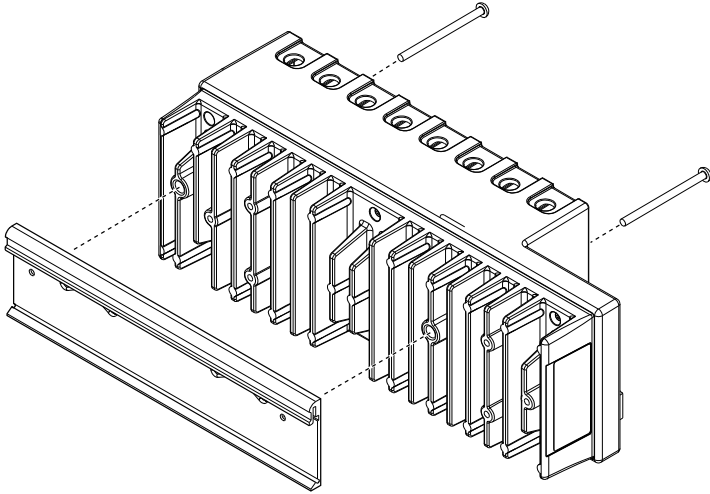

1. Align the NI 9155 and the DIN rail clip.
2. Fasten the DIN rail kit to the NI 9155 using the screwdriver and M4x50 screws. NI provides these screws with the DIN rail mounting kit. Tighten the screws to a maximum torque of $1.3 \text{ N} \cdot \text{m}$ ($11.5 \text{ lb} \cdot \text{in.}$).



Note You must use the screws provided with the NI DIN rail mounting kit because they are the correct depth and thread for the DIN rail clip.

Clipping the Device on a DIN Rail

Complete the following steps to clip the NI 9155 on a DIN rail.

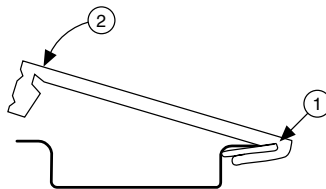

1. Insert one edge of the DIN rail into the deeper opening of the DIN rail clip.
2. Press down firmly to compress the spring until the clip locks in place on the DIN rail.



Caution Ensure that no C Series modules are in the NI 9155 before removing it from the DIN rail.

Mounting the Device on a Panel

You can use the NI panel mounting kit to mount the NI 9155 on a panel.

What to Use

- NI 9155
- Screwdriver, Phillips #2
- NI panel mounting kit, 782818-01
 - Panel mounting plate
 - M4x50 screw (x2)

What to Do

Complete the following steps to mount the NI 9155 on a panel.

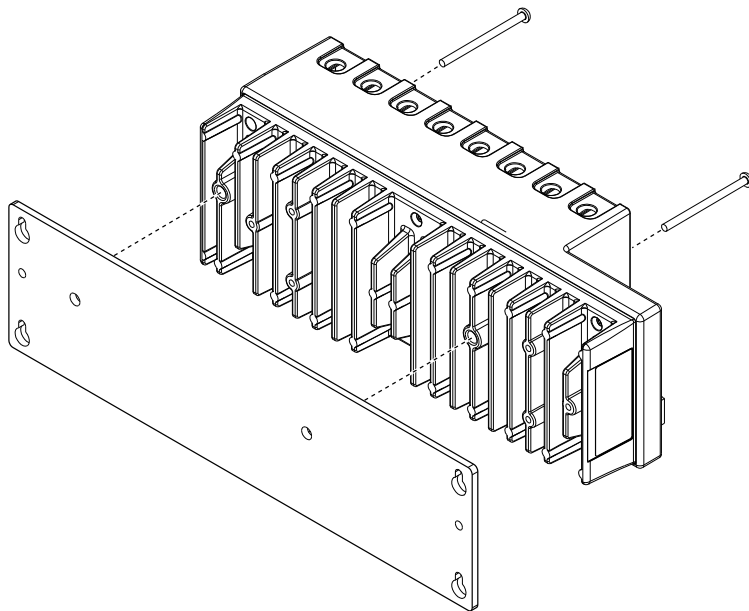

1. Align the NI 9155 and the panel mounting plate.
2. Fasten the panel mounting plate to the NI 9155 using the screwdriver and M4x50 screws. NI provides these screws with the panel mounting kit. Tighten the screws to a maximum torque of $1.3 \text{ N} \cdot \text{m}$ (11.5 lb · in.).



Note You must use the screws provided with the NI panel mounting kit because they are the correct depth and thread for the panel mounting plate.

3. Fasten the panel mounting plate to the surface using the screwdriver and screws that are appropriate for the surface. The maximum screw size is M5 or number 10.

Panel Mounting Dimensions

The following figure shows the panel mounting dimensions for the NI 9155.

Figure 8. NI 9155 Panel Mounting Dimensions

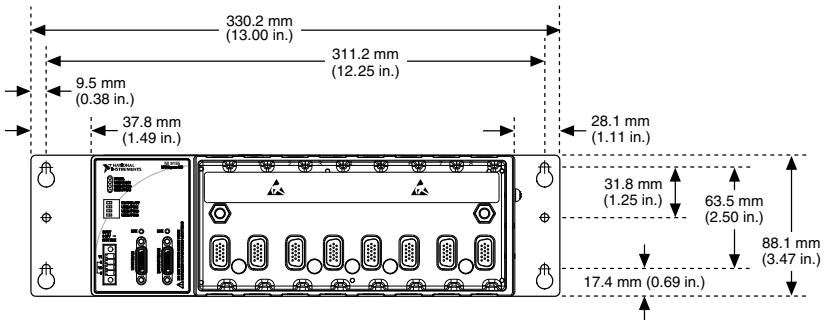

Mounting the Device Directly on a Flat Surface

For environments with high shock and vibration, NI recommends mounting the NI 9155 directly on a flat, rigid surface using the mounting holes in the NI 9155.

What to Use

- NI 9155
- M4 screw (x2), user provided, which must not exceed 8 mm of insertion into the NI 9155

What to Do

Complete the following steps to mount the NI 9155 directly on a flat surface.

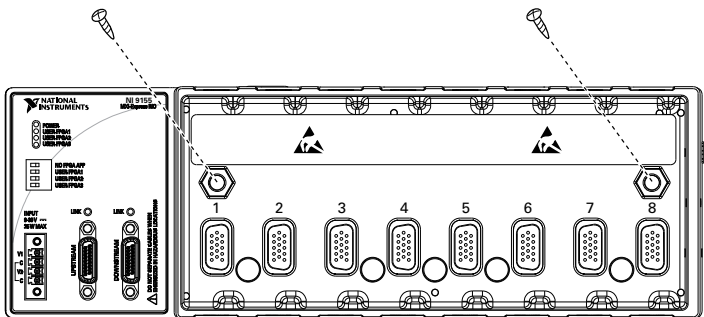

1. Align the NI 9155 on the surface.
2. Fasten the NI 9155 to the surface using the M4 screws appropriate for the surface. Screws must not exceed 8 mm of insertion into the NI 9155. Tighten the screws to a maximum torque of $1.3 \text{ N} \cdot \text{m}$ ($11.5 \text{ lb} \cdot \text{in.}$).

Worldwide Support and Services

The NI website is your complete resource for technical support. At ni.com/support, you have access to everything from troubleshooting and application development self-help resources to email and phone assistance from NI Application Engineers.

Visit ni.com/services for NI Factory Installation Services, repairs, extended warranty, and other services.

Visit ni.com/register to register your NI product. Product registration facilitates technical support and ensures that you receive important information updates from NI.

A Declaration of Conformity (DoC) is our claim of compliance with the Council of the European Communities using the manufacturer's declaration of conformity. This system affords the user protection for electromagnetic compatibility (EMC) and product safety. You can obtain the DoC for your product by visiting ni.com/certification. If your product supports calibration, you can obtain the calibration certificate for your product at ni.com/calibration.

NI corporate headquarters is located at 11500 North Mopac Expressway, Austin, Texas, 78759-3504. NI also has offices located around the world. For telephone support in the United States, create your service request at ni.com/support or dial 1 866 ASK MYNI (275 6964). For telephone support outside the United States, visit the *Worldwide Offices* section of ni.com/niglobal to access the branch office websites, which provide up-to-date contact information, support phone numbers, email addresses, and current events.

Refer to the *NI Trademarks and Logo Guidelines* at ni.com/trademarks for information on NI trademarks. Other product and company names mentioned herein are trademarks or trade names of their respective companies. For patents covering NI products/technology, refer to the appropriate location: **Help»Patents** in your software, the `patents.txt` file on your media, or the *National Instruments Patent Notice* at ni.com/patents. You can find information about end-user license agreements (EULAs) and third-party legal notices in the readme file for your NI product. Refer to the *Export Compliance Information* at ni.com/legal/export-compliance for the NI global trade compliance policy and how to obtain relevant HTS codes, ECCNs, and other import/export data. NI MAKES NO EXPRESS OR IMPLIED WARRANTIES AS TO THE ACCURACY OF THE INFORMATION CONTAINED HEREIN AND SHALL NOT BE LIABLE FOR ANY ERRORS. U.S. Government Customers: The data contained in this manual was developed at private expense and is subject to the applicable limited rights and restricted data rights as set forth in FAR 52.227-14, DFAR 252.227-7014, and DFAR 252.227-7015.

© 2016 National Instruments. All rights reserved.

375994A-03 Apr16