

## COMPREHENSIVE SERVICES

We offer competitive repair and calibration services, as well as easily accessible documentation and free downloadable resources.

## SELL YOUR SURPLUS

We buy new, used, decommissioned, and surplus parts from every NI series. We work out the best solution to suit your individual needs.

 Sell For Cash    Get Credit    Receive a Trade-In Deal

## OBSOLETE NI HARDWARE IN STOCK & READY TO SHIP

We stock **New**, **New Surplus**, **Refurbished**, and **Reconditioned** NI Hardware.



*Bridging the gap between the manufacturer and your legacy test system.*

 1-800-915-6216

 [www.apexwaves.com](http://www.apexwaves.com)

 [sales@apexwaves.com](mailto:sales@apexwaves.com)

*All trademarks, brands, and brand names are the property of their respective owners.*

**Request a Quote**

 **CLICK HERE**

**PXIe-1086**

# PXI Express™

PXIe-1086 User Manual

## Worldwide Technical Support and Product Information

[ni.com](http://ni.com)

## Worldwide Offices

Visit [ni.com/niglobal](http://ni.com/niglobal) to access the branch office websites, which provide up-to-date contact information, support phone numbers, email addresses, and current events.

## National Instruments Corporate Headquarters

11500 North Mopac Expressway Austin, Texas 78759-3504 USA Tel: 512 683 0100

For further support information, refer to the [NI Services](#) appendix. To comment on National Instruments documentation, refer to the National Instruments website at [ni.com/info](http://ni.com/info) and enter the Info Code [feedback](#).

# Legal Information

---

## Limited Warranty

This document is provided 'as is' and is subject to being changed, without notice, in future editions. For the latest version, refer to [ni.com/manuals](http://ni.com/manuals). NI reviews this document carefully for technical accuracy; however, NI MAKES NO EXPRESS OR IMPLIED WARRANTIES AS TO THE ACCURACY OF THE INFORMATION CONTAINED HEREIN AND SHALL NOT BE LIABLE FOR ANY ERRORS.

NI warrants that its hardware products will be free of defects in materials and workmanship that cause the product to fail to substantially conform to the applicable NI published specifications for one (1) year from the date of invoice.

For a period of ninety (90) days from the date of invoice, NI warrants that (i) its software products will perform substantially in accordance with the applicable documentation provided with the software and (ii) the software media will be free from defects in materials and workmanship.

If NI receives notice of a defect or non-conformance during the applicable warranty period, NI will, in its discretion: (i) repair or replace the affected product, or (ii) refund the fees paid for the affected product. Repaired or replaced Hardware will be warranted for the remainder of the original warranty period or ninety (90) days, whichever is longer. If NI elects to repair or replace the product, NI may use new or refurbished parts or products that are equivalent to new in performance and reliability and are at least functionally equivalent to the original part or product.

You must obtain an RMA number from NI before returning any product to NI. NI reserves the right to charge a fee for examining and testing Hardware not covered by the Limited Warranty.

This Limited Warranty does not apply if the defect of the product resulted from improper or inadequate maintenance, installation, repair, or calibration (performed by a party other than NI); unauthorized modification; improper environment; use of an improper hardware or software key; improper use or operation outside of the specification for the product; improper voltages; accident, abuse, or neglect; or a hazard such as lightning, flood, or other act of nature.

THE REMEDIES SET FORTH ABOVE ARE EXCLUSIVE AND THE CUSTOMER'S SOLE REMEDIES, AND SHALL APPLY EVEN IF SUCH REMEDIES FAIL OF THEIR ESSENTIAL PURPOSE.

EXCEPT AS EXPRESSLY SET FORTH HEREIN, PRODUCTS ARE PROVIDED "AS IS" WITHOUT WARRANTY OF ANY KIND AND NI DISCLAIMS ALL WARRANTIES, EXPRESSED OR IMPLIED, WITH RESPECT TO THE PRODUCTS, INCLUDING ANY IMPLIED WARRANTIES OF MERCHANTABILITY, FITNESS FOR A PARTICULAR PURPOSE, TITLE OR NON-INFRINGEMENT, AND ANY WARRANTIES THAT MAY ARISE FROM USAGE OF TRADE OR COURSE OF DEALING. NI DOES NOT WARRANT, GUARANTEE, OR MAKE ANY REPRESENTATIONS REGARDING THE USE OF OR THE RESULTS OF THE USE OF THE PRODUCTS IN TERMS OF CORRECTNESS, ACCURACY, RELIABILITY, OR OTHERWISE. NI DOES NOT WARRANT THAT THE OPERATION OF THE PRODUCTS WILL BE UNINTERRUPTED OR ERROR FREE.

In the event that you and NI have a separate signed written agreement with warranty terms covering the products, then the warranty terms in the separate agreement shall control.

## Copyright

Under the copyright laws, this publication may not be reproduced or transmitted in any form, electronic or mechanical, including photocopying, recording, storing in an information retrieval system, or translating, in whole or in part, without the prior written consent of National Instruments Corporation.

National Instruments respects the intellectual property of others, and we ask our users to do the same. NI software is protected by copyright and other intellectual property laws. Where NI software may be used to reproduce software or other materials belonging to others, you may use NI software only to reproduce materials that you may reproduce in accordance with the terms of any applicable license or other legal restriction.

## End-User License Agreements and Third-Party Legal Notices

You can find end-user license agreements (EULAs) and third-party legal notices in the following locations:

- Notices are located in the <National Instruments>\\_Legal Information and <National Instruments> directories.
- EULAs are located in the <National Instruments>\Shared\MDF\Legal\license directory.
- Review <National Instruments>\\_Legal Information.txt for information on including legal information in installers built with NI products.

## U.S. Government Restricted Rights

If you are an agency, department, or other entity of the United States Government ("Government"), the use, duplication, reproduction, release, modification, disclosure or transfer of the technical data included in this manual is governed by the Restricted Rights provisions under Federal Acquisition Regulation 52.227-14 for civilian agencies and Defense Federal Acquisition Regulation Supplement Section 252.227-7014 and 252.227-7015 for military agencies.

## Trademarks

Refer to the *NI Trademarks and Logo Guidelines* at [ni.com/trademarks](http://ni.com/trademarks) for more information on National Instruments trademarks.

ARM, Keil, and  $\mu$ Vision are trademarks or registered of ARM Ltd or its subsidiaries.

LEGO, the LEGO logo, WEDO, and MINDSTORMS are trademarks of the LEGO Group.

TETRIX by Pitsco is a trademark of Pitsco, Inc.

FIELDBUS FOUNDATION™ and FOUNDATION™ are trademarks of the Fieldbus Foundation.



EtherCAT® is a registered trademark of and licensed by Beckhoff Automation GmbH.

CANopen® is a registered Community Trademark of CAN in Automation e.V.

DeviceNet™ and EtherNet/IP™ are trademarks of ODVA.

Go!, SensorDAQ, and Vernier are registered trademarks of Vernier Software & Technology. Vernier Software & Technology and [vernier.com](http://vernier.com) are trademarks or trade dress.

Xilinx is the registered trademark of Xilinx, Inc.

Taprite and Trilobular are registered trademarks of Research Engineering & Manufacturing Inc.

FireWire® is the registered trademark of Apple Inc.

Linux® is the registered trademark of Linus Torvalds in the U.S. and other countries.

Handle Graphics®, MATLAB®, Real-Time Workshop®, Simulink®, Stateflow®, and xPC TargetBox® are registered trademarks, and TargetBox™ and Target Language Compiler™ are trademarks of The MathWorks, Inc.

Tektronix®, Tek, and Tektronix, Enabling Technology are registered trademarks of Tektronix, Inc.

The Bluetooth® word mark is a registered trademark owned by the Bluetooth SIG, Inc.

The ExpressCard™ word mark and logos are owned by PCMCIA and any use of such marks by National Instruments is under license.

The mark LabWindows is used under a license from Microsoft Corporation. Windows is a registered trademark of Microsoft Corporation in the United States and other countries.

Other product and company names mentioned herein are trademarks or trade names of their respective companies.

Members of the National Instruments Alliance Partner Program are business entities independent from National Instruments and have no agency, partnership, or joint-venture relationship with National Instruments.

## Patents

For patents covering National Instruments products/technology, refer to the appropriate location: **Help»Patents** in your software, the `patents.txt` file on your media, or the *National Instruments Patent Notice* at [ni.com/patents](http://ni.com/patents).

## Export Compliance Information

Refer to the *Export Compliance Information* at [ni.com/legal/export-compliance](http://ni.com/legal/export-compliance) for the National Instruments global trade compliance policy and how to obtain relevant HTS codes, ECCNs, and other import/export data.

## WARNING REGARDING USE OF NATIONAL INSTRUMENTS PRODUCTS

YOU ARE ULTIMATELY RESPONSIBLE FOR VERIFYING AND VALIDATING THE SUITABILITY AND RELIABILITY OF THE PRODUCTS WHENEVER THE PRODUCTS ARE INCORPORATED IN YOUR SYSTEM OR APPLICATION, INCLUDING THE APPROPRIATE DESIGN, PROCESS, AND SAFETY LEVEL OF SUCH SYSTEM OR APPLICATION.

PRODUCTS ARE NOT DESIGNED, MANUFACTURED, OR TESTED FOR USE IN LIFE OR SAFETY CRITICAL SYSTEMS, HAZARDOUS ENVIRONMENTS OR ANY OTHER ENVIRONMENTS REQUIRING FAIL-SAFE PERFORMANCE, INCLUDING IN THE OPERATION OF NUCLEAR FACILITIES; AIRCRAFT NAVIGATION; AIR TRAFFIC CONTROL SYSTEMS; LIFE SAVING OR LIFE SUSTAINING SYSTEMS OR SUCH OTHER MEDICAL DEVICES; OR ANY OTHER APPLICATION IN WHICH THE FAILURE OF THE PRODUCT OR SERVICE COULD LEAD TO DEATH, PERSONAL INJURY, SEVERE PROPERTY DAMAGE OR ENVIRONMENTAL HARM (COLLECTIVELY, "HIGH-RISK USES"). FURTHER, PRUDENT STEPS MUST BE TAKEN TO PROTECT AGAINST FAILURES, INCLUDING PROVIDING BACK-UP AND SHUT-DOWN MECHANISMS. NI EXPRESSLY DISCLAIMS ANY EXPRESS OR IMPLIED WARRANTY OF FITNESS OF THE PRODUCTS OR SERVICES FOR HIGH-RISK USES.

# Compliance

---

## Electromagnetic Compatibility Information

This hardware has been tested and found to comply with the applicable regulatory requirements and limits for electromagnetic compatibility (EMC) as indicated in the hardware's Declaration of Conformity (DoC)<sup>1</sup>. These requirements and limits are designed to provide reasonable protection against harmful interference when the hardware is operated in the intended electromagnetic environment. In special cases, for example when either highly sensitive or noisy hardware is being used in close proximity, additional mitigation measures may have to be employed to minimize the potential for electromagnetic interference.

While this hardware is compliant with the applicable regulatory EMC requirements, there is no guarantee that interference will not occur in a particular installation. To minimize the potential for the hardware to cause interference to radio and television reception or to experience unacceptable performance degradation, install and use this hardware in strict accordance with the instructions in the hardware documentation and the DoC<sup>1</sup>.

If this hardware does cause interference with licensed radio communications services or other nearby electronics, which can be determined by turning the hardware off and on, you are encouraged to try to correct the interference by one or more of the following measures:

- Reorient the antenna of the receiver (the device suffering interference).
- Relocate the transmitter (the device generating interference) with respect to the receiver.
- Plug the transmitter into a different outlet so that the transmitter and the receiver are on different branch circuits.

Some hardware may require the use of a metal, shielded enclosure (windowless version) to meet the EMC requirements for special EMC environments such as, for marine use or in heavy industrial areas. Refer to the hardware's user documentation and the DoC<sup>1</sup> for product installation requirements.

When the hardware is connected to a test object or to test leads, the system may become more sensitive to disturbances or may cause interference in the local electromagnetic environment.

Operation of this hardware in a residential area is likely to cause harmful interference. Users are required to correct the interference at their own expense or cease operation of the hardware.

Changes or modifications not expressly approved by National Instruments could void the user's right to operate the hardware under the local regulatory rules.

---

<sup>1</sup> The Declaration of Conformity (DoC) contains important EMC compliance information and instructions for the user or installer. To obtain the DoC for this product, visit [ni.com/certification](http://ni.com/certification), search by model number or product line, and click the appropriate link in the Certification column.

# Contents

---

## About This Manual

Related Documentation .....	xi
-----------------------------	----

## Chapter 1

### Getting Started

Unpacking.....	1-1
What You Need to Get Started .....	1-1
Key Features .....	1-2
High Performance for Instrumentation Requirements.....	1-2
High Reliability .....	1-3
High Availability .....	1-3
Multi-Chassis Support .....	1-3
Optional Features.....	1-3
Chassis Description .....	1-4
Optional Equipment.....	1-5
EMC Filler Panels .....	1-5
Power Supply Filler Panels.....	1-5
Rack Mount Kit .....	1-5
Slot Blockers.....	1-5
Replacement Power Supply.....	1-6
Replacement Fan Modules .....	1-6
PXIe-1086 Chassis Backplane Overview .....	1-6
Interoperability with CompactPCI.....	1-6
System Controller Slot.....	1-6
Hybrid Peripheral Slots .....	1-7
System Timing Slot .....	1-8
PXI Local Bus .....	1-9
PXI Trigger Bus.....	1-9
System Reference Clock.....	1-10
PXIe_SYNC_CTRL .....	1-11

## Chapter 2

### Installation and Configuration

Safety Information .....	2-1
Chassis Cooling Considerations .....	2-2
Providing Adequate Clearance .....	2-2
Chassis Ambient Temperature Definition .....	2-4
Setting Fan Speed .....	2-5
Installing Filler Panels .....	2-5
Installing Slot Blockers .....	2-5
Fan Access Door Clearance.....	2-5
Rack Mounting .....	2-6

Contents

Connecting Safety Ground.....2-6  
Connecting to Power Source.....2-6  
Installing a PXI Express System Controller .....2-7  
Installing Peripheral Modules .....2-8  
Remote System Monitoring .....2-10  
    Default Configuration Settings .....2-11  
Chassis LED Indicators .....2-11  
Remote Inhibit and Fault Monitoring .....2-13  
Inhibit Mode Switch .....2-14  
PXI\_CLK10 Connectors .....2-14  
PXI Express System Configuration with MAX.....2-14  
    PXI-1 System Configuration .....2-15  
    Trigger Configuration in MAX.....2-16  
    PXI Trigger Bus Routing .....2-16  
Using System Configuration and Initialization Files.....2-17

**Chapter 3  
Maintenance**

Service Interval .....3-1  
Preparation .....3-1  
Cleaning .....3-1  
    Interior Cleaning .....3-1  
    Exterior Cleaning .....3-2  
Replacing a Modular Power Supply .....3-2  
    Removal .....3-2  
    Installation .....3-5  
Replacing a Modular Fan Assembly.....3-6  
    Removal .....3-6  
    Installation .....3-8

**Appendix A  
Specifications**

**Appendix B  
Pinouts**

**Appendix C  
TI StellarisWare Clickwrap Software License Agreement (SLA)**

**Appendix D  
NI Services**

Glossary

Index

# About This Manual

---

The *NI PXIe-1086 User Manual* describes the features of the NI PXIe-1086 chassis and contains information about configuring the chassis, installing the modules, and operating the chassis.

## Related Documentation

---

The following documents contain information that you might find helpful as you read this manual:

- IEEE 1101.1-1991, *IEEE Standard for Mechanical Core Specifications for Microcomputers Using IEC 603-2 Connectors*
- IEEE 1101.10, *IEEE Standard for Additional Mechanical Specifications for Microcomputers Using IEEE 1101.1 Equipment Practice*
- *PICMG EXP.0 R1.0 CompactPCI Express Specification*, PCI Industrial Computers Manufacturers Group
- *PCI Express Base Specification*, Revision 1.1, PCI Special Interest Group
- *PXI-5 PXI Express Hardware Specification*, Revision 2.0, PXI Systems Alliance

---

# Getting Started

This chapter describes the key features of the PXIe-1086 chassis and lists the kit contents and optional equipment you can order from National Instruments.

## Unpacking

---

Carefully inspect the shipping container and the chassis for damage. Check for visible damage to the metal work. Check to make sure all handles, hardware, and switches are undamaged. Inspect the inner chassis for any possible damage, debris, or detached components. If damage appears to have been caused during shipment, file a claim with the carrier. Retain the packing material for possible inspection and/or reshipment.

## What You Need to Get Started

---

The PXIe-1086 chassis kit contains the following items:

- PXIe-1086 chassis
- Filler panels
- PXIe-1086 Getting Started Guide*
- Software media with *PXI Platform Services 14.0* or later
- Read Me First: Safety and Electromagnetic Compatibility*
- Chassis number labels
- Inhibit fault cable connector



**Note** An AC power cable is also required, but not included in the PXIe-1086 chassis kit. Refer to Table 1-1 for more information about AC power cables.

**Table 1-1. AC Power Cables**

Power Cable	Reference Standards
Standard 120 V (USA)	ANSI C73.11/NEMA 5-15-P/IEC83
Switzerland 220 V	SEV
Australia 240 V	AS C112
Universal Euro 230 V	CEE (7), II, IV, VII IEC83
United Kingdom 230 V	BS 1363/IEC83

If you are missing any of the items listed in Table 1-1, or if you have the incorrect AC power cable, contact National Instruments.

## Key Features

The PXIe-1086 chassis combines a high-performance 18-slot PXI Express backplane with a high-output power supply and a structural design that has been optimized for maximum usability in a wide range of applications. The chassis' modular design ensures a high level of maintainability, resulting in a very low mean time to repair (MTTR). The chassis also features redundant power supplies and fans designed to maximize system availability. The PXIe-1086 chassis fully complies with the *PXI-5 PXI Express Hardware Specification*, offering advanced timing and synchronization features.

The key features of the PXIe-1086 chassis include the following:

## High Performance for Instrumentation Requirements

- Up to 4 GB/s (single direction) per PXI Express slot dedicated bandwidth (Gen-2 x8 PCI Express)
- 38.25 W per slot cooling meets increased PXI Express cooling requirements
- Low-jitter internal 10 MHz reference clock for PXI slots with  $\pm 25$  ppm stability
- Low-jitter internal 100 MHz reference clock for PXI Express slots with  $\pm 25$  ppm stability
- Variable speed fan controller optimizes cooling and acoustic emissions
- Remote power-inhibit control
- Complies with PXI and CompactPCI Specifications



## High Reliability

- 0 to 50 °C operating temperature range
- Power supply, temperature, and fan monitoring
- Ethernet interface for remote monitoring

## High Availability

- Dual redundant, hot-swappable power supplies
- Redundant, hot-swappable chassis fans

## Multi-Chassis Support

- PXI Express System Timing Slot for tight synchronization across chassis
- Front CLK10 I/O connectors
- Switchless CLK10 routing

## Optional Features

- Front and rear rack-mount kits
- Replacement power supply
- EMC filler panels
- Slot blockers for improved cooling performance
- Factory installation services
- Replacement fan modules

# Chassis Description

Figures 1-1 and 1-2 show the key features of the PXIe-1086 chassis front and back panels. Figure 1-1 shows the front view of the PXIe-1086. Figure 1-2 shows the rear view of the PXIe-1086.

**Figure 1-1. Front View of the PXIe-1086 Chassis (with Optional Filler Panels)**

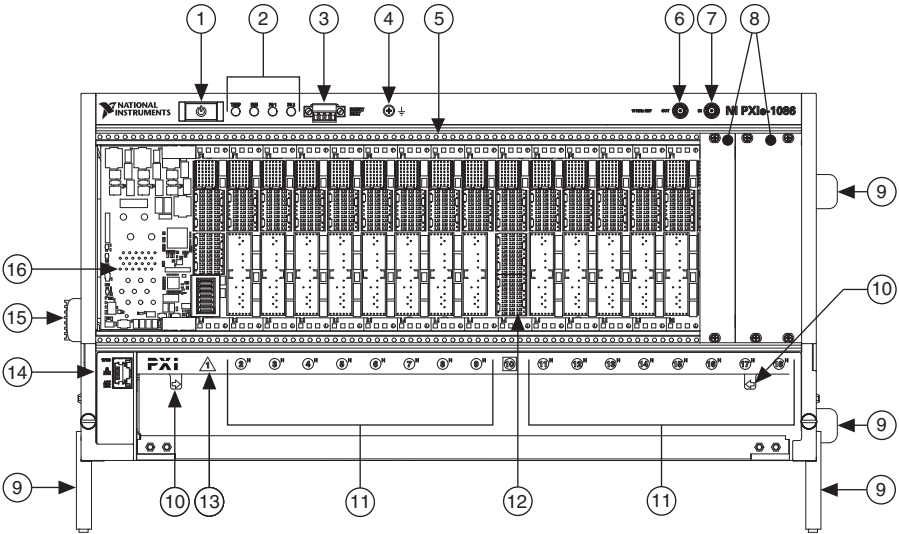

- |                                |  |
|--------------------------------|--|
| 1 Power Inhibit Switch         | 9 Removable Feet                             |
| 2 Status LEDs                  | 10 Fan Door Latch                            |
| 3 Inhibit/Fault Connector      | 11 PXI Express Hybrid Peripheral Slots (16x) |
| 4 Ground Terminal              | 12 PXI Express System Timing Slot            |
| 5 Backplane Connectors         | 13 PXI Express System Controller Slot        |
| 6 Clk10 Output                 | 14 Ethernet Port                             |
| 7 Clk10 Input                  | 15 Chassis Carry Handle                      |
| 8 PXI Filler Panels (Optional) | 16 System Controller Expansion Slots         |

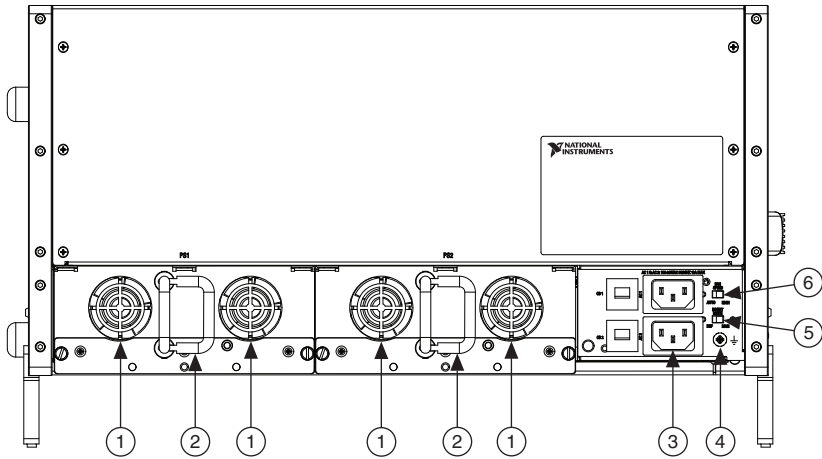
**Figure 1-2. Rear View of the PXIe-1086 Chassis**

- |   |                          |   |                                    |   |                              |
|---|--------------------------|---|------------------------------------|---|------------------------------|
| 1 | Power Supply Cooling Fan | 3 | Chassis Power Connectors           | 5 | Inhibit Mode Selector Switch |
| 2 | Power Supply Handle      | 4 | Protective Conductor Terminal (PE) | 6 | Fan Speed Selector Switch    |

## Optional Equipment

Contact National Instruments to order the following options for the PXIe-1086 chassis.

### EMC Filler Panels

Optional EMC filler panel kits are available from National Instruments.

### Power Supply Filler Panels

Optional power supply filler panels are available from National Instruments. Use a power supply filler panel if you operate the PXIe-1086 chassis with a single power supply.

### Rack Mount Kit

There are two optional kits for mounting the PXIe-1086 chassis into a rack. The first option is a pair of mounting brackets for use on the front of the chassis. The second option is a rear rack mount kit. The rear rack mount kit differs from the front kit to allow for easier installation into the rack. For more information, refer to Figure A-3, *NI Chassis Rack Mount Kit Components*.

### Slot Blockers

Optional Slot Blocker kits are available from National Instruments. Slot Blockers improve cooling in a chassis by re-routing airflow from empty slots to slots containing PXI modules.

## Replacement Power Supply

Replacement power supply kits are available from National Instruments.

## Replacement Fan Modules

Replacement fan modules are available from National Instruments.

## PXle-1086 Chassis Backplane Overview

---

This section provides an overview of the backplane features for the PXle-1086 chassis.

### Interoperability with CompactPCI

The design of the PXle-1086 provides you the flexibility to use the following devices in a single PXI Express chassis:

- PXI Express compatible products
- CompactPCI Express compatible 2-Link system controller products
- CompactPCI Express compatible Type-2 peripheral products
- PXI peripheral products modified to fit in a hybrid slot
- Standard CompactPCI peripheral products modified to fit in a hybrid slot

### System Controller Slot

The system controller slot is Slot 1 of the chassis and is a 2-Link configuration system slot as defined by the CompactPCI Express and PXI Express specifications. It has three expansion slots for system controller modules that are wider than one slot. These slots allow the system controller to expand to the left to prevent it from using peripheral slots.

The backplane connects the system slot to two PCI Express switches using a Gen-2 x8 and a Gen-2 x16 PCI Express link. These switches distribute PCI Express connections to the peripheral slots and to two PCI Express-to-PCI bridges to provide PCI buses to the hybrid peripheral slots. Refer to Figure 1-3.

System slot link 1 is a Gen-2 x8 PCI Express link to PCI Express switch 1, providing a nominal bandwidth of 4 GB/s (single direction) between the system controller and PCI Express switch 1. PXI Express peripheral slots 2-10 are connected to PCI Express switch 1 with Gen-2 x8 PCI Express links and are downstream of system slot link 1. PCI Express-to-PCI bridge 1 is connected to PCI Express switch 1 and provides a 32-bit, 33 MHz PCI bus for hybrid peripheral slots 2-9. PCI Express switch 1 also is connected to PCI Express switch 2 with a Gen-2 x8 PCI Express link for advanced backplane configurations.

System slot link 2 is a Gen-2 x16 PCI Express link to PCI Express switch 2, providing a nominal bandwidth of 8 GB/s (single direction) between the system controller slot and PCI Express switch 2. PXI Express peripheral slots 11-18 are connected to PCI Express switch 2 with Gen-2 x8 PCI Express links and are downstream of system slot link 2. PCI Express-to-PCI bridge 2 is connected to PCI Express switch 2 and provides a 32-bit, 33 MHz PCI bus for hybrid peripheral slots 11-18. PCI Express switch 2 also is connected to PCI Express switch 1 with a Gen-2 x8 PCI Express link for advanced backplane configurations.

The system controller slot also has connectivity to some PXI features such as: PXI\_CLK10, PXI Star, PXI Trigger Bus and PXI Local Bus 6.

By default, the system controller will control the power supply with the PS\_ON# signals. A logic low on this line will turn the power supply on.



**Note** The Inhibit Mode switch on the rear of the chassis must be in the **Default** position for the system controller to have control of the power supply. Refer to the [Inhibit Mode Switch](#) section of Chapter 2, *Installation and Configuration*, for details about the Inhibit Mode switch.

## Hybrid Peripheral Slots

The chassis provides 16 hybrid peripheral slots as defined by the *PXI-5 PXI Express Hardware Specification*: slots 2 to 9 and slots 11 to 18. A hybrid peripheral slot can accept the following peripheral modules:

- A PXI Express peripheral with x8, x4, or x1 PCI Express link through a switch to the system slot. Each PXI Express peripheral slot can link up to a Gen-2 x8 PCI Express, providing a maximum nominal single-direction bandwidth of 4 GB/s.
- A CompactPCI Express Type-2 Peripheral with x8, x4, or x1 PCI Express link through a switch to the system slot.
- A hybrid-compatible PXI Peripheral module that has been modified by replacing the J2 connector with an XJ4 connector installed in the upper eight rows of J2. Refer to the *PXI Express Specification* for details. The PXI Peripheral communicates through the backplane's 32-bit PCI bus.
- A CompactPCI 32-bit peripheral on the backplane's 32-bit PCI bus.

The hybrid peripheral slots provide full PXI Express functionality and 32-bit PXI functionality except for PXI Local Bus. The hybrid peripheral slot only connects to PXI Local Bus 6 left and right.

**Figure 1-3. PXIe-1086 PCI Express Backplane Diagram**

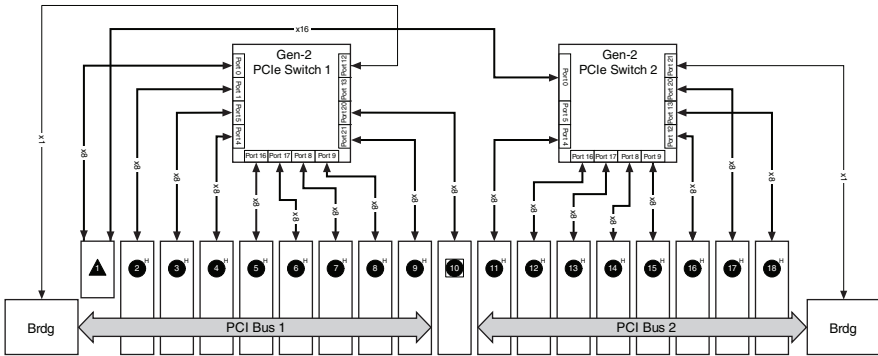

## System Timing Slot

The System Timing Slot is slot 10. The system timing slot will accept the following peripheral modules:

- A PXI Express System Timing Module with x8, x4, or x1 PCI Express link to the system slot through a PCI Express switch. Each PXI Express peripheral slot can link up to a Gen-2 x8 PCI Express, providing a maximum nominal single-direction bandwidth of 4 GB/s.
- A PXI Express Peripheral with x8, x4, or x1 PCI Express link to the system slot through a PCI Express switch.
- A CompactPCI Express Type-2 Peripheral with x8, x4, or x1 PCI Express link to the system slot through a PCI Express switch.

The system timing slot has 3 dedicated differential pairs (PXIe\_DSTAR) connected from the TP1 and TP2 connectors to the XP3 connector for each PXI Express hybrid peripheral slot, as well as routed back to the XP3 connector of the system timing slot as shown in Figure 1-4. The PXIe\_DSTAR pairs can be used for high-speed triggering, synchronization and clocking. Refer to the *PXI Express Specification* for details.

The system timing slot also has a single-ended (PXI Star) trigger connected to every slot. Refer to Figure 1-4 for details.

The system timing slot has a pin (PXI\_CLK10\_IN) through which a system timing module may source a 10 MHz clock to which the backplane will phase-lock. Refer to the *System Reference Clock* section for details.

The system timing slot has a pin (PXIe\_SYNC\_CTRL) through which a system timing module can control the PXIe\_SYNC100 timing. Refer to the *PXI Express Specification* and the *PXIe\_SYNC\_CTRL* section of this chapter for details.

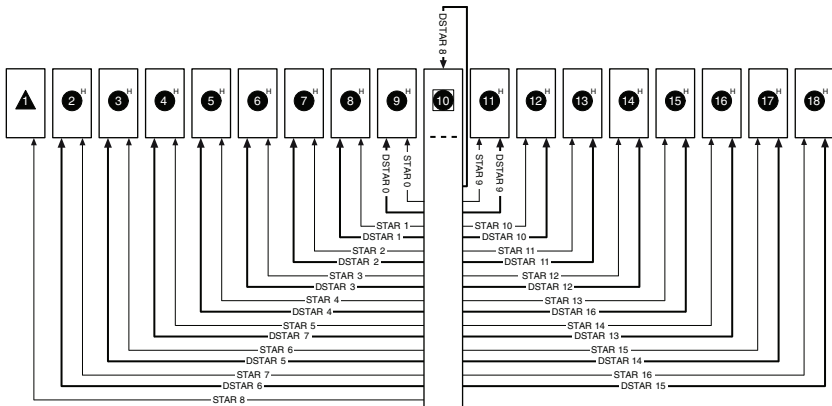
**Figure 1-4. PXI Express Star Connectivity Diagram**

## PXI Local Bus

The PXI backplane local bus is a daisy-chained bus that connects each peripheral slot with adjacent peripheral slots to the left and right, as shown in Figure 1-5.

The backplane routes PXI Local Bus 6 between all slots. The left local bus 6 from slot 1 is not routed anywhere and the right local bus signals from slot 18 are not routed anywhere.

Local bus signals may range from high-speed TTL signals to analog signals as high as 42 V.

Initialization software uses the configuration information specific to each adjacent peripheral module to evaluate local bus compatibility.

## PXI Trigger Bus

All slots on the same PXI bus segment share eight PXI trigger lines. You can use these trigger lines in a variety of ways. For example, you can use triggers to synchronize the operation of several different PXI peripheral modules. In other applications, one module located in the system timing slot can control carefully timed sequences of operations performed on other modules in the system. Modules can pass triggers to one another, allowing precisely timed responses to asynchronous external events the system is monitoring or controlling.

The PXI trigger lines from adjacent PXI trigger bus segments can be routed in either direction across the PXI trigger bridges through buffers. This allows you to send trigger signals to, and receive trigger signals from, every slot in the chassis. Static trigger routing (user-specified line and directional assignments) can be configured through Measurement & Automation Explorer (MAX). Dynamic routing of triggers (automatic line assignments) is supported through certain National Instruments drivers like NI-DAQmx.



**Note** Although any trigger line may be routed in either direction, it cannot be routed in more than one direction at a time.

**Figure 1-5. PXI Trigger Bus Connectivity Diagram**

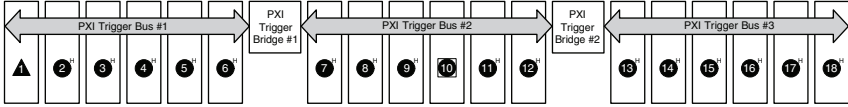

## System Reference Clock

The PXIe-1086 chassis supplies PXI\_CLK10, PXIe\_CLK100, and PXIe\_SYNC100 independently driven to each peripheral slot.

An independent buffer (having a source impedance matched to the backplane and a skew of less than 1 ns between slots) drives PXI\_CLK10 to each slot. You can use this common reference clock signal to synchronize multiple modules in a measurement or control system.

An independent buffer drives PXIe\_CLK100 to each peripheral slot. These clocks are matched in skew to less than 100 ps. The differential pair must be terminated on the peripheral with LVPECL termination for the buffer to drive PXIe\_CLK100 so that when there is no peripheral or a peripheral that does not connect to PXIe\_CLK100, there is no clock being driven on the pair to that slot.

An independent buffer drives PXIe\_SYNC100 to each peripheral slot. The differential pair must be terminated on the peripheral with LVPECL termination for the buffer to drive PXIe\_SYNC100 so that when there is no peripheral or a peripheral that does not connect to PXIe\_SYNC100, there is no SYNC100 signal being driven on the pair to that slot.

PXI\_CLK10, PXIe\_CLK100 and PXIe\_SYNC100 have the default timing relationship described in Figure 1-6.

**Figure 1-6. System Reference Clock Default Behavior**

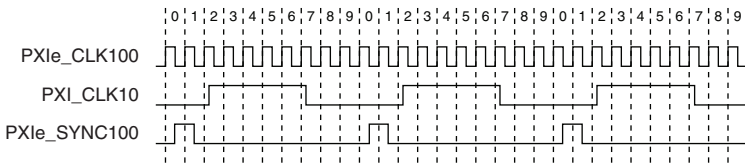

To synchronize the system to an external clock, you can drive PXI\_CLK10 from an external source through the PXI\_CLK10\_IN pin on the System Timing Slot. Refer to Table B-8, *XP4 Connector Pinout for the System Timing Slot*, for the pinout. When a 10MHz clock is detected on this pin, the backplane automatically phase-locks the PXI\_CLK10, PXIe\_CLK100, and PXIe\_SYNC100 signals to this external clock and distributes these signals to the slots. Refer to Appendix A, *Specifications*, for the specification information for an external clock provided on the PXI\_CLK10\_IN pin of the system timing slot.



You also can drive a 10 MHz clock on the 10 MHz REF IN connector on the front panel of the chassis. When a 10 MHz clock is detected on this connector, the backplane automatically phase-locks the PXI\_CLK10, PXIe\_CLK100, and PXIe\_SYNC100 signals to this external clock and distributes these signals to the slots. Refer to Appendix A, *Specifications*, for the specification information for an external clock provided on the 10 MHz REF IN connector on the front panel of the chassis.

If the 10 MHz clock is present on both the PXI\_CLK10\_IN pin of the System Timing Slot and the 10 MHz REF IN connector on the front of the chassis, the signal on the System Timing Slot is selected. Refer to Table 1-2 which explains how the 10 MHz clocks are selected by the backplane.

**Table 1-2.** Backplane External Clock Input Truth Table

<b>System Timing Slot PXI_CLK10_IN</b>	<b>Front Chassis Panel 10 MHz REF IN</b>	<b>Backplane PXI_CLK10, PXIe_CLK100 and PXIe_SYNC100</b>
No clock present	No clock present	Backplane generates its own clocks
No clock present	10 MHz clock present	PXI_CLK10, PXIe_CLK100 and PXIe_SYNC100 all phase-locked to Front Chassis Panel—10 MHz REF IN
10 MHz clock present	No clock present	PXI_CLK10, PXIe_CLK100 and PXIe_SYNC100 all phase-locked to System Timing Slot—PXI_CLK10_IN
10 MHz clock present	10 MHz clock present	PXI_CLK10, PXIe_CLK100 and PXIe_SYNC100 all phase-locked to System Timing Slot—PXI_CLK10_IN

A copy of the backplane's PXI\_CLK10 is exported to the 10 MHz REF OUT connector on the front panel of the chassis. This clock is driven by an independent buffer. Refer to Appendix A, *Specifications*, for the specification information for the 10 MHz REF OUT signal on the front panel of the chassis.

## PXIe\_SYNC\_CTRL

PXIe\_SYNC100 is by default a 10 ns pulse synchronous to PXI\_CLK10. The frequency of PXIe\_SYNC100 is  $10/n$  MHz, where  $n$  is a positive integer. The default for  $n$  is 1, giving PXIe\_SYNC100 a 100 ns period. However, the backplane allows  $n$  to be programmed to other integers. For instance, setting  $n = 3$  gives a PXIe\_SYNC100 with a 300 ns period while still maintaining its phase relationship to PXI\_CLK10. The value for  $n$  may be set to any positive integer from 1 to 255.

The system timing slot has a control pin for PXIe\_SYNC100 called PXIe\_SYNC\_CTRL for use when  $n > 1$ . Refer to Table B-7, *XP3 Connector Pinout for the System Timing Slot*, for system timing slot pinout. Refer to Appendix A, *Specifications*, for the PXIe\_SYNC\_CTRL input specifications.

By default, a high-level detected by the backplane on the PXIe\_SYNC\_CTRL pin causes a synchronous restart for the PXIe\_SYNC100 signal. On the next PXI\_CLK10 edge the PXIe\_SYNC100 signal will restart. This will allow several chassis to have their PXIe\_SYNC100 in phase with each other. Refer to Figure 1-7 for timing details with this method.

**Figure 1-7.** PXIe\_SYNC100 at 3.33 MHz Using PXIe\_SYNC\_CTRL as Restart

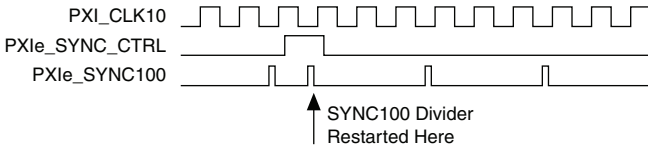

---

# Installation and Configuration

This chapter describes how to prepare and operate the PXIe-1086 chassis.

Before connecting the chassis to a power source, read this chapter and the *Read Me First: Safety and Electromagnetic Compatibility* document included with your kit.

---

## Safety Information

---



**Caution** Before undertaking any troubleshooting, maintenance, or exploratory procedure, carefully read the following caution notices. Protection equipment may be impaired if equipment is not used in the manner specified.

This equipment contains voltage hazardous to human life and safety, and is capable of inflicting personal injury.

- **Chassis Grounding**—The chassis requires a connection from the premise wire safety ground to the protective conductor terminal on the rear of the chassis. The earth safety ground must be connected during use of this equipment to minimize shock hazards. Refer to the [Connecting Safety Ground](#) and [Connecting to Power Source](#) sections for instructions on connecting safety ground.
- **Live Circuits**—Operating personnel and service personnel *must* not remove protective covers when operating or servicing the chassis. Adjustments and service to internal components must be undertaken by qualified service technicians. During service of this product, the mains connector to the premise wiring must be disconnected. Dangerous voltages may be present under certain conditions; use extreme caution.
- **Explosive Atmosphere**—Do *not* operate the chassis in conditions where flammable gases are present. Under such conditions, this equipment is unsafe and may ignite the gases or gas fumes.
- **Part Replacement**—Only service this equipment with parts that are exact replacements, both electrically and mechanically. Contact National Instruments for replacement part information. Installation of parts with those that are not direct replacements may cause harm to personnel operating the chassis. Furthermore, damage or fire may occur if replacement parts are unsuitable.
- **Modification**—Do *not* modify any part of the chassis from its original condition. Unsuitable modifications may result in safety hazards.
- **Location**—The chassis is for use in stationary (non-moveable), restricted access locations such as a desk or bench, or for installation in a rack only. Installation and maintenance are to be performed by skilled/trained service persons.

# Chassis Cooling Considerations

---

The PXIe-1086 chassis is designed to operate on a bench or in an instrument rack. The chassis must be oriented horizontally with the primary exhaust vent at top. Vertical orientation with the chassis handle up is not a supported configuration. Regardless of the configuration, you must provide the cooling clearances as outlined in the following sections.

## Providing Adequate Clearance

The primary cooling exhaust vent for the PXIe-1086 is on the top of the chassis. The primary intake vent is on the bottom of the chassis. The secondary intake vents are located along on the rear of the chassis. Adequate clearance between the chassis and surrounding equipment or blockages must be maintained to ensure proper cooling of the chassis power supply as well as the modules plugged into the chassis. These clearances are outlined in Figure 2-1. The vent locations for the PXIe-1086 chassis are shown in Figure 2-2. Failure to provide these clearances may result in thermal-related failures in the chassis or modules.

**Figure 2-1. PXIe-1086 Cooling Clearances**

Dimensions are in inches (millimeters)

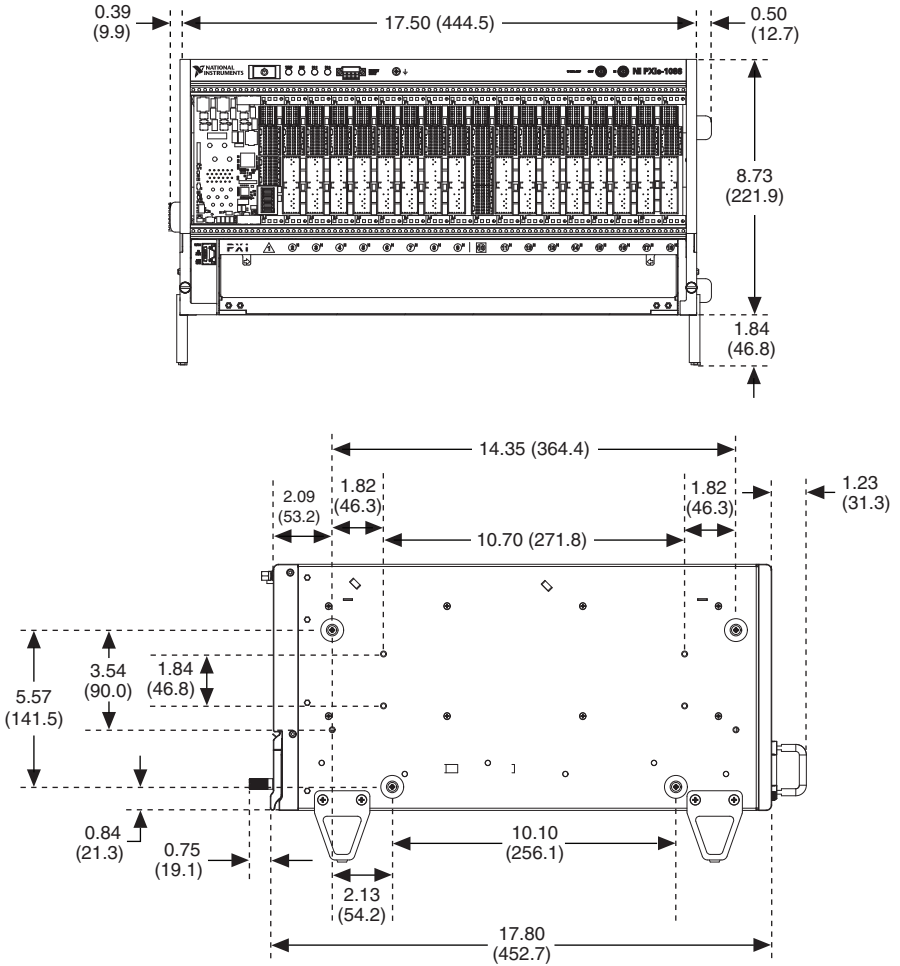

**Figure 2-2. PXIe-1086 Vents**

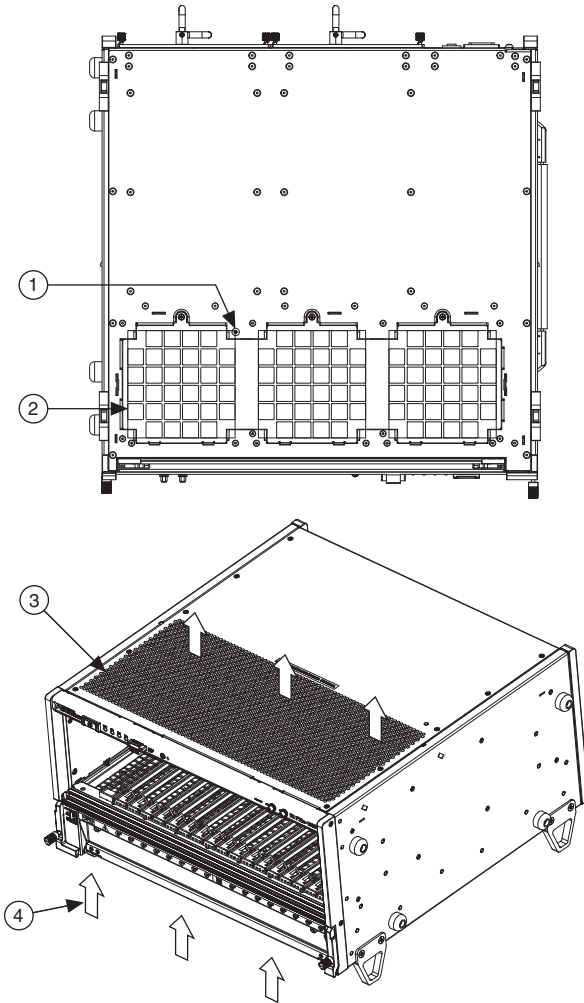

- 1 Ambient Temperature Sensor
- 2 Primary Air Intake Vents

- 3 Air Exhaust Vent
- 4 Airflow

## Chassis Ambient Temperature Definition

The chassis fan control system uses the intake air temperature as the input for controlling fan speeds when in Auto Fan Speed mode. Because of this, the chassis ambient temperature is defined as the temperature of the air just outside of the fan intake vents on the bottom of the chassis. Note that this temperature may be higher than ambient room temperature depending on the surrounding equipment and/or blockages present. It is the user’s responsibility to ensure

that this ambient temperature does not exceed the rated ambient temperature as stated in Appendix A, *Specifications*. If the temperature exceeds the stated spec, the front-panel temperature LED blinks red, as discussed in the *Chassis LED Indicators* section of this chapter.

## Setting Fan Speed

The fan-speed selector switch is on the rear panel of the PXIe-1086 chassis. Refer to Figure 1-2, *Rear View of the PXIe-1086 Chassis*, to locate the fan-speed selector switch. Select **High** for maximum cooling performance or **Auto** for improved acoustic performance. When set to **Auto**, the fan speed is determined by the chassis intake air temperature.

## Installing Filler Panels

To maintain proper module cooling performance, install filler panels (provided with the chassis) in unused or empty slots. Secure with the captive mounting screws provided.

## Installing Slot Blockers

The cooling performance of the chassis can be improved by installing optional Slot Blockers. Refer to [ni.com](http://ni.com) for more details.

## Fan Access Door Clearance

When installing the PXIe-1086 chassis, you also must provide the proper clearance for the fan access door to open fully, as shown in Figure 2-3.

**Figure 2-3.** Fan Access Door Clearance

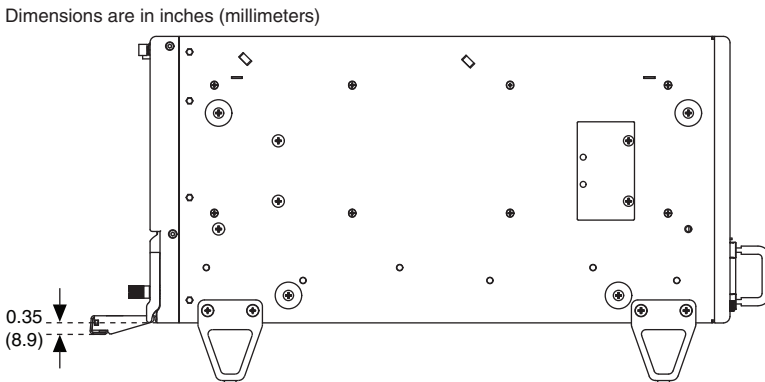

## Rack Mounting

---

Rack mount applications require the optional rack mount kits available from National Instruments. Refer to the instructions supplied with the rack mount kits to install your PXIe-1086 chassis in an instrument rack. Refer to Figure A-3, *NI Chassis Rack Mount Kit Components*.



**Note** You may want to remove the feet and handle from the PXIe-1086 chassis when rack mounting. To do so, remove the screws holding the feet and handle in place.

## Connecting Safety Ground

---



**Caution** The PXIe-1086 chassis are designed with three-position NEMA 5-15 style plugs for the U.S. that connect the ground line to the chassis ground. To minimize shock hazard, make sure the electrical power outlet you use to power the chassis has an appropriate earth safety ground.

Additionally, you must connect the premise safety ground to the chassis grounding screw located on the rear panel. Refer to Figure 1-2, *Rear View of the PXIe-1086 Chassis*, to locate the protective conductor terminal. To connect the safety ground, complete the following steps:

1. Connect a 16 AWG (1.3 mm) wire to the protective conductor terminal using a grounding lug. The wire must have green insulation with a yellow stripe or must be noninsulated (bare). The lug must be sized for the M4 x 6 screw.
2. Attach the opposite end of the wire to permanent earth ground using toothed washers or a toothed lug.

## Connecting to Power Source

---



**Cautions** Do *not* install modules prior to performing the following power-on test.

To completely remove power, you *must* disconnect the AC power cable(s).

Attach input power through the rear AC inlets using the appropriate AC power cable supplied. Refer to Figure 1-2, *Rear View of the PXIe-1086 Chassis*, to locate the AC inlets.

The Inhibit Mode switch allows you to power on the chassis or place it in standby mode. Set the Inhibit Mode switch on the back of the chassis to the **Manual** position. Observe that all fans become operational and all front panel LEDs are a steady green. Switching the Inhibit Mode switch to the **Default** position allows the system controller to control the power supply.



# Installing a PXI Express System Controller

This section contains general installation instructions for installing a PXI Express system controller in a PXIe-1086 chassis. Refer to your PXI Express system controller user manual for specific instructions and warnings. To install a system controller, complete the following steps:

1. Ensure that the chassis is properly grounded to protect it from electrical damage while you install the system controller.
2. Install the system controller into the system controller slot (slot 1, indicated by the red card guides) by first placing the system controller PCB into the front of the card guides (top and bottom). Slide the system controller to the rear of the chassis, making sure that the injector/ejector handle is pushed down as shown in Figure 2-4.

**Figure 2-4.** Installing a PXI Express System Controller

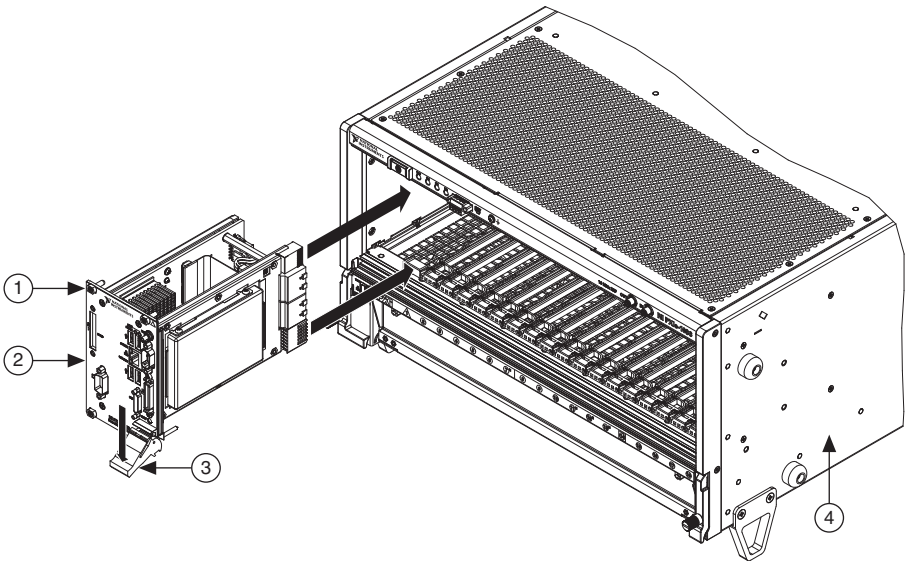

- |  |                           |
|--|---------------------------|
| 1 System Controller Front Panel Mounting Screws (4x) | 3 Injector/Ejector Handle |
| 2 NI PXI Express System Controller                   | 4 PXIe-1086 Chassis       |

3. When you begin to feel resistance, pull up on the injector/ejector handle to seat the system controller fully into the chassis frame. Secure the system controller front panel to the chassis using the system controller front-panel mounting screws.
4. Connect the keyboard, mouse, and monitor to the appropriate connectors. Connect devices to ports as required by your system configuration.
5. Power on the chassis. Verify that the system controller boots. If the system controller does not boot, refer to your system controller user manual.

Figure 2-5 shows a PXI Express system controller installed in the system controller slot of a PXIe-1086 chassis. You can place CompactPCI, CompactPCI Express, PXI, or PXI Express modules in other slots depending on the slot type.

**Figure 2-5.** NI PXI Express System Controller Installed in an PXIe-1086 Chassis

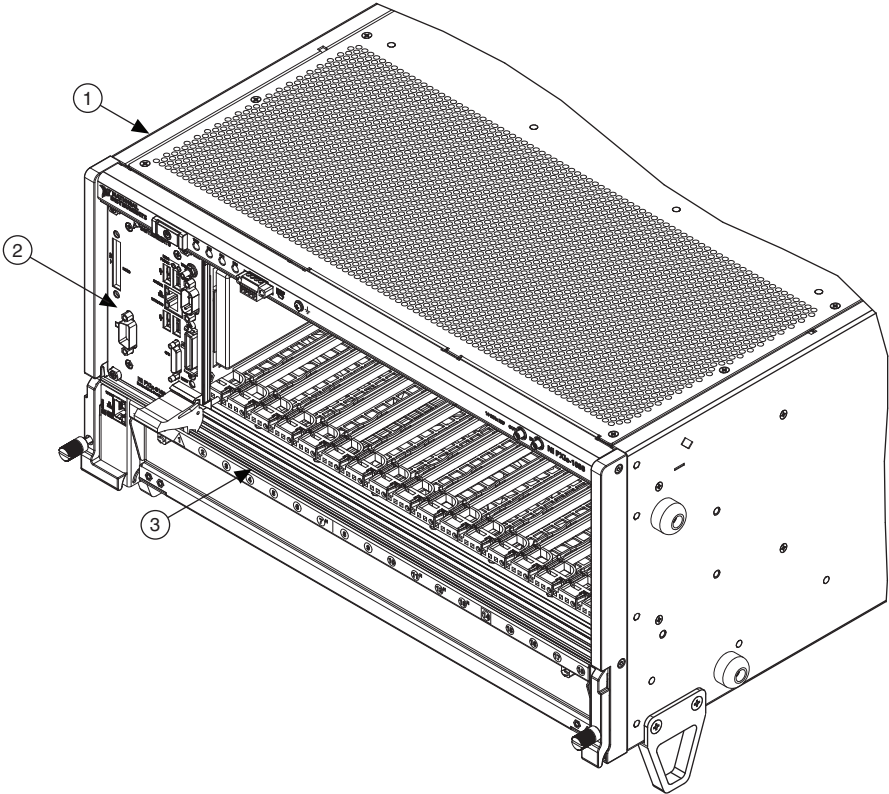

- 
- |                     |                                    |                         |
|---------------------|------------------------------------|-------------------------|
| 1 PXIe-1086 Chassis | 2 NI PXI Express System Controller | 3 Injector/Ejector Rail |
|---------------------|------------------------------------|-------------------------|
- 

## Installing Peripheral Modules

---



**Caution** The PXIe-1086 chassis has been designed to accept a variety of peripheral module types in different slots. To prevent damage to the chassis, ensure that the peripheral module is being installed into a slot designed to accept it. Refer to Chapter 1, *Getting Started*, for a description of the various slot types.

This section contains general installation instructions for installing a peripheral module in a PXIe-1086 chassis. Refer to your peripheral module user manual for specific instructions and warnings. To install a module, complete the following steps:

1. Ensure that the chassis is properly grounded to protect it from electrical damage while you install the module.
2. Ensure that the chassis is powered off.
3. Install a module into a chassis slot by first placing the module card PCB into the front of the card guides (top and bottom), as shown in Figure 2-6. Slide the module to the rear of the chassis, making sure that the injector/ejector handle is pushed down as shown in Figure 2-6.
4. When you begin to feel resistance, push up on the injector/ejector handle to fully seat the module into the chassis frame. Secure the module front panel to the chassis using the module front-panel mounting screws.

**Figure 2-6.** Installing PXI, PXI Express, or CompactPCI Peripheral Modules

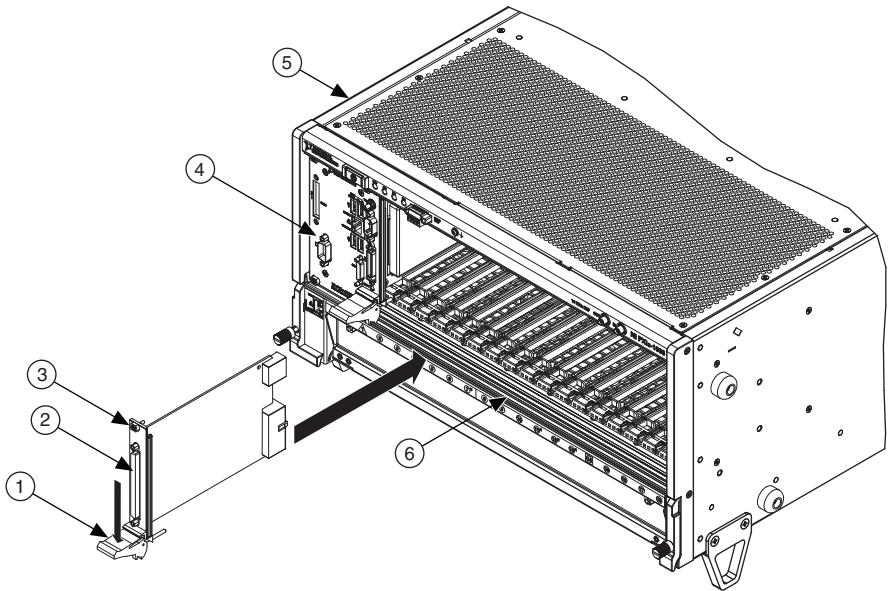

- |   |  |   |                               |
|---|--|---|-------------------------------|
| 1 | Injector/Ejector Handle                            | 4 | PXI Express System Controller |
| 2 | PXI Peripheral Module                              | 5 | PXIe-1086 Chassis             |
| 3 | Peripheral Module Front Panel Mounting Screws (2x) | 6 | Injector/Ejector Rail         |

# Remote System Monitoring

The PXIe-1086 chassis provides an Ethernet port on the front panel of the chassis. You can use this Ethernet port to monitor the chassis operating parameters remotely over a network. Refer to Figure 1-1, *Front View of the PXIe-1086 Chassis (with Optional Filler Panels)*, to locate the Ethernet connector.

The Ethernet port on the chassis supports communication speeds of 10 Mbps and 100 Mbps. Contact your network administrator to determine whether your network supports DHCP. If your network uses DHCP, the network configuration is performed automatically.

To use the remote monitoring interface, connect one end of an Ethernet cable to your PXIe-1086 chassis. Connect the other end of the cable to your Ethernet network.



**Note** The Ethernet controller can perform automatic crossover, thus eliminating the need for crossover cables.

Through the remote monitoring Ethernet interface of the chassis, you can access a web page with information about the current chassis operating parameters. You can access this page in most browsers. Enter the IP address or hostname currently assigned to the chassis into the browser's address bar. Figure 2-7 shows an example of the web page.

**Figure 2-7.** Chassis Configuration Web Page



The Ethernet connector has two LEDs that indicate the current status of the Ethernet link. Table 2-1 describes the behavior of these LEDs.

**Table 2-1. Ethernet LED Behavior**

LED	State	Description
ACT/Link	Off	Link is not established.
	Steady green	Link is established.
	Blinking green	Chassis is communicating with another device on the network.
10/100	Off	10 Mbps data rate is selected.
	Steady green	100 Mbps data rate is selected

## Default Configuration Settings

The chassis ships from the factory with the following default configuration settings:

- DHCP with Auto IP fallback
- Default hostname as printed on the product label

## Chassis LED Indicators

The PXIe-1086 chassis has four main LEDs on the front panel next to the Power Inhibit switch. Refer to Figure 1-1, *Front View of the PXIe-1086 Chassis (with Optional Filler Panels)*, to locate these LEDs.

You can use the four main LEDs to determine the chassis operating status quickly. Table 2-2 describes the behavior of these LEDs.

**Table 2-2. Main Chassis LED Behavior**

LED	State	Description
Temperature Status	Off	Chassis is powered off.
	Steady green	Air intake temperature is within chassis operating range.
	Blinking red	Air intake temperature is outside of chassis operating range.
	Steady red	Air intake or exhaust temperature has reached critical limits.

**Table 2-2.** Main Chassis LED Behavior (Continued)

<b>LED</b>	<b>State</b>	<b>Description</b>
Fan Status	Off	Chassis is powered off.
	Steady green	All chassis fans are enabled and operating normally.
	Blinking red	One or more chassis fans have failed, but chassis can continue to operate.
	Steady red	One or more chassis fans have failed, and chassis must shut itself down.
Power Supply 1 Status	Off	Power supply is not installed or is in standby.
	Steady green	Power supply is active, and all voltages are within normal operating ranges.
	Blinking red	Power supply is active, and at least one voltage is out of range.
	Steady red	Power supply has failed.
Power Supply 2 Status	Off	Power supply is not installed or is in standby.
	Steady green	Power supply is active, and all voltages are within normal operating ranges.
	Blinking red	Power supply is active, and at least one voltage is out of range.
	Steady red	Power supply has failed.

Each chassis fan assembly has an LED that shows the current health of that fan. Table 2-3 describes the chassis fan LED behavior.

**Table 2-3.** Chassis Fan LED Behavior

<b>LED</b>	<b>State</b>	<b>Description</b>
Individual Fan Status	Off	Fan is not enabled.
	Steady green	Fan is operating normally.
	Steady red	Fan has failed.

Each power supply also has an LED that shows the power supply's current health. Table 2-4 describes the power supply LED behaviors.

**Table 2-4.** Power Supply LED Behavior

LEDs	State	Description
Individual Power Supply Status	Off	Power supply is in standby.
	Steady green	Power supply is operating normally.
	Steady red	Power supply has failed.

## Remote Inhibit and Fault Monitoring

The PXIe-1086 chassis supports remote inhibit and fault monitoring through a 4-pin terminal block on the chassis front panel. Refer to Figure 1-1, *Front View of the PXIe-1086 Chassis (with Optional Filler Panels)*, to locate this terminal block. Table 2-5 shows the terminal block pinout.

**Table 2-5.** Remote Inhibit and Fault Connector Pinout

Pin	Signal
1	Remote Inhibit (active low)
2	Ground
3	Remote Fault (active high)
4	Ground

When the chassis Inhibit Mode switch is in the Manual position, you can use the Remote Inhibit signal to control the chassis power supplies. Refer to *Inhibit Mode Switch* for more details.

The Remote Fault signal is an output signal that is asserted high when any chassis fault is detected. You can use this signal to monitor the overall chassis health.

## Inhibit Mode Switch

---

On the rear panel of the chassis there is an Inhibit Mode switch. Refer to Figure 1-2, [Rear View of the PXIe-1086 Chassis](#), for the location.

The Inhibit Mode switch should be in the **Default** position when normal power inhibit switch functionality is desired. If the user needs to power on a chassis without a system controller installed the switch should be in the **Manual** position.

When the Inhibit Mode switch is set to the **Manual** position, the power supplies are enabled, and you can use the Inhibit signal (active low) on pin 1 of the Remote Inhibit and Fault connector to power off the chassis. To power off the chassis remotely, connect the Inhibit pin (pin 1) to a Logic Ground pin (pin 2). As long as this connection exists, the chassis will remain off (standby); when you remove this connection, the chassis turns on.



**Note** For the Remote Inhibit signal to control the On/Off (standby) state of the chassis, the Inhibit Mode switch must be in the **Manual** position.

## PXI\_CLK10 Connectors

---

There are two SMA connectors on the front of the PXIe-1086 chassis for PXI\_CLK10. The connectors are labeled IN and OUT. You can use them for supplying the backplane with PXI\_CLK10 or routing the backplane's PXI\_CLK10 to another chassis. Refer to the [System Reference Clock](#) section of Chapter 1, [Getting Started](#), for details about these signals.

## PXI Express System Configuration with MAX

---

The PXI Platform Services software included with your chassis automatically identifies your PXI Express system components to generate a `pxiesys.ini` file. You can configure your entire PXI system and identify PXI-1 chassis through Measurement & Automation Explorer (MAX), included with your system controller. MAX creates the `pxiesys.ini` and `pxisys.ini` file, which define your PXI system parameters. MAX also provides an interface to route and reserve triggers so dynamic routing, through drivers such as DAQmx, avoids double-driving and potentially damaging trigger lines. For more information about routing and reserving PXI triggers, refer to KnowledgeBase **3TJDOND8** at [ni.com/support](http://ni.com/support).

The configuration steps for single or multiple-chassis systems are the same.



Figure 2-8. Multichassis Configuration in MAX

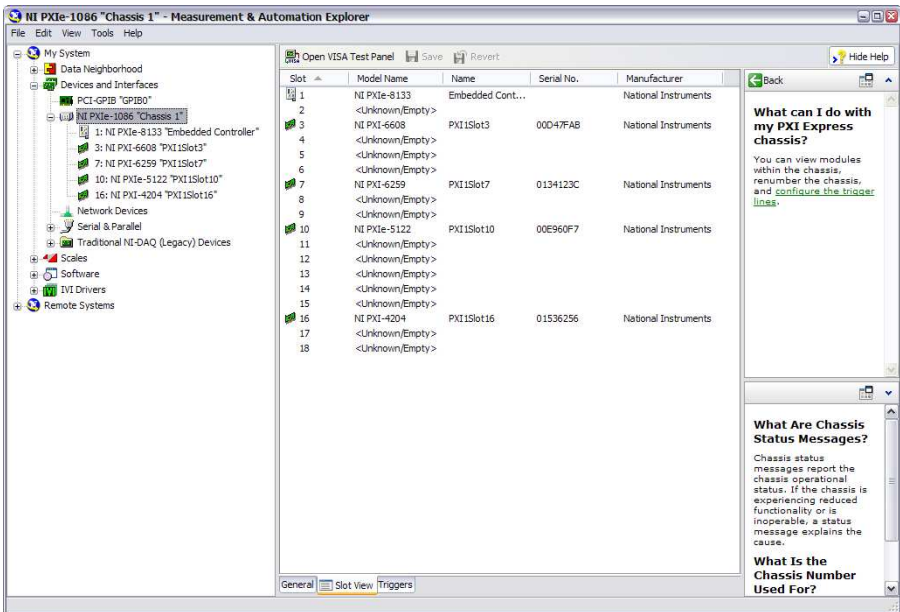

## PXI-1 System Configuration

1. Launch MAX.
2. In the **Configuration** tree, click the **Devices and Interfaces** branch to expand it.
3. If the PXI system controller has not yet been configured, it is labeled **PXI System (Unidentified)**. Right-click this entry to display the pop-up menu, then select the appropriate system controller model from the **Identify As** submenu.
4. Click the PXI system controller. The chassis (or multiple chassis, in a multichassis configuration) is listed below it. Identify each chassis by right-clicking its entry, then selecting the appropriate chassis model through the **Identify As** submenu. Further expanding the **PXI System** branch shows all devices in the system that can be recognized by NI-VISA. When your system controller and all your chassis are identified, the required `pxisys.ini` file is complete.

The PXI specification allows for many combinations of PXI chassis and system modules. To assist system integrators, the manufacturers of PXI chassis and system modules must document the capabilities of their products. PXI Express devices must provide a driver and `.ini` file for identification. These files are provided as part of the PXI Platform Services software included with your system controller. The minimum documentation requirements for PXI-1 are contained in `.ini` files, which consist of ASCII text. System integrators, configuration utilities, and device drivers can use these `.ini` files.

The capability documentation for a PXI-1 chassis is contained in a `chassis.ini` file provided by the chassis manufacturer. The information in this file is combined with information about the system controller to create a single PXI-1 system initialization file called `pxisys.ini` (PXI System Initialization). The NI system controller uses MAX to generate the `pxisys.ini` file from the `chassis.ini` file.

Device drivers and other utility software read the `pxiesys.ini` and `pxisys.ini` file to obtain system information. For detailed information about initialization files, refer to the PXI specification at [www.pxisa.org](http://www.pxisa.org).

## Trigger Configuration in MAX

Each chassis has one or more trigger buses, each with eight lines numbered 0 through 7 that can be reserved and routed statically or dynamically. Static reservation *pre-allocates* a trigger line to prevent its configuration by a user program. Dynamic reservation/routing/deallocation is *on the fly* within a user program based upon National Instruments APIs such as NI-DAQmx. Static reservation of trigger lines can be implemented by the user in MAX through the **Triggers** tab. Reserved trigger lines will not be used by PXI modules dynamically configured by programs such as NI-DAQmx. This prevents the instruments from double-driving the trigger lines, possibly damaging devices in the chassis. In the default configuration, trigger lines on each bus are independent. For example, if trigger line 3 is asserted on trigger bus 0, by default it will not be automatically asserted on any other trigger bus.

Complete the following steps to reserve these trigger lines in MAX.

1. In the Configuration tree, click on the PXI chassis branch you want to configure.
2. Then, in the right-hand pane, toward the bottom, click on the **Triggers** tab.
3. Select which trigger lines you would like to statically reserve.
4. Click the **Apply** button.

## PXI Trigger Bus Routing

The PXIe-1086 chassis can route triggers from one bus to others within the same chassis using the **Trigger Routing** tab in MAX, as shown in Figure 2-8.



**Note** Selecting any non-disabled routing automatically reserves the line in all trigger buses being routed to. If you are using NI-DAQmx, it will reserve and route trigger lines for you, so you won't have to route trigger lines manually.

Complete the following steps to configure trigger routings in MAX.

1. In the **Configuration** tree, select the chassis in which you want to route trigger lines.
2. In the right-hand pane, select the **Trigger Routing** tab near the bottom.
3. For each trigger line, select **Route Right**, **Route Outward From Middle**, or **Route Left** to route triggers on that line in the described direction, or select **Disabled** for the default behavior with no manual routing.
4. Click the **Apply** button.

# Using System Configuration and Initialization Files

---

The PXI Express specification allows many combinations of PXI Express chassis and system modules. To assist system integrators, the manufacturers of PXI Express chassis and system modules must document the capabilities of their products. The minimum documentation requirements are contained in `.ini` files, which consist of ASCII text. System integrators, configuration utilities, and device drivers can use these `.ini` files.

The capability documentation for the PXIe-1086 chassis is contained in the `chassis.ini` file on the software media that comes with the chassis. The information in this file is combined with information about the system controller to create a single system initialization file called `pxisys.ini` (PXI System Initialization). The system controller manufacturer either provides a `pxisys.ini` file for the particular chassis model that contains the system controller or provides a utility that can read an arbitrary `chassis.ini` file and generate the corresponding `pxisys.ini` file. System controllers from NI provide the `pxisys.ini` file for the PXIe-1086 chassis, so you should not need to use the `chassis.ini` file. Refer to the documentation provided with the system controller or to [ni.com/support](http://ni.com/support) for more information on `pxisys.ini` and `chassis.ini` files.

Device drivers and other utility software read the `pxisys.ini` file to obtain system information. The device drivers should have no need to directly read the `chassis.ini` file. For detailed information regarding initialization files, refer to the PXI Express specification at [www.pxisa.org](http://www.pxisa.org).

---

# Maintenance

This chapter describes basic maintenance procedures you can perform on the PXIe-1086 chassis.



**Caution** Disconnect the power cable prior to servicing a PXIe-1086 chassis.

---

## Service Interval

Clean dust from the chassis exterior (and interior) as needed, based on the operating environment. Periodic cleaning increases reliability.

---

## Preparation

The information in this section is designed for use by qualified service personnel. Read the *Read Me First: Safety and Electromagnetic Compatibility* document included with your kit before attempting any procedures in this chapter.



**Caution** Many components within the chassis are susceptible to static discharge damage. Service the chassis only in a static-free environment. Observe standard handling precautions for static-sensitive devices while servicing the chassis. *Always* wear a grounded wrist strap or equivalent while servicing the chassis.

---

## Cleaning

Cleaning procedures consist of exterior and interior cleaning of the chassis. Refer to your module user documentation for information on cleaning the individual CompactPCI or PXI Express modules.



**Caution** *Always* disconnect all power cables before cleaning or servicing the chassis.

## Interior Cleaning

Use a dry, low-velocity stream of air to clean the interior of the chassis. Use a soft-bristle brush for cleaning around components.

## Exterior Cleaning

Clean the exterior surfaces of the chassis with a dry lint-free cloth or a soft-bristle brush. If any dirt remains, wipe with a cloth moistened in a mild soap solution. Remove any soap residue by wiping with a cloth moistened with clear water. Do not use abrasive compounds on any part of the chassis.



**Caution** Avoid getting moisture inside the chassis during exterior cleaning, especially through the top vents. Use just enough moisture to dampen the cloth.



**Caution** Do *not* wash the front- or rear-panel connectors or switches. Cover these components while cleaning the chassis.



**Caution** Do *not* use harsh chemical cleaning agents; they may damage the chassis. Avoid chemicals that contain benzene, toluene, xylene, acetone, or similar solvents.

## Replacing a Modular Power Supply

---

This section describes how to remove and install a modular power supply for the PXIe-1086 chassis.



**Caution** Do not use a power supply from another chassis. Doing so may damage your chassis and the power supply. You *must* ensure the chassis is properly grounded after any maintenance. Refer to Chapter 2, [Connecting Safety Ground](#) and [Connecting to Power Source](#), for instructions on connecting safety ground.

## Removal

The PXIe-1086 power supply (part number 782106-01) is a replacement part for the PXIe-1086 chassis. Before attempting to replace a power supply, verify that there is adequate clearance behind the chassis.

The power supplies for this chassis are redundant and hot swappable. If both power supplies are installed and functional, you can remove either without disconnecting main AC power from the system. If both power supplies are installed, and one has failed, you can remove the failed supply without disconnecting main AC power from the system.

Complete the following steps to remove a power supply from the rear of the chassis, as shown in Figure 3-1:



**Caution** Before handling the power supply, allow the fan to stop spinning.

1. Disengage the two screws on the rear of the power supply with a flat-blade screwdriver.
2. Extend the collapsible handle and pull the power supply out of the chassis.

**Figure 3-1.** Removing Power Supply from PXIe-1086 Chassis

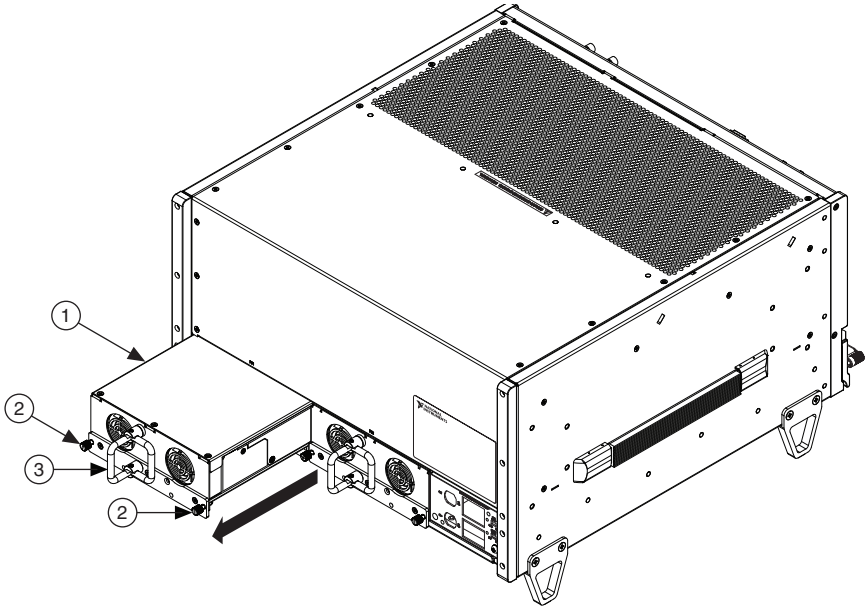

1 Power Supply

2 Captive Screw

3 Collapsible Handle

If access to the rear of the chassis is not available, you still can remove the power supplies by removing the entire power drawer from the chassis. The power drawer is shown in Figure 3-2.

**Figure 3-2.** PXIe-1086 Power Drawer

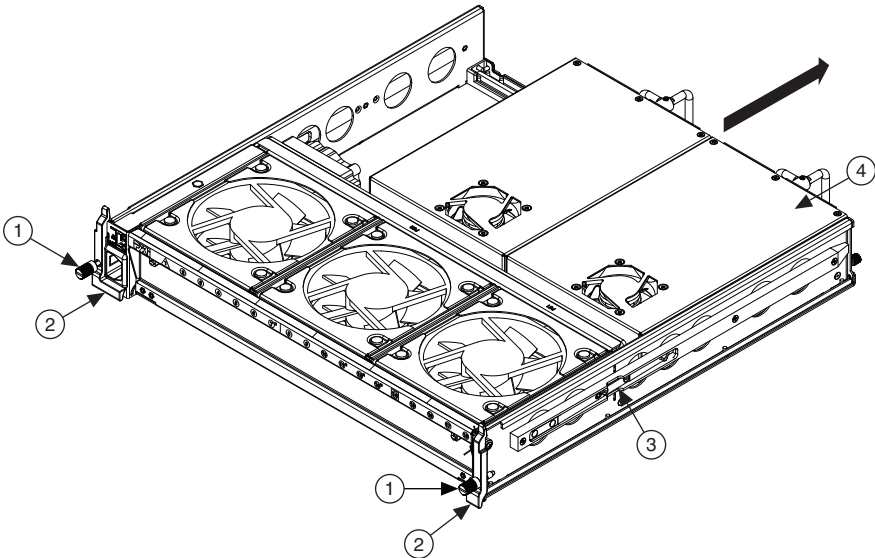

- |   |               |   |                    |   |            |   |              |
|---|---------------|---|--------------------|---|------------|---|--------------|
| 1 | Captive Screw | 2 | Power Drawer Lever | 3 | Side Latch | 4 | Power Supply |
|---|---------------|---|--------------------|---|------------|---|--------------|



**Note** If you are using the PXIe-1086 and NI SC Express modules with front mounting terminal blocks together, you must remove the SC Express module front mount terminal blocks to access the power drawer. Refer to your module documentation for more information about removing the terminal blocks.

Complete the following steps to remove the power drawer:

1. Loosen the drawer lever captive screws with a flat-blade screwdriver until the threads disengage from the chassis frame.
2. Rotate the drawer levers to eject the drawer from the chassis frame.
3. Pull the drawer about halfway out until the side latches engage.
4. Press in the side latches on both sides to release the drawer and continue to pull out the drawer.



**Caution** Before handling the power supply, allow the fan to stop spinning.

5. Place the drawer on a table surface to remove the power supply.

6. Disengage the two screws on the rear of the power supply with a flat-blade screwdriver. (Refer to Figure 3-1.)
7. Extend the collapsible handle and pull the power supply out of the chassis. (Refer to Figure 3-1.)

## Installation

Ensure there is no visible damage to the new power supply before installing it. Verify that there is no foreign material inside the connector on the new power supply.

The power supplies for this chassis are redundant and hot swappable. If one power supply already is installed and functional, you can install the second power supply without first disconnecting main AC power from the system. If no power supplies are installed or functional in the system, you must remove main power from the system by disconnecting the power cable from the AC power connector on the chassis front panel.

Complete the following steps to install a power supply from the rear of the chassis:

1. Slide the power supply into an empty slot with the connector facing toward the chassis until it engages.
2. Fold down the collapsible handle on the power supply.
3. Tighten the two captive screws on the rear of the power supply to 11.5 lb · in. torque with a flat-blade screwdriver.

If access to the rear of the chassis is not available, you still can install power supplies by removing the entire power drawer from the chassis. The power drawer is shown in Figure 3-2.



**Note** If you are using the PXIe-1086 and NI SC Express modules with front mounting terminal blocks together, you must remove the SC Express module front mount terminal blocks to access the power drawer. Refer to your module documentation for more information about removing the terminal blocks.

Complete the following steps to remove the power drawer:

1. Loosen the drawer lever captive screws with a flat-blade screwdriver until the threads disengage from the chassis frame.
2. Rotate the drawer levers to eject the drawer from the chassis frame.
3. Pull the drawer about halfway out until the side latches engage.
4. Press in the side latches on both sides to release the drawer and continue to pull out the drawer.



**Caution** Before handling the power supply, allow the fan to stop spinning.

5. Place the drawer on a table surface to install the power supply.
6. Slide the power supply into an empty slot with the connector facing toward inside of drawer until it engages.



7. Fold down the collapsible handle on the power supply.
8. Tighten the two captive screws on the rear of the power supply to 11.5 lb · in. torque with a flat-blade screwdriver.
9. Reinstall the power drawer. When reinstalling the drawer, tighten the drawer lever captive screws to 11.5 lb · in. torque.

## Replacing a Modular Fan Assembly

---

This section describes how to remove and install a modular fan assembly for the PXIe-1086 chassis.



**Caution** Do not use a fan assembly from another chassis. Doing so may damage your chassis and the fan assembly.

### Removal

The PXIe-1086 fan assembly (part number 782107-01) is a replacement part for the PXIe-1086 chassis. Before attempting to replace a fan assembly, verify that there is adequate clearance in front of the chassis.

The fans for this chassis are redundant and hot swappable. You can remove the fans with main AC power connected to the system.



**Caution** Use care when selecting which fans to remove, as an undesired system shut down can occur. Do not remove both fans from the same column, as this triggers a system shutdown.



**Caution** Likewise, do not remove the working fan from the same column as a failed fan, as this also triggers a chassis shutdown.



**Caution** If all fans are installed and operating normally, you can remove any fan without causing the system to shut down.

Figure 3-3 shows the PXIe-1086 chassis with a fan assembly removed.

**Figure 3-3.** PXIe-1086 Chassis with Fan Assembly Removed

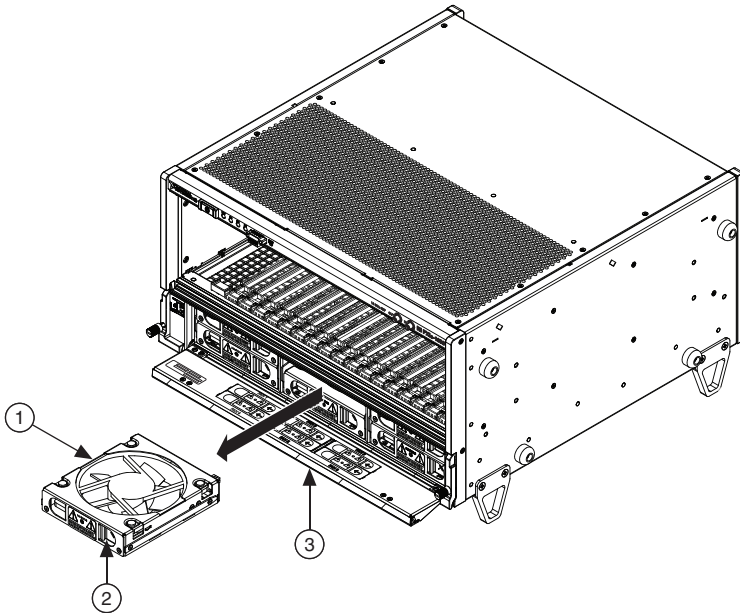

1 Modular Fan Assembly

2 Fan Latch

3 Fan Door

Complete the following steps to remove a fan assembly:

1. Open the fan door by sliding the door latches inward and rotating the door down.
2. Locate the fan to be removed. A red LED indicates a failed fan.



**Caution** If the fan is still spinning, allow the fan to stop before handling. (The fan will not stop as long as it is in the airflow path.)

3. Slide the fan latch until it disengages and allows removal by pulling the fan module forward.

## Installation

Ensure there is no visible damage to the new fan assembly before installing it. Verify that there is no foreign material inside the connector on the new fan assembly.

The fans for this chassis are redundant and hot swappable. You can install any fan with main AC power connected to the system.

Complete the following steps to install a fan assembly:

1. Open the fan door by sliding the door latches inward and rotating the door down.
2. Slide the fan module into an empty fan slot with the connector facing the chassis until it latches.
3. Verify that the fan is properly installed by pulling it forward with a light force without pressing the latch. If the fan does not slide out without pressing in the latch, it is installed correctly.
4. Close the fan door.

# Specifications

This appendix contains specifications for the PXIe-1086 chassis.



**Caution** Specifications are subject to change without notice.

## Electrical

Input voltage range .....	100 to 240 VAC
Operating voltage range <sup>1</sup> .....	90 to 264 VAC
Input current rating .....	12 to 6 A
Input frequency range .....	50/60 Hz
Operating frequency range <sup>1</sup> .....	47 to 63 Hz
Efficiency.....	70% typical
Power disconnect.....	The AC power cables provide main power disconnect. Do not position the equipment so that it is difficult to disconnect the power cord. The front panel power switch causes the internal chassis power supply to provide DC power to the CompactPCI/PXI Express backplane. You also can use the front panel terminal block 4-pin connector and power mode switch to control the internal chassis power supply.

## DC Output

DC current capacity ( $I_{MP}$ )

Voltage	Maximum Current Single Power Supply	Maximum Current Dual Power Supplies
+3.3 V	50 A	60 A
+5 V	40 A	49 A
+12 V	50 A	62 A
-12 V	4 A	4 A
5 V <sub>AUX</sub>	1.5 A	1.5 A

<sup>1</sup> This operating range is guaranteed by design.



**Note** Maximum combined +12 V and -12 V power of a single power supply is 588 W.



**Note** Maximum total available power of a single power supply is 855 W.

Backplane slot current capacity

Slot	+5 V	V (I/O)	+3.3 V	+12 V	-12 V	5 V <sub>AUX</sub>
System Controller Slot	15 A	—	15 A	30 A	—	1 A
System Timing Slot	—	—	6 A	4 A	—	1 A
Hybrid Peripheral Slot with PXI-1 Peripheral	6 A	5 A	6 A	1 A	1 A	—
Hybrid Peripheral Slot with PXI-5 Peripheral	—	—	6 A	4 A	—	1 A
PXI-1 Peripheral Slot	6 A	11 A	6 A	1 A	1 A	—



**Note** Total system slot current should not exceed 45 A.



**Note** PCI V(I/O) pins in PXI-1 peripheral slots and hybrid peripheral slots are connected to +5 V.



**Note** The maximum power dissipated in the system slot should not exceed 140 W.



**Note** The maximum power dissipated in a peripheral slot should not exceed 38.25 W.

Load regulation

Voltage	Load Regulation
+3.3 V	<5%
+12 V	<5%
+5 V	<5%
-12 V	<5%

Maximum ripple and noise (20 MHz bandwidth)

Voltage	Maximum Ripple and Noise
+3.3 V	50 mV <sub>pp</sub>
+12 V	120 mV <sub>pp</sub>
+5 V	50 mV <sub>pp</sub>
-12 V	120 mV <sub>pp</sub>

- Over-current protection ..... All outputs protected from short circuit and overload with automatic recovery
- Over-voltage protection, 3.3 V and 5 V ..... Clamped at 25 to 40% above nominal output voltage
- Power supply MTTR ..... Replacement in under 1 minute

## Chassis Cooling

- Module cooling system..... Forced air circulation (positive pressurization) through six 150 cfm fans (three sets of dual stacked fans) with High/Auto speed selector.
- Slot airflow direction ..... Bottom of module to top of module
- Module cooling intake ..... Bottom of chassis
- Module cooling exhaust..... Along top of chassis
- Power supply cooling system ..... Forced air circulation through integrated fan
- Power supply cooling intake..... Rear of chassis
- Power supply cooling exhaust ..... Top of chassis

## Environmental

- Maximum altitude..... 4600 m (570 mbar) (at 25 °C ambient)



**Note** Fan speed selector must be set to High to meet the maximum altitude specification.

- Pollution Degree ..... 2
- For indoor use only.

## Operating Environment

- Ambient temperature range ..... 0 to 50 °C  
(Tested in accordance with IEC 60068-2-1 and IEC 60068-2-2. Meets MIL-PRF-28800F Class 3 temperature limits.)

Relative humidity range..... 5 to 95%, noncondensing  
(Tested to temperature and humidity levels specified in MIL-PRF-28800F)

## Storage Environment

Ambient temperature range ..... -40 to 71 °C  
(Tested in accordance with IEC 60068-2-1 and IEC 60068-2-2. Meets MIL-PRF-28800F Class 3 temperature limits.)

Relative humidity range..... 5 to 95%, noncondensing  
(Tested in accordance with IEC 60068-2-56.)

## Shock and Vibration

Operational shock ..... 30 g peak, half-sine, 11 ms pulse  
(Tested in accordance with IEC 60068-2-27. Meets MIL-PRF-28800F Class 2 limits.)

### Random Vibration

Operating ..... 5 to 500 Hz, 0.3 g<sub>rms</sub>



**Caution** When using a single power supply unit, you must use a power supply filler panel (NI P/N 784057-01) in the empty slot to meet operational shock and vibration specifications.

## Acoustic Emissions

### Sound Pressure Level (at Operator Position)

(Tested in accordance with ISO 7779. Meets MIL-PRF-28800F requirements.)

Auto fan (up to ~30 °C ambient) ..... 57.0 dBA  
High fan ..... 69.0 dBA

### Sound Power

Auto fan (up to ~30 °C ambient) ..... 63.3 dBA  
High fan ..... 79.3 dBA



**Caution** The protection provided by the PXIe-1086 can be impaired if it is used in a manner not described in this document.

## Safety

This product is designed to meet the requirements of the following standards of safety for information technology equipment:

- IEC 61010-1, EN 61010-1
- UL 61010-1, CSA 61010-1



**Note** For UL and other safety certifications, refer to the product label or the [Online Product Certification](#) section.

## Electromagnetic Compatibility

This product meets the requirements of the following EMC standards for electrical equipment for measurement, control, and laboratory use:

- EN 61326-1 (IEC 61326-1): Class A emissions; Basic immunity
- EN 55011 (CISPR 11): Group 1, Class A emissions
- AS/NZS CISPR 11: Group 1, Class A emissions
- FCC 47 CFR Part 15B: Class A emissions
- ICES-001: Class A emissions



**Note** In the United States (per FCC 47 CFR), Class A equipment is intended for use in commercial, light industrial, and heavy industrial locations. In Europe, Canada, Australia, and New Zealand (per CISPR 11), Class A equipment is intended for use only in heavy industrial locations.



**Note** Group 1 equipment (per CISPR 11) is any industrial, scientific, or medical equipment that does not intentionally generate radio frequency energy for the treatment of material or inspection/analysis purposes.



**Note** For EMC declarations and certifications and additional information, refer to the [Online Product Certification](#) section.

## CE Compliance

This product meets the essential requirements of applicable European Directives as follows:

- 2014/35/EC; Low-Voltage Directive (safety)
- 2014/13/EC; Electromagnetic Compatibility Directive (EMC)



## Online Product Certification

Refer to the product Declaration of Conformity (DoC) for additional regulatory compliance information. To obtain product certifications and the DoC for this product, visit [ni.com/certification](http://ni.com/certification), search by model number or product line, and click the appropriate link in the Certification column.

## Environmental Management

NI is committed to designing and manufacturing products in an environmentally responsible manner. NI recognizes that eliminating certain hazardous substances from our products is beneficial to the environment and to NI customers.

For additional environmental information, refer to the *Minimize Our Environmental Impact* web page at [ni.com/environment](http://ni.com/environment). This page contains the environmental regulations and directives with which NI complies, as well as other environmental information not included in this document.

## Waste Electrical and Electronic Equipment (WEEE)



**EU Customers** At the end of the product life cycle, all products *must* be sent to a WEEE recycling center. For more information about WEEE recycling centers, National Instruments WEEE initiatives, and compliance with WEEE Directive 2002/96/EC on Waste and Electronic Equipment, visit [ni.com/environment/weee](http://ni.com/environment/weee).

## 电子信息产品污染控制管理办法（中国 RoHS）



**中国客户** National Instruments 符合中国电子信息产品中限制使用某些有害物质指令 (RoHS)。关于 National Instruments 中国 RoHS 合规性信息, 请登录 [ni.com/environment/rohs\\_china](http://ni.com/environment/rohs_china)。(For information about China RoHS compliance, go to [ni.com/environment/rohs\\_china](http://ni.com/environment/rohs_china).)

## Backplane

Size.....	3U-sized; one system slot (with three system expansion slots) and 17 peripheral slots. Compliant with IEEE 1101.10 mechanical packaging. PXI Express Specification compliant. Accepts both PXI Express and CompactPCI (PICMG 2.0 R 3.0) 3U modules.
Backplane bare-board material .....	UL 94 V-0 Recognized
Backplane connectors .....	Conforms to IEC 917 and IEC 1076-4-101, and are UL 94 V-0 rated

## System Synchronization Clocks (PXI\_CLK10, PXIe\_CLK100, PXIe\_SYNC100)

### 10 MHz System Reference Clock: PXI\_CLK10

Maximum slot-to-slot skew .....	1 ns
Accuracy .....	±25 ppm max. (guaranteed over the operating temperature range)
Maximum jitter .....	5 ps RMS phase-jitter (10 Hz to 1 MHz range)
Duty-factor .....	45% to 55%
Unloaded signal swing .....	3.3 V ±0.3 V



**Note** For other specifications, refer to the *PXI-1 Hardware Specification*.

### 100 MHz System Reference Clock: PXIe\_CLK100 and PXIe\_SYNC100

Maximum slot-to-slot skew .....	100 ps
Accuracy .....	±25 ppm max. (guaranteed over the operating temperature range)
Maximum jitter .....	3 ps RMS phase-jitter (10 Hz to 12 kHz range) 2 ps RMS phase-jitter (12 kHz to 20 MHz range)
Duty-factor for PXIe_CLK100 .....	45% to 55%
Absolute single-ended voltage swing (When each line in the differential pair has 50 W termination to 1.30 V or Thévenin equivalent) .....	400 to 1000 mV



**Note** For other specifications, refer to the *PXI-5 PXI Express Hardware Specification*.

### External 10 MHz Reference Out (SMA on front panel of chassis)

Accuracy .....	±25 ppm max. (guaranteed over the operating temperature range)
Maximum jitter .....	5 ps RMS phase-jitter (10 Hz to 1 MHz range)
Output amplitude .....	1 V <sub>pp</sub> ±20% square-wave into 50 Ω 2 V <sub>pp</sub> unloaded
Output impedance .....	50 Ω ±5 Ω

## External Clock Source

Frequency.....	10 MHz $\pm$ 100 PPM
Input amplitude	
Front-panel SMA .....	200 mV <sub>pp</sub> to 5 V <sub>pp</sub> square-wave or sine-wave
System timing slot	
PXI_CLK10_IN.....	5 V or 3.3 V TTL signal
Front-panel SMA input impedance.....	50 $\Omega$ $\pm$ 5 $\Omega$
Maximum jitter introduced	
by backplane .....	1 ps RMS phase-jitter (10 Hz to 1 MHz range)

## PXle\_SYNC\_CTRL

V <sub>IH</sub> .....	2.0 to 5.5 V
V <sub>IL</sub> .....	0 to 0.8 V

## PXI Star Trigger

Maximum slot-to-slot skew .....	250 ps
Backplane characteristic impedance.....	65 $\Omega$ $\pm$ 10%



**Note** For PXI slot to PXI Star mapping refer to the *System Timing Slot* section of Chapter 1, *Getting Started*.

For other specifications refer to the *PXI-1 Hardware Specification*.

## PXI Differential Star Triggers (PXle-DSTARA, PXle-DSTARB, PXle-DSTARC)

Maximum slot-to-slot skew .....	150 ps
Maximum differential skew .....	25 ps
Backplane differential impedance.....	100 $\Omega$ $\pm$ 10%



**Note** For PXI Express slot to PXI\_DSTAR mapping refer to the *System Timing Slot* section of Chapter 1, *Getting Started*.

For other specifications, the PXIe-1086 complies with the *PXI-5 PXI Express Hardware Specification*.

## Mechanical

### Overall dimensions, standard chassis

Height .....	10.59 in. (268.7 mm)
Width .....	18.39 in. (467.1 mm)
Depth .....	18.76 in. (476.5 mm)



**Note** 1.84 in. (46.8 mm) is added to height when feet are installed.

### Weight

With two power supplies .....	37.6 lb (17.1 kg)
With single power supply .....	31.5 lb (14.3 kg)

Chassis materials ..... Sheet Aluminum (5052-H32, 3003-H14, and 6061-T6), Extruded Aluminum (6060-T6), and Cold Rolled Steel, PC-ABS, Santoprene, Nylon

Finish ..... Conductive Clear Iridite on Aluminum  
Electroplated Nickel  
on Cold Rolled Steel  
Polyurethane Enamel

Figures A-1 and A-2 show the PXIe-1086 chassis dimensions. The holes shown are for the installation of the optional rack mount kits. You can install those kits on the front or rear of the chassis, depending on which end of the chassis you want to face toward the front of the instrument cabinet. Notice that the front and rear chassis mounting holes (size M4) are symmetrical.

**Figure A-1. NI PXIe-1086 Chassis Dimensions (Front and Side)**

Dimensions are in inches (millimeters)

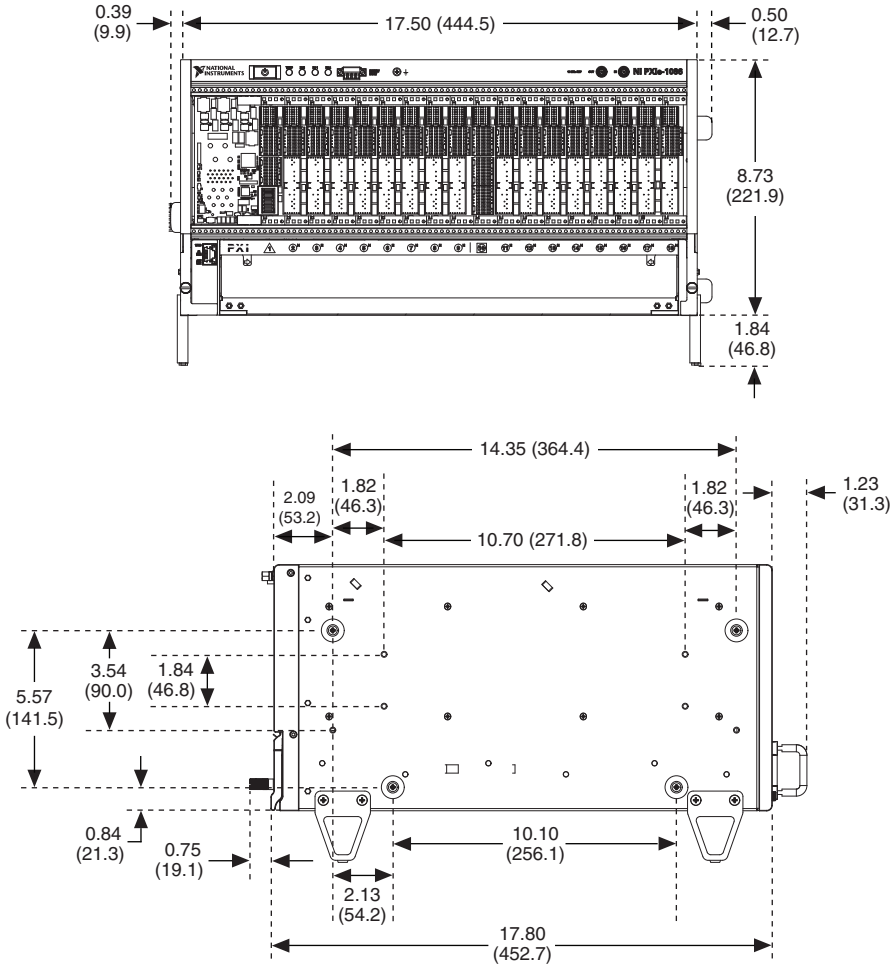

**Figure A-2. NI PXIe-1086 Chassis Dimensions (Bottom)**

Dimensions are in inches (millimeters)

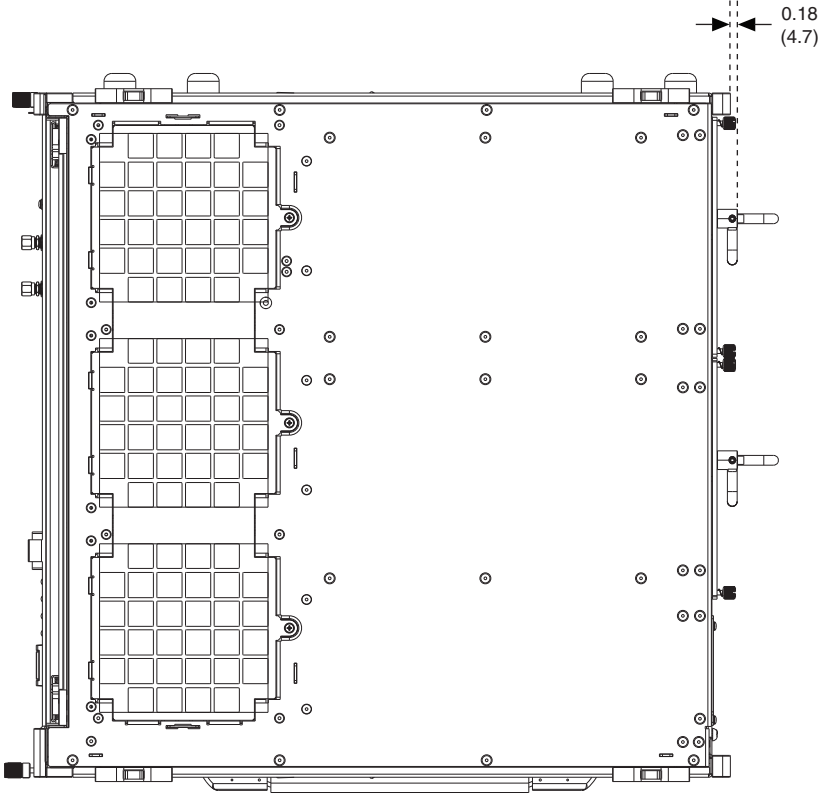
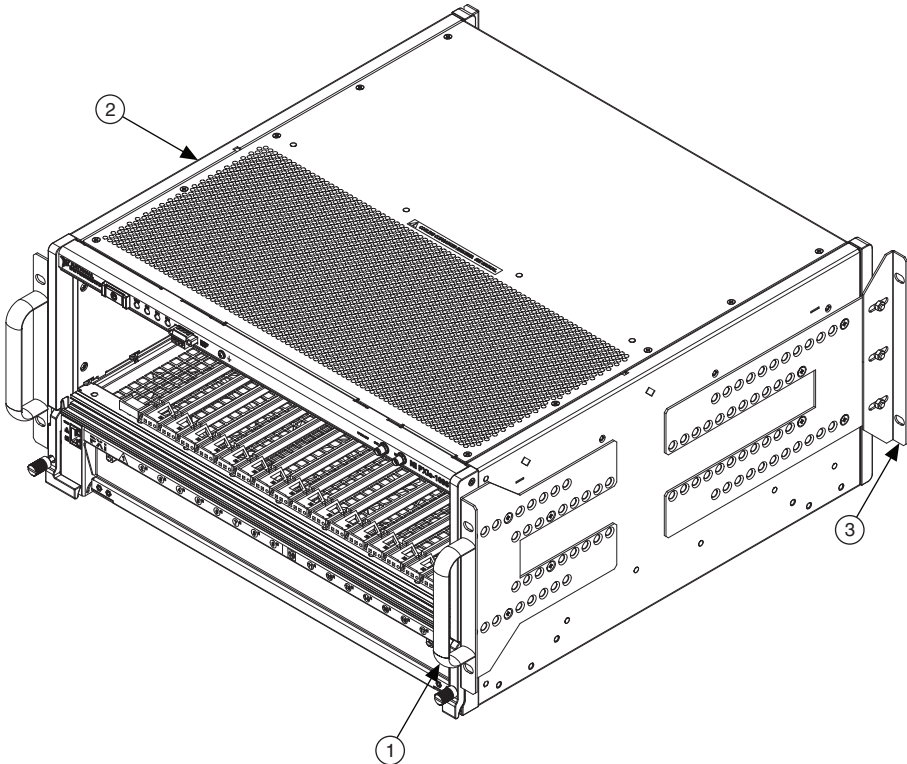

Figure A-3 shows the chassis rack mount kit components.

**Figure A-3.** NI Chassis Rack Mount Kit Components



1 Front Rack Mount Kit

2 NI Chassis

3 Optional Rear Rack Mount Kit



**Note** For more information about rack mounting the PXIe-1086 chassis, refer to the printed installation guide included with your rack mount kit.

---

# Pinouts

This appendix describes the connector pinouts for the PXIe-1086 chassis backplane.

Table B-1 shows the XP1 connector pinout for the System Controller slot.

Table B-2 shows the XP2 connector pinout for the System Controller slot.

Table B-3 shows the XP3 connector pinout for the System Controller slot.

Table B-4 shows the XP4 connector pinout for the System Controller slot.

Table B-5 shows the TP1 connector pinout for the System Controller slot.

Table B-6 shows the TP2 connector pinout for the System Timing slot.

Table B-7 shows the XP3 connector pinout for the System Timing slot.

Table B-8 shows the XP4 connector pinout for the System Timing slot.

Table B-9 shows the P1 connector pinout for the peripheral slots.

Table B-10 shows the P2 connector pinout for the peripheral slots.

Table B-11 shows the P1 connector pinout for the Hybrid peripheral slots.

Table B-12 shows the XP3 connector pinout for the Hybrid peripheral slots.

Table B-13 shows the XP4 connector pinout for the Hybrid peripheral slots.

For more detailed information, refer to the *PXI-5 PXI Express Hardware Specification*, Revision 2.0. Contact the PXI Systems Alliance for a copy of the specification.



# System Controller Slot Pinouts

**Table B-1.** XP1 Connector Pinout for the System Controller Slot

Pins	Signals
A	GND
B	12V
C	12V
D	GND
E	5V
F	3.3V
G	GND

**Table B-2.** XP2 Connector Pinout for the System Controller Slot

Pin	A	B	ab	C	D	cd	E	F	ef
1	3PETp1	3PETn1	GND	3PERp1	3PERn1	GND	3PETp2	3PETn2	GND
2	3PETp3	3PETn3	GND	3PERp3	3PERn3	GND	3PERp2	3PERn2	GND
3	4PETp0	4PETn0	GND	4PERp0	4PERn0	GND	4PETp1	4PETn1	GND
4	4PETp2	4PETn2	GND	4PERp2	4PERn2	GND	4PERp1	4PERn1	GND
5	4PETp3	4PETn3	GND	4PERp3	4PERn3	GND	RSV	RSV	GND
6	RSV	RSV	GND	RSV	RSV	GND	RSV	RSV	GND
7	RSV	RSV	GND	RSV	RSV	GND	RSV	RSV	GND
8	RSV	RSV	GND	RSV	RSV	GND	RSV	RSV	GND
9	RSV	RSV	GND	RSV	RSV	GND	RSV	RSV	GND
10	RSV	RSV	GND	RSV	RSV	GND	RSV	RSV	GND

**Table B-3.** XP3 Connector Pinout for the System Controller Slot

Pin	A	B	ab	C	D	cd	E	F	ef
1	RSV	RSV	GND	RSV	RSV	GND	RSV	RSV	GND
2	RSV	RSV	GND	PWR_OK	PS_ON#	GND	LINKCAP	PWRBTN#	GND
3	SMBDAT	SMBCLK	GND	4RefClk+	4RefClk-	GND	2RefClk+	2RefClk-	GND
4	RSV	PERST#	GND	3RefClk+	3RefClk-	GND	1RefClk+	1RefClk-	GND
5	1PETp0	1PETn0	GND	1PERp0	1PERn0	GND	1PETp1	1PETn1	GND
6	1PETp2	1PETn2	GND	1PERp2	1PERn2	GND	1PERp1	1PERn1	GND
7	1PETp3	1PETn3	GND	1PERp3	1PERn3	GND	2PETp0	2PETn0	GND
8	2PETp1	2PETn1	GND	2PERp1	2PERn1	GND	2PERp0	2PERn0	GND
9	2PETp2	2PETn2	GND	2PERp2	2PERn2	GND	2PETp3	2PETn3	GND
10	3PETp0	3PETn0	GND	3PERp0	3PERn0	GND	2PERp3	2PERn3	GND

**Table B-4.** XP4 Connector Pinout for the System Controller Slot

Pin	Z	A	B	C	D	E	F
1	GND	GA4	GA3	GA2	GA1	GA0	GND
2	GND	5Vaux	GND	SYSEN#	WAKE#	ALERT#	GND
3	GND	RSV	RSV	RSV	RSV	RSV	GND
4	GND	RSV	RSV	RSV	RSV	RSV	GND
5	GND	PXI_TRIG3	PXI_TRIG4	PXI_TRIG5	GND	PXI_TRIG6	GND
6	GND	PXI_TRIG2	GND	RSV	PXI_STAR	PXI_CLK10	GND
7	GND	PXI_TRIG1	PXI_TRIG0	RSV	GND	PXI_TRIG7	GND
8	GND	RSV	GND	RSV	RSV	PXI_LBR6	GND

# System Timing Slot Pinouts

**Table B-5.** TP1 Connector Pinout for the System Timing Slot

Pin	A	B	ab	C	D	cd	E	F	ef
1	PXIe_ DSTARA3+	PXIe_ DSTARA3-	GND	NC	NC	GND	NC	NC	GND
2	PXIe_ DSTARC4+	PXIe_ DSTARC4-	GND	PXI_ STAR12	PXI_ STAR13	GND	NC	NC	GND
3	PXIe_ DSTARB4+	PXIe_ DSTARB4-	GND	NC	NC	GND	NC	NC	GND
4	PXIe_ DSTARA4+	PXIe_ DSTARA4-	GND	NC	NC	GND	NC	NC	GND
5	PXIe_ DSTARC5+	PXIe_ DSTARC5-	GND	PXI_ STAR14	PXI_ STAR15	GND	NC	NC	GND
6	PXIe_ DSTARB5+	PXIe_ DSTARB5-	GND	NC	NC	GND	NC	NC	GND
7	PXIe_ DSTARA5+	PXIe_ DSTARA5-	GND	NC	NC	GND	NC	NC	GND
8	PXIe_ DSTARC6+	PXIe_ DSTARC6-	GND	PXI_ STAR16	RSV	GND	NC	NC	GND
9	PXIe_ DSTARB6+	PXIe_ DSTARB6-	GND	NC	NC	GND	NC	NC	GND
10	PXIe_ DSTARA6+	PXIe_ DSTARA6-	GND	NC	NC	GND	NC	NC	GND

**Table B-6.** TP2 Connector Pinout for the System Timing Slot

Pin	A	B	ab	C	D	cd	E	F	ef
1	NC	NC	GND	PXIe_DSTAR C8+	PXIe_DSTAR C8-	GND	PXIe_DSTAR B8+	PXIe_DSTAR B8-	GND
2	NC	NC	GND	NC	NC	GND	PXIe_DSTAR A8+	PXIe_DSTAR A8-	GND
3	NC	NC	GND	PXIe_DSTAR C1+	PXIe_DSTAR C1-	GND	NC	NC	GND
4	PXIe_DSTAR B1+	PXIe_DSTAR B1-	GND	PXI_STAR0	PXI_STAR1	GND	NC	NC	GND
5	PXIe_DSTAR A1+	PXIe_DSTAR A1-	GND	PXI_STAR2	PXI_STAR3	GND	NC	NC	GND
6	PXIe_DSTAR C2+	PXIe_DSTAR C2-	GND	PXI_STAR4	PXI_STAR5	GND	NC	NC	GND
7	PXIe_DSTAR B2+	PXIe_DSTAR B2-	GND	PXI_STAR6	PXI_STAR7	GND	NC	NC	GND
8	PXIe_DSTAR A2+	PXIe_DSTAR A2-	GND	PXI_TAR8	PXI_STAR9	GND	PXIe_DSTAR C11+	PXIe_DSTAR C11-	GND
9	PXIe_DSTAR C3+	PXIe_DSTAR C3-	GND	PXI_STAR10	PXI_STAR11	GND	PXIe_DSTAR A11+	PXIe_DSTAR A11-	GND
10	PXIe_DSTAR B3+	PXIe_DSTAR B3-	GND	NC	NC	GND	PXIe_DSTAR B11+	PXIe_DSTAR B11-	GND

**Table B-7.** XP3 Connector Pinout for the System Timing Slot

Pin	A	B	ab	C	D	cd	E	F	ef
1	PXIe_CLK 100+	PXIe_CLK 100-	GND	PXIe_SYNC 100+	PXIe_SYNC 100-	GND	PXIe_DSTAR C+	PXIe_DSTAR C-	GND
2	PRSNT#	PWREN#	GND	PXIe_DSTAR B+	PXIe_DSTAR B-	GND	PXIe_DSTAR A+	PXIe_DSTAR A-	GND
3	SMB DAT	SMB CLK	GND	RSV	RSV	GND	RSV	RSV	GND

**Table B-7.** XP3 Connector Pinout for the System Timing Slot (Continued)

Pin	A	B	ab	C	D	cd	E	F	ef
4	MPWR GD*	PERST#	GND	RSV	RSV	GND	1RefClk+	1RefClk-	GND
5	1PETp0	1PETn0	GND	1PERp0	1PERn0	GND	1PETp1	1PETn1	GND
6	1PETp2	1PETn2	GND	1PERp2	1PERn2	GND	1PERp1	1PERn1	GND
7	1PETp3	1PETn3	GND	1PERp3	1PERn3	GND	1PETp4	1PETn4	GND
8	1PETp5	1PETn5	GND	1PERp5	1PERn5	GND	1PERp4	1PERn4	GND
9	1PETp6	1PETn6	GND	1PERp6	1PERn6	GND	1PETp7	1PETn7	GND
10	RSV	RSV	GND	RSV	RSV	GND	1PERp7	1PERn7	GND

**Table B-8.** XP4 Connector Pinout for the System Timing Slot

Pin	Z	A	B	C	D	E	F
1	GND	GA4	GA3	GA2	GA1	GA0	GND
2	GND	5Vaux	GND	SYSEN#	WAKE#	ALERT#	GND
3	GND	12V	12V	GND	GND	GND	GND
4	GND	GND	GND	3.3V	3.3V	3.3V	GND
5	GND	PXI_TRIG3	PXI_ TRIG4	PXI_ TRIG5	GND	PXI_ TRIG6	GND
6	GND	PXI_TRIG2	GND	ATNLED	PXI_CLK10_IN	PXI_ CLK10	GND
7	GND	PXI_TRIG1	PXI_ TRIG0	ATNSW#	GND	PXI_ TRIG7	GND
8	GND	PXIe_SYNC_ CTRL	GND	RSV	PXI_LBL6	PXI_ LBR6	GND

# Peripheral Slot Pinouts

**Table B-9. P1 Connector Pinout for the Peripheral Slot**

Pin	Z	A	B	C	D	E	F
25	GND	5V	REQ64#	ENUM#	3.3V	5V	GND
24	GND	AD[1]	5V	V(I/O)	AD[0]	ACK64#	GND
23	GND	3.3V	AD[4]	AD[3]	5V	AD[2]	GND
22	GND	AD[7]	GND	3.3V	AD[6]	AD[5]	GND
21	GND	3.3V	AD[9]	AD[8]	M66EN	C/BE[0]#	GND
20	GND	AD[12]	GND	V(I/O)	AD[11]	AD[10]	GND
19	GND	3.3V	AD[15]	AD[14]	GND	AD[13]	GND
18	GND	SERR#	GND	3.3V	PAR	C/BE[1]#	GND
17	GND	3.3V	IPMB_SCL	IPMB_SDA	GND	PERR#	GND
16	GND	DEVSEL#	GND	V(I/O)	STOP#	LOCK#	GND
15	GND	3.3V	FRAME#	IRDY#	BD_SEL#	TRDY#	GND
12 to 14	Key Area						
11	GND	AD[18]	AD[17]	AD[16]	GND	C/BE[2]#	GND
10	GND	AD[21]	GND	3.3V	AD[20]	AD[19]	GND
9	GND	C/BE[3]#	IDSEL	AD[23]	GND	AD[22]	GND
8	GND	AD[26]	GND	V(I/O)	AD[25]	AD[24]	GND
7	GND	AD[30]	AD[29]	AD[28]	GND	AD[27]	GND
6	GND	REQ#	GND	3.3V	CLK	AD[31]	GND
5	GND	BRSVP1A5	BRSVP1B5	RST#	GND	GNT#	GND
4	GND	IPMB_PWR	HEALTHY	V(I/O)	INTP	INTS	GND
3	GND	INTA#	INTB#	INTC#	5V	INTD#	GND
2	GND	TCK	5V	TMS	TDO	TDI	GND
1	GND	5V	-12V	TRST#	+12V	5V	GND

**Table B-10.** P2 Connector Pinout for the Peripheral Slot

Pin	Z	A	B	C	D	E	F
22	GND	GA4	GA3	GA2	GA1	GA0	GND
21	GND	PXI_LBR0	GND	PXI_LBR1	PXI_LBR2	PXI_LBR3	GND
20	GND	PXI_LBR4	PXI_LBR5	PXI_LBL0	GND	PXI_LBL1	GND
19	GND	PXI_LBL2	GND	PXI_LBL3	PXI_LBL4	PXI_LBL5	GND
18	GND	PXI_TRIG3	PXI_TRIG4	PXI_TRIG5	GND	PXI_TRIG6	GND
17	GND	PXI_TRIG2	GND	RSV	PXI_STAR	PXI_CLK10	GND
16	GND	PXI_TRIG1	PXI_TRIG0	RSV	GND	PXI_TRIG7	GND
15	GND	PXI_BRSPA15	GND	RSV	PXI_LBL6	PXI_LBR6	GND
14	GND	RSV	RSV	RSV	GND	RSV	GND
13	GND	RSV	GND	V(I/O)	RSV	RSV	GND
12	GND	RSV	RSV	RSV	GND	RSV	GND
11	GND	RSV	GND	V(I/O)	RSV	RSV	GND
10	GND	RSV	RSV	RSV	GND	RSV	GND
9	GND	RSV	GND	V(I/O)	RSV	RSV	GND
8	GND	RSV	RSV	RSV	GND	RSV	GND
7	GND	RSV	GND	V(I/O)	RSV	RSV	GND
6	GND	RSV	RSV	RSV	GND	RSV	GND
5	GND	RSV	GND	V(I/O)	RSV	RSV	GND
4	GND	V(I/O)	64EN#	RSV	GND	RSV	GND
3	GND	PXI_LBR7	GND	PXI_LBR8	PXI_LBR9	PXI_LBR10	GND
2	GND	PXI_LBR11	PXI_LBR12	UNC	PXI_LBL7	PXI_LBL8	GND
1	GND	PXI_LBL9	GND	PXI_LBL10	PXI_LBL11	PXI_LBL12	GND

# Hybrid Slot Pinouts

**Table B-11. P1 Connector Pinout for the Hybrid Slot**

Pin	Z	A	B	C	D	E	F
25	GND	5V	REQ64#	ENUM#	3.3V	5V	GND
24	GND	AD[1]	5V	V(I/O)	AD[0]	ACK64#	GND
23	GND	3.3V	AD[4]	AD[3]	5V	AD[2]	GND
22	GND	AD[7]	GND	3.3V	AD[6]	AD[5]	GND
21	GND	3.3V	AD[9]	AD[8]	M66EN	C/BE[0]#	GND
20	GND	AD[12]	GND	V(I/O)	AD[11]	AD[10]	GND
19	GND	3.3V	AD[15]	AD[14]	GND	AD[13]	GND
18	GND	SERR#	GND	3.3V	PAR	C/BE[1]#	GND
17	GND	3.3V	IPMB_SCL	IPMB_SDA	GND	PERR#	GND
16	GND	DEVSEL#	GND	V(I/O)	STOP#	LOCK#	GND
15	GND	3.3V	FRAME#	IRDY#	BD_SEL#	TRDY#	GND
12 to 14	Key Area						
11	GND	AD[18]	AD[17]	AD[16]	GND	C/BE[2]#	GND
10	GND	AD[21]	GND	3.3V	AD[20]	AD[19]	GND
9	GND	C/BE[3]#	IDSEL	AD[23]	GND	AD[22]	GND
8	GND	AD[26]	GND	V(I/O)	AD[25]	AD[24]	GND
7	GND	AD[30]	AD[29]	AD[28]	GND	AD[27]	GND
6	GND	REQ#	GND	3.3V	CLK	AD[31]	GND
5	GND	BRSVP1A5	BRSVP1B5	RST#	GND	GNT#	GND
4	GND	IPMB_PWR	HEALTHY#	V(I/O)	INTP	INTS	GND
3	GND	INTA#	INTB#	INTC#	5V	INTD#	GND
2	GND	TCK	5V	TMS	TDO	TDI	GND
1	GND	5V	-12V	TRST#	+12V	5V	GND



**Table B-12. XP3 Connector Pinout for the Hybrid Slot**

Pin	A	B	ab	C	D	cd	E	F	ef
1	PXIe_CLK100+	PXIe_CLK100-	GND	PXIe_SYNC100+	PXIe_SYNC100-	GND	PXIe_DSTARC+	PXIe_DSTARC-	GND
2	PRSNT#	PWREN#	GND	PXIe_DSTARB+	PXIe_DSTARB-	GND	PXIe_DSTARA+	PXIe_DSTARA-	GND
3	SMB DAT	SMB CLK	GND	RSV	RSV	GND	RSV	RSV	GND
4	MPWR GD*	PERST#	GND	RSV	RSV	GND	1RefClk+	1RefClk-	GND
5	1PETp0	1PETn0	GND	1PERp0	1PERn0	GND	1PETp1	1PETn1	GND
6	1PETp2	1PETn2	GND	1PERp2	1PERn2	GND	1PERp1	1PERn1	GND
7	1PETp3	1PETn3	GND	1PERp3	1PERn3	GND	1PETp4	1PETn4	GND
8	1PETp5	1PETn5	GND	1PERp5	1PERn5	GND	1PERp4	1PERn4	GND
9	1PETp6	1PETn6	GND	1PERp6	1PERn6	GND	1PETp7	1PETn7	GND
10	RSV	RSV	GND	RSV	RSV	GND	1PERp7	1PERn7	GND

**Table B-13. XP4 Connector Pinout for the Hybrid Slot**

Pin	Z	A	B	C	D	E	F
1	GND	GA4	GA3	GA2	GA1	GA0	GND
2	GND	5Vaux	GND	SYSEN#	WAKE#	ALERT#	GND
3	GND	12V	12V	GND	GND	GND	GND
4	GND	GND	GND	3.3V	3.3V	3.3V	GND
5	GND	PXI_TRIG3	PXI_TRIG4	PXI_TRIG5	GND	PXI_TRIG6	GND
6	GND	PXI_TRIG2	GND	ATNLED	PXI_STAR	PXI_CLK10	GND
7	GND	PXI_TRIG1	PXI_TRIG0	ATNSW#	GND	PXI_TRIG7	GND
8	GND	RSV	GND	RSV	PXI_LBL6	PXI_LBR6	GND



---

# TI StellarisWare Clickwrap Software License Agreement (SLA)

## Software License Agreement

---

Redistribution and use in source and binary forms, with or without modification, are permitted provided that the following conditions are met:

Redistributions of source code must retain the original copyright notice, this list of conditions and the following disclaimer.

Redistributions in binary form must reproduce the original copyright notice, this list of conditions and the following disclaimer in the documentation and/or other materials provided with the distribution.

Neither the name of Texas Instruments Incorporated nor the names of its contributors may be used to endorse or promote products derived from this software without specific prior written permission.

THIS SOFTWARE IS PROVIDED BY THE COPYRIGHT HOLDERS AND CONTRIBUTORS “AS IS” AND ANY EXPRESS OR IMPLIED WARRANTIES, INCLUDING, BUT NOT LIMITED TO, THE IMPLIED WARRANTIES OF MERCHANTABILITY AND FITNESS FOR A PARTICULAR PURPOSE ARE DISCLAIMED. IN NO EVENT SHALL THE COPYRIGHT OWNER OR CONTRIBUTORS BE LIABLE FOR ANY DIRECT, INDIRECT, INCIDENTAL, SPECIAL, EXEMPLARY, OR CONSEQUENTIAL DAMAGES (INCLUDING, BUT NOT LIMITED TO, PROCUREMENT OF SUBSTITUTE GOODS OR SERVICES; LOSS OF USE, DATA, OR PROFITS; OR BUSINESS INTERRUPTION) HOWEVER CAUSED AND ON ANY THEORY OF LIABILITY, WHETHER IN CONTRACT, STRICT LIABILITY, OR TORT (INCLUDING NEGLIGENCE OR OTHERWISE) ARISING IN ANY WAY OUT OF THE USE OF THIS SOFTWARE, EVEN IF ADVISED OF THE POSSIBILITY OF SUCH DAMAGE.

**Important-**This is a legally binding agreement. Read it carefully. After you read the following terms, you will be asked whether you are authorized to commit your company to abide by the following terms. THIS AGREEMENT IS DISPLAYED FOR YOU TO READ PRIOR TO DOWNLOADING OR USING THE “LICENSED MATERIALS”. DO NOT DOWNLOAD OR INSTALL the software programs unless you agree on behalf of yourself and your company to be bound by the terms of this License Agreement.

**DO NOT CLICK “I AGREE” UNLESS:**

1. YOU ARE AUTHORIZED TO AGREE TO THE TERMS OF THIS LICENSE ON BEHALF OF YOURSELF AND YOUR COMPANY; AND
2. YOU INTEND TO ENTER THIS LEGALLY BINDING AGREEMENT ON BEHALF OF YOURSELF AND YOUR COMPANY.

**Important - Read carefully:** This software license agreement (“Agreement”) is a legal agreement between you (either an individual or entity) and Texas Instruments Incorporated (“TI”). The “Licensed Materials” subject to this Agreement include the software programs TI has granted you access to download and any “on-line” or electronic documentation associated with these programs, or any portion thereof, and may also include hardware, reference designs and associated documentation. The Licensed Materials are specifically designed and licensed for use solely and exclusively with microprocessor/microcontroller devices manufactured by or for TI (“TI Devices”). By installing, copying or otherwise using the Licensed Materials you agree to abide by the provisions set forth herein. This Agreement is displayed for you to read prior to using the Licensed Materials. If you choose not to accept or agree with these provisions, do not download or install the Licensed Materials.

1. Delivery. TI may deliver the Licensed Materials, or portions thereof, to you electronically.
2. License Grant and Use Restrictions.
  - a. Limited Source Code License. Subject to the terms of this Agreement, and commencing as of the Effective Date and continuing for the term of this Agreement, TI hereby grants to you a limited, free, non-transferable, non-exclusive, non-assignable, non-sub-licensable license to make copies, prepare derivative works, display internally and use internally the Licensed Materials provided to you in source code for the sole purposes of designing and developing object and executable versions of such Licensed Materials or any derivative thereof, that execute solely and exclusively on TI Devices used in Customer Product(s), and maintaining and supporting such Licensed Materials, or any derivative thereof, and Customer Product(s). “Customer Product” means a final product distributed by or for you that consists of both hardware, including one or more TI Devices, and software components, including only executable versions of the Licensed Materials that execute solely and exclusively on or with such TI Devices and not on devices manufactured by or for an entity other than TI.
  - b. Production and Distribution License. Subject to the terms of this Agreement, and commencing as of the Effective Date and continuing for the term of this Agreement, TI hereby grants to you a free, non-exclusive, non-transferable, non-assignable, worldwide license to:
    - (i). Use object code versions of the Licensed Materials, or any derivative thereof, to make copies, display internally, evaluate, test, distribute internally and use internally for the sole purposes of designing and developing Customer Product(s), and maintaining and supporting the Licensed Materials and Customer Product(s);
    - (ii). Make copies, use, sell, offer to sell, and otherwise distribute object code and executable versions of the Licensed Materials, or any derivative thereof, for use in or

- with Customer Product(s), provided that such Licensed Materials are embedded in or only used with Customer Product(s), and provided further that such Licensed Materials execute solely and exclusively on a TI Device and not on any device manufactured by or for an entity other than TI.
- c. **Demonstration License.** Subject to the terms of this Agreement, and commencing as of the Effective Date and continuing for the term of this Agreement, TI grants to you a free, non-transferable, non-exclusive, non-assignable, non-sub-licensable worldwide license to demonstrate to third parties the Licensed Materials as they are used in Customer Products executing solely and exclusively on TI Devices, provided that such Licensed Materials are demonstrated in object or executable versions only.
  - d. **Reference Design Use License.** Subject to the terms of this Agreement, and commencing as of the Effective Date and continuing for the term of this Agreement, TI hereby grants to you a free, non-transferable, non-exclusive, non-assignable, non-sub-licensable worldwide license to:
    - (i) use the Licensed Materials to design, develop, manufacture or have manufactured, sell, offer to sell, or otherwise distribute Customer Product(s) or product designs, including portions or derivatives of the Licensed Materials as they are incorporated in or used with Customer Product(s), provided such Customer Products or product designs utilize a TI Device.
  - e. **Contractors and Suppliers.** The licenses granted to you hereunder shall include your on-site and off-site suppliers and independent contractors, while such suppliers and independent contractors are performing work for or providing services to you, provided that such suppliers and independent contractors have executed work-for-hire agreements with you containing terms and conditions not inconsistent with the terms and conditions set forth in this Agreement and provided further that such contractors may provide work product to only you under such work-for-hire agreements.
  - f. **No Other License.** Notwithstanding anything to the contrary, nothing in this Agreement shall be construed as a license to any intellectual property rights of TI other than those rights embodied in the Licensed Materials provided to you by TI. EXCEPT AS PROVIDED HEREIN, NO OTHER LICENSE, EXPRESS OR IMPLIED, BY ESTOPPEL OR OTHERWISE, TO ANY OTHER TI INTELLECTUAL PROPERTY RIGHTS IS GRANTED HEREIN.
  - g. **Restrictions.** You shall maintain the source code versions of the Licensed Materials under password control protection and shall not disclose such source code versions of the Licensed Materials, or any derivative thereof, to any person other than your employees and contractors whose job performance requires access. You shall not use the Licensed Materials with a processing device manufactured by or for an entity other than TI, and you agree that any such unauthorized use of the Licensed Materials is a material breach of this Agreement. Except as expressly provided in this Agreement, you shall not copy, publish, disclose, display, provide, transfer or make available the Licensed Materials to any third party and you shall not sublicense, transfer, or assign the Licensed Materials or your rights under this Agreement to any third party. You shall not mortgage, pledge or encumber the Licensed Materials in any way. You shall not (i) incorporate, combine, or distribute the Licensed Materials, or any derivative

thereof, with any Public Software, or (ii) use Public Software in the development of any derivatives of the Licensed Materials, each in such a way that would cause the Licensed Materials, or any derivative thereof, to be subject to all or part of the license obligations or other intellectual property related terms with respect to such Public Software, including but not limited to, the obligations that the Licensed Materials, or any derivative thereof, incorporated into, combined, or distributed with such Public Software (x) be disclosed or distributed in source code form, be licensed for the purpose of making derivatives of such software, or be redistributed free of charge, contrary to the terms and conditions of this Agreement, (y) be used with devices other than TI Devices, or (z) be otherwise used or distributed in a manner contrary to the terms and conditions of this Agreement. As used in this Section 2(g), “Public Software” means any software that contains, or is derived in whole or in part from, any software distributed as open source software, including but not limited to software licensed under the following or similar models: (A) GNU’s General Public License (GPL) or Lesser/Library GPL (LGPL), (B) the Artistic License (e.g., PERL), (C) the Mozilla Public License, (D) the Netscape Public License, (E) the Sun Community Source License (SCSL), (F) the Sun Industry Standards Source License (SISL), (G) the Apache Server license, (H) QT Free Edition License, (I) IBM Public License, and (J) BitKeeper.

- h. Termination. This Agreement is effective until terminated. You may terminate this Agreement at any time by written notice to TI. Without prejudice to any other rights, if you fail to comply with the terms of this Agreement, TI may terminate your right to use the Licensed Materials upon written notice to you. Upon termination of this Agreement, you will destroy any and all copies of the Licensed Materials in your possession, custody or control and provide to TI a written statement signed by your authorized representative certifying such destruction. The following sections will survive any expiration or termination of this Agreement: 2(h) (Termination), 3 (Licensed Materials Ownership), 6 (Warranties and Limitations), 7 (Indemnification Disclaimer), 10 (Export Control), 11 (Governing Law and Severability), 12 (PRC Provisions), and 13 (Entire Agreement). The obligations set forth in Section 5 (Confidential Information) will survive any expiration or termination of this Agreement for three (3) years after such expiration or termination.
3. Licensed Materials Ownership. The Licensed Materials are licensed, not sold to you, and can only be used in accordance with the terms of this Agreement. Subject to the licenses granted to you pursuant to this Agreement, TI and TI’s licensors own and shall continue to own all right, title, and interest in and to the Licensed Materials, including all copies thereof. The parties agree that all fixes, modifications and improvements to the Licensed Materials conceived of or made by TI that are based, either in whole or in part, on your feedback, suggestions or recommendations are the exclusive property of TI and all right, title and interest in and to such fixes, modifications or improvements to the Licensed Materials will vest solely in TI. Moreover, you acknowledge and agree that when your independently developed software or hardware components are combined, in whole or in part, with the Licensed Materials, your right to use the Licensed Materials embodied in such resulting combined work shall remain subject to the terms and conditions of this Agreement.

4. Intellectual Property Rights.
  - a. The Licensed Materials contain copyrighted material, trade secrets and other proprietary information of TI and TI's licensors and are protected by copyright laws, international copyright treaties, and trade secret laws, as well as other intellectual property laws. To protect TI's and TI's licensors' rights in the Licensed Materials, you agree, except as specifically permitted by statute by a provision that cannot be waived by contract, not to "unlock", decompile, reverse engineer, disassemble or otherwise translate any portions of the Licensed Materials to a human-perceivable form nor to permit any person or entity to do so. You shall not remove, alter, cover, or obscure any confidentiality, trade secret, proprietary, or copyright notices, trade-marks, proprietary, patent, or other identifying marks or designs from any component of the Licensed Materials and you shall reproduce and include in all copies of the Licensed Materials the copyright notice(s) and proprietary legend(s) of TI and TI's licensors as they appear in the Licensed Materials. TI reserves all rights not specifically granted under this Agreement.
  - b. Third parties may claim to own patents, copyrights, or other intellectual property rights that cover the implementation of certain Licensed Materials. Certain Licensed Materials may also be based on industry recognized standards, including but not limited to specifically the ISO MPEG and ITU standards, and software programs published by industry recognized standards bodies and certain third parties claim to own patents, copyrights, and other intellectual property rights that cover implementation of those standards. You acknowledge and agree that this Agreement does not convey a license to any such third party patents, copyrights, and other intellectual property rights and that you are solely responsible for any patent, copyright, or other intellectual property right claims that relate to your use and distribution of the Licensed Materials, and your use and distribution of your products that include or incorporate the Licensed Materials.
5. Confidential Information. You acknowledge and agree that the Licensed Materials contain trade secrets and other confidential information of TI and TI's licensors. You agree to use the Licensed Materials solely within the scope of the licenses set forth herein, to maintain the Licensed Materials in strict confidence, to use at least the same procedures and degree of care that you use to prevent disclosure of your own confidential information of like importance but in no instance less than reasonable care, and to prevent disclosure of the Licensed Materials to any third party, except as may be necessary and required in connection with your rights and obligations hereunder. You agree to obtain executed confidentiality agreements with your employees and contractors having access to the Licensed Materials and to diligently take steps to enforce such agreements in this respect. TI agrees that the employment agreements used in the normal course of your business shall satisfy the requirements of this section. TI may disclose your contact information to TI's applicable licensors.
6. Warranties and Limitations. **YOU ACKNOWLEDGE AND AGREE THAT THE LICENSED MATERIALS MAY NOT BE INTENDED FOR PRODUCTION APPLICATIONS AND MAY CONTAIN IRREGULARITIES AND DEFECTS NOT FOUND IN PRODUCTION SOFTWARE. FURTHERMORE, YOU ACKNOWLEDGE**

AND AGREE THAT THE LICENSED MATERIALS HAVE NOT BEEN TESTED OR CERTIFIED BY ANY GOVERNMENT AGENCY OR INDUSTRY REGULATORY ORGANIZATION OR ANY OTHER THIRD PARTY ORGANIZATION. YOU AGREE THAT PRIOR TO USING, INCORPORATING OR DISTRIBUTING THE LICENSED MATERIALS IN OR WITH ANY COMMERCIAL PRODUCT THAT YOU WILL THOROUGHLY TEST THE PRODUCT AND THE FUNCTIONALITY OF THE LICENSED MATERIALS IN OR WITH THAT PRODUCT AND BE SOLELY RESPONSIBLE FOR ANY PROBLEMS OR FAILURES.

THE LICENSED MATERIALS AND ANY RELATED DOCUMENTATION ARE PROVIDED "AS IS" AND WITH ALL FAULTS. TI MAKES NO WARRANTY OR REPRESENTATION, WHETHER EXPRESS, IMPLIED OR STATUTORY, REGARDING THE LICENSED MATERIALS, INCLUDING BUT NOT LIMITED TO, ANY IMPLIED WARRANTIES OF MERCHANTABILITY OR FITNESS FOR A PARTICULAR PURPOSE, LACK OF VIRUSES, ACCURACY OR COMPLETENESS OF RESPONSES, RESULTS AND LACK OF NEGLIGENCE. TI DISCLAIMS ANY WARRANTY OF TITLE, QUIET ENJOYMENT, QUIET POSSESSION, AND NON-INFRINGEMENT OF ANY THIRD PARTY PATENTS, COPYRIGHTS, TRADE SECRETS OR OTHER INTELLECTUAL PROPERTY RIGHTS. YOU AGREE TO USE YOUR INDEPENDENT JUDGMENT IN DEVELOPING YOUR PRODUCTS. NOTHING CONTAINED IN THIS AGREEMENT WILL BE CONSTRUED AS A WARRANTY OR REPRESENTATION BY TI TO MAINTAIN PRODUCTION OF ANY TI SEMICONDUCTOR DEVICE OR OTHER HARDWARE OR SOFTWARE WITH WHICH THE LICENSED MATERIALS MAY BE USED.

IN NO EVENT SHALL TI, OR ANY APPLICABLE LICENSOR, BE LIABLE FOR ANY SPECIAL, INDIRECT, INCIDENTAL, PUNITIVE OR CONSEQUENTIAL DAMAGES, HOWEVER CAUSED, ON ANY THEORY OF LIABILITY, IN CONNECTION WITH OR ARISING OUT OF THIS AGREEMENT OR THE USE OF THE LICENSED MATERIALS, REGARDLESS OF WHETHER TI HAS BEEN ADVISED OF THE POSSIBILITY OF SUCH DAMAGES. EXCLUDED DAMAGES INCLUDE, BUT ARE NOT LIMITED TO, COST OF REMOVAL OR REINSTALLATION, OUTSIDE COMPUTER TIME, LABOR COSTS, LOSS OF DATA, LOSS OF GOODWILL, LOSS OF PROFITS, LOSS OF SAVINGS, OR LOSS OF USE OR INTERRUPTION OF BUSINESS. IN NO EVENT WILL TI'S AGGREGATE LIABILITY UNDER THIS AGREEMENT OR ARISING OUT OF YOUR USE OF THE LICENSED MATERIALS EXCEED FIVE HUNDRED U.S. DOLLARS (US\$500). THE EXISTENCE OF MORE THAN ONE CLAIM WILL NOT ENLARGE OR EXTEND THESE LIMITS.

Because some jurisdictions do not allow the exclusion or limitation of incidental or consequential damages or limitation on how long an implied warranty lasts, the above limitations or exclusions may not apply to you.

7. **Indemnification Disclaimer.** YOU ACKNOWLEDGE AND AGREE THAT TI SHALL NOT BE LIABLE FOR AND SHALL NOT DEFEND OR INDEMNIFY YOU AGAINST ANY THIRD PARTY INFRINGEMENT CLAIM THAT RELATES TO OR IS BASED ON YOUR MANUFACTURE, USE, OR DISTRIBUTION OF THE LICENSED

MATERIALS OR YOUR MANUFACTURE, USE, OFFER FOR SALE, SALE, IMPORTATION OR DISTRIBUTION OF YOUR PRODUCTS THAT INCLUDE OR INCORPORATE THE LICENSED MATERIALS.

You will defend and indemnify TI in the event of claim, liability or costs (including reasonable attorney's fees related to Your use or any sub-licensee's use of the Licensed Materials) relating in any way to Your violation of the terms of the License Grants set forth in Section 2, or any other violation of other terms and conditions of this Agreement.

8. No Technical Support. TI and TI's licensors are under no obligation to install, maintain or support the Licensed Materials.
9. Notices. All notices to TI hereunder shall be delivered to Texas Instruments Incorporated, AEC Software Operations, 12203 Southwest Freeway, Mail Station 701, Stafford, Texas 77477, Attention: Administrator, AEC Software Operations, with a copy to Texas Instruments Incorporated, 12203 Southwest Freeway, Mail Station 725, Stafford, Texas 77477, Attention: Legal Department. All notices shall be deemed served when received by TI.
10. Export Control. You hereby acknowledge that the Licensed Materials are subject to export control under the U.S. Commerce Department's Export Administration Regulations ("EAR"). You further hereby acknowledge and agree that unless prior authorization is obtained from the U.S. Commerce Department, neither you nor your customers will export, re-export, or release, directly or indirectly, any technology, software, or software source code (as defined in Part 772 of the EAR), received from TI, or export, directly or indirectly, any direct product of such technology, software, or software source code (as defined in Part 734 of the EAR), to any destination or country to which the export, re-export, or release of the technology, software, or software source code, or direct product is prohibited by the EAR. You agree that none of the Licensed Materials may be downloaded or otherwise exported or reexported (i) into (or to a national or resident of) Cuba, Iran, North Korea, Sudan and Syria or any other country the U.S. has embargoed goods; or (ii) to anyone on the U.S. Treasury Department's List of Specially Designated Nationals or the U.S. Commerce Department's Denied Persons List or Entity List. You represent and warrant that you are not located in, under the control of, or a national or resident of any such country or on any such list and you will not use or transfer the Licensed Materials for use in any sensitive nuclear, chemical or biological weapons, or missile technology end-uses unless authorized by the U.S. Government by regulation or specific license or for a military end-use in, or by any military entity of Albania, Armenia, Azerbaijan, Belarus, Cambodia, China, Georgia, Iran, Iraq, Kazakhstan, Kyrgyzstan, Laos, Libya, Macau, Moldova, Mongolia, Russia, Tajikistan, Turkmenistan, Ukraine, Uzbekistan, and Vietnam. Any software export classification made by TI shall be for TI's internal use only and shall not be construed as a representation or warranty regarding the proper export classification for such software or whether an export license or other documentation is required for the exportation of such software.
11. Governing Law and Severability. This Agreement will be governed by and interpreted in accordance with the laws of the State of Texas, without reference to conflict of laws principles. If for any reason a court of competent jurisdiction finds any provision of the Agreement to be unenforceable, that provision will be enforced to the maximum extent possible to effectuate the intent of the parties, and the remainder of the Agreement shall



continue in full force and effect. This Agreement shall not be governed by the United Nations Convention on Contracts for the International Sale of Goods, or by the Uniform Computer Information Transactions Act (UCITA), as it may be enacted in the State of Texas. The parties agree that non-exclusive jurisdiction for any dispute arising out of or relating to this Agreement lies within the courts located in the State of Texas. Notwithstanding the foregoing, any judgment may be enforced in any United States or foreign court, and either party may seek injunctive relief in any United States or foreign court.

12. PRC Provisions. If you are located in the People's Republic of China ("PRC") or if the Licensed Materials will be sent to the PRC, the following provisions shall apply and shall supersede any other provisions in this Agreement concerning the same subject matter as the following provisions:
  - a. Registration Requirements. You shall be solely responsible for performing all acts and obtaining all approvals that may be required in connection with this Agreement by the government of the PRC, including but not limited to registering pursuant to, and otherwise complying with, the PRC Measures on the Administration of Software Products, Management Regulations on Technology Import-Export, and Technology Import and Export Contract Registration Management Rules. Upon receipt of such approvals from the government authorities, you shall forward evidence of all such approvals to TI for its records. In the event that you fail to obtain any such approval or registration, you shall be solely responsible for any and all losses, damages or costs resulting therefrom, and shall indemnify TI for all such losses, damages or costs.
  - b. Governing Language. This Agreement is written and executed in the English language. If a translation of this Agreement is required for any purpose, including but not limited to registration of the Agreement pursuant to any governmental laws, regulations or rules, you shall be solely responsible for creating such translation. Any translation of this Agreement into a language other than English is intended solely in order to comply with such laws or for reference purposes, and the English language version shall be authoritative and controlling.
  - c. Export Control.
    - (i). Diversions of Technology. You hereby agree that unless prior authorization is obtained from the U.S. Department of Commerce, neither you nor your subsidiaries or affiliates shall knowingly export, re-export, or release, directly or indirectly, any technology, software, or software source code (as defined in Part 772 of the Export Administration Regulations of the U.S. Department of Commerce ("EAR")), received from TI or any of its affiliated companies, or export, directly or indirectly, any direct product of such technology, software, or software source code (as defined in Part 734 of the EAR), to any destination or country to which the export, re-export, or release of the technology, software, software source code, or direct product is prohibited by the EAR.
    - (ii). Assurance of Compliance. You understand and acknowledge that products, technology (regardless of the form in which it is provided), software or software source code, received from TI or any of its affiliates under this Agreement may be under export control of the United States or other countries. You shall comply with the

United States and other applicable non-U.S. laws and regulations governing the export, re-export and release of any products, technology, software, or software source code received under this Agreement from TI or its affiliates. You shall not undertake any action that is prohibited by the EAR. Without limiting the generality of the foregoing, you specifically agree that you shall not transfer or release products, technology, software, or software source code of TI or its affiliates to, or for use by, military end users or for use in military, missile, nuclear, biological, or chemical weapons end uses.

(iii). Licenses. Each party shall secure at its own expense, such licenses and export and import documents as are necessary for each respective party to fulfill its obligations under this Agreement. If such licenses or government approvals cannot be obtained, TI may terminate this Agreement, or shall otherwise be excused from the performance of any obligations it may have under this Agreement for which the licenses or government approvals are required.

13. Entire Agreement. This is the entire Agreement between you and TI, and absent a signed and effective software license agreement related to the subject matter of this Agreement, this Agreement supersedes any prior agreement between the parties related to the subject matter of this Agreement. Notwithstanding the foregoing, any signed and effective software license agreement relating to the subject matter hereof will supersede the terms of this Agreement. No amendment or modification of this Agreement will be effective unless in writing and signed by a duly authorized representative of TI. You hereby warrant and represent that you have obtained all authorizations and other applicable consents required empowering you to enter into this Agreement.

---

# NI Services

National Instruments provides global services and support as part of our commitment to your success. Take advantage of product services in addition to training and certification programs that meet your needs during each phase of the application life cycle; from planning and development through deployment and ongoing maintenance.

To get started, register your product at [ni.com/myproducts](https://ni.com/myproducts).

As a registered NI product user, you are entitled to the following benefits:

- Access to applicable product services.
- Easier product management with an online account.
- Receive critical part notifications, software updates, and service expirations.

Log in to your National Instruments [ni.com](https://ni.com) User Profile to get personalized access to your services.

---

## Services and Resources

- **Maintenance and Hardware Services**—NI helps you identify your systems' accuracy and reliability requirements and provides warranty, sparing, and calibration services to help you maintain accuracy and minimize downtime over the life of your system. Visit [ni.com/services](https://ni.com/services) for more information.
  - **Warranty and Repair**—All NI hardware features a one-year standard warranty that is extendable up to five years. NI offers repair services performed in a timely manner by highly trained factory technicians using only original parts at a National Instruments service center.
  - **Calibration**—Through regular calibration, you can quantify and improve the measurement performance of an instrument. NI provides state-of-the-art calibration services. If your product supports calibration, you can obtain the calibration certificate for your product at [ni.com/calibration](https://ni.com/calibration).
- **System Integration**—If you have time constraints, limited in-house technical resources, or other project challenges, National Instruments Alliance Partner members can help. To learn more, call your local NI office or visit [ni.com/alliance](https://ni.com/alliance).

- **Training and Certification**—The NI training and certification program is the most effective way to increase application development proficiency and productivity. Visit [ni.com/training](https://ni.com/training) for more information.
  - The Skills Guide assists you in identifying the proficiency requirements of your current application and gives you options for obtaining those skills consistent with your time and budget constraints and personal learning preferences. Visit [ni.com/skills-guide](https://ni.com/skills-guide) to see these custom paths.
  - NI offers courses in several languages and formats including instructor-led classes at facilities worldwide, courses on-site at your facility, and online courses to serve your individual needs.
- **Technical Support**—Support at [ni.com/support](https://ni.com/support) includes the following resources:
  - **Self-Help Technical Resources**—Visit [ni.com/support](https://ni.com/support) for software drivers and updates, a searchable KnowledgeBase, product manuals, step-by-step troubleshooting wizards, thousands of example programs, tutorials, application notes, instrument drivers, and so on. Registered users also receive access to the NI Discussion Forums at [ni.com/forums](https://ni.com/forums). NI Applications Engineers make sure every question submitted online receives an answer.
  - **Software Support Service Membership**—The Standard Service Program (SSP) is a renewable one-year subscription included with almost every NI software product, including NI Developer Suite. This program entitles members to direct access to NI Applications Engineers through phone and email for one-to-one technical support, as well as exclusive access to online training modules at [ni.com/self-paced-training](https://ni.com/self-paced-training). NI also offers flexible extended contract options that guarantee your SSP benefits are available without interruption for as long as you need them. Visit [ni.com/ssp](https://ni.com/ssp) for more information.
- **Declaration of Conformity (DoC)**—A DoC is our claim of compliance with the Council of the European Communities using the manufacturer’s declaration of conformity. This system affords the user protection for electromagnetic compatibility (EMC) and product safety. You can obtain the DoC for your product by visiting [ni.com/certification](https://ni.com/certification).

For information about other technical support options in your area, visit [ni.com/services](https://ni.com/services), or contact your local office at [ni.com/contact](https://ni.com/contact).

You also can visit the Worldwide Offices section of [ni.com/niglobal](https://ni.com/niglobal) to access the branch office websites, which provide up-to-date contact information, support phone numbers, email addresses, and current events.

# Glossary

---

Symbol	Prefix	Value
p	pico	$10^{-12}$
n	nano	$10^{-9}$
$\mu$	micro	$10^{-6}$
m	milli	$10^{-3}$
k	kilo	$10^3$
M	mega	$10^6$
G	giga	$10^9$
T	tera	$10^{12}$

## Symbols

°	Degrees.
≥	Equal or greater than.
≤	Equal or less than.
%	Percent.

## A

A	Amperes.
AC	Alternating current.
ANSI	American National Standards Institute.
Auto	Automatic fan speed control.
AWG	American Wire Gauge.

## B

backplane	An assembly, typically a printed circuit board, with connectors and signal paths that bus the connector pins.
BNC	Bayonet Neill Concelman connector—A commonly used coaxial connector.

## C

C	Celsius.
cfm	Cubic feet per minute.
CFR	Code of Federal Regulations.
cm	Centimeters.
CompactPCI	An adaptation of the Peripheral Component Interconnect (PCI) Specification 2.1 or later for industrial and/or embedded applications requiring a more robust mechanical form factor than desktop PCI. It uses industry standard mechanical components and high-performance connector technologies to provide an optimized system intended for rugged applications. It is electrically compatible with the PCI Specification, which enables low-cost PCI components to be utilized in a mechanical form factor suited for rugged environments.
CSA	Canadian Standards Association.

## D

daisy-chain	A method of propagating signals along a bus, in which the devices are prioritized on the basis of their position on the bus.
DB-9	A 9-pin D-SUB connector.
DC	Direct current.
DoC	Declaration of Conformity.
D-SUB	Subminiature D connector.

**E**

efficiency	Ratio of output power to input power, expressed as a percentage.
EIA	Electronic Industries Association.
EMC	Electromagnetic Compatibility.
EMI	Electromagnetic Interference.

**F**

FCC	Federal Communications Commission.
filler panel	A blank module front panel used to fill empty slots in the chassis.

**G**

g	(1) grams; (2) a measure of acceleration equal to 9.8 m/s <sup>2</sup> .
GPIB	General Purpose Interface Bus (IEEE 488).
g <sub>RMS</sub>	A measure of random vibration. The root mean square of acceleration levels in a random vibration test profile.

**H**

hr	Hours.
Hz	Hertz—Cycles per second.

**I**

IEC	International Electrotechnical Commission—An organization that sets international electrical and electronics standards.
IEEE	Institute of Electrical and Electronics Engineers.
I <sub>MP</sub>	Mainframe peak current.

## Glossary

in. Inches.

inhibit To turn off.

## J

jitter A measure of the small, rapid variations in clock transition times from their nominal regular intervals. Units: seconds RMS.

## K

kg Kilograms.

km Kilometers.

## L

lb Pounds.

LED Light emitting diode.

line regulation The maximum steady-state percentage that a DC voltage output will change as a result of a specified change in input AC voltage (step change from 90 to 132 VAC or 180 to 264 VAC).

load regulation The maximum steady-state percentage that a DC voltage output will change as a result of a step change from no-load to full-load output current.

## M

m Meters.

MHz Megahertz—One million Hertz; one Hertz equals one cycle per second.

mi Miles.

ms Milliseconds.

MTBF Mean time between failure.



MTTR Mean time to repair.

## N

NEMA National Electrical Manufacturers Association.

NI National Instruments.

## P

power supply shuttle A removable module that contains the chassis power supply.

PXI PCI eXtensions for Instrumentation.

PXI\_CLK10 10 MHz PXI system reference clock.

## R

RH Relative humidity.

RMS Root mean square.

## S

s Seconds.

skew Deviation in signal transmission times.

slot blocker An assembly installed into an empty slot to improve the airflow in adjacent slots.

standby The backplane is unpowered (off), but the chassis is still connected to AC power mains.

System controller A module configured for installation in Slot 1 of a PXI chassis. This device is unique in the PXI system in that it performs the system controller functions, including clock sourcing and arbitration for data transfers across the backplane. Installing such a device into any other slot can damage the device, the PXI backplane, or both.

## Glossary

system reference clock A 10 MHz clock, also called PXI\_CLK10, that is distributed to all peripheral slots in the chassis, as well as a BNC connector on the rear of chassis labeled *10 MHz REF OUT*. The system reference clock can be used for synchronization of multiple modules in a measurement or control system. The 10 MHz REF IN and OUT BNC connectors on the rear of the chassis can be used to synchronize multiple chassis to one reference clock. The PXI backplane specification defines implementation guidelines for PXI\_CLK10.

System Timing slot This slot is located at slot 4 and has dedicated trigger lines to other slots.

## T

TTL Transistor-transistor logic.

## U

UL Underwriter's Laboratories.

## V

V Volts.

VAC Volts alternating current.

$V_{pp}$  Peak-to-peak voltage.

## W

W Watts.

# Index

---

## A

AC power cables (table), 1-2

## B

backplane

- hybrid peripheral slots, 1-7
- interoperability with CompactPCI, 1-6
- overview, 1-6
- PXI local bus, routing, 1-9
- PXIe\_SYNC\_CTRL, 1-11, 1-12
- specifications, A-6
- system controller slot, 1-6
- system reference clock, 1-10
  - default behavior (figure), 1-10
- system timing slot, 1-8
- trigger bus, 1-9

## C

- cables, power (table), 1-2
- CE compliance specifications, A-5
- chassis ambient temperature definitions, 2-4
- chassis configuration web page (figure), 2-10
- chassis cooling considerations
  - ambient temperature definitions, 2-4
  - clearances, 2-2
    - figure, 2-3
    - vents (figure), 2-4
- chassis description, 1-4
- chassis fan LED behavior (table), 2-12
- chassis initialization file, 2-17
- chassis LED indicators, 2-11
- chassis ventilation (figure), 2-4
- cleaning chassis, 3-1
- clearances for chassis cooling, 2-2
  - figure, 2-3
- CLK10 rear connectors, 2-14
- CompactPCI, interoperability with
  - PXIe-1086 backplane, 1-6
- configuration in MAX (figure), 2-15
- configuration. *See* installation, configuration, and operation

cooling

- air cooling of PXIe-1086 chassis, 2-2
- filler panel installation, 2-5
- setting fan speed, 2-5
- slot blocker installation, 2-5

## D

- Declaration of Conformity (NI resources), D-2
- default configuration settings, 2-11
- diagnostic tools (NI resources), D-2
- dimensions (figure), A-10, A-11
- documentation
  - NI resources, D-1
  - related documentation, *xi*
- drivers (NI resources), D-2

## E

- electromagnetic compatibility, A-5
- EMC filler panel kit, 1-5
- environmental management
  - specifications, A-6
- Ethernet LED behavior (figure), 2-11
- examples (NI resources), D-2
- external clock source specifications, A-8

## F

- fan access door clearance (figure), 2-5
- fan assembly (figure), 3-7
- fan, setting speed, 2-5
- filler panel installation, 2-5

## G

- ground, connecting, 2-6

## H

- help, technical support, D-1
- hybrid peripheral slots, description, 1-7
- hybrid slot pinouts
  - P1 connector (table), B-9
  - XP3 connector (table), B-10
  - XP4 connector (table), B-10

**I**

IEC 320 inlet, 1-5, 2-6, 3-3, 3-4, 3-7

inhibit mode switch, 2-14

installation, configuration, and operation
 

- chassis initialization file, 2-17
- configuration in MAX (figure), 2-15
- connecting safety ground, 2-6
- filler panel installation, 2-5
- installing a PXI Express system controller, 2-7
  - figure, 2-7
- module installation, CompactPCI or PXI modules (figure), 2-9
- peripheral module installation, 2-8
  - figure, 2-9
- PXI Express configuration in MAX, 2-14
- PXI Express system controller installed in a PXIe-1086 chassis (figure), 2-8
- PXI trigger bus routing, 2-16
- PXI-1 configuration in MAX, 2-15
- rack mounting, 2-6
- setting fan speed, 2-5
- site considerations, 2-2
- slot blocker installation, 2-5
- testing power up, 2-6
- trigger configuration in MAX, 2-16
- unpacking the PXIe-1086, 1-1

installing a PXI Express system controller (figure), 2-7

instrument drivers (NI resources), D-2

interoperability with CompactPCI, 1-6

**K**

key features, 1-2

kit contents, 1-1

KnowledgeBase, D-2

**M**

main chassis LED behavior (table), 2-11

maintenance of PXIe-1086 chassis, 3-1
 

- cleaning, 3-1
  - exterior cleaning, 3-2
  - interior cleaning, 3-1

fan assembly, replacing, 3-6

power supply, replacing, 3-2

preparation, 3-1

service interval, 3-1

static discharge damage (caution), 3-1

**N**

National Instruments support and services, D-1

NI support and services, D-1

**O**

optional equipment, 1-5

**P**

peripheral module installation, 2-8
 

- figure, 2-9

peripheral slot pinouts
 

- P1 connector (table), B-7
- P2 connector (table), B-8

pinouts, B-1

power cables (table), 1-2

power drawer (figure), 3-4

power supply
 

- connecting to, 2-6
- LED behavior (table), 2-13
- removing (figure), 3-3
- replacing, 3-2

power supply filler panel kit, 1-5

power up, testing, 2-6

programming examples (NI resources), D-2

PXI differential star trigger specifications (PXIe-DSTARA, PXIe-DSTARB, PXIe-DSTARC), A-8

PXI Express configuration in MAX, 2-14

PXI Express Star, routing, 1-9

PXI Express system controller, 2-7
 

- figure, 2-7
- installing in a PXIe-1086 chassis (figure), 2-8

PXI local bus, routing, 1-9

PXI star trigger specifications, A-8

PXI star, routing, 1-9

PXI-1 configuration in MAX, 2-15

- PXIe\_SYNC\_CTRL, 1-11
  - specifications, A-8
  - using as restart (figure), 1-12
- PXIe-1086
  - fan assembly, replacing, 3-6
  - fan speed, setting, 2-5
  - front view (figure), 1-4
  - installation. *See* installation, configuration, and operation
  - key features, 1-2
  - maintenance. *See* maintenance of NI PXIe-1086 chassis
  - optional equipment, 1-5
  - power drawer (figure), 3-4
  - power supply, replacing, 3-2
  - rack mounting, 2-6
  - rear view (figure), 1-5
  - removing power supply (figure), 3-3
  - safety ground, connecting, 2-6
  - unpacking, 1-1
  - with fan assembly removed (figure), 3-7
- PXIe-1086 backplane
  - hybrid peripheral slots, 1-7
  - interoperability with CompactPCI, 1-6
  - overview, 1-6
  - PXI local bus, routing, 1-9
  - PXIe\_SYNC\_CTRL, 1-11
    - using as restart (figure), 1-12
  - specifications, A-6
  - system controller slot, 1-6
  - system reference clock, 1-10
    - default behavior (figure), 1-10
  - system timing slot, 1-8
  - trigger bus, 1-9

## R

- rack mount kit dimensions (figure), A-12
- rack mounting, 2-6
  - kit, 1-5
- related documentation, *xi*
- remote inhibit and fault connector pinout (table), 2-13
- remote inhibit and fault monitoring, 2-13
- remote system monitoring, 2-10

## S

- safety and caution notices, 2-1
- safety ground, connecting, 2-6
- safety specifications, A-5
- service interval, 3-1
- setting fan speed, 2-5
- slot blocker
  - installation, 2-5
  - kit, 1-5
- software (NI resources), D-1
- specifications, A-1
  - acoustic emissions
    - sound power, A-4
    - sound pressure level (at operator position), A-4
  - backplane, A-6
    - 10 MHz system reference clock (PXI\_CLK10), A-7
    - 100 MHz Reference Out BNC, A-7
    - 100 MHz system reference clock (PXIe\_CLK100 and PXIe\_SYNC100), A-7
  - CE compliance, A-5
  - chassis cooling, A-3
  - dimensions (figure), A-10, A-11
  - electrical, DC output, A-1
  - electromagnetic compatibility, A-5
  - environmental
    - management, A-6
    - operating environment, A-3
    - storage environment, A-4
  - external clock source, A-8
  - mechanical, A-9
  - online product certification, A-6
  - PXI differential star triggers (PXIe-DSTARA, PXIe-DSTARB, PXIe-DSTARC), A-8
  - PXI star trigger, A-8
  - PXIe\_SYNC\_CTRL, A-8
  - rack mount kit dimensions (figure), A-12
  - safety, A-5
  - shock and vibration, A-4
  - system reference clocks, A-7
  - Waste Electrical and Electronic Equipment (WEEE), A-6

- static discharge damage (caution), 3-1
- support, technical, D-2
- system configuration file, 2-17
- system controller slot
  - description, 1-6
  - pinouts
    - XP1 connector (table), B-2
    - XP2 connector (table), B-2
    - XP3 connector (table), B-3
    - XP4 connector (table), B-3
- system reference clock, 1-10
  - default behavior (figure), 1-10
  - specifications, A-7
- system timing slot
  - description, 1-8
  - pinouts
    - TP1 connector (table), B-4
    - TP2 connector (table), B-5
    - XP3 connector (table), B-5
    - XP4 connector (table), B-6

## T

- technical support, D-2
- testing power up, 2-6
- training and certification (NI resources), D-2
- trigger bus, 1-9
- trigger bus, routing (figure), 1-10
- troubleshooting (NI resources), D-2

## U

- unpacking the PXIe-1086 chassis, 1-1

## W

- Waste Electrical and Electronic Equipment (WEEE) specifications, A-6
- Web resources, D-2