

COMPREHENSIVE SERVICES

We offer competitive repair and calibration services, as well as easily accessible documentation and free downloadable resources.

SELL YOUR SURPLUS

We buy new, used, decommissioned, and surplus parts from every NI series. We work out the best solution to suit your individual needs.

 Sell For Cash  Get Credit  Receive a Trade-In Deal

OBSOLETE NI HARDWARE IN STOCK & READY TO SHIP

We stock **New**, **New Surplus**, **Refurbished**, and **Reconditioned** NI Hardware.



Bridging the gap between the manufacturer and your legacy test system.

 1-800-915-6216

 www.apexwaves.com

 sales@apexwaves.com

All trademarks, brands, and brand names are the property of their respective owners.

Request a Quote

 **CLICK HERE**

PXIe-5663

Vector Signal Analyzer

NI PXIe-5663, NI PXIe-5663E

- 10 MHz to 6.6 GHz frequency range
- 50 MHz instantaneous bandwidth (3 dB)
- ± 0.35 dB typical flatness within 20 MHz bandwidth
- ± 0.65 dB typical amplitude accuracy
- < -158 dBm/Hz typical display averaged noise level at 1 GHz
- 80 dB typical SFDR
- 112 dBc/Hz typical phase noise at 10 kHz offset at 1 GHz
- 16-bit ADC
- Full bandwidth streaming to disk (75 MS/s)
- RF List Mode support for NI PXIe-5663E

Operating System

- Windows 7/Vista/XP/2000

Included Software

- NI Spectral Measurements Toolkit
- NI Modulation Toolkit
- NI-RFSA driver

Programming API

- LabVIEW
- LabVIEW Real-Time
- LabWindows™/CVI
- C++/.NET



Overview

NI PXIe-5663 and PXIe-5663E 6.6 GHz RF vector signal analyzers offer wide instantaneous bandwidth optimized for automated test. Combined with high-performance PXI controllers and the high-speed PCI Express data bus, these modules can perform common automated measurements significantly faster than traditional instruments. You can use an NI PXIe-5663/5663E as either a spectrum analyzer or vector signal analyzer with NI LabVIEW or LabWindows/CVI software. In addition, you can use both the NI PXIe-5663 and PXI-5663E modules with the NI Modulation Toolkit for LabVIEW to analyze custom and standard modulation formats.

When combined with NI or third-party analysis toolkits, the NI PXIe-5663/5663E can perform measurements for a broad range of communications standards such as GSM, EDGE, WCDMA, WiMAX, LTE, Bluetooth, WLAN, DVB-C/H/T, ATSC, and MediaFLO. Because all measurements are software-defined, you can simply reconfigure the measurements using standard specific toolkits. With these toolkits, the NI PXIe-5663/5663E modules provide a low-cost solution to high-performance RF measurements.

Basic Architecture

As single-stage RF vector signal analyzers, the NI PXIe-5663/5663E modules are ideally suited for automated RF measurements when directly cabled to the device under test (DUT). You can use an NI PXIe-5663/5663E to perform fast and accurate RF measurements in design validation and manufacturing test applications.

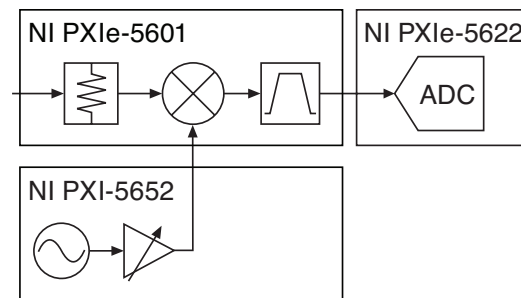

Figure 1. Block Diagram of an NI PXIe-5663

As illustrated in Figure 1, the NI PXIe-5601 RF downconverter module downconverts an RF signal to an intermediate frequency (IF). The local oscillator (LO) source is an NI PXI-565x RF continuous wave (CW) source, which uses a voltage-controlled oscillator (VCO) architecture for fast-frequency tuning speeds. Using a VCO, the NI PXIe-5663 is able to retune and measure signals in 11 ms or less. The NI PXIe-5622, which is used as an IF digitizer, features a 16-bit, 150 MS/s analog-to-digital converter (ADC).

The NI PXIe-5622 is based on a common synchronization architecture found in many NI PXI modular instruments. Thus, you can share timing and trigger signals between the NI PXIe-5663 and other PXI modular instruments.

Enhanced Architecture

The NI PXIe-5663E (E for enhanced) provides additional performance and features including RF List Mode support and configurable loop bandwidth for decreased tuning times. Like the NI PXIe-5663, the NI PXIe-5663E comprises three modular instruments. The enhanced NI PXIe-5601 RF downconverter module downconverts an RF signal to an IF signal, which is digitized with the

Vector Signal Analyzer

enhanced NI PXIe-5622, a 16-bit, 150 MS/s ADC module. You downconvert the signal from RF by using an NI PXIe-565x RF CW source as an LO.

With the enhanced NI PXIe-5663E, you can configure a wide- or narrow-loop bandwidth for the VCO of the NI PXIe-5652. By using a wide-loop bandwidth, you increase tuning time at the expense of additional phase noise; if you require lower phase noise over faster tuning times for a particular measurement, you can specify a narrow phase-locked loop (PLL) bandwidth for best performance. You can achieve tuning times of less than 450 μ s to under 0.1 ppm of the final frequency when using the wide-loop bandwidth configuration.

Fast Measurement Speed

Using software-defined measurements in LabVIEW with an NI PXIe-5663/5663E, you can perform common spectral and modulation measurements up to 30 times faster than traditional instruments.

You can also perform common spectrum analysis measurements quickly due to the processing power of multicore CPUs. For example, you can perform a 50 MHz spectrum sweep in 6 ms with an NI PXIe-8106 embedded controller (30 kHz RBW). While actual performance is system-dependent, Figure 2 illustrates the relationship between measurement time and resolution bandwidth (RBW) for a 50 MHz spectrum.

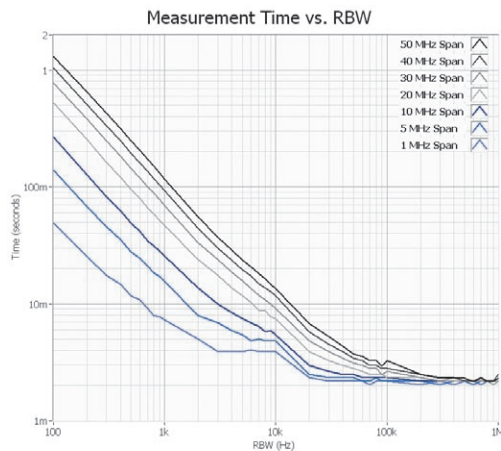

Figure 2. Measurement Time versus Resolution Bandwidth for a 50 MHz Spectrum

Note that for spans of less than 50 MHz – the NI PXIe-5663/5663E instantaneous bandwidth – spectrum sweep time is completely independent of the center frequency you choose.

In addition to spectrum sweeps, you can perform standard-specific modulation and spectral measurements significantly faster than traditional RF spectrum analyzers. Table 1 shows the nominal measurement times for measurements such as complementary cumulative distribution function (CCDF), error vector magnitude (EVM), adjacent channel power (ACP), and occupied bandwidth (OBW).

PXI Controller	NI PXIe-8130	NI PXIe-8106
CCDF (1M sample)	488 ms	330 ms
EVM	39.7 ms	28.3 ms
ACP	8.8 ms	8.2 ms
OBW	9.8 ms	8.9 ms

Table 1. Typical Measurement Times for the NI PXIe-8130 and PXIe-8106 Embedded Controllers

For the data in Table 1, the EVM measurement was performed on 2,600 symbols, with modulation settings configured to QPSK, a symbol rate of 3.84 MS/s, and a root raised cosine filter with an alpha of 0.22. The adjacent channel power measurement was performed on both the lower and upper adjacent and alternate channels. A channel bandwidth of 3.84 MHz was used, with channel spacing set to 5 MHz.

As the results above illustrate, an NI PXIe-5663/5663E combined with a multicore embedded PXI Express controller is able to perform measurements significantly faster than traditional instrumentation. In fact, you can perform most measurements up to 30 times faster than with traditional instruments.

RF List Mode

The NI PXIe-5663E provides RF List Mode support for fast and deterministic RF configuration changes. You supply a configuration list, and the RF modules proceed through the list without additional interaction with the host system and driver. This makes the configuration changes deterministic. Figure 3 illustrates this determinism with a single tone at 1 GHz stepping through six power levels in 7 dB steps starting with -10 dBm and ending with -45 dBm and a 500 μ s dwell time specified for each step.

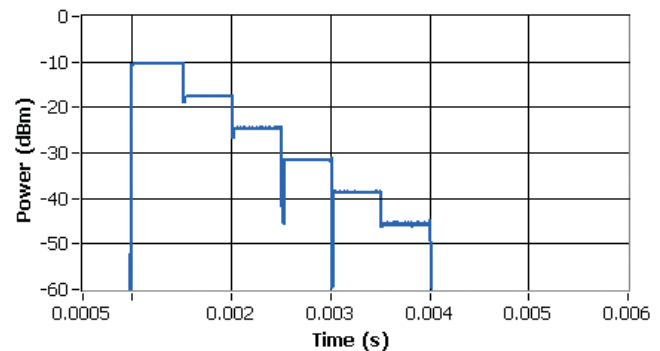

Figure 3. Deterministic 500 μ s Power Steps Using the NI PXIe-5663E and RF List Mode

You can use the NI PXIe-5663E in both open- and closed-loop scenarios to specify the source for the configuration trigger that advances from one configuration to the next. In an open-loop situation, the NI PXIe-5663E advances through the list based on a user-defined time specification for each step. The closed-loop scenario relies on an external trigger that may be provided by the DUT to advance through the RF configuration list.

Vector Signal Analyzer

RF Record and Playback

You can combine an NI PXIe-5663/5663E RF vector signal analyzer with a PXI RF vector signal generator for record and playback applications. In this application, you use an NI PXIe-5663/5663E to continuously record an RF signal as a file on a redundant array of inexpensive disks (RAID) volume. Then you use an RF vector signal generator to stream the recorded waveform from disk. With a 2 TB RAID volume, an NI PXIe-5663/5663E can be used to stream 50 MHz of RF bandwidth continuously to disk for more than 1.5 hours.

Because of the vector signal analyzer's PCI Express data bus, you can also use multiple analyzers to stream data to disk. With more than 1 GB/s of total system bandwidth, you can stream more than 100 MHz continuously to disk using multiple analyzers.

Phase-Coherent Analysis

The flexibility of the NI PXIe-5663/5663E modules enables multiple instruments to share a common start trigger, a reference clock, and even an LO. As a result, you can synchronize at least four NI PXIe-5663/5663E RF vector signal analyzers for phase-coherent acquisition. A block diagram of two synchronized analyzers is shown in Figure 4.

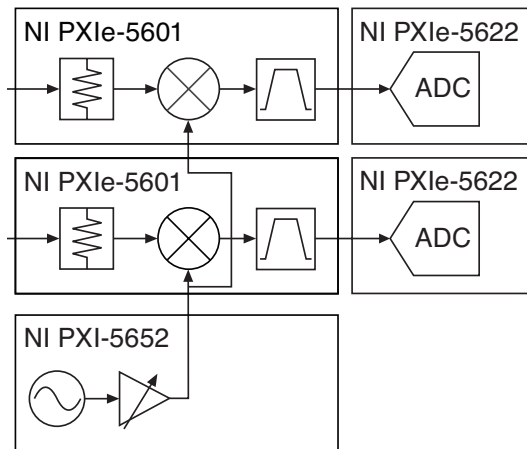

Figure 4. Simplified Block Diagram of Cascaded NI PXIe-5663 RF Vector Signal Analyzers

As shown in Figure 4, the NI PXIe-5601 RF downconverter both accepts and distributes a buffered LO. In this configuration, you can synchronize up to four analyzer channels without significant degradation of RF performance.

High-Performance RF Measurements

Using a 16-bit ADC with a high-performance RF front end, NI PXIe-5663/5663E modules offer up to 80 dB of spurious-free dynamic range (SFDR). Thus, you can perform spectrum analysis measurements that require high dynamic range. In Figure 5, an ACP measurement of a QPSK modulated signal is shown.

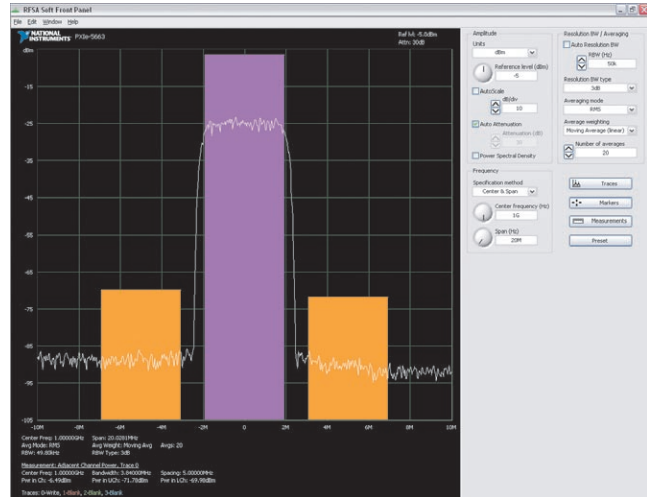

Figure 5. ACP Measurement of a QPSK Signal

This example uses a 3.84 MS/s symbol rate and a root raised cosine filter with an alpha of 0.22. A filter length of 128 symbols was implemented. The stimulus used in this measurement was programmed to an RF power level of -5 dBm. As Figure 5 shows, you can use an NI PXIe-5663/5663E to measure up to -65 dBc of adjacent channel rejection with the described settings.

In addition, with the high dynamic range and phase noise performance of the NI PXIe-5663/5663E modules, you can analyze higher-order modulation schemes such as 256-QAM. A loopback configuration with NI PXIe-5673/5673E RF vector signal generators and an NI PXIe-5663/5663E yields a nominal EVM (RMS) measurement of 0.5 percent. The constellation plot is shown in Figure 6.

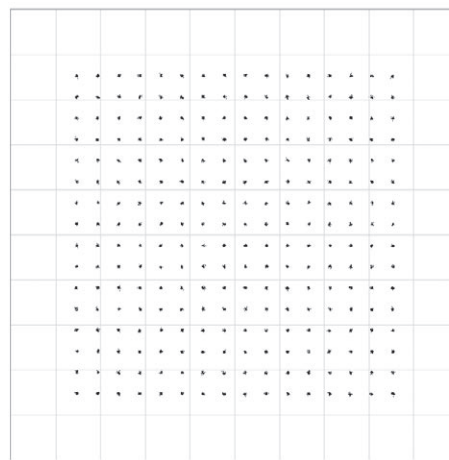

Figure 6. Constellation Plot of 256-QAM

The settings used in Figure 6 include a center frequency of 1 GHz, a 5.36 MS/s symbol rate, and a 0.12 root raised cosine filter alpha. The test stimulus was generated with the NI PXIe-5673 using the same symbol rate and filter alpha settings at an RF power level at -10 dBm.

Vector Signal Analyzer

Flexible Software

Programmed with the NI-RFSA instrument driver, NI PXIe-5663/5663E RF vector signal analyzers can be used in a variety of applications. The driver enables both high-level and low-level control of a variety of instrument settings. Figure 7 features a simple LabVIEW example showing basic spectrum acquisition.

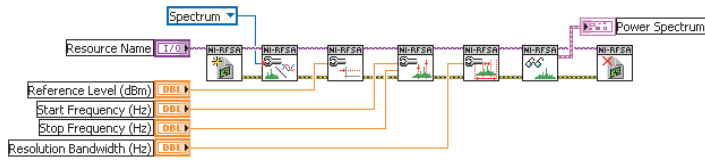

Figure 7. LabVIEW Example for Spectrum Sweep

The NI-RFSA driver includes an out-of-the-box soft front panel, which is shown in Figure 8.

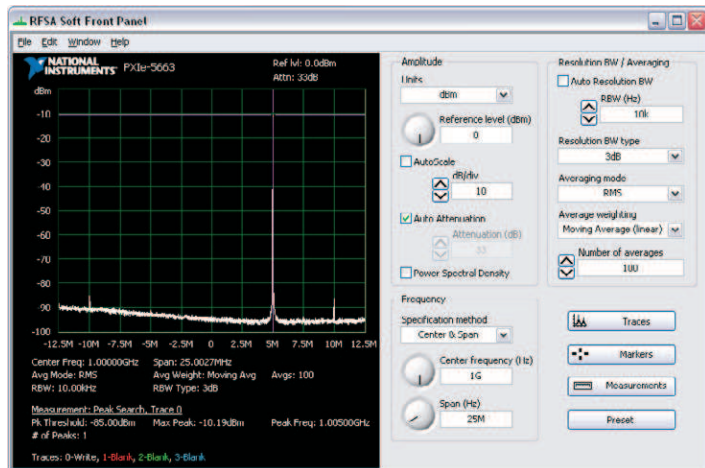

Figure 8. NI-RFSA Soft Front Panel

The NI PXIe-5663/5663E is shipped with two NI toolkits in addition to the NI-RFSA driver, the NI Modulation Toolkit, and the NI Spectral Measurements Toolkit.

With the Spectral Measurements Toolkit for LabVIEW and LabWindows/CVI, you can perform common measurements such as power spectrum, peak power and frequency, in-band power, adjacent channel power, and occupied bandwidth. In addition, the NI Modulation Toolkit for LabVIEW provides tools for vector signal analyzers. With this toolkit, you can perform measurements on a wide variety of modulated signals including schemes such as AM, FM, ASK, FSK, PSK, CPM, MSK, and QAM. In addition, the toolkit computes modulation accuracy measurements such as EVM, MER, rho, and others.

Ordering Information

NI PXIe-5663E

64 MB onboard memory.....	781260-01
256 MB onboard memory.....	781260-02

NI PXIe-5663

64 MB onboard memory.....	780415-01
256 MB onboard memory.....	780415-02

Phase Coherent VSAs

NI PXIe-5663/5663E VSA channel extension kit	780486-01
NI PXIe-5663E two-channel VSA	781339-02
NI PXIe-5663E three-channel VSA.....	781339-03
NI PXIe-5663E four-channel VSA	781339-04

BUY NOW

For complete product specifications, pricing, and accessory information, call 800 813 3693 (U.S.) or go to ni.com/pxi.

Vector Signal Analyzer

Specifications

Frequency

Frequency range¹..... 10 MHz to 6.6 GHz

Tuning resolution..... 533 nHz

¹ An NI 5663 is operational to 1 MHz. The maximum tuned frequency = 6.6 GHz – ½ (frequency span).

Bandwidth

Equalized Bandwidth

Tuned Frequency	Equalized Bandwidth (MHz)
10 MHz to <120 MHz	10
120 MHz to <330 MHz	20
330 MHz to 6.6 GHz	50

Note: Using automatic calibration correction through the NI-RFSA instrument driver.

Resolution Bandwidth

3 dB bandwidth..... Fully adjustable (<1 Hz to 10 MHz)

Selectivity

Window	60 dB: 3 dB Ratio
Flat Top	2.5, maximum
7-term Blackman-Harris	4.1, maximum

Note: The NI-RFSA instrument driver also supports additional window types.

Spectral Purity

Phase Noise

Single Sideband (SSB) Phase Noise	
Tuned Frequency	Noise Density
100 MHz	<-125 dBc/Hz
500 MHz	<-112 dBc/Hz
1 GHz	<-105 dBc/Hz
2 GHz	<-98 dBc/Hz
3 GHz	<-95 dBc/Hz
4 GHz	<-93 dBc/Hz
5 GHz	<-90 dBc/Hz
6.6 GHz	<-90 dBc/Hz

Note: 10 kHz offset; measured using an NI 5652 with an internal reference clock.

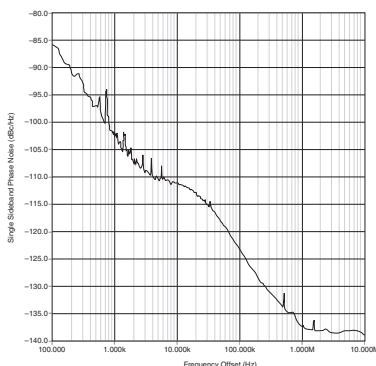

Figure 1. Typical Phase Noise at 1 GHz

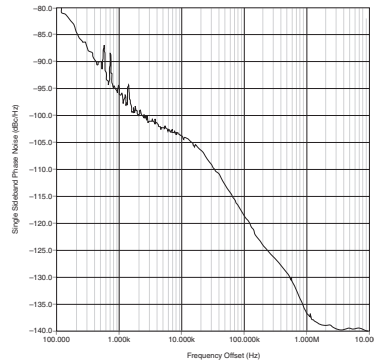

Figure 2. Typical Phase Noise at 2.4 GHz

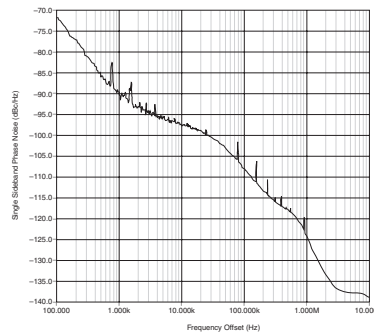

Figure 3. Typical Phase Noise at 5.8 GHz

Absolute Accuracy

Frequency	Accuracy	
	23 °C ± 5 °C	0 °C to 55 °C ¹
10 MHz to <120 MHz	±2.2 dB (±1.4 dB, typical)	±2.3 dB (±1.5 dB, typical)
120 MHz to <400 MHz	±1.7 dB (±0.65 dB, typical)	±1.8 dB (±0.75 dB, typical)
400 MHz to <3.0 GHz	±1.6 dB (±0.65 dB, typical)	±1.8 dB (±0.75 dB, typical)
3.0 GHz to <5.5 GHz	±1.7 dB (±0.65 dB, typical)	±1.8 dB (±0.75 dB, typical)
5.5 GHz to 6.6 GHz	±1.6 dB (±0.65 dB, typical)	±2.0 dB (±1.0 dB, typical)

Note: RF attenuation ≥8 dB; signal-to-noise ratio ≥20 dB.

¹Using automatic calibration correction of the NI-RFSA instrument driver, within ±5 °C of a self-calibration by the niRFSA Self Cal VI or the niRFSA_SelfCal function.

Linearity

Third-Order Intermodulation Distortion (Input IP₃ (IIP₃))

(Typical)

-20 dBm Reference Level	
Frequency Range	Input IP ₃
10 MHz to <30 MHz	≥5 dBm
30 MHz to <330 MHz	≥7 dBm
330 MHz to <3.0 GHz	≥12 dBm
3.0 GHz to 6.6 GHz	≥9 dBm

Note: Two -24 dBm input tones = 200 kHz apart.

Vector Signal Analyzer

0 dBm Reference Level	
Frequency Range	Input IP ₃
10 MHz to <30 MHz	≥21 dBm
30 MHz to <330 MHz	≥18 dBm
330 MHz to <3.0 GHz	≥21 dBm
3.0 GHz to 6.6 GHz	≥21 dBm

Note: Two -4 dBm input tones = 200 kHz apart.

Dynamic Range¹

Dynamic Range (Noise and Third-Order Intermodulation Distortion (IMD3))

(Nominal)

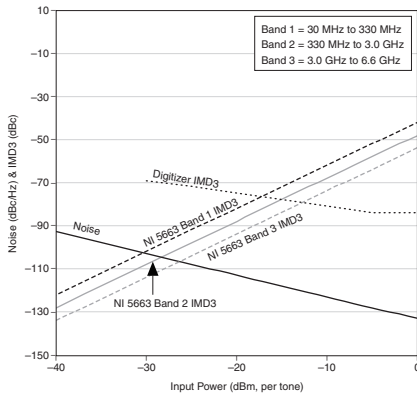

Figure 4. NI 5663 Vector Signal Analyzer Nominal Dynamic Range, 0 dBm Reference Level

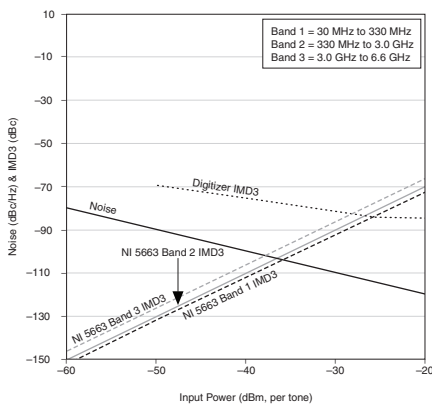

Figure 5. NI 5663 Vector Signal Analyzer Nominal Dynamic Range, -20 dBm Reference Level

¹Reference level allows 10 dB headroom for single-tone input signals before digitizer clipping occurs.

The dynamic range plots in the two preceding figures show nominal performance with NI-RFSA automatic coupled settings that are optimized for noise performance. If you use the RF attenuation manual settings, IMD3 performance can improve with minimal degradation in noise floor, thus increasing the effective SFDR in the power per tone signal range of 10 to 0 dB below reference level.

IF Flatness

(Typical)

IF Amplitude Flatness, 23 °C ± 5 °C		
Tuned Frequency	Bandwidth	Amplitude Flatness
10 MHz to <75 MHz	5 MHz	±0.25 dB
	10 MHz	±0.3 dB
75 MHz to <120 MHz	5 MHz	±0.4 dB
	10 MHz	±0.6 dB
120 MHz to <140 MHz	5 MHz	±0.45 dB
	10 MHz	±0.65 dB
	20 MHz	±0.9 dB
140 MHz to <330 MHz	5 MHz	±0.2 dB
	10 MHz	±0.4 dB
330 MHz to <6.6 GHz	10 MHz	±0.5 dB
	20 MHz	±0.2 dB
	50 MHz	±0.35 dB

Notes: RF attenuation ≥8 dB, 18 to 28 °C, with calibration correction; bandwidth centered about tuned frequency. Typical represents the worst ripple expected for any reference level setting across the specified frequency range.

IF Amplitude Flatness, 0 to 55 °C		
Tuned Frequency	Bandwidth	Amplitude Flatness
10 MHz to <75 MHz	5 MHz	±0.3 dB
	10 MHz	±0.45 dB
75 MHz to <120 MHz	5 MHz	±0.35 dB
	10 MHz	±0.6 dB
120 MHz to <140 MHz	5 MHz	±0.55 dB
	10 MHz	±0.85 dB
	20 MHz	±1.1 dB
140 MHz to <330 MHz	5 MHz	±0.35 dB
	10 MHz	±0.8 dB
330 MHz to <6.6 GHz	10 MHz	±0.8 dB
	20 MHz	±0.25 dB
	50 MHz	±0.4 dB

Notes: RF attenuation ≥8 dB, 0 to 55 °C, with calibration correction; bandwidth about tuned frequency. Typical represents the worst ripple expected for any reference level setting across the specified frequency range.

Vector Signal Analyzer

Error Vector Magnitude (EVM) and Modulation Error Ratio (MER)

(Nominal)

Data length in the following three tables is 1,250 symbols pseudorandom bit sequence (PRBS) at -30 dBm power level. These results were obtained using the NI 5663 onboard clock (the NI 5652 LO source onboard clock) and do not include software equalization using the NI Modulation Toolkit. Results are the composite effect of both an NI 5663 vector signal analyzer and an NI 5673 RF vector signal generator.

825 MHz Carrier Frequency				
QAM Order	Symbol Rate (kS/s)	-RRC	EVM (% RMS)	MER (dB)
M = 4	160	0.25	0.3	52
	800	0.25	0.4	49
	4,090	0.22	0.5	46
M = 16	17,600	0.25	0.7	41
	32,000	0.25	1.0	37
M = 64	5,360	0.15	0.4	44
	6,952	0.15	0.5	43
	40,990	0.22	1.1	35
M = 256	6,952	0.15	0.4	43

3.4 GHz Carrier Frequency				
QAM Order	Symbol Rate (kS/s)	-RRC	EVM (% RMS)	MER (dB)
M = 4	160	0.25	0.65	44
	800	0.25	0.65	44
	4,090	0.22	0.74	43
M = 16	17,600	0.25	1.13	36
	32,000	0.25	1.94	32
M = 64	5,360	0.15	0.59	41
	6,952	0.15	0.66	40
	40,990	0.22	2.15	30
M = 256	6,952	0.15	0.64	40

5.8 GHz Carrier Frequency				
QAM Order	Symbol Rate (kS/s)	-RRC	EVM (% RMS)	MER (dB)
M = 4	160	0.25	0.89	41
	800	0.25	0.85	41
	4,090	0.22	1.04	40
M = 16	17,600	0.25	1.49	34
	32,000	0.25	2.00	31
M = 64	5,360	0.15	0.83	38
	6,952	0.15	0.90	37
	40,990	0.22	2.06	30
M = 256	6,952	0.15	1.00	36

NI Services and Support



NI has the services and support to meet your needs around the globe and through the application life cycle – from planning and development through deployment and ongoing maintenance. We offer services and service levels to meet customer requirements in research, design, validation, and manufacturing.

Visit ni.com/services.

Training and Certification

NI training is the fastest, most certain route to productivity with our products. NI training can shorten your learning curve, save development time, and reduce maintenance costs over the application life cycle. We schedule instructor-led courses in cities worldwide, or we can hold a course at your facility. We also offer a professional certification program that identifies individuals who have high levels of skill and knowledge on using NI products.

Visit ni.com/training.

Professional Services

Our NI Professional Services team is composed of NI applications and systems engineers and a worldwide National Instruments Alliance Partner program of more than 600 independent consultants and integrators. Services range from

start-up assistance to turnkey system integration. Visit ni.com/alliance.



OEM Support

We offer design-in consulting and product integration assistance if you want to use our products for OEM applications. For information about special pricing and services for OEM customers, visit ni.com/oem.



ni.com ■ 800 813 3693

National Instruments ■ info@ni.com

Local Sales and Technical Support

In offices worldwide, our staff is local to the country, giving you access to engineers who speak your language. NI delivers industry-leading technical support through online knowledge bases, our applications engineers, and access to 14,000 measurement and automation professionals within NI Developer Exchange forums. Find immediate answers to your questions at ni.com/support.

We also offer service programs that provide automatic upgrades to your application development environment and higher levels of technical support. Visit ni.com/ssp.

Hardware Services

System Assurance Programs

NI system assurance programs are designed to make it even easier for you to own an NI system. These programs include configuration and deployment services for your NI PXI, CompactRIO, or Compact FieldPoint system. The NI Basic System Assurance Program provides a simple integration test and ensures that your system is delivered completely assembled in one box. When you configure your system with the NI Standard System Assurance Program, you can select from available NI system driver sets and application development environments to create customized, reorderable software configurations. Your system arrives fully assembled and tested in one box with your software preinstalled. When you order your system with the standard program, you also receive system-specific documentation including a bill of materials, an integration test report, a recommended maintenance plan, and frequently asked question documents. Finally, the standard program reduces the total cost of owning an NI system by providing three years of warranty coverage and calibration service. Use the online product advisors at ni.com/advisor to find a system assurance program to meet your needs.

Calibration Services

NI recognizes the need to maintain properly calibrated devices for high-accuracy measurements. We provide manual calibration procedures, services to recalibrate your products, and automated calibration software specifically designed for use by metrology laboratories. Visit ni.com/calibration.

Repair and Extended Warranty

NI provides complete repair services for our products. Express repair and advance replacement services are also available. We offer extended warranties to help you meet project life-cycle requirements. Visit ni.com/services.