

COMPREHENSIVE SERVICES

We offer competitive repair and calibration services, as well as easily accessible documentation and free downloadable resources.

SELL YOUR SURPLUS

We buy new, used, decommissioned, and surplus parts from every NI series. We work out the best solution to suit your individual needs.

 Sell For Cash  Get Credit  Receive a Trade-In Deal

OBSOLETE NI HARDWARE IN STOCK & READY TO SHIP

We stock **New**, **New Surplus**, **Refurbished**, and **Reconditioned** NI Hardware.



Bridging the gap between the manufacturer and your legacy test system.

 1-800-915-6216

 www.apexwaves.com

 sales@apexwaves.com

All trademarks, brands, and brand names are the property of their respective owners.

Request a Quote

 **CLICK HERE**

PXIe-7856

GETTING STARTED GUIDE

NI PXIe-7856R

R Series Reconfigurable I/O Module (AI, AO, DIO) for PXI Express, 8 AI, 8 AO, 48 DIO, 1 MS/s AI, Kintex-7 160T FPGA

This document describes how to begin using the NI PXIe-7856R.

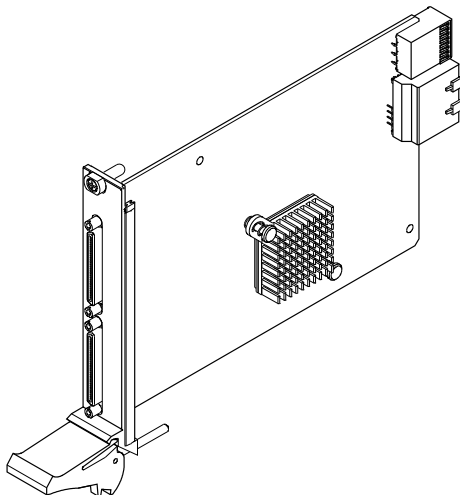

Safety Guidelines



Caution Do not operate the NI PXIe-7856R in a manner not specified in this document. Product misuse can result in a hazard. You can compromise the safety protection built into the product if the product is damaged in any way. If the product is damaged, return it to NI for repair.

Electromagnetic Compatibility Guidelines

This product was tested and complies with the regulatory requirements and limits for electromagnetic compatibility (EMC) stated in the product specifications. These requirements and limits provide reasonable protection against harmful interference when the product is operated in the intended operational electromagnetic environment.

This product is intended for use in industrial locations. However, harmful interference may occur in some installations, when the product is connected to a peripheral device or test object, or if the product is used in residential or commercial areas. To minimize interference with radio and television reception and prevent unacceptable performance degradation, install and use this product in strict accordance with the instructions in the product documentation.

Furthermore, any changes or modifications to the product not expressly approved by National Instruments could void your authority to operate it under your local regulatory rules.



Caution To ensure the specified EMC performance, operate this product only with shielded cables and accessories.



Caution To ensure the specified EMC performance, the length of all I/O cables must be no longer than 3 m (10 ft).

Preparing the Environment

Ensure that the environment in which you are using the NI PXIe-7856R meets the following specifications.

Operating temperature (IEC 60068-2-1, IEC 60068-2-2)	0 °C to 55 °C
Operating humidity (IEC 60068-2-56)	10% RH to 90% RH, noncondensing
Pollution degree	2
Maximum altitude	2,000 m

Indoor use only.



Note Refer to the device specifications on ni.com/manuals for complete specifications.

Unpacking the Kit



Caution To prevent electrostatic discharge (ESD) from damaging the device, ground yourself using a grounding strap or by holding a grounded object, such as your computer chassis.

1. Touch the antistatic package to a metal part of the computer chassis.
2. Remove the device from the package and inspect the device for loose components or any other sign of damage.



Caution Never touch the exposed pins of connectors.



Note Do not install a device if it appears damaged in any way.

3. Unpack any other items and documentation from the kit.

Store the device in the antistatic package when the device is not in use.

Verifying the Kit Contents

Verify that the following items are included in the NI PXIe-7856R kit.

Figure 1. NI PXIe-7856R Kit Contents

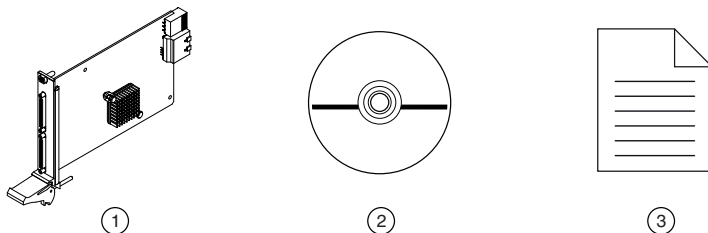

-
1. Hardware
 2. NI-RIO Media
 3. Getting Started Guide
-

Installing Software on the Host Computer

Before using the NI PXIe-7856R, you must install the following application software and device drivers on the host computer.

1. LabVIEW 2016 or later
2. LabVIEW Real-Time Module 2016 or later¹
3. LabVIEW FPGA Module 2016 or later
4. NI R Series Multifunction RIO Device Drivers August 2016 or later

Visit ni.com/info and enter the Info Code `softwareversion` for minimum software support information.

Installing the NI PXIe-7856R



Caution To prevent damage to the device caused by ESD or contamination, handle the device using the edges or the metal bracket.

1. Ensure the AC power source is connected to the chassis before installing the modules.

The AC power cord grounds the chassis and protects it from electrical damage while you install the modules.

¹ LabVIEW Real Time Module is only required when the R Series board is used in a chassis where the PXIe Controller is running a real-time operating system.

2. Power off the chassis.
3. Inspect the slot pins on the chassis backplane for any bends or damage prior to installation. Do not install a module if the backplane is damaged.
4. Remove the black plastic covers from all the captive screws on the module front panel.
5. Identify a supported slot in the chassis. The following figure shows the symbols that indicate the slot types.

Figure 2. Chassis Compatibility Symbols

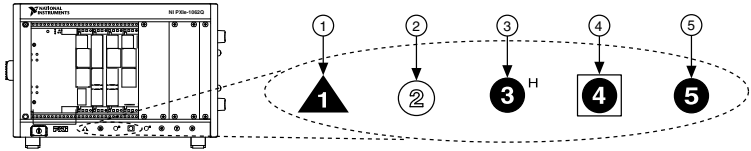

- | | |
|---------------------------------------|-----------------------------------|
| 1. PXI Express System Controller Slot | 4. PXI Express System Timing Slot |
| 2. PXI Peripheral Slot | 5. PXI Express Peripheral Slot |
| 3. PXI Express Hybrid Peripheral Slot | |

NI PXIe-7856R modules can be placed in PXI Express peripheral slots, PXI Express hybrid peripheral slots, or PXI Express system timing slots.

6. Touch any metal part of the chassis to discharge static electricity.
7. Place the module edges into the module guides at the top and bottom of the chassis. Slide the device into the slot until it is fully inserted.

Figure 3. Module Installation

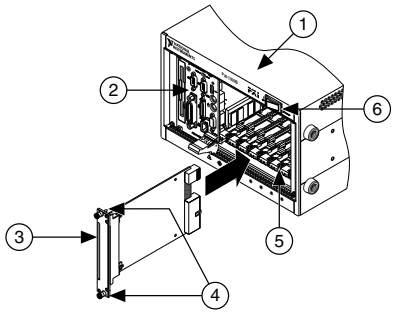

- | | |
|----------------------|--------------------------------|
| 1. Chassis | 4. Front-Panel Mounting Screws |
| 2. System Controller | 5. Module Guides |
| 3. Hardware Module | 6. Power Switch |

8. Secure the device front panel to the chassis using the front-panel mounting screws.

Note Tightening the top and bottom mounting screws increases mechanical stability and also electrically connects the front panel to the chassis, which can improve the signal quality and electromagnetic performance.

9. Cover all empty slots with filler panels or use slot blockers to maximize cooling air flow.

10. Power on the chassis.

Verifying Hardware Installation for Host Targets

You can verify that the system recognizes the NI PXIe-7856R by using Measurement & Automation Explorer (MAX).

1. Launch MAX by navigating to **Start»All Programs»National Instruments»MAX** or by clicking the MAX desktop icon.
2. Expand **Devices and Interfaces**.
3. Verify that the device appears under **Devices and Interfaces**.

If the device does not appear, press <F5> to refresh the view in MAX. If the device does not appear after refreshing the view, visit ni.com/support for troubleshooting information.

Verifying Hardware Installation for Remote Targets

You can verify that the system recognizes the NI PXIe-7856R by using Measurement & Automation Explorer (MAX).

1. Launch MAX on the host computer.
2. Expand **Remote Targets** in the configuration tree and locate your system.
3. Install LabVIEW Real-Time Module 2016 and NI RIO Device Drivers August 2016 or later on your **Remote Target**.
 - a) Refer to the *Installing Software on the Host Computer* section for information about installing software on the host.
 - b) Refer to the *PXI Express Controllers User Manual* at ni.com/manuals for information on installing software on the target.
4. Under **Remote Targets**, find and expand **Devices and Interfaces**.

If the device does not appear, press <F5> to refresh the view in MAX. If the device does not appear after refreshing the view, visit ni.com/support for troubleshooting information.

Pinout

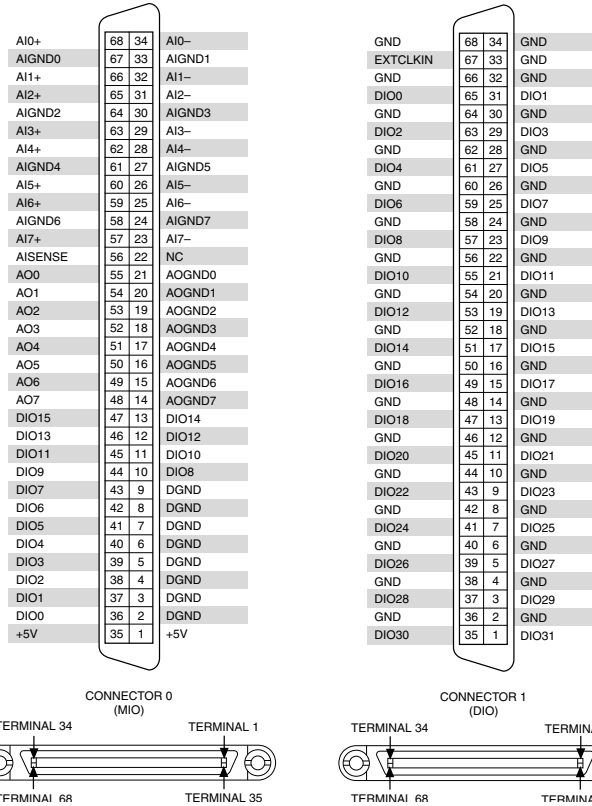

Table 1. NI PXIe-7856R Signal Descriptions

Signal	Description
AI+	Positive analog input signal connection
AI-	Negative analog input signal connection
AISENSE	Reference connection for NRSE measurements
AIGND	Ground reference for the analog input signal
AO	Analog output signal connection
AOGND	Ground reference for the analog output signal

Table 1. NI PXIe-7856R Signal Descriptions (Continued)

Signal	Description
DIO	Digital input/output signal connection
DGND	Ground reference for the digital signal
EXTCLKIN	External clock input source that can be used for source synchronous acquisitions. The provided clock source must be stable and glitch-free.
GND	Ground connection
Supply (+5 Vout)	5 V power output connection for external devices
NC	No connection

The NI PXIe-7856R is protected from overvoltage and overcurrent conditions.



Note Refer to the device specifications, available at ni.com/manuals for more information.

Where to Go Next

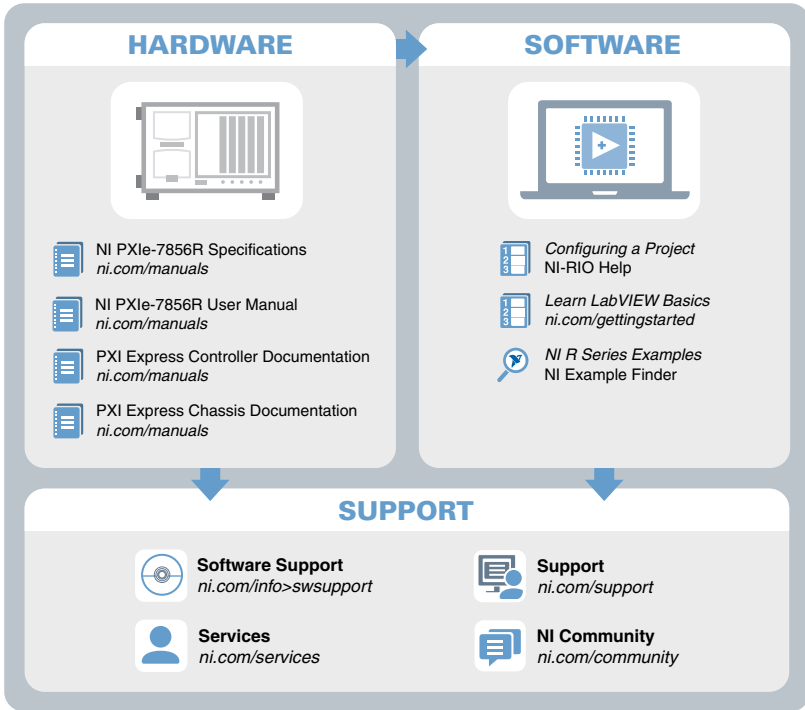

Worldwide Support and Services

The NI website is your complete resource for technical support. At ni.com/support, you have access to everything from troubleshooting and application development self-help resources to email and phone assistance from NI Application Engineers.

Visit ni.com/services for NI Factory Installation Services, repairs, extended warranty, and other services.

Visit ni.com/register to register your NI product. Product registration facilitates technical support and ensures that you receive important information updates from NI.

A Declaration of Conformity (DoC) is our claim of compliance with the Council of the European Communities using the manufacturer's declaration of conformity. This system affords the user protection for electromagnetic compatibility (EMC) and product safety. You can obtain the DoC for your product by visiting ni.com/certification. If your product supports calibration, you can obtain the calibration certificate for your product at ni.com/calibration.

NI corporate headquarters is located at 11500 North Mopac Expressway, Austin, Texas, 78759-3504. NI also has offices located around the world. For telephone support in the United States, create your service request at ni.com/support or dial 1 866 ASK MYNI (275 6964). For telephone support outside the United States, visit the *Worldwide Offices* section of ni.com/niglobal to access the branch office websites, which provide up-to-date contact information, support phone numbers, email addresses, and current events.

Refer to the *NI Trademarks and Logo Guidelines* at ni.com/trademarks for information on NI trademarks. Other product and company names mentioned herein are trademarks or trade names of their respective companies. For patents covering NI products/technology, refer to the appropriate location: **Help»Patents** in your software, the `patents.txt` file on your media, or the *National Instruments Patent Notice* at ni.com/patents. You can find information about end-user license agreements (EULAs) and third-party legal notices in the readme file for your NI product. Refer to the *Export Compliance Information* at ni.com/legal/export-compliance for the NI global trade compliance policy and how to obtain relevant HTS codes, ECCNs, and other import/export data. NI MAKES NO EXPRESS OR IMPLIED WARRANTIES AS TO THE ACCURACY OF THE INFORMATION CONTAINED HEREIN AND SHALL NOT BE LIABLE FOR ANY ERRORS. U.S. Government Customers: The data contained in this manual was developed at private expense and is subject to the applicable limited rights and restricted data rights as set forth in FAR 52.227-14, DFAR 252.227-7014, and DFAR 252.227-7015.

© 2016 National Instruments. All rights reserved.

378000B-01 May16