

COMPREHENSIVE SERVICES

We offer competitive repair and calibration services, as well as easily accessible documentation and free downloadable resources.

SELL YOUR SURPLUS

We buy new, used, decommissioned, and surplus parts from every NI series. We work out the best solution to suit your individual needs.

 Sell For Cash  Get Credit  Receive a Trade-In Deal

OBSOLETE NI HARDWARE IN STOCK & READY TO SHIP

We stock **New**, **New Surplus**, **Refurbished**, and **Reconditioned** NI Hardware.



Bridging the gap between the manufacturer and your legacy test system.

 1-800-915-6216

 www.apexwaves.com

 sales@apexwaves.com

All trademarks, brands, and brand names are the property of their respective owners.

Request a Quote

 **CLICK HERE**

PXIe-8388



MXI-Express x16 for PXI Express Series User Manual

MXI-Express for PXI Express: Multisystem eXtension Interface for PCI Express, CompactPCI Express, and PXI Express Bus Systems

NI PCIe-8388

NI PXIe-8388

NI PXIe-8389

Worldwide Technical Support and Product Information

ni.com

Worldwide Offices

Visit ni.com/niglobal to access the branch office Web sites, which provide up-to-date contact information, support phone numbers, email addresses, and current events.

National Instruments Corporate Headquarters

11500 North Mopac Expressway Austin, Texas 78759-3504 USA Tel: 512 683 0100

For further support information, refer to the *Technical Support and Professional Services* appendix. To comment on National Instruments documentation, refer to the National Instruments Web site at ni.com/info and enter the Info Code `feedback`.

Important Information

Warranty

The NI PCIe-8388 and NI PXIe-8388/9 are warranted against defects in materials and workmanship for a period of one year from the date of shipment, as evidenced by receipts or other documentation. National Instruments will, at its option, repair or replace equipment that proves to be defective during the warranty period. This warranty includes parts and labor.

The media on which you receive National Instruments software are warranted not to fail to execute programming instructions, due to defects in materials and workmanship, for a period of 90 days from date of shipment, as evidenced by receipts or other documentation. National Instruments will, at its option, repair or replace software media that do not execute programming instructions if National Instruments receives notice of such defects during the warranty period. National Instruments does not warrant that the operation of the software shall be uninterrupted or error free.

A Return Material Authorization (RMA) number must be obtained from the factory and clearly marked on the outside of the package before any equipment will be accepted for warranty work. National Instruments will pay the shipping costs of returning to the owner parts which are covered by warranty.

National Instruments believes that the information in this document is accurate. The document has been carefully reviewed for technical accuracy. In the event that technical or typographical errors exist, National Instruments reserves the right to make changes to subsequent editions of this document without prior notice to holders of this edition. The reader should consult National Instruments if errors are suspected. In no event shall National Instruments be liable for any damages arising out of or related to this document or the information contained in it.

EXCEPT AS SPECIFIED HEREIN, NATIONAL INSTRUMENTS MAKES NO WARRANTIES, EXPRESS OR IMPLIED, AND SPECIFICALLY DISCLAIMS ANY WARRANTY OF MERCHANTABILITY OR FITNESS FOR A PARTICULAR PURPOSE. CUSTOMER'S RIGHT TO RECOVER DAMAGES CAUSED BY FAULT OR NEGLIGENCE ON THE PART OF NATIONAL INSTRUMENTS SHALL BE LIMITED TO THE AMOUNT THEREFORE PAID BY THE CUSTOMER. NATIONAL INSTRUMENTS WILL NOT BE LIABLE FOR DAMAGES RESULTING FROM LOSS OF DATA, PROFITS, USE OF PRODUCTS, OR INCIDENTAL OR CONSEQUENTIAL DAMAGES, EVEN IF ADVISED OF THE POSSIBILITY THEREOF. This limitation of the liability of National Instruments will apply regardless of the form of action, whether in contract or tort, including negligence. Any action against National Instruments must be brought within one year after the cause of action accrues. National Instruments shall not be liable for any delay in performance due to causes beyond its reasonable control. The warranty provided herein does not cover damages, defects, malfunctions, or service failures caused by owner's failure to follow the National Instruments installation, operation, or maintenance instructions; owner's modification of the product; owner's abuse, misuse, or negligent acts; and power failure or surges, fire, flood, accident, actions of third parties, or other events outside reasonable control.

Copyright

Under the copyright laws, this publication may not be reproduced or transmitted in any form, electronic or mechanical, including photocopying, recording, storing in an information retrieval system, or translating, in whole or in part, without the prior written consent of National Instruments Corporation.

National Instruments respects the intellectual property of others, and we ask our users to do the same. NI software is protected by copyright and other intellectual property laws. Where NI software may be used to reproduce software or other materials belonging to others, you may use NI software only to reproduce materials that you may reproduce in accordance with the terms of any applicable license or other legal restriction.

Trademarks

LabVIEW, National Instruments, NI, ni.com, the National Instruments corporate logo, and the Eagle logo are trademarks of National Instruments Corporation. Refer to the *Trademark Information* at ni.com/trademarks for other National Instruments trademarks.

Other product and company names mentioned herein are trademarks or trade names of their respective companies.

Members of the National Instruments Alliance Partner Program are business entities independent from National Instruments and have no agency, partnership, or joint-venture relationship with National Instruments.

Patents

For patents covering National Instruments products/technology, refer to the appropriate location: **Help»Patents** in your software, the `patents.txt` file on your media, or the *National Instruments Patent Notice* at ni.com/patents.

Export Compliance Information

Refer to the *Export Compliance Information* at ni.com/legal/export-compliance for the National Instruments global trade compliance policy and how to obtain relevant HTS codes, ECCNs, and other import/export data.

WARNING REGARDING USE OF NATIONAL INSTRUMENTS PRODUCTS

(1) NATIONAL INSTRUMENTS PRODUCTS ARE NOT DESIGNED WITH COMPONENTS AND TESTING FOR A LEVEL OF RELIABILITY SUITABLE FOR USE IN OR IN CONNECTION WITH SURGICAL IMPLANTS OR AS CRITICAL COMPONENTS IN ANY LIFE SUPPORT SYSTEMS WHOSE FAILURE TO PERFORM CAN REASONABLY BE EXPECTED TO CAUSE SIGNIFICANT INJURY TO A HUMAN.

(2) IN ANY APPLICATION, INCLUDING THE ABOVE, RELIABILITY OF OPERATION OF THE SOFTWARE PRODUCTS CAN BE IMPAIRED BY ADVERSE FACTORS, INCLUDING BUT NOT LIMITED TO FLUCTUATIONS IN ELECTRICAL POWER SUPPLY, COMPUTER HARDWARE MALFUNCTIONS, COMPUTER OPERATING SYSTEM SOFTWARE FITNESS, FITNESS OF COMPILERS AND DEVELOPMENT SOFTWARE USED TO DEVELOP AN APPLICATION, INSTALLATION ERRORS, SOFTWARE AND HARDWARE COMPATIBILITY PROBLEMS, MALFUNCTIONS OR FAILURES OF ELECTRONIC MONITORING OR CONTROL DEVICES, TRANSIENT FAILURES OF ELECTRONIC SYSTEMS (HARDWARE AND/OR SOFTWARE), UNANTICIPATED USES OR MISUSES, OR ERRORS ON THE PART OF THE USER OR APPLICATIONS DESIGNER (ADVERSE FACTORS SUCH AS THESE ARE HEREAFTER COLLECTIVELY TERMED "SYSTEM FAILURES"). ANY APPLICATION WHERE A SYSTEM FAILURE WOULD CREATE A RISK OF HARM TO PROPERTY OR PERSONS (INCLUDING THE RISK OF BODILY INJURY AND DEATH) SHOULD NOT BE RELIANT SOLELY UPON ONE FORM OF ELECTRONIC SYSTEM DUE TO THE RISK OF SYSTEM FAILURE. TO AVOID DAMAGE, INJURY, OR DEATH, THE USER OR APPLICATION DESIGNER MUST TAKE REASONABLY PRUDENT STEPS TO PROTECT AGAINST SYSTEM FAILURES, INCLUDING BUT NOT LIMITED TO BACK-UP OR SHUT DOWN MECHANISMS. BECAUSE EACH END-USER SYSTEM IS CUSTOMIZED AND DIFFERS FROM NATIONAL INSTRUMENTS' TESTING PLATFORMS AND BECAUSE A USER OR APPLICATION DESIGNER MAY USE NATIONAL INSTRUMENTS PRODUCTS IN COMBINATION WITH OTHER PRODUCTS IN A MANNER NOT EVALUATED OR CONTEMPLATED BY NATIONAL INSTRUMENTS, THE USER OR APPLICATION DESIGNER IS ULTIMATELY RESPONSIBLE FOR VERIFYING AND VALIDATING THE SUITABILITY OF NATIONAL INSTRUMENTS PRODUCTS WHENEVER NATIONAL INSTRUMENTS PRODUCTS ARE INCORPORATED IN A SYSTEM OR APPLICATION, INCLUDING, WITHOUT LIMITATION, THE APPROPRIATE DESIGN, PROCESS AND SAFETY LEVEL OF SUCH SYSTEM OR APPLICATION.

Compliance

Electromagnetic Compatibility Information

This hardware has been tested and found to comply with the applicable regulatory requirements and limits for electromagnetic compatibility (EMC) as indicated in the hardware's Declaration of Conformity (DoC)¹. These requirements and limits are designed to provide reasonable protection against harmful interference when the hardware is operated in the intended electromagnetic environment. In special cases, for example when either highly sensitive or noisy hardware is being used in close proximity, additional mitigation measures may have to be employed to minimize the potential for electromagnetic interference.

While this hardware is compliant with the applicable regulatory EMC requirements, there is no guarantee that interference will not occur in a particular installation. To minimize the potential for the hardware to cause interference to radio and television reception or to experience unacceptable performance degradation, install and use this hardware in strict accordance with the instructions in the hardware documentation and the DoC¹.

If this hardware does cause interference with licensed radio communications services or other nearby electronics, which can be determined by turning the hardware off and on, you are encouraged to try to correct the interference by one or more of the following measures:

- Reorient the antenna of the receiver (the device suffering interference).
- Relocate the transmitter (the device generating interference) with respect to the receiver.
- Plug the transmitter into a different outlet so that the transmitter and the receiver are on different branch circuits.

Some hardware may require the use of a metal, shielded enclosure (windowless version) to meet the EMC requirements for special EMC environments such as, for marine use or in heavy industrial areas. Refer to the hardware's user documentation and the DoC¹ for product installation requirements.

When the hardware is connected to a test object or to test leads, the system may become more sensitive to disturbances or may cause interference in the local electromagnetic environment.

Operation of this hardware in a residential area is likely to cause harmful interference. Users are required to correct the interference at their own expense or cease operation of the hardware.

Changes or modifications not expressly approved by National Instruments could void the user's right to operate the hardware under the local regulatory rules.

¹ The Declaration of Conformity (DoC) contains important EMC compliance information and instructions for the user or installer. To obtain the DoC for this product, visit ni.com/certification, search by model number or product line, and click the appropriate link in the Certification column.

Contents

About This Manual

Conventions	vii
Related Documentation.....	viii

Chapter 1 Introduction

About the MXI-Express x16 Series	1-1
Description and Features	1-1
Basic MXI-Express x16 System.....	1-2
Larger MXI-Express x16 Systems	1-2
What You Need to Get Started	1-3
Unpacking	1-3

Chapter 2 Hardware Installation

Hardware Installation.....	2-1
Installing an NI PCIe-8388.....	2-1
Installing an NI PXIe-8388/9	2-2
Cabling	2-4
Using the Daisy Chain Topology	2-4
Powering On the MXI-Express x16 System	2-5
Powering Off the MXI-Express x16 System.....	2-5

Chapter 3 Hardware Overview

Functional Overview.....	3-1
Functional Unit Descriptions	3-2
PCI Express x16 Board Edge Connector.....	3-2
PCI Express Switch	3-2
Cabled MXI-Express x16 Connector	3-3
PCI Express-to-PCI Bridge	3-3
SMBus Master	3-3
LED Indicators.....	3-3
Cable Options	3-4

**Appendix A
Specifications**

**Appendix B
Technical Support and Professional Services**

Index

About This Manual

This manual describes the features, functions, and operation of the MXI-Express x16 for PXI Express series of products. The products in this series are the NI PCIe-8388, NI PXIe-8388, and NI PXIe-8389.

Conventions

The following conventions appear in this manual:

» The » symbol leads you through nested menu items and dialog box options to a final action. The sequence **Options»Settings»General** directs you to pull down the **Options** menu, select the **Settings** item, and select **General** from the last dialog box.



This icon denotes a note, which alerts you to important information.



This icon denotes a caution, which advises you of precautions to take to avoid injury, data loss, or a system crash.

bold Bold text denotes items that you must select or click in the software, such as menu items and dialog box options. Bold text also denotes parameter names.

italic Italic text denotes variables, emphasis, a cross-reference, or an introduction to a key concept. Italic text also denotes text that is a placeholder for a word or value that you must supply.

monospace Text in this font denotes text or characters that you should enter from the keyboard, sections of code, programming examples, and syntax examples. This font is also used for the proper names of disk drives, paths, directories, programs, subprograms, subroutines, device names, functions, operations, variables, filenames, and extensions.

CompactPCI Express/
CPCIe The terms *CompactPCI Express* and *CPCIe* are interchangeable in this manual.

PCI Express/PCIe The terms *PCI Express* and *PCIe* are interchangeable in this manual.

PXI Express chassis In this manual, whenever a PXI Express chassis is referenced, a CompactPCI Express chassis could be used instead.

PXI Express/PXIe The terms *PXI Express* and *PXIe* are interchangeable in this manual.

Related Documentation

The following documents contain information that you may find helpful as you read this manual:

- *Set Up Your MXI-Express System*
- Your computer or chassis documentation
- *PXI Express Hardware Specification, Revision 1.0*
- *PXI-2 PXI Software Specification, Revision 2.1*
- *PXI-6 PXI Express Software Specification*
- *PCI Specification, Revision 2.3*
- *PCI-PCI Bridge Architecture Specification, Revision 1.2*
- *PICMG CompactPCI Express EXP.0 R1.0 Specification*
- *PCI Express Specification, Revision 1.0a*

Introduction

This chapter describes the MXI-Express x16 series of products, lists what you need to get started, and explains how to unpack and set up your hardware.

The MXI-Express x16 series is an extension of the MXI-Express series of remote controllers from National Instruments. The products in this series are the NI PCIe-8388, NI PXIe-8388, and NI PXIe-8389.

About the MXI-Express x16 Series

Description and Features

MXI-Express x16 uses PCI Express signals over a cable of up to 3 m. You can do the following with MXI-Express x16:

- Control one or more PXI Express or CompactPCI Express chassis with a supported PCI Express-based PC.
- Physically separate the measurement or automation system from a host PC (up to 3 m).

Basic MXI-Express x16 System

The simplest MXI-Express x16 system consists of an NI PCIe-8388 in a supported PC connected to an NI PXIe-8388 in the controller slot of a PXI Express or CompactPCI Express chassis, as shown in Figure 1-1.

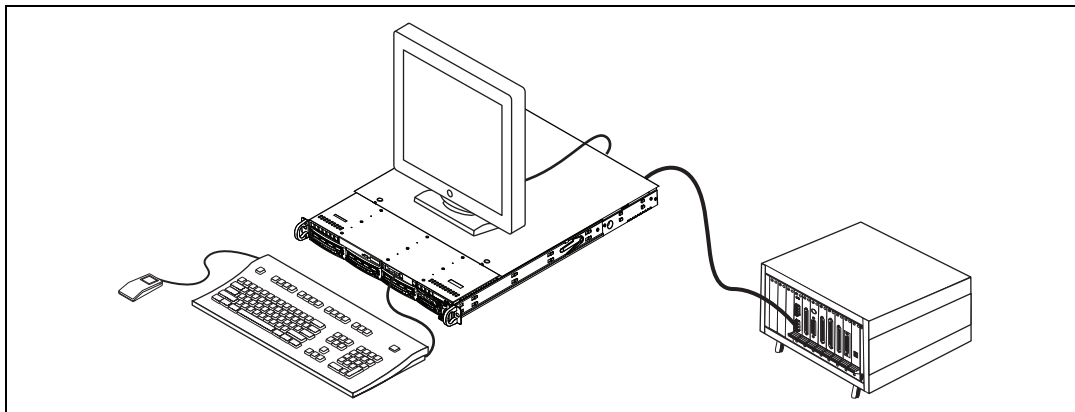

Figure 1-1. Basic MXI-Express x16 Configuration

Larger MXI-Express x16 Systems

You can control more than one PXI Express chassis with a single PC by using the NI PXIe-8389 in a daisy-chain topology.

The NI PXIe-8389 has two ports on its front panel: an upstream port (for connecting towards the host) and a downstream port (which allows for daisy chaining). In the daisy-chain configuration, as a single PCI Express x16 slot is used in the host PC, the data throughput per device is shared between all PXI chassis. Figure 1-2 shows an example of a daisy chain configuration.

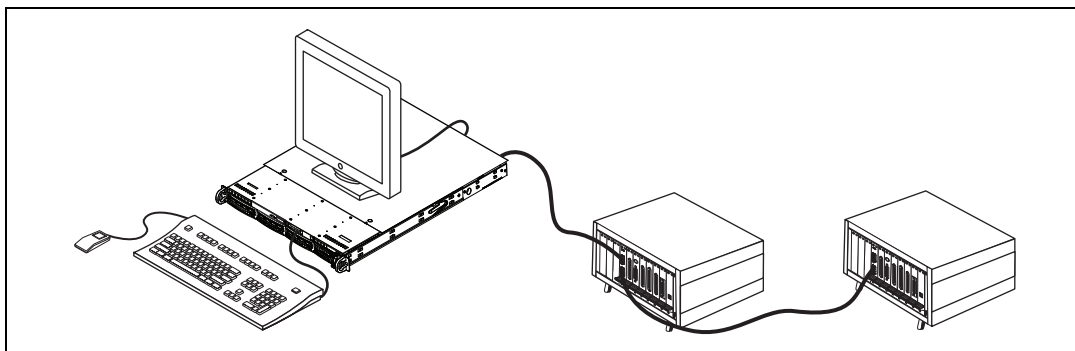

Figure 1-2. Daisy Chain Configuration

What You Need to Get Started

To set up and use your MXI-Express x16 boards, you need the following:

- One NI PCIe-8388 and one or more NI PXIe-8388/9 modules.
- One or more MXI-Express x16 cables.
- A supported host PC (such as an NI RMC-83xx) with an available x16 PCI Express slot.



Note For proper functionality, the host PC must have a certain quality and type of PCI Express clock. Therefore, NI validates and supports only certain hosts. Refer to KnowledgeBase 5J9C7371 for a list of currently supported host platforms.

- An expansion chassis—the PXI Express or CompactPCI Express chassis to control with MXI-Express x16.



Note Your NI PXIe-8388/9 module works in any standard CompactPCI Express chassis adhering to the *PICMG CompactPCI Express EXP.0 R1.0 Specification*, or in a PXI Express chassis compatible with the *PXI Express Hardware Specification*, Revision 1.0 or later.

Unpacking

Your MXI-Express x16 boards are shipped in antistatic packages to prevent electrostatic damage (ESD) to the devices. ESD can damage several components on the device.



Caution Never touch the exposed pins of connectors. Doing so may damage the device.

To avoid such damage in handling the device, take the following precautions:

- Ground yourself using a grounding strap or by holding a grounded object.
- Touch the antistatic package to a metal part of the computer chassis before removing the device from the package.

Remove the device from the package and inspect the device for loose components or any sign of damage. Notify NI if the device appears damaged in any way. Do not install a damaged device into the computer or into a PXI Express or CompactPCI Express chassis.

Store the device in the antistatic envelope when not in use.

Hardware Installation

This chapter explains how to install the MXI-Express x16 hardware.

Hardware Installation

The following are general instructions for installing the MXI-Express x16 boards. Consult your computer user manual or technical reference manual for specific instructions and warnings.



Note The PXI Platform Services software on the *PXI Platform Services* CD or driver CD included with your PXI Express MXI-Express x16 hardware is required to provide chassis and controller identification for PXI features such as trigger routing and slot detection. The PXI Platform Services software also is included with the NI-DAQmx and NI-VISA drivers. For more information, refer to KnowledgeBase 3TJDOND8 at ni.com.

Installing an NI PCIe-8388

Complete the following steps to install the NI PCIe-8388 in your computer.

1. Power off the computer and remove the cover to have access to the PCI Express expansion slots.
2. Touch the metal part of the power supply case inside the computer to discharge any static electricity that might be on your clothes or body. Adhere to proper ESD precautions described in the *Unpacking* section of Chapter 1, *Introduction*.
3. Unplug the computer.



Caution To protect both yourself and the computer from electrical hazards, your computer should remain off until you finish installing the NI PCIe-8388.

4. Select any available PCI Express expansion slot (x16). The slot must be x16 both physically and electrically.



Note Using a PCI Express slot narrower than x16 is not validated or supported. Some x16 slots are wired only as x8 or x4. These slots are not supported.



Note The NI PCIe-8388 requires a host computer that supplies a PCI Express clock that adheres to the *PCI Express Specification*. The NI PCIe-8388 may not be compatible with systems with noncompliant clocks, and requires the clock to exceed certain specifications. Therefore, only certain host PCs are supported for use with the NI PCIe-8388. Refer to KnowledgeBase 5J9C7371 for more information about supported host PCs.

5. Locate the metal PCI Express filler panel that covers the cut-out in the back panel of the computer for the slot you have selected. Open the bracket retention latch or remove and save the bracket-retaining screw (if applicable) and the PCI Express slot filler panel.
6. Align the NI PCIe-8388 with the slot on the back panel. Slowly slide the NI PCIe-8388 until its board-edge connector is touching the expansion slot receptacle. Using slow, evenly distributed pressure, press the NI PCIe-8388 until it seats in the expansion slot.
7. Close the PCI Express board retention latch or reinstall the retaining screw (if applicable) to secure the NI PCIe-8388 to the back panel rail.
8. Replace the computer cover.

Installing an NI PXIe-8388/9

Complete the following steps to install the NI PXIe-8388/9 in your PXI Express or CompactPCI Express chassis.



Note The NI PXIe-8388/9 must be installed in the controller slot (slot 1 in PXI Express).

1. Touch a metal part of the chassis to discharge any static electricity that might be on your clothes or body.
2. Power off your PXI Express or CompactPCI Express chassis and unplug the power cord.



Caution To protect both yourself and the chassis from electrical hazards, leave the chassis off until you finish installing the NI PXIe-8388/9.

3. Remove or open any doors or covers blocking access to the slot where you intend to install the NI PXIe-8388/9.
4. Make sure the injector/ejector handle is in its downward position. Be sure to remove all connector packaging and protective caps from retaining screws on the module. Align the NI PXIe-8388/9 with the board guides on the top and bottom of the system controller slot.



Caution Do not raise the injector/ejector handle as you insert the NI PXIe-8388/9. It will not insert properly unless the handle is in its downward position so that it does not interfere with the injector/ejector rail on the chassis, as shown in Figure 2-1.

5. Hold the handle as you slowly slide the module into the chassis until the handle catches on the injector/ejector rail.
6. Raise the injector/ejector handle until the module firmly seats into the backplane receptacle connectors. The NI PXIe-8388/9 front panel should be even with the chassis front panel.
7. Tighten the bracket-retaining screws on the top and bottom of the front panel to secure the NI PXIe-8388/9 to the chassis.
8. Replace or close any doors or covers to the chassis.

Figure 2-1 shows an NI PXIe-8388/9 just before installation in the system controller slot of a National Instruments PXI Express chassis.

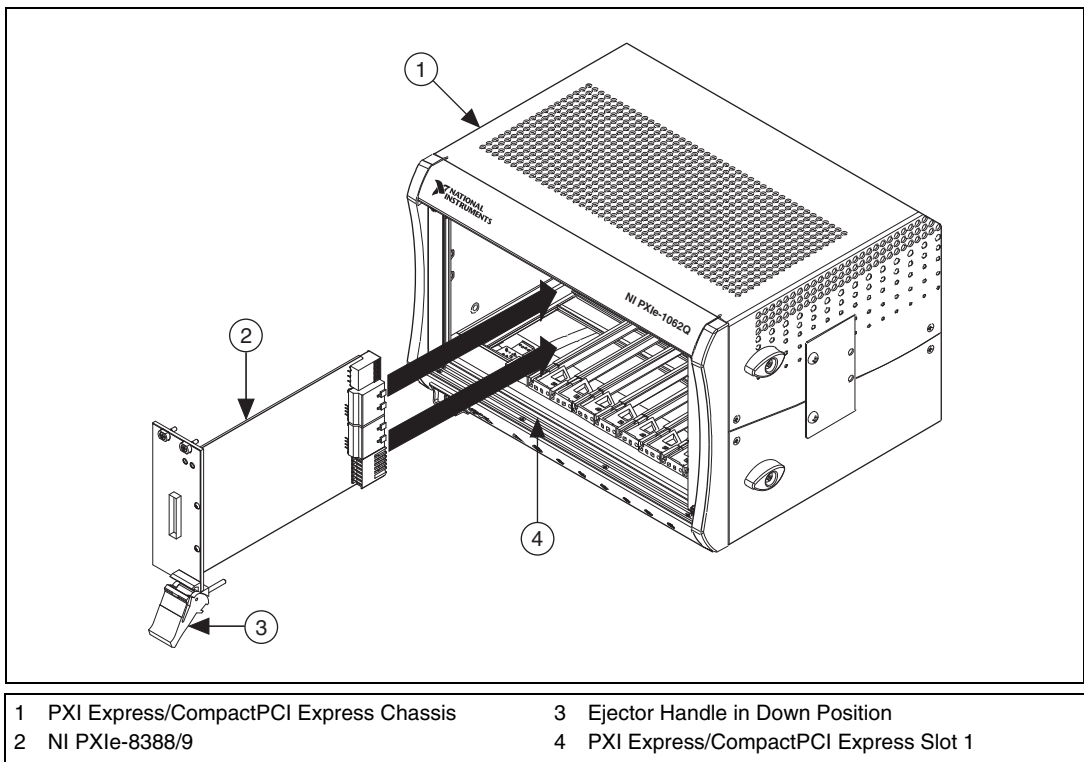

Figure 2-1. NI PXIe-8388/9 Board Before Installation

Cabling



Caution Never touch the exposed pins of connectors. Doing so may damage the device.

Connect the MXI-Express x16 cable to the NI PCIe-8388 and to port 1 of the NI PXIe-8388/9. The cables have no polarity, so either end may be connected to either board.



Caution Do not remove the cable after the system is powered on. Doing so can hang or cause errors in applications communicating with devices behind MXI-Express x16. If a cable becomes unplugged, plug it back into the system. (You may need to restart your computer.)

For more information about cables, refer to the [Cable Options](#) section of Chapter 3, [Hardware Overview](#).

Using the Daisy Chain Topology

You can use the daisy chain topology to create systems with up to four PXI chassis interfaced to the same host PC. Larger systems are not supported.

If daisy chaining additional chassis, connect port 2 of the NI PXIe-8389 to port 1 of the NI PXIe-8388/9 of the daisy chained chassis.



Notes NI MXI-Express x16 supports wake functionality when used in any NI PXI Express chassis or any chassis supporting 5 V_{aux} power. Pressing the power button on any chassis in the chain should power on all chassis in the chain and the host PC, provided the host PC supports PCI Express wake.

When using chassis with no 5 V_{aux} power, the PXI Express or CompactPCI Express chassis must be powered on prior to powering on the host PC. There are no requirements on how MXI-Express x16 expansion chassis are powered on relative to each other, as long as they are all on before the computer is powered on.

Powering On the MXI-Express x16 System

Follow these steps to power on the MXI-Express x16 system.

1. Power on all expansion chassis in any order you choose.
2. Power on the host.

Standard PCI-PCI bridges and switches are used to add PCI devices to a PCI hierarchy in which all the bridges and devices are contained within a single chassis. Because of this, BIOSes and operating systems make the assumption that all PCI devices in the entire hierarchy are available as soon as code execution begins at power on. This assumption means that all expansion chassis must be powered on before the host PC for the BIOS and OS to correctly configure a MXI-Express x16 system.



Note There are no requirements on how MXI-Express x16 expansion chassis are powered on relative to each other, as long as they are all on before the computer is powered on.

Powering Off the MXI-Express x16 System

Because operating systems and drivers commonly make the assumption that PCI devices are present in the system from power on to power off, it is important not to power off the expansion chassis until after the host PC is powered off. Powering off the expansion chassis while the host still is on can cause crashes or hangs.

After the host computer has powered off, the order in which expansion chassis are powered off relative to each other is not important. However, to power off a chassis that still has its upstream link active, you must press the power button for at least 4 seconds.

Hardware Overview

This chapter presents an overview of MXI-Express x16 hardware functionality and explains the operation of each functional unit.

Functional Overview

MXI-Express x16 is based on PCI Express technology.

A MXI-Express x16 kit uses PCI Express switches to enable control of a PXI Express or CompactPCI Express chassis from a PC with an available PCI Express slot. The PCI Express switch architecture is transparent to device drivers, so no additional software is needed to support using PXI Express and CompactPCI Express devices in a chassis connected using MXI-Express x16.



Note The PXI Platform Services software on the *PXI Platform Services* CD or driver CD included with your PXI Express MXI-Express x16 hardware is required to provide chassis and controller identification for PXI features such as trigger routing and slot detection. The PXI Platform Services software also is included with the NI-DAQmx and NI-VISA drivers. For more information, refer to KnowledgeBase 3TJDOND8 at ni.com.

The link between the PC and the chassis is a x16 PCI Express link. This link is a dual-simplex communication channel comprised of low-voltage, differentially driven signal pairs. The link can transmit at a rate of 8 Gbytes/s in each direction simultaneously, though protocol overhead and other inefficiencies reduce the achievable throughput.

Figure 3-1 shows the basic architecture of MXI-Express x16. The NI PCIe-8388 consists of a PCI Express x16 board edge connector, PCI Express repeaters, and one cabled MXI-Express x16 connector. The NI PXIe-8388/9 consists of one or two cabled MXI-Express x16 connectors, a PCI Express switch, and PXI Express connectors.

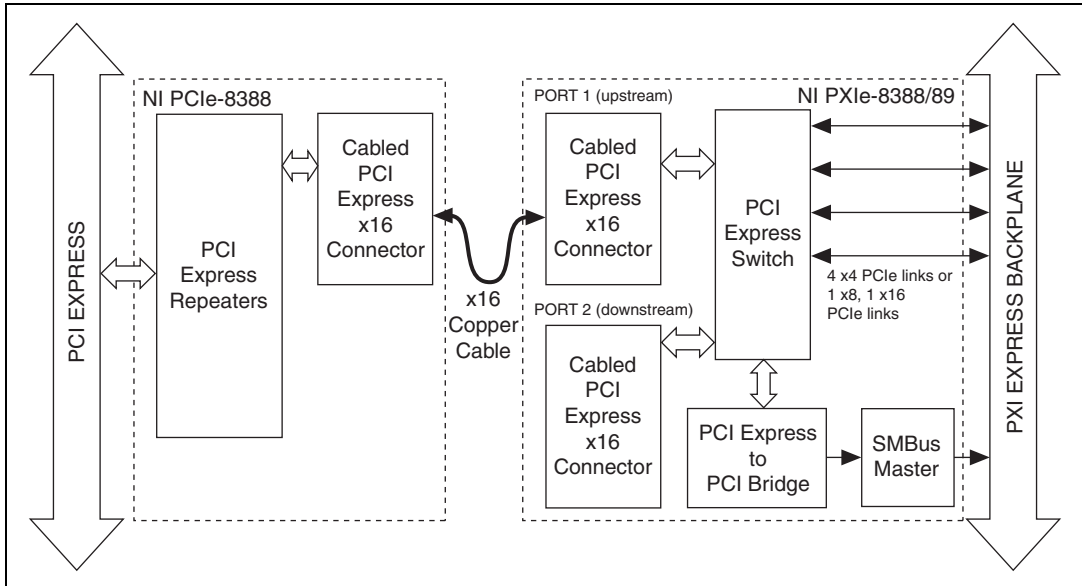

Figure 3-1. MXI-Express x16 Block Diagram

Functional Unit Descriptions

PCI Express x16 Board Edge Connector

You can use the board edge connector to use the NI PCIe-8388 in a x16 PCI Express slot in a PC. The *PCI Express Card Electromechanical Specification* defines this connector.

PCI Express Switch

The *PCI Express Base Specification* defines a PCI Express switch as a logical collection of PCI Express-to-PCI Express bridge devices. NI PCIe-8388 does not contain a PCI Express switch. It uses PCI Express repeaters to drive the PCI Express signals over the PCI Express cable. The PCI Express switch is on the NI PXIe-8388/9 board.

On the NI PXIe-8388/9, the switch upstream port is connected to the cable PORT 1. One downstream port is connected to the SMBus Master, one x16 port is connected to PORT 2 (NI PCIe-8389 only), and four x4 ports or one x8 and one x16 port are connected to the backplane, depending on the chassis backplane configuration.

Cabled MXI-Express x16 Connector

The cabled MXI-Express x16 connector provides the transmit and receive signals to connect an NI PCIe-8388 and an NI PXIe-8388/9, plus some miscellaneous signals such as a clock and reset.

PCI Express-to-PCI Bridge

The *PCI Express Base Specification* defines a PCI Express-to-PCI bridge as a device that connects a PCI Express fabric and a PCI hierarchy. On the NI PXIe-8388/9, the PCI Express-to-PCI bridge connects the PCI Express switch and an SMBus Master on the board.

SMBus Master

The SMBus is a low-speed bus for reading and configuring devices outside the normal PCI Express mechanism. The PXI Express specification requires controllers to supply an SMBus for reading chassis configuration information from an EPROM. You also can use it for fan control, power monitors, or other system devices. In addition, devices on plug-in boards may connect to the SMBus for purposes specific to those devices.

LED Indicators

The LEDs on MXI-Express x16 cards give status information about power supplies and link state. The NI PXIe-8388 has one tri-color LED for the port on the panel. The NI PXIe-8389 has two tri-color LEDs, one for each port.

Table 3-1 describes the NI PXIe-8388/9 front-panel LEDs.

Table 3-1. NI PXIe-8388/9 Status LED Messages

LED	Meaning
Off	Power is off
Red, blinking	Power is out of spec
Amber	Power is within spec; link not established
Green	Power is within spec; link established

The NI PXIe-8388/9 has additional LEDs on the back of the board near the front panel connector. These LEDs give additional information about the link status of the PCI Express lanes on the module to the backplane.

Cable Options

MXI-Express x16 is available with cables of various lengths. Table 3-2 shows the cables available from National Instruments.

Table 3-2. National Instruments MXI-Express x16 Cables

Cable Length (Meters)	Description
1 m	MXI-Express x16 cable (part number 781763-01)
3 m	MXI-Express x16 cable (part number 781763-03)

Specifications

This appendix lists the system specifications for NI PCIe-8388 and NI PXIe-8388/9 cards. These specifications are typical at 25 °C, unless otherwise stated.



Note Specifications are subject to change without notice.

Physical

Dimensions

NI PXIe-8388.....	10.0 × 16.0 cm (3.9 × 6.3 in.)
NI PXIe-8389.....	10.0 × 16.0 cm (3.9 × 6.3 in.)
NI PCIe-8388.....	6.9 × 15.4 cm (2.72 × 6.06 in.)

Maximum cable length..... 3 m

Slot requirements

NI PXIe-8388/9.....	One system slot, plus one or two controller expansion slots (PXI Express or CompactPCI Express)
NI PCIe-8388.....	One PCI Express x16 slot (approved hosts only)



Note The NI PCIe-8388 requires a host computer that supplies a PCI Express clock that adheres to the *PCI Express Specification*. The NI PCIe-8388 may not be compatible with systems with noncompliant clocks, particularly systems with clocks whose frequency peaks over 100 MHz. Refer to KnowledgeBase 5J9C7371 on ni.com for host compatibility information.

Compatibility

- NI PXIe-8388/9Fully compatible with the *PXI Express Hardware Specification, Revision 1.0* and the *PICMG CompactPCI Express EXP.0 R1.0 Specification*
- NI PCIe-8388.....Fully compatible with the *PCI Express Specification, Revision 2.0*

Weight

- NI PXIe-83889.2 oz (261 g)
- NI PXIe-838914.2 oz (403 g)
- NI PCIe-8388.....3.4 oz (96 g)

Power Requirements

NI PXIe-8388/9

Power Rail	Typical Current	Maximum Current
+3.3 V	1.54 A	5.25 A
+5 V	0 A	0 A
+12 V	0.55 A	2.0 A
+5 V _{aux}	0.6 A	0.85 A

Environment

NI PXIe-8388/9

Pollution Degree2

Maximum altitude.....2,000 m

Indoor use only.

Operating Environment

Ambient temperature range.....	0 to 55 °C (Tested in accordance with IEC-60068-2-1 and IEC-60068-2-2. Meets MIL-PRF-28800F Class 3 low temperature limit and MIL-PRF-28800F Class 2 high temperature limit.)
Relative humidity range	10 to 90%, noncondensing (Tested in accordance with IEC-60068-2-56.)

Storage Environment

Ambient temperature range.....	– 40 to 71 °C (Tested in accordance with IEC-60068-2-1 and IEC-60068-2-2. Meets MIL-PRF-28800F Class 3 limits.)
Relative humidity range	5 to 95%, noncondensing (Tested in accordance with IEC-60068-2-56.)

Shock and Vibration

Operational shock	30 g peak, half-sine, 11 ms pulse (Tested in accordance with IEC-60068-2-27. Meets MIL-PRF-28800F Class 2 limits.)
-------------------------	---

Random Vibration

Operating.....	5 to 500 Hz, 0.3 g _{rms}
Nonoperating.....	5 to 500 Hz, 2.4 g _{rms} (Tested in accordance with IEC-60068-2-64. Nonoperating test profile exceeds the requirements of MIL-PRF-28800F, Class 3.)

NI PCIe-8388

Pollution Degree2

Maximum altitude.....2,000 m

Indoor use only.

Operating Environment

Ambient temperature range0 to 55 °C
(Tested in accordance with IEC-60068-2-1 and IEC-60068-2-2.)

Relative humidity range.....10 to 90%, noncondensing
(Tested in accordance with IEC-60068-2-56.)

Storage Environment

Ambient temperature range-20 to 70 °C
(Tested in accordance with IEC-60068-2-1 and IEC-60068-2-2.)

Relative humidity range.....5 to 95%, noncondensing
(Tested in accordance with IEC-60068-2-56.)



Caution Clean the NI PXIe-8388/9 and NI PCIe-8388 with a soft nonmetallic brush. Make sure that the device is completely dry and free from contaminants before returning it to service.

Safety

This product is designed to meet the requirements of the following standards of safety for electrical equipment for measurement, control, and laboratory use:

- IEC 61010-1, EN 61010-1
- UL 61010-1, CSA 61010-1



Note For UL and other safety certifications, refer to the product label or the [Online Product Certification](#) section.

Electromagnetic Compatibility

This product is designed to meet the requirements of the following standards of EMC for electrical equipment for measurement, control, and laboratory use:

- EN 61326 (IEC 61326): Class A emissions; Basic immunity
- EN 55011 (CISPR 11): Group 1, Class A emissions
- AS/NZS CISPR 11: Group 1, Class A emissions
- FCC 47 CFR Part 15B: Class A emissions
- ICES-001: Class A emissions



Note For the standards applied to assess the EMC of this product, refer to the *Online Product Certification* section.

CE Compliance (CE)

This product meets the essential requirements of applicable European Directives as follows:

- 2006/95/EC; Low-Voltage Directive (safety)
- 2004/108/EC; Electromagnetic Compatibility Directive (EMC)

Online Product Certification

Refer to the product Declaration of Conformity (DoC) for additional regulatory compliance information. To obtain product certifications and the DoC for this product, visit ni.com/certification, search by model number or product line, and click the appropriate link in the Certification column.

Environmental Management

NI is committed to designing and manufacturing products in an environmentally responsible manner. NI recognizes that eliminating certain hazardous substances from our products is beneficial to the environment and to NI customers.

For additional environmental information, refer to the *NI and the Environment* Web page at ni.com/environment. This page contains the environmental regulations and directives with which NI complies, as well as other environmental information not included in this document.

Waste Electrical and Electronic Equipment (WEEE)



EU Customers At the end of the product life cycle, all products *must* be sent to a WEEE recycling center. For more information about WEEE recycling centers, National Instruments WEEE initiatives, and compliance with WEEE Directive 2002/96/EC on Waste and Electronic Equipment, visit ni.com/environment/weee.

电子信息产品污染控制管理办法（中国 RoHS）



中国客户 National Instruments 符合中国电子信息产品中限制使用某些有害物质指令 (RoHS)。关于 National Instruments 中国 RoHS 合规性信息，请登录 ni.com/environment/rohs_china。(For information about China RoHS compliance, go to ni.com/environment/rohs_china.)

Technical Support and Professional Services

Visit the following sections of the award-winning National Instruments Web site at ni.com for technical support and professional services:

- **Support**—Technical support at ni.com/support includes the following resources:
 - **Self-Help Technical Resources**—For answers and solutions, visit ni.com/support for software drivers and updates, a searchable KnowledgeBase, product manuals, step-by-step troubleshooting wizards, thousands of example programs, tutorials, application notes, instrument drivers, and so on. Registered users also receive access to the NI Discussion Forums at ni.com/forums. NI Applications Engineers make sure every question submitted online receives an answer.
 - **Standard Service Program Membership**—This program entitles members to direct access to NI Applications Engineers via phone and email for one-to-one technical support as well as exclusive access to on demand training modules via the Services Resource Center. NI offers complementary membership for a full year after purchase, after which you may renew to continue your benefits.

For information about other technical support options in your area, visit ni.com/services, or contact your local office at ni.com/contact.

- **Training and Certification**—Visit ni.com/training for self-paced training, eLearning virtual classrooms, interactive CDs, and Certification program information. You also can register for instructor-led, hands-on courses at locations around the world.
- **System Integration**—If you have time constraints, limited in-house technical resources, or other project challenges, National Instruments Alliance Partner members can help. To learn more, call your local NI office or visit ni.com/alliance.

You also can visit the Worldwide Offices section of ni.com/niglobal to access the branch office Web sites, which provide up-to-date contact information, support phone numbers, email addresses, and current events.

Index

B

block diagram (figure), 3-2
board edge connector, 3-2

C

cable options (table), 3-4
cabled MXI-Express x16 connector, 3-3
CE compliance specifications, A-5
configuration
 additional topologies (figure), 1-2
 basic (figure), 1-2
conventions used in the manual, *vii*

D

daisy chain topology, 2-4
diagnostic tools (NI resources), B-1
documentation
 conventions used in manual, *vii*
 NI resources, B-1
 related documentation, *viii*
drivers (NI resources), B-1

E

electromagnetic compatibility
 specifications, A-5
environmental management
 specifications, A-5
 waste electrical and electronic equipment
 (WEEE) information, A-6
environmental specifications, A-2
 NI PCIe-8388, A-4
 NI PXIe-8388/9, A-2
examples (NI resources), B-1

F

functional unit descriptions, 3-2

G

getting started, 1-3

H

help, technical support, B-1

I

installation
 cabling, 2-4
 daisy chain topology, 2-4
 hardware, 2-1
 of an NI PCIe-8388, 2-1
 of an NI PXIe-8388/9, 2-2
 powering off the MXI-Express x16
 system, 2-5
 powering on the MXI-Express x16
 system, 2-5
instrument drivers (NI resources), B-1

K

KnowledgeBase, B-1

L

larger MXI-Express x16 systems, 1-2
LED indicators, 3-3

M

- MXI-Express x16
 - basic configuration (figure), 1-2
 - basic system, 1-2
 - block diagram (figure), 3-2
 - cable options (table), 3-4
 - daisy chain configuration (figure), 1-2
 - hardware overview, 3-1
 - larger systems, 1-2
 - specifications, A-1
 - system
 - description, 1-1
 - getting started, 1-3

N

- National Instruments support and services, B-1
- NI PCIe-8388, installation, 2-1
- NI PXIe-8388/9
 - installation, 2-2
 - figure, 2-3

O

- online product certification specifications, A-5
- operating environment specifications
 - NI PCIe-8388, A-4
 - NI PXIe-8388/9, A-3
- overview
 - functional, 3-1
 - functional unit descriptions, 3-2
 - hardware, 3-1

P

- PCI Express
 - bridge to PCI, 3-3
 - switch, 3-2
 - x16 board edge connector, 3-2

- physical specifications, A-1
- power requirement specifications, A-2
- programming examples (NI resources), B-1

R

- random vibration specifications
 - NI PXIe-8388/9, A-3
- recycling hardware, A-6
- related documentation, *viii*

S

- safety specifications, A-4
- shock and vibration specifications
 - NI PXIe-8388/9, A-3
- SMBus Master, 3-3
- software (NI resources), B-1
- specifications, A-1
 - CE compliance, A-5
 - electromagnetic compatibility, A-5
 - environmental, A-2
 - NI PCIe-8388, A-4
 - NI PXIe-8388/9, A-2
 - environmental management, A-5
 - waste electrical and electronic equipment (WEEE) information, A-6
- online product certification, A-5
- operating environment
 - NI PCIe-8388, A-4
 - NI PXIe-8388/9, A-3
- physical, A-1, A-2
- power requirements, A-2
- random vibration, NI PXIe-8388/9, A-3
- safety, A-4
- shock and vibration, NI PXIe-8388/9, A-3
- storage environment
 - NI PCIe-8388, A-4
 - NI PXIe-8388/9, A-3
- status LED messages (table), 3-3

storage environment specifications

NI PCIe-8388, A-4

NI PXIe-8388/9, A-3

support, technical, B-1

switch, PCI Express, 3-2

T

technical support, B-1

training and certification (NI resources), B-1

troubleshooting (NI resources), B-1

U

unpacking, 1-3

W

waste electrical and electronic equipment
(WEEE) information, A-6

Web resources, B-1