

COMPREHENSIVE SERVICES

We offer competitive repair and calibration services, as well as easily accessible documentation and free downloadable resources.

SELL YOUR SURPLUS

We buy new, used, decommissioned, and surplus parts from every NI series. We work out the best solution to suit your individual needs.

 Sell For Cash  Get Credit  Receive a Trade-In Deal

OBSOLETE NI HARDWARE IN STOCK & READY TO SHIP

We stock **New**, **New Surplus**, **Refurbished**, and **Reconditioned** NI Hardware.



Bridging the gap between the manufacturer and your legacy test system.

 1-800-915-6216

 www.apexwaves.com

 sales@apexwaves.com

All trademarks, brands, and brand names are the property of their respective owners.

Request a Quote

 **CLICK HERE**

REM-11100

DATASHEET

NI REM-11100

Voltage Input Module for Remote I/O



- Four input ranges to choose from (0 V to 10V, $\pm 10V$, 0 V to 5 V, and $\pm 5V$)
- Built-in power supply for sensors
- Simultaneous sampling
- Spring-terminal connectors allow fast wiring without tools
- Communication to the higher-level system via EtherCAT
- $-25\text{ }^{\circ}\text{C}$ to $60\text{ }^{\circ}\text{C}$ temperature range to meet a variety of application and environmental needs

Remote I/O Overview

Remote I/O is a low-cost, modular system for simple machine control and measurements. A Remote I/O system consists of an EtherCAT bus coupler and individual modules mounted on a DIN rail and is controlled from a Real-Time controller such as a CompactRIO Controller or Industrial Controller.

- Round out your system with low-cost I/O for simple tasks while your controller handles advanced tasks such as image processing and high-speed or specialty measurements.
- Add only the I/O you need where you need it with the modular, distributed system.
- Connect multiple Remote I/O systems and EtherCAT chassis to meet your I/O needs.

Figure 1. NI Remote I/O System



NI Embedded Control and Monitoring Suite

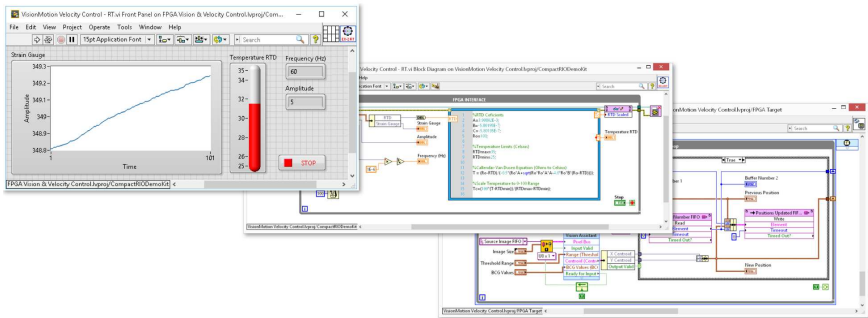

- Use a single toolchain for every phase of your design cycle – from modeling and simulation, to prototyping and validation, to deployment and beyond.
- NI ECM Suite combines LabVIEW Professional Development System with add-on software for programming Real-Time, FPGA, SoftMotion and Vision Acquisition devices.
- Combine LabVIEW with your expertise to efficiently design a system by integrating graphical, C code, .m files, and state-based simulations in one environment.
- Reduce development time with built-in constructs to manage low-level tasks such as timing and memory in an intuitive programming environment.
- Accelerate your development with over 950 available signal processing, analysis, control, and mathematics functions.
- Get to solutions faster with extensive support and training that scale with the complexity of your systems.

REM-11100 Output Circuitry

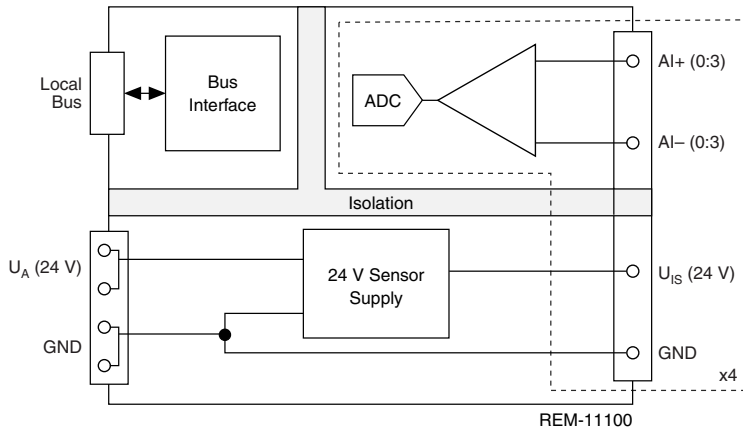

REM-11100 Specifications

The following specifications are typical for the range -25 °C to 60 °C unless otherwise noted.

Input Characteristics

Number of inputs	4
Input signal	0 V to 5 V, -5 V to 5 V, 0 V to 10 V, -10 V to 10 V
Resolution A/D	16-bit
Conversion time A/D	31.25 μs
Limit frequency (3 dB)	30 Hz , 12 kHz
Measured value representation	16 bits (15 bits + sign bit)
Process data update	160 μs
Input filter ¹	30 Hz, 12 kHz and mean-value generation
Precision ²	0.1%
Transient protection of inputs	Suppressor diode
Input resistance	268 kΩ, typical

¹ Value generation can be parameterized.

² Percent of measuring range final value for active mean-value generation and 30 Hz filter.

Common mode voltage range signal - ground	-50 VDC to 50 VDC
Overload protection	±30 VDC, maximum

Input Scaling

Hex	Dec	0 V to 10 V	±10 V	0 V to 5 V	±5 V
8001	Overrange	>10.837 V	>10.837 V	>5.419 V	>5.419 V
7F00	32512	10.837 V	10.837 V	5.419 V	5.419 V
7530	30000	10 V	10 V	5 V	5 V
1	1	333.33 μV	333.33 μV	166.67 μV	166.67 μV
0	0	≤0 V	0 V	≤0 V	0 V
FFFF	-1	—	-333.33 μV	—	-166.67 μV
8AD0	-30000	—	-10 V	—	-5 V
8100	-32512	—	-10.837 V	—	-5.419 V
8080	Underrange	—	<-10.837 V	—	<-5.419 V

Power Requirements

Communications power from U_{Bus}	5 VDC, via bus connector
Current consumption from U_{Bus}	120 mA, typical; 150 mA, maximum
Total power consumption from U_{Bus} and U_A	
Typical	1.5 W
Maximum	1.83 W

I/O Supply

Supply of analog output modules U_A	24 VDC (I/O supply and sensor supply)
Maximum permissible voltage range	19.2 VDC to 30 VDC (including all tolerances, including ripple)
Current consumption from U_A	
$I_{IS} = 0$ mA	38 mA, typical 45 mA, maximum
$I_{IS} = 4 \times 20$ mA (nominal load)	118 mA, typical 125 mA, maximum
$I_{IS} = 4 \times 50$ mA (full load)	238 mA, typical 245 mA, maximum
Surge protection	Electronic (35 V, 0.5 s)
Polarity reversal protection	Polarity protection diode
Protection	Suppressor diode
Input Supply (U_{IS})	
Supply Voltage	24 VDC (from U_A)
Current consumption	50 mA, maximum per channel
Short-circuit protection	PTC resistor
External fuse rating	8 A



Caution Connect an external fuse to the 24 V U_A supply to protect against polarity reversal. The power supply must provide four times the nominal current of the external fuse. This rating ensures that the fuse trips in the event of an error.

Remote I/O Local Bus

Connection method	Bus connector
Transmission speed	100 MBit/s

Physical Characteristics



Note For more information about connecting your device, refer to the device getting started guide on ni.com/manuals

Spring-terminal wiring

Gauge	0.2 mm ² to 1.5 mm ² (24 AWG to 16 AWG), solid or stranded
Wire strip length	8.0 mm (0.31 in.) of insulation stripped from the end
Wires per connection	One wire per spring terminal
Dimensions ³	126.1 mm (4.96 in.) × 35.0 mm (1.38 in.) × 54.0 mm (2.13 in.)
Weight ⁴	145 g (5.11 oz)



Note For dimensional drawings of the REM-11100, visit ni.com/dimensions and search by module number.

Isolation Withstand Voltages

Test section	Test voltage
5 V communications power (logic), 24 V supply (I/O)	500 VAC, 50 Hz, 1 min.
5 V supply (logic) / analog inputs	500 VAC, 50 Hz, 1 min.
5 V supply (logic) / functional earth ground	500 VAC, 50 Hz, 1 min.
24 V supply (I/O) / analog inputs	500 VAC, 50 Hz, 1 min.
24 V supply (I/O) / functional earth ground	500 VAC, 50 Hz, 1 min.
Analog inputs / functional earth ground	500 VAC, 50 Hz, 1 min.

Electromagnetic Compatibility

This product meets the requirements of the following EMC standards for electrical equipment.

- EN 61000-4-2 (IEC 61000-4-2): Electrostatic discharge (ESD); Criterion B; 6 kV contact discharge, 8 kV air discharge
- EN 61000-4-3 (IEC 61000-4-3): Electromagnetic fields; Criterion A; Field intensity: 10 V/m
- EN 61000-4-4 (IEC 61000-4-4): Fast transients (burst); Criterion B, 2 kV

³ The depth is valid when a TH 35-7.5 DIN rail is used (according to EN 60715).

⁴ With connectors and bus connector.

- EN 61000-4-5 (IEC 61000-4-5): Transient surge voltage (surge); Criterion B; DC supply lines: ± 0.5 kV/ ± 0.5 kV (symmetrical/asymmetrical); ± 1 kV to shielded I/O cables
- EN 61000-4-6 (IEC 61000-4-6): Conducted interference; Criterion A; Test voltage 10 V
- EN 61000-6-2: Noise immunity
- EN 61000-6-3: Noise emission
- EN 55022: Radio interference properties; Class B

CE Compliance

This product meets the essential requirements of applicable European Directives, as follows:

- 2014/30/EU; Electromagnetic Compatibility Directive (EMC)

Shock and Vibration

Vibration resistance (EN/IEC 60068-2-6)	5 g
Shock (EN/IEC 60068-2-27)	30 g
Continuous shock (EN/IEC 60068-2-27)	10 g

Environmental

Operating temperature	-25 °C to 60 °C
Storage temperature	-40 °C to 85 °C
Ingress protection	IP20
Protection class	III, EN/IEC 61140, VDE 0140-1
Operating humidity	5% to 95%, non-condensing
Storage humidity	5% to 95%, non-condensing
Maximum altitude	3,000 m
Air pressure	70 kPa to 106 kPa

Indoor use only.

Tolerance Data

The following specifications apply for tolerances at $T_A = 25$ °C.

- Valid for nominal operation ($U_A = 24$ V in the default configuration (unless documented otherwise).
- Default configuration: Filter with 30 Hz, 16-sample mean-value.
- Typical data contains offset error, gain error, and linearity error in the respective default setting.
- All tolerances indicated as a percentage are related to the positive measuring range final value.

- Please also observe the values for temperature drift and the tolerances under influences of electromagnetic interferences.
- Additional tolerances may occur due to the influence of high-frequency electromagnetic interference caused by wireless transmission systems in the near vicinity. The values specified refer to nominal operation in the event of direct interference to components without additional shielding such as a steel cabinet.
- Tolerances can be reduced by providing further shielding measures for the I/O module such as a shielded control box/control cabinet.

160 μ s update time (12 kHz filter, without mean-value generation)

Measuring range	0 V to 5 V, ± 5 V 0 V to 10 V, ± 10 V
Absolute	± 50 mV, typical ± 80 mV, maximum
Relative	$\pm 0.5\%$, typical $\pm 0.8\%$, maximum

160 μ s update time, default (30 Hz filter, 16-sample average value)

Measuring range	0 V to 5 V, ± 5 V 0 V to 10 V, ± 10 V
Absolute	± 10 mV, typical ± 30 mV, maximum
Relative	$\pm 0.10\%$, typical $\pm 0.30\%$, maximum

The following specifications apply for tolerance and temperature response at $T_A = -25$ °C to $+60$ °C.

Measuring range	0 V to 5 V, ± 5 V 0 V to 10 V, ± 10 V
Drift ⁵	± 100 ppm/K, typical ± 150 ppm/K, maximum

Tolerances influenced by electromagnetic interference

Electromagnetic fields (EN 61000-4-3/IEC 61000-4-3)	$< \pm 0.1\%$
Fast transients (burst) (EN 61000-4-4/IEC 61000-4-4)	$< \pm 0.1\%$
Conducted interference (EN 61000-4-6/IEC 61000-4-6)	$< \pm 0.1\%$

⁵ The drift values refer to the relevant measuring range final value.

Refer to the *NI Trademarks and Logo Guidelines* at ni.com/trademarks for information on NI trademarks. Other product and company names mentioned herein are trademarks or trade names of their respective companies. For patents covering NI products/technology, refer to the appropriate location: **Help»Patents** in your software, the `patents.txt` file on your media, or the *National Instruments Patent Notice* at ni.com/patents. You can find information about end-user license agreements (EULAs) and third-party legal notices in the readme file for your NI product. Refer to the *Export Compliance Information* at ni.com/legal/export-compliance for the NI global trade compliance policy and how to obtain relevant HTS codes, ECCNs, and other import/export data. NI MAKES NO EXPRESS OR IMPLIED WARRANTIES AS TO THE ACCURACY OF THE INFORMATION CONTAINED HEREIN AND SHALL NOT BE LIABLE FOR ANY ERRORS. U.S. Government Customers: The data contained in this manual was developed at private expense and is subject to the applicable limited rights and restricted data rights as set forth in FAR 52.227-14, DFAR 252.227-7014, and DFAR 252.227-7015.

© 2016 National Instruments. All rights reserved.

376557A-02 Oct16