

## COMPREHENSIVE SERVICES

We offer competitive repair and calibration services, as well as easily accessible documentation and free downloadable resources.

## SELL YOUR SURPLUS

We buy new, used, decommissioned, and surplus parts from every NI series. We work out the best solution to suit your individual needs.

 Sell For Cash  Get Credit  Receive a Trade-In Deal

## OBSOLETE NI HARDWARE IN STOCK & READY TO SHIP

We stock **New, New Surplus, Refurbished, and Reconditioned** NI Hardware.



*Bridging the gap between the manufacturer and your legacy test system.*

 1-800-915-6216

 [www.apexwaves.com](http://www.apexwaves.com)

 [sales@apexwaves.com](mailto:sales@apexwaves.com)

*All trademarks, brands, and brand names are the property of their respective owners.*

**Request a Quote**

 **CLICK HERE**

**RMX-4127**

# RMX

## RMX Programmable Power Supplies User Manual

*RMX-4120*

*RMX-4121*

*RMX-4122*

*RMX-4123*

*RMX-4124*

*RMX-4125*

*RMX-4126*

*RMX-4127*

# About the RMX User Manual

This manual is intended for users of the Regulated DC Power Supply and their instructors. It is assumed that the reader has knowledge about electrical safety standards and the electrical aspects of regulated DC power supplies.

## Safety Guidelines



Indicates general danger, warning, or caution. When this symbol is marked on the product, see the relevant section in the operation manual.



Indicates a location whose surface can become hot.



Protective conductor terminal.



Chassis (frame) terminal.



On (supply).



Off (supply).

## Worldwide Technical Support and Product Information

[ni.com](http://ni.com)

## Worldwide Offices

Visit [ni.com/niglobal](http://ni.com/niglobal) to access the branch office Web sites, which provide up-to-date contact information, support phone numbers, email addresses, and current events.

## National Instruments Corporate Headquarters

11500 North Mopac Expressway Austin, Texas 78759-3504 USA Tel: 512 683 0100

For further support information, refer to the [NI Services](#) appendix. To comment on National Instruments documentation, refer to the National Instruments website at [ni.com/info](http://ni.com/info) and enter the Info Code `feedback`.

# Legal Information

---

## Limited Warranty

This document is provided 'as is' and is subject to being changed, without notice, in future editions. For the latest version, refer to [ni.com/manuals](http://ni.com/manuals). NI reviews this document carefully for technical accuracy; however, NI MAKES NO EXPRESS OR IMPLIED WARRANTIES AS TO THE ACCURACY OF THE INFORMATION CONTAINED HEREIN AND SHALL NOT BE LIABLE FOR ANY ERRORS.

NI warrants that its hardware products will be free of defects in materials and workmanship that cause the product to fail to substantially conform to the applicable NI published specifications for one (1) year from the date of invoice.

For a period of ninety (90) days from the date of invoice, NI warrants that (i) its software products will perform substantially in accordance with the applicable documentation provided with the software and (ii) the software media will be free from defects in materials and workmanship.

If NI receives notice of a defect or non-conformance during the applicable warranty period, NI will, in its discretion: (i) repair or replace the affected product, or (ii) refund the fees paid for the affected product. Repaired or replaced Hardware will be warranted for the remainder of the original warranty period or ninety (90) days, whichever is longer. If NI elects to repair or replace the product, NI may use new or refurbished parts or products that are equivalent to new in performance and reliability and are at least functionally equivalent to the original part or product.

You must obtain an RMA number from NI before returning any product to NI. NI reserves the right to charge a fee for examining and testing Hardware not covered by the Limited Warranty.

This Limited Warranty does not apply if the defect of the product resulted from improper or inadequate maintenance, installation, repair, or calibration (performed by a party other than NI); unauthorized modification; improper environment; use of an improper hardware or software key; improper use or operation outside of the specification for the product; improper voltages; accident, abuse, or neglect; or a hazard such as lightning, flood, or other act of nature.

THE REMEDIES SET FORTH ABOVE ARE EXCLUSIVE AND THE CUSTOMER'S SOLE REMEDIES, AND SHALL APPLY EVEN IF SUCH REMEDIES FAIL OF THEIR ESSENTIAL PURPOSE.

EXCEPT AS EXPRESSLY SET FORTH HEREIN, PRODUCTS ARE PROVIDED "AS IS" WITHOUT WARRANTY OF ANY KIND AND NI DISCLAIMS ALL WARRANTIES, EXPRESSED OR IMPLIED, WITH RESPECT TO THE PRODUCTS, INCLUDING ANY IMPLIED WARRANTIES OF MERCHANTABILITY, FITNESS FOR A PARTICULAR PURPOSE, TITLE OR NON-INFRINGEMENT, AND ANY WARRANTIES THAT MAY ARISE FROM USAGE OF TRADE OR COURSE OF DEALING. NI DOES NOT WARRANT, GUARANTEE, OR MAKE ANY REPRESENTATIONS REGARDING THE USE OF OR THE RESULTS OF THE USE OF THE PRODUCTS IN TERMS OF CORRECTNESS, ACCURACY, RELIABILITY, OR OTHERWISE. NI DOES NOT WARRANT THAT THE OPERATION OF THE PRODUCTS WILL BE UNINTERRUPTED OR ERROR FREE.

In the event that you and NI have a separate signed written agreement with warranty terms covering the products, then the warranty terms in the separate agreement shall control.

## Copyright

Under the copyright laws, this publication may not be reproduced or transmitted in any form, electronic or mechanical, including photocopying, recording, storing in an information retrieval system, or translating, in whole or in part, without the prior written consent of National Instruments Corporation.

National Instruments respects the intellectual property of others, and we ask our users to do the same. NI software is protected by copyright and other intellectual property laws. Where NI software may be used to reproduce software or other materials belonging to others, you may use NI software only to reproduce materials that you may reproduce in accordance with the terms of any applicable license or other legal restriction.

## End-User License Agreements and Third-Party Legal Notices

You can find end-user license agreements (EULAs) and third-party legal notices in the following locations:

- Notices are located in the <National Instruments>\\_Legal Information and <National Instruments> directories.
- EULAs are located in the <National Instruments>\Shared\MDF\Legal\license directory.
- Review <National Instruments>\\_Legal Information.txt for information on including legal information in installers built with NI products.

## U.S. Government Restricted Rights

If you are an agency, department, or other entity of the United States Government ("Government"), the use, duplication, reproduction, release, modification, disclosure or transfer of the technical data included in this manual is governed by the Restricted Rights provisions under Federal Acquisition Regulation 52.227-14 for civilian agencies and Defense Federal Acquisition Regulation Supplement Section 252.227-7014 and 252.227-7015 for military agencies.

## Trademarks

Refer to the *NI Trademarks and Logo Guidelines* at [ni.com/trademarks](http://ni.com/trademarks) for more information on National Instruments trademarks.

ARM, Keil, and  $\mu$ Vision are trademarks or registered of ARM Ltd or its subsidiaries.

LEGO, the LEGO logo, WEDO, and MINDSTORMS are trademarks of the LEGO Group.

TETRIX by Pitsco is a trademark of Pitsco, Inc.

FIELD BUS FOUNDATION™ and FOUNDATION™ are trademarks of the Fieldbus Foundation.

EtherCAT® is a registered trademark of and licensed by Beckhoff Automation GmbH.

CANopen® is a registered Community Trademark of CAN in Automation e.V.

DeviceNet™ and EtherNet/IP™ are trademarks of ODVA.

Go!, SensorDAQ, and Vernier are registered trademarks of Vernier Software & Technology. Vernier Software & Technology and [vernier.com](http://vernier.com) are trademarks or trade dress.

Xilinx is the registered trademark of Xilinx, Inc.

Taptite and Trilobular are registered trademarks of Research Engineering & Manufacturing Inc.

FireWire® is the registered trademark of Apple Inc.

Linux® is the registered trademark of Linus Torvalds in the U.S. and other countries.

Handle Graphics®, MATLAB®, Real-Time Workshop®, Simulink®, Stateflow®, and xPC TargetBox® are registered trademarks, and TargetBox™ and Target Language Compiler™ are trademarks of The MathWorks, Inc.

Tektronix®, Tek, and Tektronix, Enabling Technology are registered trademarks of Tektronix, Inc.

The Bluetooth® word mark is a registered trademark owned by the Bluetooth SIG, Inc.

The ExpressCard™ word mark and logos are owned by PCMCIA and any use of such marks by National Instruments is under license.

The mark LabWindows is used under a license from Microsoft Corporation. Windows is a registered trademark of Microsoft Corporation in the United States and other countries.

Other product and company names mentioned herein are trademarks or trade names of their respective companies.

Members of the National Instruments Alliance Partner Program are business entities independent from National Instruments and have no agency, partnership, or joint-venture relationship with National Instruments.

## Patents

For patents covering National Instruments products/technology, refer to the appropriate location: **Help»Patents** in your software, the `patents.txt` file on your media, or the *National Instruments Patent Notice* at [ni.com/patents](http://ni.com/patents).

## Export Compliance Information

Refer to the *Export Compliance Information* at [ni.com/legal/export-compliance](http://ni.com/legal/export-compliance) for the National Instruments global trade compliance policy and how to obtain relevant HTS codes, ECCNs, and other import/export data.

## WARNING REGARDING USE OF NATIONAL INSTRUMENTS PRODUCTS

YOU ARE ULTIMATELY RESPONSIBLE FOR VERIFYING AND VALIDATING THE SUITABILITY AND RELIABILITY OF THE PRODUCTS WHENEVER THE PRODUCTS ARE INCORPORATED IN YOUR SYSTEM OR APPLICATION, INCLUDING THE APPROPRIATE DESIGN, PROCESS, AND SAFETY LEVEL OF SUCH SYSTEM OR APPLICATION.

PRODUCTS ARE NOT DESIGNED, MANUFACTURED, OR TESTED FOR USE IN LIFE OR SAFETY CRITICAL SYSTEMS, HAZARDOUS ENVIRONMENTS OR ANY OTHER ENVIRONMENTS REQUIRING FAIL-SAFE PERFORMANCE, INCLUDING IN THE OPERATION OF NUCLEAR FACILITIES; AIRCRAFT NAVIGATION; AIR TRAFFIC CONTROL SYSTEMS; LIFE SAVING OR LIFE SUSTAINING SYSTEMS OR SUCH OTHER MEDICAL DEVICES; OR ANY OTHER APPLICATION IN WHICH THE FAILURE OF THE PRODUCT OR SERVICE COULD LEAD TO DEATH, PERSONAL INJURY, SEVERE PROPERTY DAMAGE OR ENVIRONMENTAL HARM (COLLECTIVELY, "HIGH-RISK USES"). FURTHER, PRUDENT STEPS MUST BE TAKEN TO PROTECT AGAINST FAILURES, INCLUDING PROVIDING BACK-UP AND SHUT-DOWN MECHANISMS. NI EXPRESSLY DISCLAIMS ANY EXPRESS OR IMPLIED WARRANTY OF FITNESS OF THE PRODUCTS OR SERVICES FOR HIGH-RISK USES.

# Contents

---

## Chapter 1

### Installation and Preparation

Attaching the Connector Cover .....	1-1
Connecting the Power Cord.....	1-1
RMX-4120/4121/4122/4123 (750 W Models).....	1-2
Necessary Cable .....	1-2
RMX-4124/4125/4126/4127 (1500 W Models).....	1-2
Necessary Cable .....	1-3
Switchboard Breaker Requirements .....	1-3
Connection Procedure.....	1-4
Turning the Power On .....	1-6
Turning the POWER Switch On .....	1-6
Inrush Current.....	1-7
Turning the POWER Switch Off.....	1-7
Rack Mounting .....	1-8
Load Considerations .....	1-8
Loads with Peak Current or Pulse-Shaped Current .....	1-8
Loads that Generate Reverse Current to the Power Supply .....	1-9
Loads with Accumulated Energy .....	1-9
Load Cables .....	1-10
Protecting Against Noise .....	1-11
Cabling Considerations When Using Remote Sensing .....	1-11
Connecting to the Output Terminals .....	1-12
Attaching the Output Terminal Cover.....	1-15
Sensing.....	1-17
Local Sensing .....	1-19
Remote Sensing .....	1-19
Connecting an Electrolytic Capacitor Across the Load.....	1-22
Inserting a Mechanical Switch Between the RMX Programmable Power Supply and the Load.....	1-22
Accessories .....	1-23
Parallel Operation Signal Cable .....	1-23

## Chapter 2

### Basic Functions

Measured Value Display and Setting Display .....	2-1
Measured Value Display .....	2-1
Power Display.....	2-1
Setting Display .....	2-2
Overvoltage Protection and Overcurrent Protection Setting Display.....	2-2
System Configuration Setting Display .....	2-2
Panel Operations.....	2-3

Measured Value Display, Setting Display, and Set OVP/OCP Display .....	2-3
Fine Adjustment .....	2-3
Output Operations .....	2-3
Output State at Power-up .....	2-4
Operation Overview .....	2-4
CV Power Supply and CC Power Supply .....	2-7
Crossover Point .....	2-8
CV Mode and CC Mode Operation Examples .....	2-8
Example 1 .....	2-8
Example 2 .....	2-8
Using the RMX Programmable Power Supplies as a CV or CC Power Supply .....	2-9
Protection Functions and Alarms .....	2-11
Alarm Occurrence and Clearing Alarms .....	2-12
Alarm Occurrence .....	2-12
Clearing Alarms .....	2-13
Alarm Signal .....	2-13
Protection Function Activation .....	2-14
Setting limitation functions .....	2-14
CONFIG Settings .....	2-20
Specifying CF01 to CF36, CF 41 to CF52 CONFIG Settings .....	2-24
Specifying CF00/CF40 CONFIG Settings .....	2-25
CONFIG Parameter Details .....	2-25
Preset Memory Function .....	2-39
Saving Settings to Preset Memory .....	2-39
Recalling Preset Memory Entries .....	2-40
Locking Panel Operations (Key Lock) .....	2-41
Bleeder On/Off Feature .....	2-41
Fall Time .....	2-44
Switching from Remote Mode to Local Mode .....	2-44
Factory Default Settings (Initialization) .....	2-45

## Chapter 3

### External Control

Overview .....	3-1
About the J1 Connector .....	3-1
Attaching the J1 Cable Core .....	3-2
About the J2 Connector .....	3-5
Output Terminal Insulation .....	3-7
When the Output Terminal is Not Grounded (Floating) .....	3-7
When the Output Terminal is Grounded .....	3-9
Cautions When Controlling the Output with an External Voltage (Vext) .....	3-11
Controlling the Output Voltage .....	3-12
Control Using an External Voltage (Vext) .....	3-12
External Voltage (Vext) Connection .....	3-13
Control Using an External Resistance (Rext) .....	3-13

External Resistance (Rext) Connection .....	3-14
Controlling the Output Current .....	3-14
Control Using an External Voltage (Vext) .....	3-15
Control Using an External Resistance (Rext) .....	3-16
External Resistance (Rext) Connection .....	3-16
Controlling the Output On and Off States .....	3-17
External Contact Connection .....	3-18
Long-Distance Wiring .....	3-18
Controlling Output Shutdown .....	3-19
Output Shutdown Connection .....	3-19
Long-Distance Wiring .....	3-20
Controlling the Clearing of Alarms .....	3-20
Alarm Clear Connection .....	3-21
Long-Distance Wiring .....	3-22
External Monitoring .....	3-22
Monitor Output Rating .....	3-22
External Monitoring of the Operation Status .....	3-23

## Chapter 4

### Parallel/Series Operation

Master-Slave Parallel Operation .....	4-1
Features of the RMX Programmable Power Supplies During	
Master-Slave Parallel Operation .....	4-1
Voltage Display and Current Display .....	4-1
Connection (Master-Slave Parallel Operation) .....	4-3
Connecting the Signal Cables (Parallel Operation) .....	4-3
Connecting the Load (Parallel Operation) .....	4-4
Settings (Master-Slave Parallel Operation) .....	4-6
Setting the Master Unit, the Slave Units, and the Number of Units in	
Parallel Operation (Including the Master Unit) .....	4-6
Setting the Voltage and Current .....	4-6
Setting the Overvoltage Protection (OVP) and Overcurrent Protection (OCP)	
of the Master Unit .....	4-6
Starting Master-Slave Parallel Operation .....	4-7
Turning Power On .....	4-7
Turning Power Off .....	4-7
Series Operation .....	4-8
Features of the RMX Programmable Power Supplies During Series Operation .....	4-8
Voltage Display and Current Display .....	4-8
External Control .....	4-8
External Monitoring .....	4-8
Remote Sensing .....	4-9
Alarm .....	4-10
Connection (Series Operation) .....	4-10
Connecting the Load (Series Operation) .....	4-10



- Settings (Series Operation) ..... 4-11
  - Setting the Voltage and Current ..... 4-11
  - Setting the Overvoltage Protection (OVP) and Overcurrent Protection (OCP) .. 4-11
- Starting (Series Operation) ..... 4-11
  - Turning the Power On and Off ..... 4-11
  - Turning the Output On and Off ..... 4-11

## Chapter 5 Maintenance

- Calibration Overview ..... 5-1
- Calibration Procedure ..... 5-1
  - Installation ..... 5-1
  - Launch ..... 5-1
  - Calibration Items ..... 5-2
  - Basic Instructions ..... 5-3
  - Save Calibration ..... 5-3
    - Backup Calibration Data to a XML File ..... 5-3
    - Send Calibration Data from a XML File ..... 5-3
  - Revision History ..... 5-3
  - System Requirements ..... 5-4
  - Hardware Requirements ..... 5-4
  - Environment ..... 5-4
  - Cleaning ..... 5-4
- Connection ..... 5-5

## Appendix A Specifications

## Appendix B Troubleshooting

## Appendix C NI Services

## Index

---

# Installation and Preparation

This chapter describes how to turn on an RMX programmable power supply, what kind of load cables to use, and how to connect cables to the output connectors.



**Note** Protection provided by this equipment may be impaired if it is used in a manner not described in the manual.

---

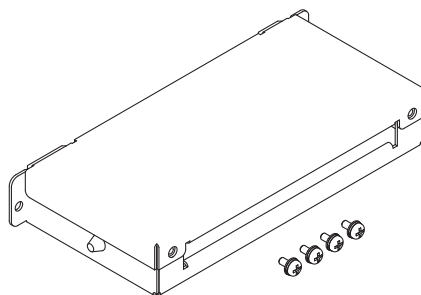
## Attaching the Connector Cover

RMX programmable power supplies are supplied with a connector cover that fits over the entire sensing, J1, and J2 connectors. For safety reasons, be sure to attach the connector cover when you use the RMX programmable power supply.

---

**Figure 1-1.** Connector Cover

---



---

## Connecting the Power Cord

This product is a piece of equipment that conforms to IEC Overvoltage Category II (equipment that consumes energy supplied from a fixed installation).

A power cord is not included with the RMX-4124/4125/4126/4127. Use a power cord that conforms to this product's rated AC input voltage, input current, and configured for the plug type. Refer to your product specifications for details.



**Caution** Risk of electric shock. This product is a piece of equipment that conforms to IEC Safety Class I (equipment that has a protective conductor terminal). Be sure to earth ground the product to prevent electric shock. The product is grounded through the power cord ground wire. Connect the protective conductor terminal to earth ground.

## RMX-4120/4121/4122/4123 (750 W Models)

### Necessary Cable

- **North America**—Extra Hard Usage Cord, min. 300 V, 60 C, 14 AWG, 3 Conductor cord, 3 m or less, with a NEMA 5-15P to C14.
- **Europe**—HAR Marked, min. 300 V, 60 C, 2.5mm<sup>2</sup>, 3 Conductor cord, 3 m or less, with a plug configured for the country of use to C14.
- **International**—Certified for country of use, min. 300 V, 60 C, 2.5mm<sup>2</sup>, 3 Conductor cord, 3 m or less, with a plug configured for the country of use to C14.

The power cord can be used to disconnect the RMX programmable power supply from the AC power line in an emergency. Connect the plug to an easily accessible power outlet so that the plug can be removed from the outlet at any time. Be sure to provide adequate clearance around the power outlet.

1. Check that the AC power line meets the nominal input rating of the product. The product can receive a nominal line voltage in the range of 100 VAC to 240 VAC at 50 Hz or 60 Hz.
2. Check that the POWER switch is turned off.
3. Connect the power cord to the AC inlet on the rear panel.
4. Insert the power plug into a grounded outlet.

## RMX-4124/4125/4126/4127 (1500 W Models)



**Caution** Risk of electric shock. Before you connect the power cord, turn off the switchboard breaker (a switch that cuts off the power supply from the switchboard).

Risk of fire. Connection to the switchboard must be performed by a person who has knowledge about electrical safety standards and the electrical aspects of regulated DC power supplies. The switchboard breaker must meet the requirements shown below.



**Caution** Inside the product, protective circuits are connected to match the polarity of the input terminal. Be sure to connect the L, N, and (GND) terminals of the product to the matching terminals on the switchboard.

In an emergency, turn off the switchboard breaker to disconnect the product from the AC power line.

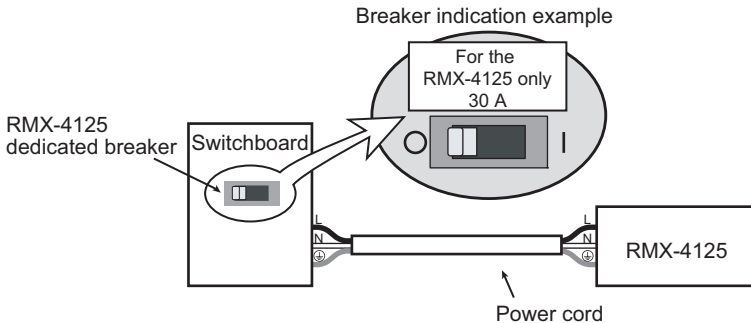
## Necessary Cable

- Vinyl cabtire cable (VCTF): Nominal cross-sectional area 5.5 mm<sup>2</sup>, 3 core
- Finished diameter: 10.5 to 14.4 mm in diameter
- Rated voltage: 250 V or higher
- Input terminal end: 14 mm of insulation stripped from conductor for the L and N wires.  
Crimping terminal: (round, M4) that fixes the cable insulation in place for the GND wire
- Length: 3 m or less

## Switchboard Breaker Requirements

- Installation must be done in accordance with national wiring rules, such as NFPA 70 "NEC" and CSA C22.1 "CEC".
- Rated current: 30 A (for safety, breakers whose rated current exceeds 30 A cannot be used)
- Do not power any other equipment from the switchboard breaker.
- Keep the breaker readily accessible at all times.
- Indicate that the breaker is dedicated for use with this product and that it is used to disconnect the product from the AC power line.

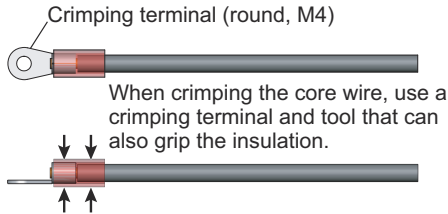
**Figure 1-2.** Switchboard Diagram



## Connection Procedure

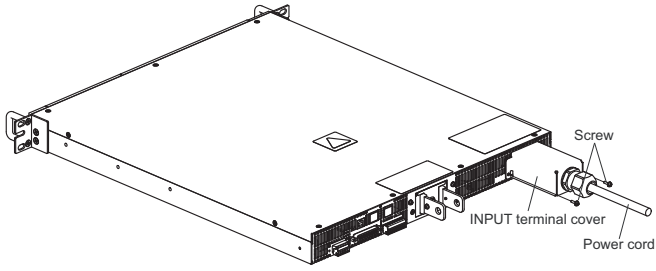
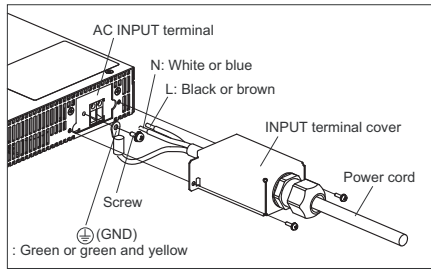
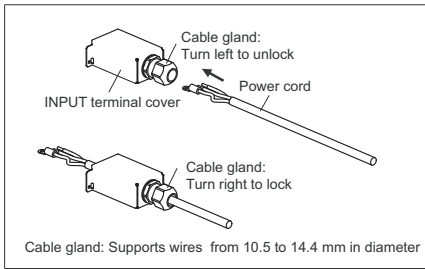
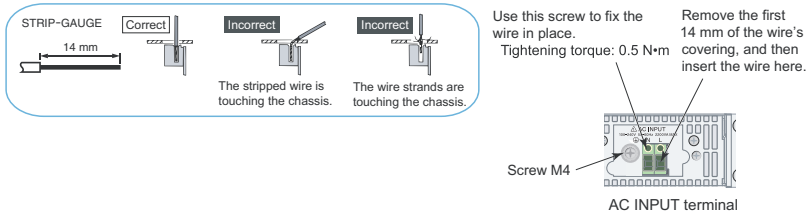
1. Check that the AC power line meets the nominal input rating of the product. The product can receive a nominal line voltage in the range of 100 VAC to 240 VAC at 50 Hz or 60 Hz.
2. Check that the POWER switch is turned off.
3. Attach a crimping terminal to the GND wire.

**Figure 1-3.** Attaching the Crimping Terminal



4. Connect the power cord and the included INPUT terminal cover to the AC INPUT terminal on the rear panel. Be sure to connect the AC INPUT L, N, and (GND) terminals correctly. Pass the power cord through the INPUT terminal cover, and fix the cord in place using the cable gland.

**Figure 1-4. Connecting the Power Cord**



5. Attach an appropriate crimping terminal to the switchboard end of the power cord.
6. Turn off the switchboard breaker.
7. Connect the L, N, and (GND) wires of the power cord to the matching terminals on the switchboard.

# Turning the Power On

---

## Turning the POWER Switch On



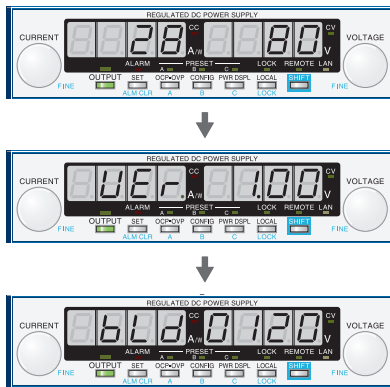
**Caution** Risk of electric shock. Regardless of whether load cables are connected to the output terminals, be sure to attach the OUTPUT terminal cover before turning the POWER switch on.

You can use the CONFIG settings to set how the RMX programmable power supplies start when you turn the POWER switch on. Depending on the setting, the output may be turned on automatically when the POWER switch is turned on. If you connect a load without setting OVP and OCP to appropriate values, the load may be damaged if the output is programmed to automatically turn on when the power is switched on.

When you turn the POWER switch on for the first time after purchase, the RMX programmable power supply will be programmed with its factory default settings. Refer to Chapter 2, *Factory Default Settings (Initialization)*, for more information about these settings. Each subsequent time you turn the power supply on, it starts with the panel settings (excluding the output on/off setting) that were in use immediately before the POWER switch was turned off.

You can use the CONFIG setting CF02 to select how the RMX programmable power supply starts when the POWER switch is turned on. Refer to Chapter 2, *CF02 Power-on Status Parameter*, for more information about this setting.

1. Check that the power cord is connected correctly.
2. Check that the OUTPUT terminal cover is attached. Refer to the *Attaching the Output Terminal Cover* section for more information about attaching the terminal cover. When the product is shipped from the factory, the OUTPUT terminal cover is not attached.
3. Turn the POWER switch on. All the LEDs light, and then the voltmeter and the ammeter display the following sequence of information: the rated voltage and rated current, the firmware version number, the build number, and then the selected interface. Each item is displayed for approximately 1 second. After a few seconds, the RMX programmable power supply enters the operation standby state during which the output value is displayed.

**Figure 1-5. Power On Information Display**


## Inrush Current

When the POWER switch is turned on, an inrush current of up to 70 A can momentarily flow into the rear AC input of the programmable power supply. Check that sufficient current capacity is available in the AC power line or the switchboard, particularly if you are using multiple RMX programmable power supplies and turning on their POWER switches simultaneously.

## Turning the POWER Switch Off

Flip the POWER switch to the side to turn RMX programmable power supplies off. The RMX programmable power supplies save the panel settings (except the output on/off setting) that were in use immediately before the POWER switch was turned off.

You can use CONFIG settings CF02 to select how the RMX programmable power supply starts when the POWER switch is turned on. Refer to Chapter 2, [CF02 Power-on Status Parameter](#), for more information about this setting.

If the POWER switch is turned off immediately after the settings have been changed, the last settings may not be stored.



**Caution** After you turn the POWER switch off, wait at least 10 seconds after the panel display turns off before you turn the POWER switch back on. Repeatedly turning the POWER switch on and off at short intervals can cause damage to the inrush current limiter. Furthermore, this will shorten the service life of the POWER switch and the internal input fuse.



# Rack Mounting

---

You can use brackets or slide rails to mount the RMX programmable power supply to a rack.

When you mount an RMX programmable power supply to a rack, install the optional support angles (NI P/N) to support the device.

NI recommends that you keep all pieces that you remove from a RMX programmable power supply during installation. You will need these pieces if you remove the device from a rack.

When using several RMX programmable power supplies together for master-slave parallel or series operation, mount them to a rack before use.

# Load Considerations

---



**Note** The output can become unstable if the following types of loads are connected.

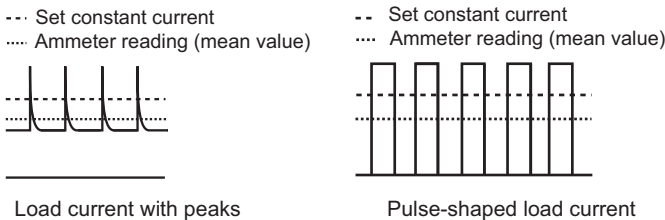
## Loads with Peak Current or Pulse-Shaped Current

The front panel of the RMX power supply only displays averaged voltage and current values. If the supply is connected to a load that draws current in spikes or pulses it is possible that the front panel will display a current reading lower than the programmed current setpoint. In reality, the spikes or pulses in the load current are exceeding the programmed current setpoint causing the supply to switch instantaneously into constant-current mode and causing the output voltage to drop.

For these types of loads, you must increase the set constant current or increase the current capacity.

**Figure 1-6.** Loads with Peak Current or Pulse-Shaped Current

---

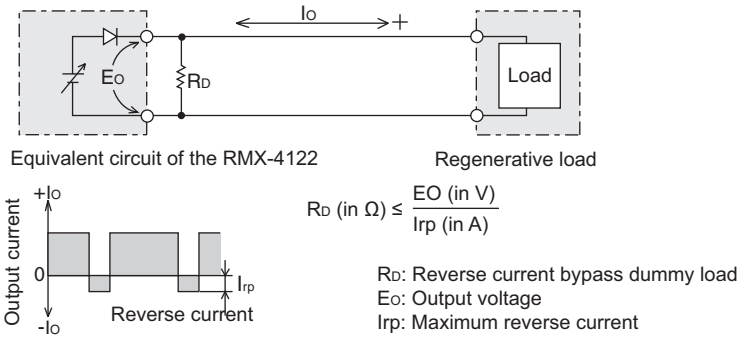


# Loads that Generate Reverse Current to the Power Supply

RMX programmable power supplies cannot sink reverse current from the load. Therefore, if a regenerative load (such as an inverter, converter, or transformer) is connected and tries to sink power into the terminals of the power supply, the output voltage will increase and can become unstable. This can cause a malfunction.

For these types of loads, connect a resistor ( $R_D$ ) as shown in the following figure to bypass the reverse current. However, the amount of current to the load decreases by  $I_{rp}$ .

**Figure 1-7. Loads with Accumulated Energy**



**Caution** Use a resistor with sufficient rated power for  $R_D$ . If a resistor with insufficient rated power for the circuit is used, the resistor will burn out.

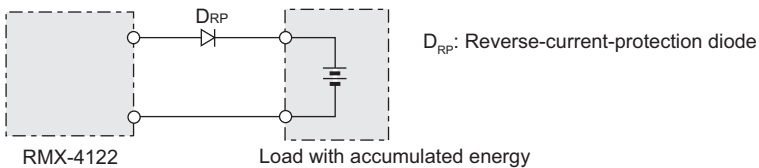
# Loads with Accumulated Energy

Connecting a load with accumulated energy, such as a battery, to an RMX programmable power supply may cause current to flow from the load to the internal circuit. This current may cause damage or reduce the life of the load.

For this type of load, connect a reverse-current-prevention diode ( $D_{RP}$ ) between the RMX programmable power supply and the load in series as shown in the following figure.

This cannot be used in conjunction with remote sensing.

**Figure 1-8. Loads with Accumulated Energy**





**Caution** To protect the load and the RMX programmable power supplies, use a  $D_{RP}$  that conforms to the following specifications.

- Reverse voltage withstand capacity—At least twice the rated output voltage of the RMX programmable power supply.
- Forward current capacity—Three to ten times the rated output current of the RMX programmable power supply.
- A diode with small loss.
- Be sure to take into account the heat generated by  $D_{RP}$ .  $D_{RP}$  will burn out with inadequate heat dissipation.

## Load Cables

---



**Caution** Risk of fire. Use load cables whose capacity is adequate for the RMX programmable power supply’s rated output current. The output connector and its surrounding area become hot. Use cables whose covers have heat resistance at 85 °C and higher.



**Caution** Risk of electric shock. Use the cable which has higher withstanding voltage than the specified insulation voltage of the product to secure the double insulation or reinforced insulation.

The current capacity of a load cable is dependent on the maximum allowable temperature of the cable's insulation.

A cable’s temperature is determined by the resistive loss based on the current, the ambient temperature, and the cable’s external thermal resistance. The following table shows the current capacity of heat-resistant vinyl wires that have a maximum allowable temperature of 60 °C, assuming that a wire is stretched out horizontally in air in an ambient temperature of 30 °C. The current capacity must be reduced under certain conditions, such as when vinyl cables that have a low heat resistance are used, when the ambient temperature is 30 °C or greater, or when cables are bundled together and little heat is radiated.

**Table 1-1.** Current Capacity of Heat-resistant Vinyl Wires

Nominal Cross-sectional Area	AWG (Reference Cross-sectional Area)	Allowable Current (Ta = 30 °C)	Recommended Current
2 mm <sup>2</sup>	14 (2.08 mm <sup>2</sup> )	27 A	10 A
3.5 mm <sup>2</sup>	12 (3.31 mm <sup>2</sup> )	37 A	—
5.5 mm <sup>2</sup>	10 (5.26 mm <sup>2</sup> )	49 A	20 A

**Table 1-1.** Current Capacity of Heat-resistant Vinyl Wires (Continued)

Nominal Cross-sectional Area	AWG (Reference Cross-sectional Area)	Allowable Current (Ta = 30 °C)	Recommended Current
8 mm <sup>2</sup>	8 (8.37mm <sup>2</sup> )	61 A	30 A
14 mm <sup>2</sup>	6 (13.3 mm <sup>2</sup> )	88 A	50 A
22 mm <sup>2</sup>	4 (21.15 mm <sup>2</sup> )	115 A	80 A
30 mm <sup>2</sup>	2 (33.62 mm <sup>2</sup> )	139 A	—
38 mm <sup>2</sup>	1 (42.41 mm <sup>2</sup> )	162 A	100 A
50 mm <sup>2</sup>	1/0 (53.49 mm <sup>2</sup> )	190 A	—
60 mm <sup>2</sup>	2/0 (67.43 mm <sup>2</sup> )	217 A	—
80 mm <sup>2</sup>	3/0 (85.01 mm <sup>2</sup> )	257 A	200 A
100 mm <sup>2</sup>	4/0 (107.2 mm <sup>2</sup> )	298 A	—
125 mm <sup>2</sup>	—	344 A	—
150 mm <sup>2</sup>	—	395 A	300 A
200 mm <sup>2</sup>	—	469 A	—

## Protecting Against Noise

When connecting wires that have the same heat resistance, separating the wires as much as possible to increase heat radiation enables a greater amount of current to flow. However, wiring the + (positive) and - (negative) output wires of the load cable side by side or bundling them together will minimize unwanted noise on the output. The currents shown in Table 1-1 are allowable currents that have been reduced in consideration of the potential bundling of load cables. Use these values as a guideline when connecting load cables.

## Cabling Considerations When Using Remote Sensing

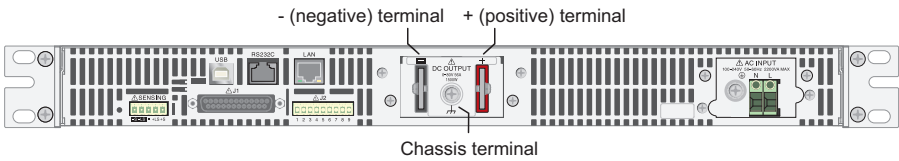
As you increase the current setpoint or increase the resistance of your load cabling, the voltage drop between the RMX power supply and your load will increase. This results in the voltage at your load being smaller than the programmed voltage setpoint. Refer to Appendix A, *Specifications*, to see the maximum voltage drop each RMX power supply's remote sense terminals can compensate for. If the voltage drop exceeds this level, use shorter load cables or cables with a greater cross-sectional area.

# Connecting to the Output Terminals



**Caution** Risk of electric shock. Turn the POWER switch off before you touch the OUTPUT terminals. Even if you turn the output off or turn the POWER switch off, if the bleeder on/off setting (CF11) is set to “OFF,” the voltage that was present when the output was on will remain at the output terminals. Turn the bleeder circuit on before you touch the output terminals. Regardless of whether load cables are connected to the output terminals, be sure to attach the OUTPUT terminal cover before turning the POWER switch on. Confirm that the voltage between any output terminal and ground is lower than the isolation voltage of the RMX programmable power supply.

**Figure 1-9.** RMX-4125 Output Terminal



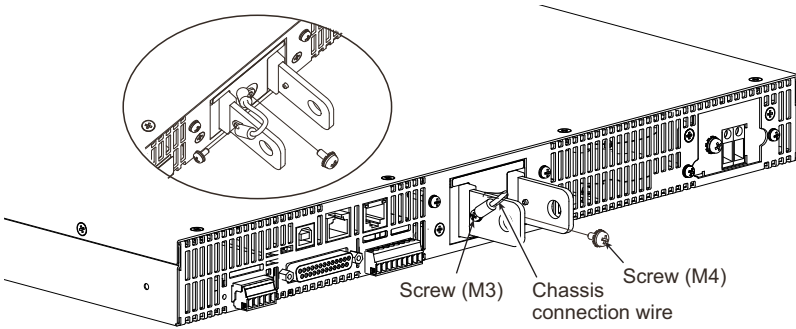
1. Turn the POWER switch off. Check that there is no voltage across the output terminals.
2. Connect one end of the included chassis connection wire to the chassis terminal, and then connect the other end of the wire to the negative or positive output terminal.



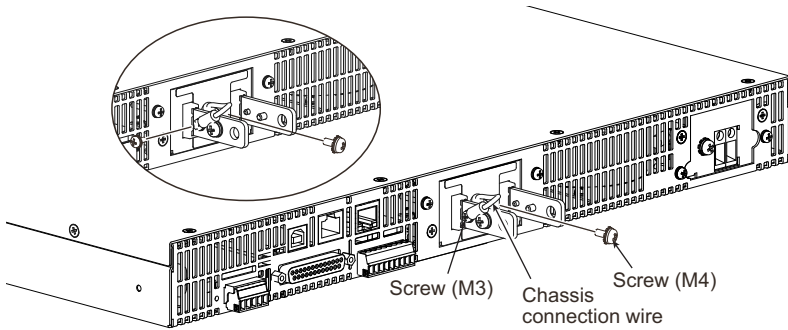
**Note** For safety reasons, connect one of the output terminals to the chassis terminal unless your application requires the output terminals to be floating.

Use the screw on the RMX to connect the wire to the chassis terminal. Use the screw on the output terminal to connect the wire to the output terminal.

**Figure 1-10.** RMX-4120/4121/4124/4125

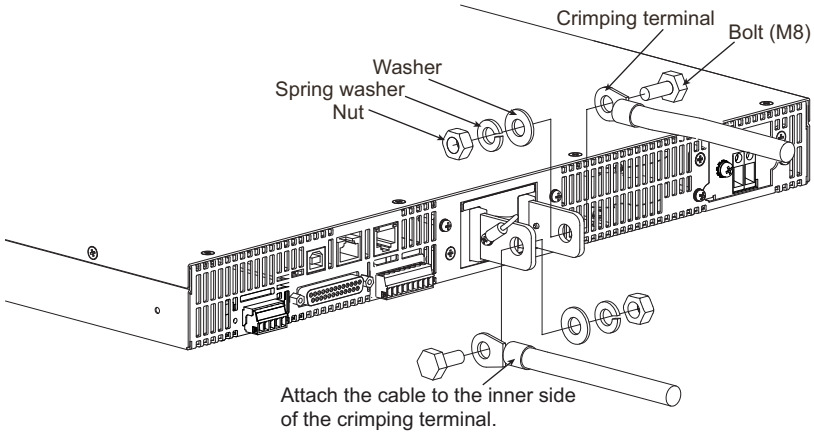


**Figure 1-11.** RMX-4122/4123/4126/4127

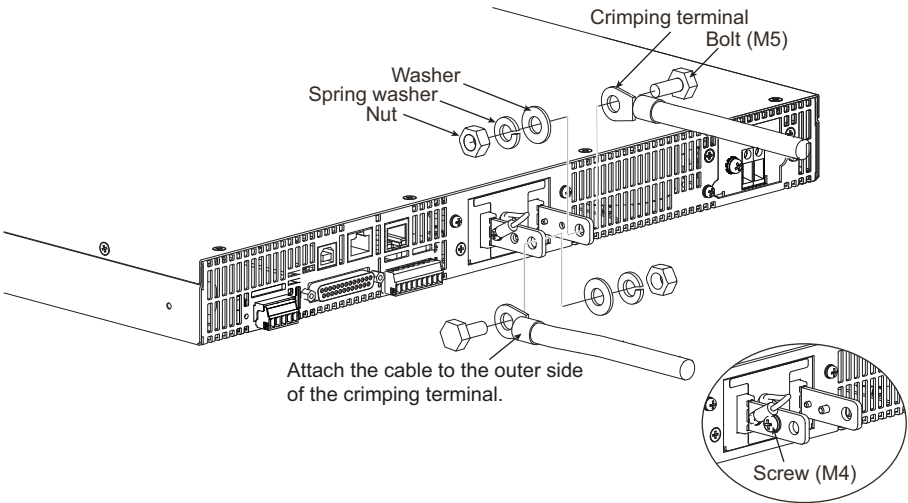


3. Attach crimping terminals to the load cables.  
The output terminals have holes for connecting the load cables. Use crimping terminals that are appropriate for the bolts that you are using.
4. Use the included bolt set to connect the load cables to the output terminals.  
Connect the positive cable to the positive output terminal and the negative cable to the negative output terminal. The orientation of the crimping terminals will vary depending on the wire diameter of the load cables used.

**Figure 1-12.** Connection Using M8 Bolt Set for RMX-4120/4121/4124/4125



**Figure 1-13.** Connection Using M5 Bolt Set for RMX-4122/4123/4126/4127



**Note** If you do not connect load cables in the correct orientation, you will not be able to attach the OUTPUT terminal cover.

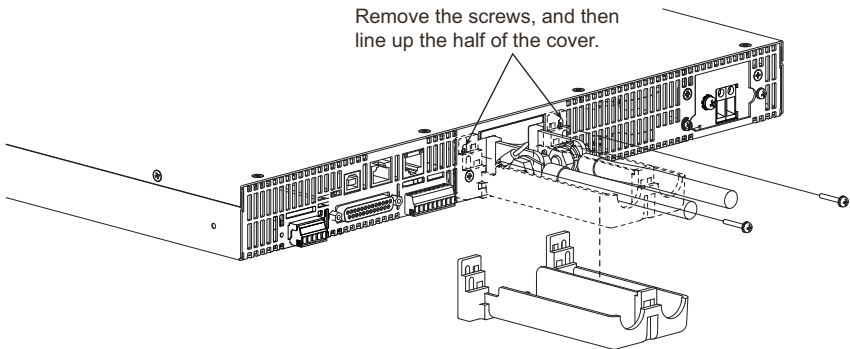
## Attaching the Output Terminal Cover

You can adjust the diameter of the holes that the load cables pass through by changing the positions in which the top and bottom halves of the OUTPUT terminal cover are put together.

There are two available positions. Use the appropriate position for the load cables that you are using.

- For cables that are up to 10 mm in diameter: Put the top and bottom halves of the OUTPUT terminal cover together so that the hole diameter is small.
  - For cables that are between 10 mm and 18 mm in diameter: Put the top and bottom halves of the OUTPUT terminal cover together so that the hole diameter is large.
1. Remove the screw that is attached next to the output terminals on the RMX. Use this screw to attach the OUTPUT terminal cover.
  2. Place the bottom half of the OUTPUT terminal cover underneath the load cables connected to the output terminals.

**Figure 1-14.** Attaching Bottom Half of the OUTPUT Terminal Cover



**Note** The top and bottom halves of the OUTPUT terminal cover have different shapes.

3. Align the tabs of the top half of the OUTPUT terminal cover with those of the bottom half. Align the tabs of the OUTPUT terminal cover according to the load cable diameter.

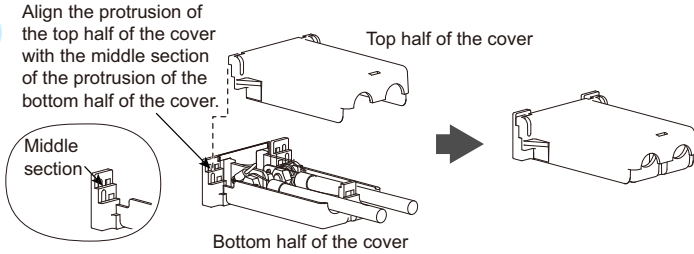


**Figure 1-15.** Aligning Both Halves of the OUTPUT Terminal Cover

For thin load cables

Cover hole diameter:  
Up to 10 mm

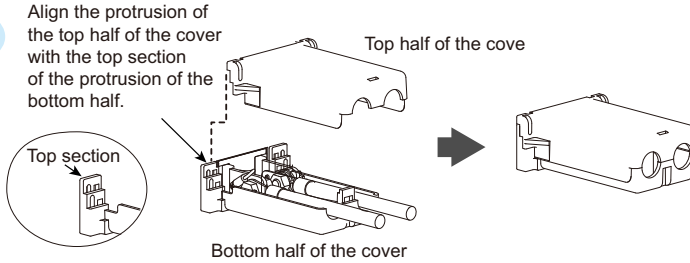
Align the protrusion of the top half of the cover with the middle section of the protrusion of the bottom half of the cover.



For thick load cables

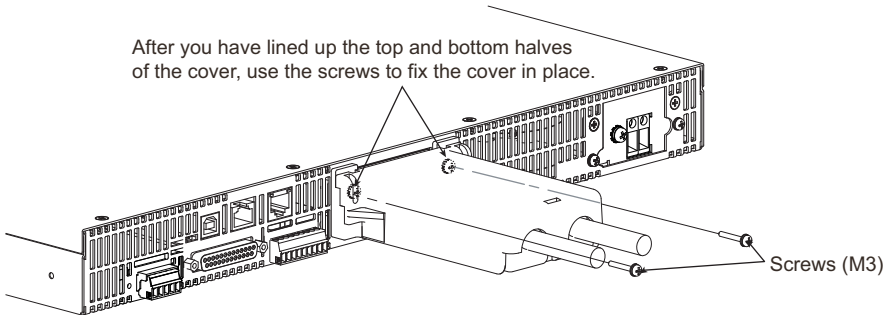
Cover hole diameter:  
10 mm to 18 mm

Align the protrusion of the top half of the cover with the top section of the protrusion of the bottom half.



4. Push the OUTPUT terminal cover against the rear panel, and then use the RMX screws to fix the cover in place. Ensure that the screws are securely fastened.

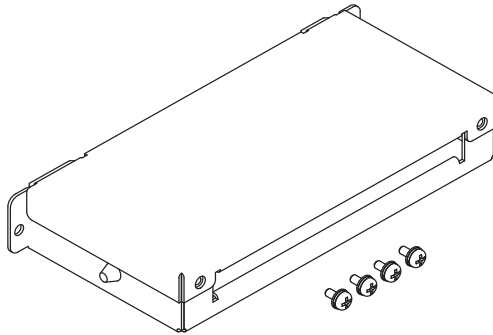
**Figure 1-16.** Attaching the OUTPUT Terminal Cover



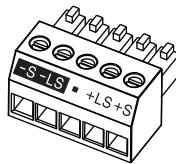
# Sensing

When RMX programmable power supplies are shipped from the factory, the connector is attached to the sensing terminals. RMX programmable power supplies are supplied with a connector cover that fits over the entire sensing, J1, and J2 connectors. For safety reasons, be sure to attach the connector cover when you use the RMX programmable power supply. If they are damaged or lost, contact National Instruments.

**Figure 1-17. Connector Cover**



**Figure 1-18. Terminal Connector**



**Caution** Risk of electric shock and damage to internal circuits.

Never wire the sensing terminals while the POWER switch is turned on.

Use sensing cables that provide reinforced or double insulation with a capacity greater than or equal to the isolation voltage of the RMX programmable power supply. For uncovered sections of the shielded cables, use insulation tubes to secure reinforced or double insulation with a capacity greater than or equal to the isolation voltage of the RMX programmable power supply.

The sensing terminals are at approximately the same electric potential as the negative output terminal. Insert the cables so that the wire strands do not touch the chassis when they stick out of the sensing terminal. Also, insert the cables so that the stripped wires do not stick out of the terminal.

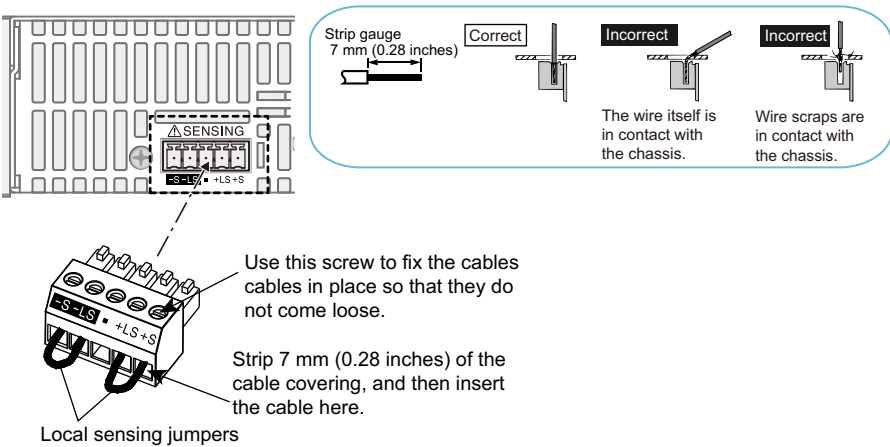
Even if you turn the output off or turn the POWER switch off, if the bleeder on/off setting (CF11) is set to OFF, the voltage that was present when the output was on will remain at the output terminals. Set the bleeder on/off setting to on before you touch the sensing terminals.

Regardless of whether local sensing or remote sensing is used, be sure to attach the sensing terminal cover before turning the POWER switch on.

If the sensing cables come loose, the output voltage across the load may become unstable, and an excessive voltage may be applied to the load. If an appropriate OVP trip point is set, the OVP will trip before an excessive voltage is generated.

When you are finished with remote sensing, return to local sensing mode.

**Figure 1-19. Sensing Cable Connections**



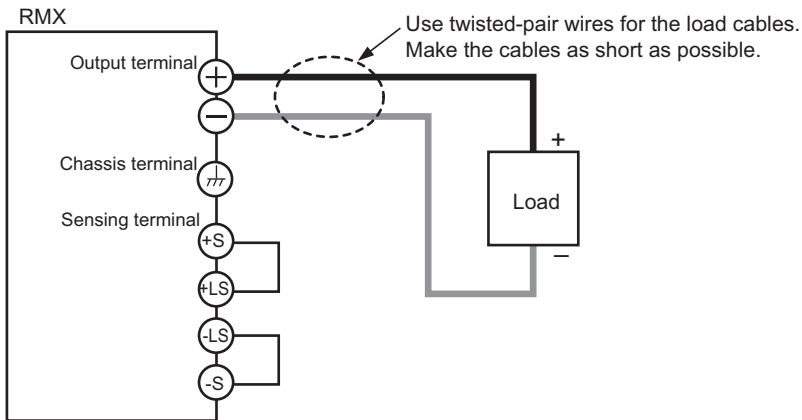
**Table 1-2. Sensing Terminals and Functions**

Terminal	Function
-S	Negative remote sensing terminal.
-LS	Negative local sensing terminal connected to the negative output terminal
—	Not connected.
+LS	Positive local sensing terminal connected to the positive output terminal.
+S	Positive remote sensing terminal.
Sensing cable: AWG28 to AWG16	

## Local Sensing

By factory default, RMX programmable power supplies are set to local sensing (the rear panel sensing connector is hard wired). The sensing point during local sensing is the output terminal. This method does not compensate for the voltage drop across the load cable, so use this method when the load current is small or when you do not need to consider the load effect voltage.

**Figure 1-20. Local Sensing**



## Remote Sensing

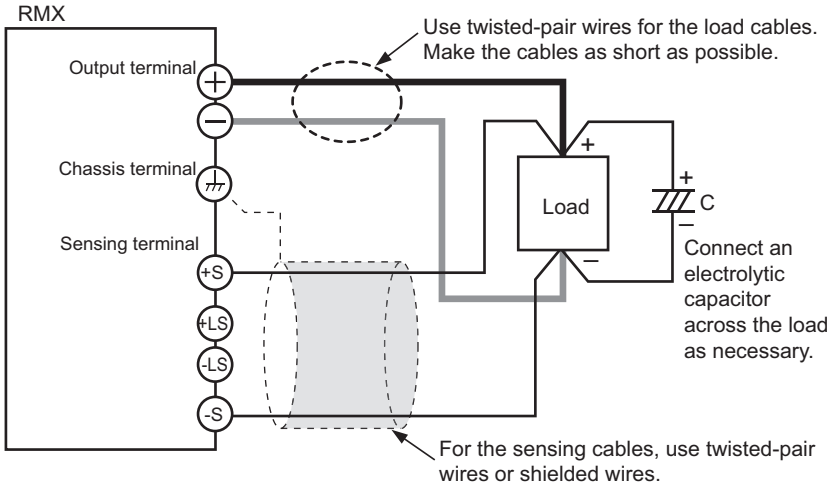
Remote sensing is a feature that reduces the effect of voltage drops across load cabling resulting in a more accurate voltage being applied at the terminals of the load.

Refer to Appendix A, *Specifications* for the maximum voltage drop each RMX power supply's remote sense terminals can compensate for. Select a load cable that has sufficient current capacity to prevent the voltage drop in the load cable from exceeding the compensation voltage. Refer to the *Load Cables* section for more information about the cables.

When using remote sensing, the output terminals compensate for the voltage drop across the load cabling by increasing the output voltage above the programmed setpoint until the sense leads detect the programmed setpoint at the load itself. This requires the output terminals to generate a voltage that is greater than the programmed voltage level. If you are performing remote sensing with the voltage close to the maximum output voltage of the power supply, the total output is still limited by the maximum output voltage at the terminals of the power supply (105% of the rated output voltage). If the signal doesn't seem to be stable, an electrolytic capacitor may be required at the sensing point (across the load).

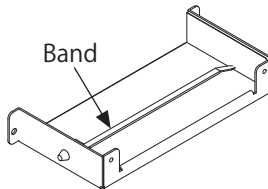
To minimize noise on the output signal, use twisted-pair wires or 2-core shielded wires. Connect the ground of your shielded wire to the ground of the RMX programmable power supply or the load.

**Figure 1-21. Remote Sensing**



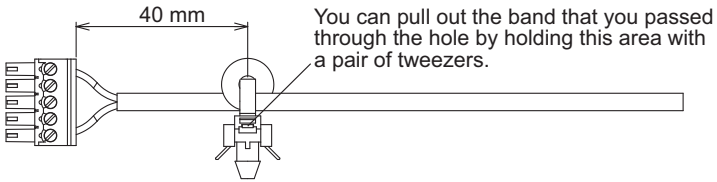
1. Turn the POWER switch off.
2. Remove the sensing connector from the rear panel sensing terminals.
3. Remove the local sensing jumpers from the sensing connector.
4. Remove 7 mm of the wire covering. Connect the negative sensing cable to -S and the positive sensing cable to +S.  
Use cable screws to securely fix the cables in place so that they do not come loose.
5. Pinch the tip of the band, and remove the band from the connector cover.

**Figure 1-22. Bottom Cover with Band**



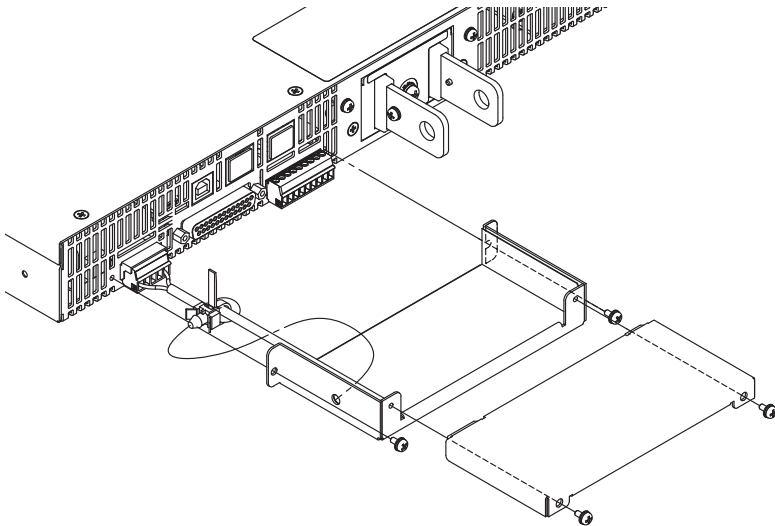
6. As shown in the figure, create a ring 40 mm away from the connector, and fasten with the band. Make the ring as small as possible, and fasten the band as tight as possible. The band can be reused. Do not cut the extraneous portion of the band.

**Figure 1-23. Sensing Wire Assembly**



7. Firmly attach the sensing connector to the sensing terminals.
8. Fasten the lower side of the connector cover to the panel with the included screws, and then insert the tip of the band into the hole of the cover. Finally, bring the top and bottom sides of the connector cover together, and fasten with the included screws.

**Figure 1-24. Connector Cover Assembly**



9. Turn the power switch on.

## Connecting an Electrolytic Capacitor Across the Load

If the cabling is largely inductive, it may be necessary to connect an electrolytic capacitor across the load. If you run into this problem, the following symptoms may appear:

- The output of the power supply is oscillating. If very long wires are used to connect the load, the inductive and capacitive components of the cable can cause phase shifting that results in oscillation at the output. You can reduce this effect by shortening the load cables. However, if this does not rectify the problem, connect an electrolytic capacitor across the load.
- If the load current is changing rapidly in a pulse-shaped pattern, the output voltage may fluctuate due to inductance in the cabling. You can reduce the inductance component by twisting the load cables, which stabilizes the voltage. However, if this does not rectify the problem, connect an electrolytic capacitor across the load.

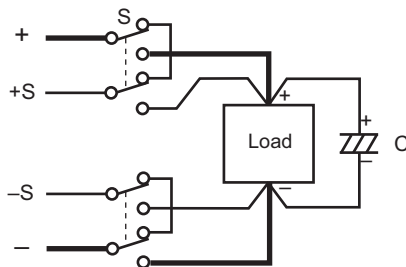
**Table 1-3.** Electrolytic Capacitor with RMX Programmable Power Supplies

RMX-4120 RMX-4124	RMX-4121/ RMX-4125	RMX-4122/ RMX-4126	RMX-4123/ RMX-4127
36 V or more	96 V or more	276 V or more	780 V or more
Capacitance: 0.1 $\mu$ F to a few hundred $\mu$ F. Withstand voltage: At least 120% of the rated output voltage of the RMX programmable power supply.			

## Inserting a Mechanical Switch Between the RMX Programmable Power Supply and the Load

If you want to connect and disconnect the load using a mechanical switch that is inserted between the RMX programmable power supply and the load, be sure to include switches in the sensing cables as shown in the following figure. Also make sure to turn on and off the load cable and sensing cables simultaneously. Before you turn the mechanical switch on or off, be sure to turn the output or the POWER switch off.

**Figure 1-25.** Mechanical Switch in a Sensing Cable



# Accessories

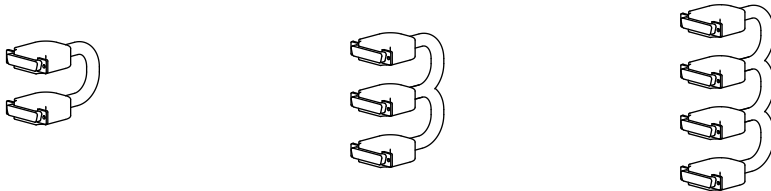
RMX programmable power supplies have the following available accessories. For more information about accessories contact National Instruments.

## Parallel Operation Signal Cable

This cable is used when you perform parallel operations. The following three types are available:

Part Number	Description
784821-01	Cable Assembly, RMX-412x Parallel Operation (2 units)
784822-01	Cable Assembly, RMX-412x Parallel Operation (3 units)
784823-01	Cable Assembly, RMX-412x Parallel Operation (4 units)

**Figure 1-26.** Parallel Operation Signal Cable





# Basic Functions

This chapter describes how to turn the output on and off and the basic operations that you can perform from the front panel.

## Measured Value Display and Setting Display

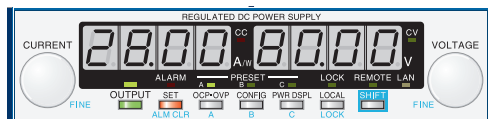
The voltage and current displays have the following two states:

- Measured value display
- Setting display

### Measured Value Display

When the SET key LED is off, the front panel will display the measured value of the voltage and current at the output terminals. You can still change the output voltage and current settings while in this state, but the front panel will continue to display the values measured at the output. Refer to the [Using the RMX Programmable Power Supplies as a CV or CC Power Supply](#) section for more information about these functions.

**Figure 2-1.** Measured Value Display



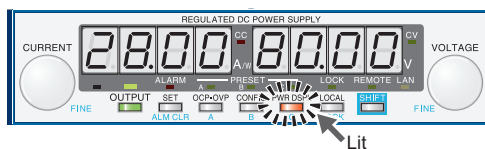
### Power Display

While in the measured value display, press PWR DSPL to display the output power on the ammeter.

The output power is calculated from the measured output voltage and the measured output current.

When displaying the output power, the PWR DSPL key LED will light up. Press PWR DSPL again to return to measured value display.

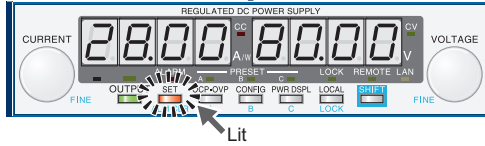
**Figure 2-2.** Power Display



## Setting Display

Press SET to display the present output voltage and output current settings, which will cause the SET key LED to illuminate. Press SET again to return to the measured value display.

**Figure 2-3. Setting Display**

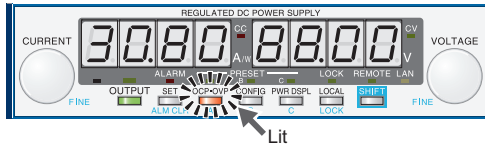


When you recall a preset memory entry, the values stored in the preset memory entry are displayed on the panel.

## Overvoltage Protection and Overcurrent Protection Setting Display

Press OCP•OVP to light its LED and display the present overcurrent protection and overvoltage protection settings.

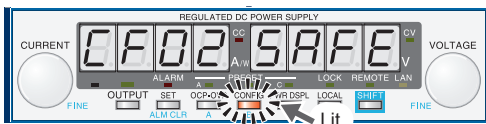
**Figure 2-4. OCP and OVP Display**



## System Configuration Setting Display

Press CONFIG to light its LED and display the present system configuration settings. Refer to the [CONFIG Settings](#) section for detailed information about these settings.

**Figure 2-5. System Configuration Setting Display**

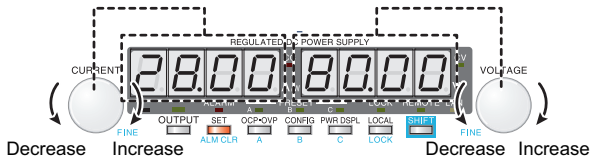


# Panel Operations

## Measured Value Display, Setting Display, and Set OVP/OCP Display

Turn the VOLTAGE knob to change the voltage. Turn the CURRENT knob to change the current.

**Figure 2-6.** Panel Operations



While in setting display mode (the SET key LED is illuminated), turning the VOLTAGE and CURRENT knobs will update the output voltage and current settings.

You cannot set the output voltage to a value that is 95% of the OVP trip point or higher. You cannot set the output current to a value that is 95% of the OCP trip point or higher.

The displayed current or voltage may not change when you turn the CURRENT or VOLTAGE knob. This is because the values are being changed at a finer resolution than the front panel can display. The display will update when the amount that you change the value by reaches the smallest display digit of the set voltage or current.

### Fine Adjustment

Holding down the SHIFT key while turning the VOLTAGE or CURRENT knobs allows for finer adjustment of the programmed voltage and current values.



**Note** When you set a value, it is convenient to first use normal resolution to set the value roughly and then switch to fine resolution to set it precisely.

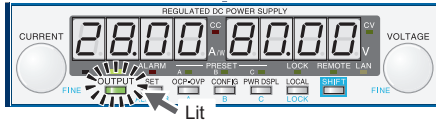
## Output Operations

The toggles each time you press OUTPUT. When output is on, the OUTPUT LED in the display area lights. When the output is off, the OUTPUT LED in the display area turns off.

When the OUTPUT key LED is on, the power supply will drive its output terminals to a level determined by the voltage and current settings. If you change the settings while the output is on, the changes are applied immediately to the output. If you change the settings while the output is off, the device will switch to setting display mode (the SET key LED will light up). Pressing OUTPUT will apply and drive the output terminals using the new settings.

You can use external control to toggle the output as well. Refer to Chapter 3, *External Control*, for additional information. CONFIG setting CF12 can be used to program the device to prioritize CC or CV mode at startup.

**Figure 2-7. Output Operations**



## Output State at Power-up

In the factory default settings, the output is off when the RMX programmable power supply turns on. Using CONFIG parameter CF02, you can set the RMX programmable power supply so that output is turned on at power on.

If you set the RMX programmable power supply so that output is turned on at power on, be sure to check that the OVP trip point is set appropriately before you turn the RMX programmable power supply off.



**Caution** If you change the load, it may be damaged if the RMX programmable power supply OVP and OCP settings are not correct.

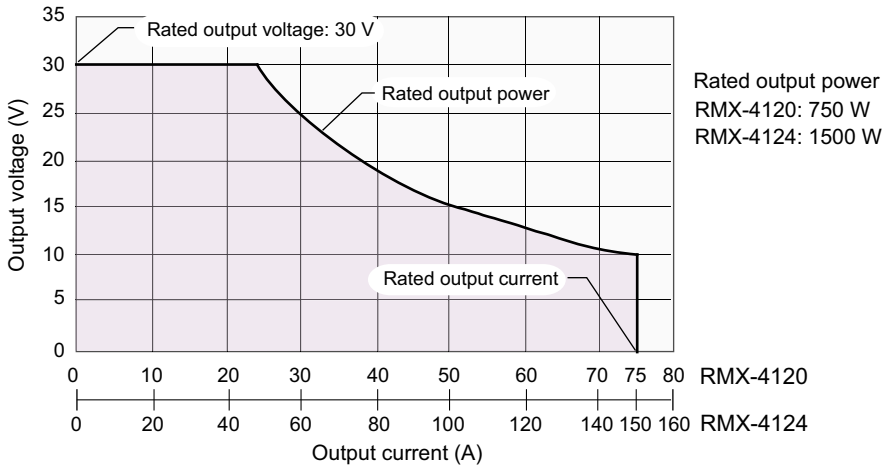
## Operation Overview

The RMX programmable power supply is a constant voltage (CV)/constant current (CC) regulated DC power supply that can output a wide range of voltage and current within rated output power.

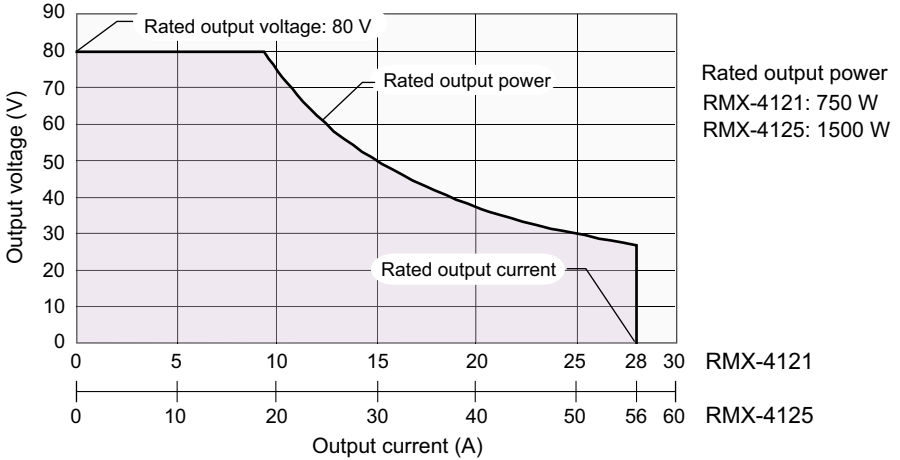
If you configure the settings so that **output voltage × output current** is less than or equal to the rated output power, the RMX programmable power supply operates as a traditional constant-voltage (CV)/constant-current (CC) power supply.

If you configure the settings so that “output voltage × output current” is greater than the rated output power, the actual output is limited by the power limit (approximately 105% of the rated output power), and the output voltage and output current change depending on the load value.

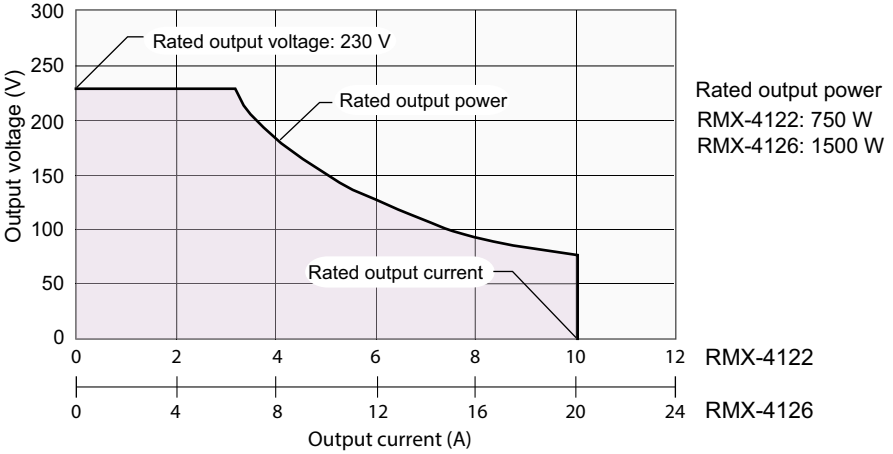
**Figure 2-8. RMX-4120/4124 Output Power**



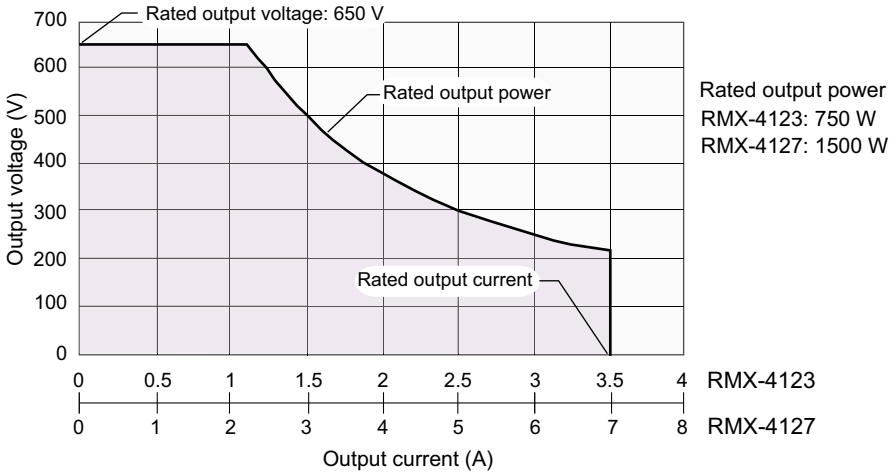
**Figure 2-9. RMX-4121/4125 Output Power**



**Figure 2-10. RMX-4122/4126 Output Power**



**Figure 2-11. RMX-4123/4127 Output Power**



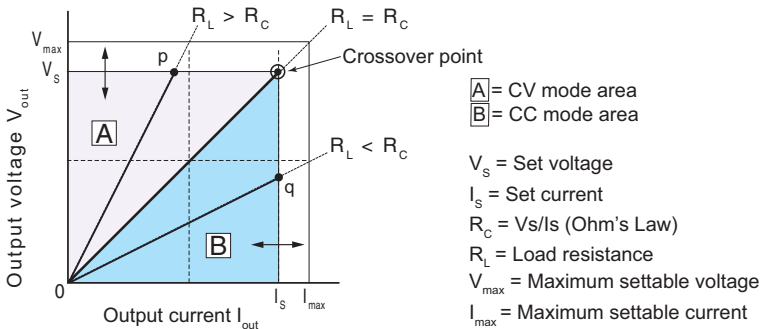
# CV Power Supply and CC Power Supply

The RMX programmable power supply can operate in constant-voltage (CV) or constant-current (CC) mode. The operation mode is determined by the following three values.

- The set output voltage ( $V_S$ )
- The set output current ( $I_S$ )
- The load resistance ( $R_L$ )

The operation modes are described below.

**Figure 2-12.** RMX Programmable Power Supplies Operation Modes



The above figure shows the operation modes of an RMX programmable power supply. The load resistance is denoted as  $R_L$ . The compliance resistance  $R_C$  is calculated from the set voltage and current ( $R_C = V_S/I_S$ ). The power supply is designed so that it operates in CV mode in area A and CC mode in area B. The boundary between the two operation modes is the line defined by  $R_L = R_C$ . This line represents the load at which the output voltage equals the set voltage and the output current equals the set current. If load resistance  $R_L$  is greater than the compliance resistance  $R_C$ , the operating point falls in area A, and the RMX programmable power supply will operate in CV mode (point p). In this case, the set current  $I_S$  operates as a current limit.

When operating in CV mode, the output voltage is maintained at the programmed voltage setpoint. The output current  $I$  is determined by the equation  $I = V_S/R_L$  and is less than current limit  $I_S$ . The actual current that flows is determined by the voltage setpoint and the load resistance and will not necessarily be equal to the programmed value.

For loads which may cause transient current spikes, current  $I_S$  must be set so that the peak value does not reach the current limit.

Conversely, if load resistance  $R_L$  is less than the compliance resistance  $R_C$ , the operating point falls in area B, and the RMX programmable power supply operates in CC mode (point q). In this case, set voltage  $V_S$  operates as a voltage limit.

When operating in CC mode, the output current is maintained at the programmed current setpoint. The output voltage  $V$  is determined by the equation  $V = I_S \times R_L$  and is less than voltage limit  $V_S$ . The actual voltage that flows is determined by the current setpoint and the load resistance and will not necessarily be equal to the programmed value.

For loads that generate transient voltage spikes,  $V_S$  must be set so that the surge voltage does not reach the voltage limit.

## Crossover Point

The RMX programmable power supply switches automatically between CV mode and CC mode according to the changes in the load. A crossover point is the point at which the mode switches.

For example, when operating in CV mode, if the load changes and the output current reaches the current limit, the RMX programmable power supply automatically switches to CC mode to protect the load. Likewise, when operating in CC mode, if the output voltage reaches the voltage limit, the RMX programmable power supply switches to CV mode.

## CV Mode and CC Mode Operation Examples

This section uses a power supply with a rated output voltage of 100 V and a rated output current of 10 A as an example.

### Example 1

A load resistance ( $R_L$ ) of 8  $\Omega$  is connected to the output terminals of the power supply. The output voltage and output current are set to 30 V and 5 A, respectively. In this case,  $R_C = 30 \text{ V} / 5 \text{ A} = 6 \Omega$ . Because 8  $\Omega$  is greater than 6  $\Omega$  ( $R_L > R_C$ ), the power supply operates in CV mode. When you want to increase the voltage in CV mode, you can increase the voltage up to the voltage defined by the following equation:  $V_S = I_S \times R_L$ . Substituting the values, obtains  $V_S = 5 \text{ A} \times 8 \Omega = 40 \text{ V}$ . If you try to increase the voltage above this point, the crossover point is reached, and the power supply automatically switches to CC mode. To maintain operations in CV mode, increase the current limit.

### Example 2

Next, a load resistance ( $R_L$ ) of 5  $\Omega$  is connected to the output terminals of the power supply. The output voltage and output current are set to 30 V and 5 A, respectively. In this case,  $R_C = 30 \text{ V} / 5 \text{ A} = 6 \Omega$ . Because 5  $\Omega$  is less than 6  $\Omega$  ( $R_L < R_C$ ), the power supply operates in CC mode. When you want to increase the current in CC mode, you can increase the current up to the current defined by the following equation:  $I_S = V_S / R_L$ . Substituting the values, obtains  $I_S = 30 \text{ V} / 5 \Omega = 6 \text{ A}$ . If you try to increase the current above this point, the crossover point is reached, and the power supply automatically switches to CV mode. To maintain operations in CC mode, increase the voltage limit.



# Using the RMX Programmable Power Supplies as a CV or CC Power Supply

When using the RMX programmable power supply as a constant-voltage power supply, the set current is the limit to the current that can flow through the load.

When using a RMX programmable power supply as a constant-current power supply, the set voltage is the limit to the voltage that can be applied to the load.

If the specified limit is reached, the RMX programmable power supply automatically switches its operation mode. When the RMX programmable power supply switches its operation mode, the lit LED in the display area (CV LED or CC LED) changes to indicate the switch.

1. Turn the POWER switch off.
2. Connect the load to the output terminals.
3. Turn the POWER switch on. If the OUTPUT LED in the display area is lit, press OUTPUT to turn the output off.
4. Press SET to change to the setting display. The SET key lights.
5. Turn the VOLTAGE knob to set the voltage.

<b>Voltage Range: 0 to 105% of the Rated Output Voltage</b>	
RMX-4120	0 to 31.5 V
RMX-4121	0 to 84 V
RMX-4122	0 to 241.5 V
RMX-4123	0 to 682.5 V
RMX-4124	0 to 31.5 V
RMX-4125	0 to 84 V
RMX-4126	0 to 241.5 V
RMX-4127	0 to 682.5 V

6. Turn the CURRENT knob to set the current.

<b>Current Range: 0 to 105% of the Rated Output Voltage</b>	
RMX-4120	0 to 78.75 A
RMX-4121	0 to 29.4 A
RMX-4122	0 to 10.5 A
RMX-4123	0 to 3.675 A
RMX-4124	0 to 157.5 A
RMX-4125	0 to 58.8 A
RMX-4126	0 to 21 A
RMX-4127	0 to 7.35 A

7. Press OUTPUT to turn output on.

The SET LED turns off, and the OUTPUT LED in the display area lights. The voltage and current are generated from the output terminals. When the device is operating as a constant-voltage power supply, the CV LED in the display area lights. When the device is operating as a constant-current power supply, the CC LED lights.

Even when the output is on, you can set the voltage and current by carrying out steps 5 and 6. Note that the front panel display will continue to display the actual measured voltage or current values rather than the programmed setpoints that you are adjusting. You can also adjust the voltage and current setpoints while displaying the output power by using the PWR DSPL key.

You can use CONFIG setting CF12 to tell the device to prioritize CV or CC mode when powering on the output. Set this according to the operation mode that you are using. You can prevent overshoot from occurring when the output is turned on by prioritizing CV when using the RMX programmable power supply as a constant-voltage power supply and by prioritizing CC when using the RMX programmable power supply as a constant-current power supply.

When used as a slave device, CONFIG setting CF12 is automatically set to CC. To use the RMX programmable power supply as a standalone unit or master unit after using it as a slave unit, set the operation mode that you want to use. If you do not set the operation mode, CC will continue to be prioritized.

When the output is turned on, the power supply's internal capacitors are charged. Depending on the programmed current setpoint, the device may enter CC mode for an instant.

# Protection Functions and Alarms

---

RMX programmable power supplies are equipped with the following protection functions:

- Overvoltage protection (OVP)
- Overvoltage protection 2 (OVP2)
- Overcurrent protection (OCP)
- Undervoltage limit (UVL)
- Overheat protection (OHP)
- Overheat protection 2 (OHP2)
- Fan failure protection (FAN)
- Incorrect sensing connection protection (SENSE)
- Low AC input protection (AC-FAIL)
- Shutdown (SD)
- Power limit (POWER LIMIT)
- Communication monitoring (WATCHDOG)

# Alarm Occurrence and Clearing Alarms

## Alarm Occurrence

When a protection function is activated, RMX programmable power supplies behave as follows.

**Figure 2-13.** OHP Alarm Indication with Output Off



**Figure 2-14.** OHP Alarm Indication with Output On



- The output turns off. CONFIG setting CF03 allows the user to set the error clearing method for overheat protection (OHP), fan failure protection (FAN), and low AC input protection (AD-FAIL) errors. When CF03 is set to Auto, the output will automatically turn back on when the problem that caused the alarm is fixed. When CF03 is set to Safe, the output will remain off even after the problem that caused the alarm is resolved. This parameter is the same for the OHP, FAN, and AC-FAIL alarms. You cannot set this parameter separately for each protection function.
- The ALARM LED in the front panel display area lights to indicate that an alarm has occurred. The voltmeter display indicates the cause of the alarm.
- The ALARM LED on the front panel blinks only when a POWER LIMIT alarm has occurred.
- The OUTPUT LED on the front panel blinks orange only when a protection function has been activated while the output is on.

If the RMX programmable power supply is set so that output turns on automatically after the problem that caused the alarm is fixed (CF03: Auto), the OUTPUT LED lights automatically when the problem that caused the alarm is fixed. If the RMX programmable power supply is set so that output remains off even after the problem is fixed (CF03: SAFE), the OUTPUT LED remains off even after the problem that caused the alarm is fixed.

- The alarm signal is generated from pin 14 of the J1 connector (when the OVP/ OVP2/OCP/ OHP/ OHP2/ FAN/ SEN/ AC-FAIL/ SD/ WATCHDOG has been activated).



**Note** When a CONFIG parameter is being displayed, only the ALARM LED turns on; the cause of alarm is not displayed. To view the cause of the alarm, exit from the CONFIG parameter display.

## Clearing Alarms

To clear alarms, (press ALM CLR (SHIFT+SET)); (2) set pin 5 of the J1 connector to LOW (0 to 0.5 V) or shorted; or (3) turn the RMX programmable power supply off, fix the problem that caused the alarm, and then turn the RMX programmable power supply on.

If overvoltage protection 2 (OVP2), overheat protection 2 (OHP2) or Shutdown (SD) has been activated, turn the RMX programmable power supply off, fix the problem that caused the alarm, and then turn the RMX programmable power supply on.

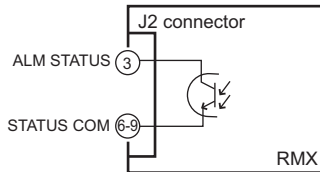
When the overheat protection (OHP), fan failure protection (FAN), or low AC input protection (AC-FAIL) function is activated, the output is turned off. You can use the CONFIG settings to select how the RMX programmable power supply will perform after the problem that caused the alarm is fixed. You can select to turn the output back on automatically after the problem that caused the alarm is fixed (CF03: Auto) or to leave the output off (CF03:SAFE).

If an alarm still occurs even after you have corrected all the causes of alarms, the RMX programmable power supply may be malfunctioning. Stop using it immediately, and contact National Instruments. For details about the specific conditions that cause each alarm to trigger, see the explanation of each protection function.

## Alarm Signal

The alarm signal is isolated from other terminals as it is through an open collector photocoupler. Maximum voltage is 30 V and maximum current is 8 mA.

**Figure 2-15.** Alarm Signal



# Protection Function Activation

## Setting limitation functions

You can use the CONFIG settings to apply limits to the voltage and current output settings. You can set limitations so that the programmed values cannot exceed the set overvoltage protection (OVP trip point) and the set overcurrent protection (OCP trip point) and so that the values cannot be lower than the set undervoltage limit (UVL trip point).

By using this feature, you can avoid accidentally turning the output off by mistakenly setting the voltage or current to a value that exceeds the set OVP or OCP or to a value that is lower than the set UVL.

If you have selected to limit the voltage setting (CF15: on), the valid programmable voltage values will be limited to voltages that are less than 95% of the OVP trip point and voltages that are greater than the UVL trip point. In addition, you will no longer be able to set the OVP trip point to a value that is lower than the set output voltage or the UVL trip point to a value that exceeds the set output voltage.

If you have selected to limit the current setting (CF14: on), the valid programmable current values will be limited to currents that are less than 95% of the OCP trip point. In addition, you will no longer be able to set the OCP trip point to a value that is lower than the set output current.

## Overvoltage Protection (OVP), Overvoltage Protection 2 (OVP2), and Overcurrent Protection (OCP)

The overvoltage protection (OVP) function is activated under the following conditions.

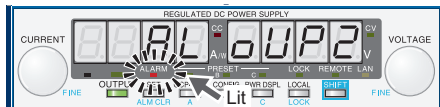
- When the output terminal voltage exceeds the set OVP trip point.
- When the load or the RMX programmable power supply is malfunctioning.

The overvoltage protection 2 (OVP2) function is activated under the following conditions.

- When the output terminal voltage exceeds 120% of the rated output voltage (when a voltage is being applied from an external source).
- When the load or the RMX programmable power supply is malfunctioning.

If OVP2 is activated, turn the POWER switch off and on.

**Figure 2-16.** Alarm When OVP2 has been Activated



The overcurrent protection function (OCP) is activated under the following conditions.

- When the output current exceeds the set OCP trip point.

- When the load or the RMX programmable power supply is malfunctioning.

Set the OVP and OCP trip points to appropriate values. Immediately after you purchase the RMX programmable power supply or immediately after a load is changed, you have to set the OVP and OCP trip points to values that are appropriate for the load.

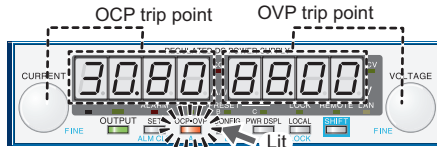
The OVP2 trip point is fixed to 120% of the rated output voltage.

	RMX-4120/ RMX-4124	RMX-4121/ RMX-4125	RMX-4122/ RMX-4126	RMX-4123/ RMX-4127
<b>OVP2 Trip Point</b>	36 V	96 V	276 V	780 V

**Setting the OVP and OCP Trip Points and the Detection Time of OCP Activation**  
 OVP will trigger based on the voltage at the output terminals of the power supply. If you want to activate the protection function according to the voltage across the load, take the voltage drop in the load cable into consideration when you set the OVP trip point.

You can use the CONFIG settings to set the detection time of the OCP activation (CF13)

**Figure 2-17. OVP and OCP Trip Point Displays**



1. Press OCP•OVP.  
 The OCP•OVP key LED lights up, and the OVP trip point and OCP trip point are displayed in the display area.
2. While viewing the panel display, turn the VOLTAGE knob to set the OVP trip point or the CURRENT knob to set the OCP trip point.  
 OVP setting range: 10% to 112% of the rated output voltage  
 OCP setting range: 10% to 112% of the rated output current

	RMX-4120/ RMX-4124	RMX-4121/ RMX-4125	RMX-4122/ RMX-4126	RMX-4123/ RMX-4127
<b>OVP Setting</b>	3 to 33.6 V	8 to 89.6 V	23 to 257.6 V	65 to 728 V
<b>OCP Setting 750 W</b>	7.5 to 84 A	2.8 to 31.36 A	1 to 11.2 A	0.35 to 3.92 A
<b>OCP Setting 1500 W</b>	15 to 168 A	5.6 to 62.72 A	2 to 22.4 A	0.7 to 7.84 A

3. Press OCP•OVP twice to finalize the settings.

The OCP•OVP key LED turns off, and the RMX programmable power supply returns to the measured value display.

## Checking OVP and OCP Operation

The OVP and OCP functions are designed to protect the load.

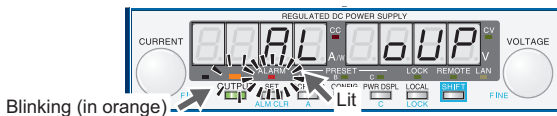
If you use the CONFIG settings to limit the voltage setting (CF15: ON), you will no longer be able to set the output voltage to a value that exceeds the OVP trip point. This means that you won't be able to check the operation of the OVP function. If you use the CONFIG settings to limit the current setting (CF14: ON), you will no longer be able to set the output current to a value that exceeds the OCP trip point. This means that you won't be able to check the operation of the OCP function.

Complete the following steps to check the operation of the OVP function. Ensure CF15 is set to OFF.

1. Check that the OUTPUT LED in the display area is turned off.
2. Set the output voltage to a value lower than the OVP trip point.
3. Press OUTPUT to turn output on. The OUTPUT LED lights.
4. Slowly turn the VOLTAGE knob clockwise.

When the output voltage exceeds the OVP trip point, the front panel display area's ALARM LED lights and the OUTPUT LED blinks to indicate that the OVP function has been activated.

**Figure 2-18.** Display of the OVP Activation Alarm



5. Check that output has turned off.
6. Turn the POWER switch off.

Complete the following steps to check the operation of the OCP function. Ensure CF14 is set to OFF.

1. Short the output terminal.
2. Turn the POWER switch on.
3. Check that the OUTPUT LED in the display area is turned off.
4. Set the output current to a value lower than the OCP trip point.
5. Press OUTPUT to turn output on. The OUTPUT LED lights.
6. Slowly turn the CURRENT knob clockwise.

When the output current exceeds the OCP trip point, the front panel display area's ALARM LED lights, and the OUTPUT LED blinks to indicate that the OCP function has been activated.



**Figure 2-19.** Display of the OCP Activation Alarm



7. Check the output has turned off.

If you do not change the output settings, the OVP or OCP function will be activated again.

### Undervoltage Limit (UVL)

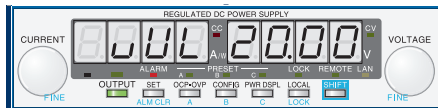
This protection function is activated when you attempt to set the output voltage to a value that is lower than the set undervoltage limit (the UVL trip point). In other words, it prevents you from setting the output voltage to a value lower than the set limit. Triggering this protection function does not turn the output off.

CONFIG setting CF15 allows you to choose whether the output setpoint is limited so that it cannot be set to a value lower than the UVL trip point.

Complete the following steps to set the UVL trip point.

1. Press OCP•OVP.  
The OCP•OVP key lights, and the OVP trip point and OCP trip point are displayed in the display area.
2. Press OCP•OVP again. The present UVL trip point is displayed.

**Figure 2-20.** Display Example of the UVL Setting



3. While viewing the panel display, turn the VOLTAGE knob to set the UVL trip point.

**Table 2-1.** UVL Setting Range 0 to 105% of the Rated Output Voltage

	RMX-4120/ RMX-4124	RMX-4121/ RMX-4125	RMX-4122/ RMX-4126	RMX-4123/ RMX-4127
<b>UVL Setting</b>	0 to 31.5 V	0 to 84 V	0 to 241.5 V	0 to 682.5 V

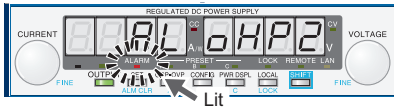
4. Press OCP•OVP to finalize setting.

## Overheat Protection (OHP), Overheat Protection2 (OHP2)

This protection function is activated when the RMX programmable power supply internal temperature rises to an abnormal level. Abnormal temperature levels can occur under the following conditions:

- When used in an environment outside its operating ambient temperature range 0°C (32°F) to 50°C (122 °F)
- When used with its air inlet and exhaust port blocked.
- When the fan motor has stopped.

**Figure 2-21.** Alarm Indication when OHP2 has been Activated



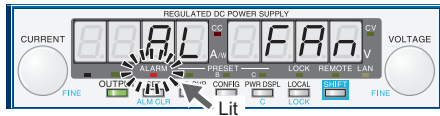
If OHP2 is activated, turn the POWER switch off and on.

If you do not fix the problem that caused the OHP or OHP2 to be activated, OHP or OHP2 will be activated again even if you restart the RMX programmable power supply.

## Fan Failure Protection (FAN)

This function is activated when the number of fan rotations drops to an abnormal level.

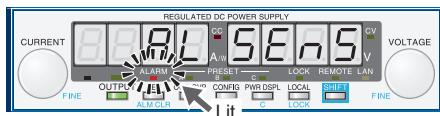
**Figure 2-22.** Alarm Indication when FAN has been Activated



## Incorrect Sensing Connection Protection (SENSE)

This function is activated when the remote sensing cables are connected with the incorrect polarity (positive or negative), and the remote sensing function is then used.

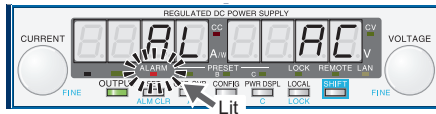
**Figure 2-23.** Alarm Indication when SENSE has been Activated



## Low AC Input Protection (AC-FAIL)

This function is activated when a low AC input is detected.

**Figure 2-24.** Alarm Indication when (AC-FAIL) has been Activated

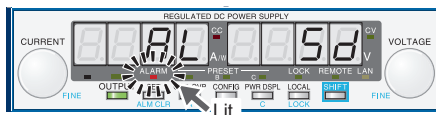


### Shutdown (SD)

Shutdown (SD) is not activated as a result of the RMX programmable power supply detecting an error. It is a function that is used to turn the output off through the application of a signal to pin 6 of the rear-panel J1 connector when an abnormal condition occurs.

If SD is activated, turn the POWER switch off and on.

**Figure 2-25.** Alarm Indication when SD has been Activated



### Power Limit (Power Limit)

This function changes the output voltage or output current according to the changes in the load resistance. This function limits the output power to a value that is approximately 105% of the rated output power. This function does not turn the output off.

When the power limit function has been activated, the ALARM LED blinks. An alarm signal is not transmitted.

**Table 2-2.** Power Limits

750 W Model	1500 W Model
787.5 W	1575.0 W

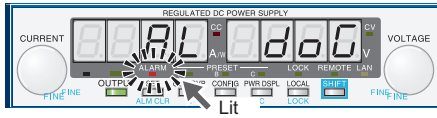
### Communication Monitoring (WATCHDOG)

The watchdog function monitors the SCPI command communication status. Communication is assumed to have stopped if there is no communication within the time period specified by the communication monitoring timer setting (CF17).

This function operates regardless of whether the product is in remote or local (panel control) mode. When using local mode (panel control), set communication monitoring to off in the timer settings. When using remote mode, you can set the timer using a command (OUTP:PROT:WDOG).

You cannot stop communication monitoring with the \*RST, \*RCL, or \*CLS command. In the alarm state, turn off communication monitoring before clearing the alarm.

**Figure 2-26.** Alarm Indication when WATCHDOG has been Activated



## CONFIG Settings

Use the CONFIG settings to set the RMX programmable power supply’s system configuration. You can set and display the following parameters in the CONFIG settings.

**Effect column**

† indicates a parameter that may be affected when the panel settings are reset (CF00), or when a preset memory entry is loaded.

\* indicates a parameter that may be affected when the master unit, the slave unit, or the number of units is changed (CF01).

‡ indicates a parameter that may be affected when the LAN interface settings are reset (CF40:LCi/dEF).

**Note column**

**A** indicates a parameter that is applied immediately.

**B** indicates a parameter that is applied when the RMX programmable power supply is turned on.

**C** indicates a parameter that is applied when CF40 “APPL” is executed.

**Figure 2-27.** CONFIG Setting and Display Examples



**Table 2-3. CONFIG Settings**

Display Switching	Parameter Number	Description	Effect	Note
SYSTEM	CF00 <sup>1</sup>	Resets the panel settings	—	A
	CF01	Master-slave parallel operation parameter	*	B
	CF02 <sup>1</sup>	Power-on status parameter	—	B
	CF03	Method for clearing OHP, FAN, and AC-FAIL alarms	—	B
	CF04 <sup>1</sup>	Memory content display parameter	—	A
	CF05 <sup>1</sup>	CC control using an Vext or Rext	†	A
	CF06 <sup>1</sup>	CV control using an Vext or Rext	†	A
	CF07 <sup>1</sup>	CV/CC control range parameter	—	A
	CF08	Range during voltage and current monitoring	—	A
	CF09 <sup>1</sup>	External control parameter for turning output on and off	† *	A
	CF10 <sup>1</sup>	External control logic parameter for turning output on and off	*	A
	CF11	Bleeder on/off parameter	—	A
	CF12 <sup>1</sup>	Output-on startup state parameter	*	A
	CF13	Detection time of OCP activation	—	A
	CF14 <sup>1</sup>	Current setting limit	† *	A
	CF15 <sup>1</sup>	Voltage setting limit	† *	A
	CF16	Panel display brightness setting	—	A
	CF17	Communication monitor timer setting	—	A
	CF18	Unused	—	—
CF19 <sup>2</sup>	Current and power display on slave units for master-slave parallel operation	—	A	

**Table 2-3. CONFIG Settings (Continued)**

Display Switching	Parameter Number	Description	Effect	Note
Interface	CF20	LAN interface parameter	* † <sup>3</sup>	B
	CF21	Command language parameter	*	B
	CF22	Emulation parameter during remote control	*	B
	CF23	SCPI communication error display parameter	*	A
	CF24	Multichannel (VMCB) domain number parameter	* † <sup>3</sup>	B or C
	CF25	Multichannel (VMCB) channel number	* † <sup>3</sup>	B or C
LAN <sup>4</sup>	CF30	IP address display (1)	*	—
	CF31	IP address display (2)	*	—
	CF32	IP address display (3)	*	—
	CF33	IP address display (4)	*	—
	CF34	MAC address display (1) and (2)	*	—
	CF35	MAC address display (3) and (4)	*	—
	CF36	MAC address display (5) and (6)	*	—
	CF40	Resets (LCI/DEF) or applies (APPL) the LAN settings.	*	A
	CF41	IP address assignment method	* †	B or C
	CF42	Manual IP address setting (1)	* †	B or C
	CF43	Manual IP address setting (2)	* †	B or C
	CF44	Manual IP address setting (3)	* †	B or C
	CF45	Manual IP address setting (4)	* †	B or C
	CF46	IP address subnet mask prefix setting	* †	B or C
CF47	SCPI-RAW protocol TCP port number	* †	B or C	
USB	CF50	VID (vendor ID) display	*	—
	CF51	PID (product ID) display	*	—
RS232C	CF52	RS232C baud rate parameter	*	B

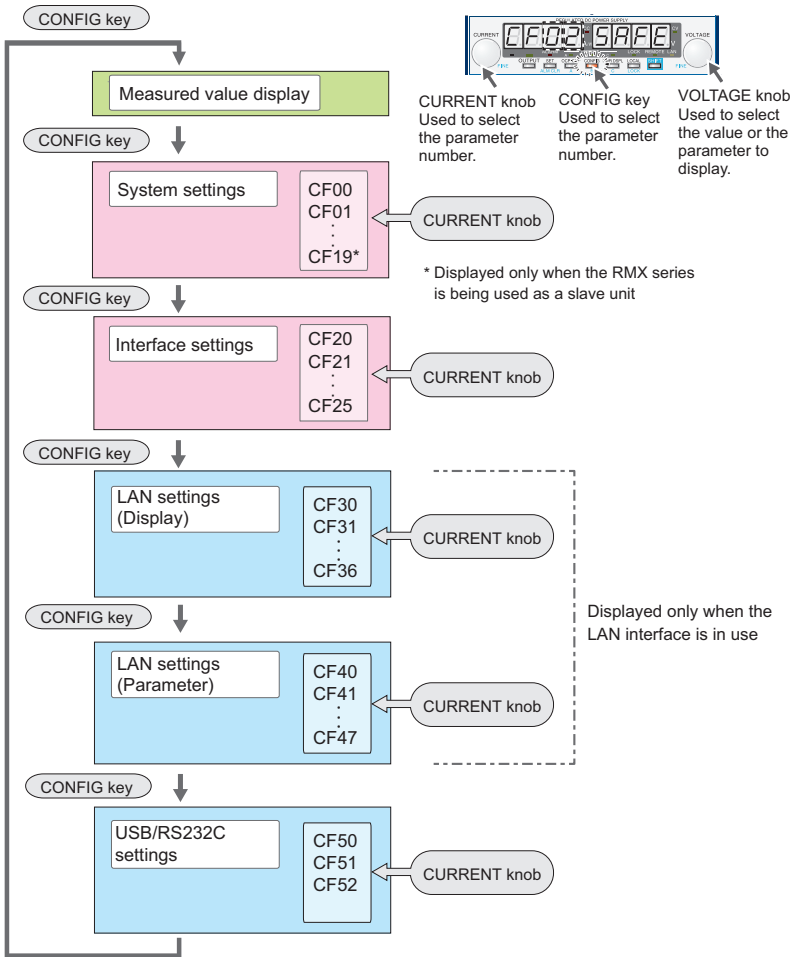
<sup>1</sup> You can only specify this parameter when the RMX programmable power supply is being used as a master unit.

<sup>2</sup> You can only specify this parameter only when the RMX programmable power supply is being used as a slave unit.

<sup>3</sup> This parameter is affected only when the LAN interface settings are reset (CF40: dEF).

<sup>4</sup> This parameter is displayed only when the LAN interface is in use (CF20: on).

**Figure 2-28. Selecting CONFIG Parameters**



**Note** CF00, and CF40 are used to execute operations. CF30 to CF36, CF50, and CF51 are read-only parameters used to display the status of the RMX programmable power supply. You cannot set the values of any of these CONFIG parameters.



**Note** The SET key blinks when you have selected a CONFIG parameter whose setting you must confirm by pressing SET (CF00, and CF40).

## Specifying CF01 to CF36, CF 41 to CF52 CONFIG Settings



**Note** Excludes CF00 (Reset panel settings) and CF40 (Resets or applies LAN interface settings).

Complete the following steps to specify the CONFIG settings.

1. Press CONFIG.

The CONFIG key lights, and the SET key blinks. The ammeter displays the parameter number—CF00. The voltmeter displays the corresponding setting—rSt.

2. Press CONFIG or turn the CURRENT knob to select the number of the parameter that you want to set.

When you press CONFIG, the RMX programmable power supply switches between the parameter ranges in the following order.

CF00 -->CF20 -->CF30 -->CF40 -->CF50 -->measured value display

When you turn the CURRENT knob, the RMX programmable power supply increments through the parameter numbers within the currently selected parameter range.



**Tip** Press CONFIG or turn the CURRENT knob to switch between the parameter numbers. These two methods switch between the parameter numbers differently.

3. Turn the VOLTAGE knob to change the value of the parameter.
4. To specify or display other parameters, repeat steps 2 and 3. To stop specifying CONFIG settings, proceed to step 5.
5. Continue pressing CONFIG until the measured value display appears. Alternatively, press OUTPUT or PWR DSPL. If you are configuring a slave unit, press CONFIG or PWR DSPL.

Some CONFIG parameters will be applied immediately after you set them, some will be applied after you restart the RMX programmable power supply, and some will be applied after you execute CF40 “APPL”.



## Specifying CF00/CF40 CONFIG Settings

- Resetting the panel settings (CF00)
- Resetting or applying the LAN interface settings (CF40)

Complete the following steps to specify the CONFIG settings for CF00 or CF40

1. Press CONFIG once (for CF00) or four times (for CF40).

The CONFIG key lights and the SET key blinks.

If you pressed CONFIG once, the ammeter displays the parameter number—CF00. The voltmeter displays the corresponding setting—rSt. If you pressed CONFIG four times, the ammeter displays the parameter number—CF40. The voltmeter displays the corresponding setting—Lci/DEF/APPL.

2. Press SET, which is blinking.

The CONFIG key lights, and the SET key, the parameter number displayed on the ammeter, and the setting displayed on the voltmeter all blink.

3. Press SET, which is blinking, again.

While the parameter number and the setting are blinking, no new settings will be applied until you press SET.

When setting CF00, the measured value display appears.

When CF40 is set, the LAN LED lights in orange (for about 4 to 5 seconds) while the setting is being confirmed and then turns green when it is complete. Press SET to exit the CONFIG settings. The settings will be applied.

If the LAN LED turns red, set the settings again.

## CONFIG Parameter Details

The CONFIG parameters are explained in detail below.

### CF00 Resets the Panel Settings

This configuration parameter resets all of the settings listed below to their default values. The following settings will be reset. When the settings are reset, the RMX programmable power supply settings take on the same values as they do when an \*RST command is received.

You can only use this parameter when the RMX programmable power supply is being used as a master unit.

- Output voltage
- Output current
- Overvoltage protection
- Overcurrent protection
- Undervoltage limit
- Output on/off at power-on
- Constant current control using an Vext or Rext (CF05)

- Constant voltage control using an Vext or Rext (CF06)
- External control setting for turning output on and off (CF09)
- Voltage and current setting limits (CF15 and CF14)

Value	Parameter Description
rSt	Resets the panel settings

### CF01 Master-slave Parallel Operation Parameter

Sets the total number of units (master unit and slave units) in master-slave parallel operation. Specify “SLAV” for the units that you want to use as slaves. This parameter is applied when you turn the POWER switch off and on.

Changing this setting may affect the settings of the master unit or the slave units that are connected in parallel.

Value	Parameter Description
SLAV	Use the RMX as a slave unit
1 to 4	Set the total number of units (1 to 4; 1 indicates independent operation–factory default setting).

### CF02 Power-on Status Parameter

Sets the condition that the RMX programmable power supply will be in when the power is turned on. This setting is invalid when you are using an external contact to turn the output off. This parameter only applies when you turn the POWER switch off and on.

You can only specify this parameter when the RMX programmable power supply is being used as a master unit.

Value	Parameter Description
SAFE	The settings that were in use immediately before the POWER switch was turned off are used. The output is off (factory default setting).
Auto	The settings that were in use immediately before the POWER switch was turned off are used. This includes whether output was on or off.
ForC	The settings that were in use immediately before the POWER switch was turned off are used. The output is turned on.

### CF03 Method for Clearing OHP, FAN, and AC-FAIL Alarms

Sets the method for clearing alarms when overheat protection (OHP), fan failure protection (FAN), or low AC input protection (AC-FAIL) has been activated. You cannot set this parameter separately for each protection function.

When you select “Auto,” if the overheat protection function (OHP) has been activated, output will turn on again automatically when the internal temperature drops to a normal level. However, if you do not fix the problem that caused the alarm to occur, the alarm will occur again, which will force you to clear the alarm again. The overheat protection devices have long service lives (approximately 100000 uses), but if they reach the end of their service lives, they will stop operating. To maintain the performance of the RMX programmable power supply for a long time, we request that you fully understand the Auto feature and only use it when necessary.

Value	Parameter Description
SAFE	After the problem that caused an alarm to occur is fixed, the output is not turned on automatically (factory default setting).
Auto	After the problem that caused an alarm to occur is fixed, the output is turned on automatically.

### CF04 Memory Content Display Parameter

Sets whether to display the saved contents in the preset memory before recalling them. You can use this CONFIG parameter if you forget what settings have been saved to a preset memory entry or if you want to view the saved settings.

You can only specify this parameter when the RMX programmable power supply is being used as a master unit.

Value	Parameter Description
oFF	The saved contents of preset memory will be recalled without displaying them.
on	The saved contents of preset memory will be displayed and then recalled after confirmation (factory default setting).

### CF05 CC Control Using a Vext or Rext

Selects whether constant current will be controlled by an external voltage (Vext) or an external resistance (Rext) or an external resistance (Rext) via the J1 connector. This is set to “oFF” when the panel settings are reset (CF00) and when a preset memory entry is recalled.

You can only specify this parameter when the RMX programmable power supply is being used as a master unit.

Value	Parameter Description
oFF	External control will not be performed (factory default setting).
on	External control will be performed.

### CF06 CV Control Using a Vext or Rext

Selects whether constant voltage will be controlled by an external voltage (Vext) or an external resistance (Rext) via the J1 connector. This is set to “oFF” when the panel settings are reset (CF00) and when a preset memory entry is recalled.

You can only specify this parameter when the RMX programmable power supply is being used as a master unit.

Value	Parameter Description
oFF	External control will not be performed (factory default setting).
on	External control will be performed.

### CF07 CV/CC Control Range Parameter

Selects the range that is used when controlling constant current and constant voltage with an external voltage or an external resistance (the J1 connector).

You can only specify this parameter when the RMX programmable power supply is being used as a master unit.

Value	Parameter Description
Lo	0 to 5 V (factory default setting)
hi	0 to 10 V

### CF08 Range During Voltage and Current Monitoring

Selects the range during voltage and current monitoring.

Value	Parameter Description
Lo	0 to 5 V (factory default setting)
hi	0 to 10 V

### CF09 External Control Parameter for Turning Output On and Off

Selects whether an external contact (pin 18 on the J1 connector) will be used to turn output on and off. This is set to “oFF” when the panel settings are reset (CF00) and when a preset memory entry is recalled.

You can only specify this parameter when the RMX programmable power supply is being used as a master unit.

Value	Parameter Description
oFF	External control is not performed (factory default setting).
on	External control is performed.

### CF10 External Control Logic Level for Turning Output On and Off

Sets the logic level used when an external contact (pin 18 on the J1 connector) is being used to turn output on and off.

You can only specify this parameter when the RMX programmable power supply is being used as a master unit.

Value	Parameter Description
Lo	Output is turned on when a LOW signal (0 to 0.5 V) or short-circuit is received (factory default setting).
hi	Output is turned on when a HIGH signal (4.5 to 5 V) or open-circuit is received.

### CF11 Bleeder On or Off

Turns the bleeder circuit on and off. You can turn the bleeder circuit off when you don’t want the electric charge stored in the output capacitance of the supply to sink into the internal bleeder circuit, such as when you are charging a battery.

Even when the output terminal is off (open) or when the set voltage is 0 V, if you turn the bleeder off, a voltage as large as a few hundred millivolts may appear at the output terminal.

Depending on whether the bleeder circuit is enabled, the fall time of the output voltage and the amount of current sunk into the power supply will vary when an external load is connected.

When using master-slave parallel operation or series operation, use the same settings on all connected units.

Value	Parameter Description
oFF	The bleeder circuit is turned off.
on	The bleeder circuit is turned on (factory default setting).

### CF12 Output-on Startup State Parameter

Sets the operation mode to be prioritized when the output is turned on. Prioritizing the operation mode appropriately can prevent unwanted output overshoots at power-up. When used as a slave device, CC is automatically prioritized. To use the RMX programmable power supply as a standalone unit or master unit after using it as a slave unit, set the operation mode that you want to use. If you do not set the operation mode, CC will continue to be prioritized.

You can only specify this parameter when the RMX programmable power supply is being used as a master unit.

Value	Parameter Description
CC	CC (constant current) is prioritized.
CV	CV (constant voltage) is prioritized (factory default setting).

### CF13 Detection Time of OCP Activation

Set the time when the overcurrent protection (OCP) is activated after an overcurrent is detected. Set this in 100 ms steps.

Value	Parameter Description
0	0 ms (factory default setting).
100 to 2000	100 to 2000 ms

### CF14 Current Setting Limit

Set whether to limit the set output current so that its value cannot exceed the set overcurrent protection (approximately 95% of the OCP trip point). When this parameter is set to "oFF" and you set it to "on" when the OCP is lower than the current setpoint, the value of the current setpoint is maintained and the OCP value will automatically be increased to be 105% of the current setpoint. The parameter will also be changed if the output is on.

This is set to "on" when the panel settings are reset (CF00) and when a preset memory entry is recalled.

You can only specify this parameter when the RMX programmable power supply is being used as a master unit.

Value	Parameter Description
oFF	The setting is not limited.
on	The setting is limited (factory default setting).

### CF15 Voltage Setting Limit

Set whether to limit the set output voltage so that its value cannot exceed the set overvoltage protection (approximately 95% of the OVP trip point) and cannot be set lower than the set undervoltage limit. When this parameter is set to "oFF" and you set it to "on" when the OVP is lower than the voltage setpoint, the value of the voltage setpoint is maintained and the OVP value will automatically be increased to be 105% of the voltage setpoint. In addition, the set UVL will be changed to match the voltage setpoint. The parameter will also be changed if the output is on.

This is set to "on" when the panel settings are reset (CF00) and when a preset memory entry is recalled.

You can only specify this parameter when the RMX programmable power supply is being used as a master unit.

Value	Parameter Description
oFF	The setting is not limited.
on	The setting is limited (factory default setting).

### CF16 Panel Display Brightness Setting

Adjusts the panel display brightness. The larger the number, the brighter the display. Even if you specify the same number, the brightness may differ between individual products.

The brightness is not proportional to the setting.

Value	Parameter Description
1 to 7	Screen brightness (factory default setting: 7).

### CF17 Communication Monitor Timer Setting

Sets the interval for monitoring SCPI command communication. The communication monitoring function operates regardless of whether the product is in remote or local (panel control) mode. If this parameter is not set to "oFF" and the specified time expires before any the device receives any SCPI commands, the Communication Monitoring (WATCHDOG) alarm will trigger.

When using local mode (panel control), be sure to specify oFF.

Value	Parameter Description
oFF	Communication monitor timer is set to off (factory default setting).
1 to 3000	1 s, 3 s, 10s, 30s, 100s, 300s, 1000s, 3000s

**CF18 Unused**

Value	Parameter Description
—	Unused

**CF19 Current and Power Display on Slave Units for Master-slave Parallel Operation**

Sets whether the current or power on slave units is displayed during master-slave parallel operation. You can display and specify this parameter only when the RMX programmable power supply is being used as a slave unit.

If this parameter is set so that the current or power on slave units is not displayed, the ammeter displays”----.”

Value	Parameter Description
oFF	The current or power of slave units is not displayed (factory default setting).
on	The current or power of slave units is displayed.

**CF20 LAN Interface Parameter**

Sets whether the LAN interface will be used. By setting it to “oFF,” you can disable the LAN interface function even when a LAN cable is connected. You cannot set the LAN CONFIG settings while this parameter is turned off.

Even when this is set to “on,” if the command language is set to legacy (CF21: LGCy), you cannot use the LAN interface.

This parameter is applied when you turn the POWER switch off and on.

Value	Parameter Description
oFF	The LAN interface will not be used.
on	The LAN interface will be used (factory default setting).



### CF21 Command Language Parameter

Selects the command language that is used in remote control messages. For the LAN interface to function, this parameter must be set to "SCPi."

This parameter is applied when you turn the POWER switch off and on.

Value	Parameter Description
SCPi	The SCPi language will be used (factory default setting).
LGCy	Legacy languages will be used.

### CF22 Emulation Parameter During Remote Control

Selects the emulation that is used during remote control. If you have set the command language to legacy languages, you can only select "GEN" or "PAG."

This parameter is applied when you turn the POWER switch off and on.

Value	Parameter Description
nonE	Remote control is performed using the RMX programmable power supply's commands made by National Instruments (factory default setting).
5700	Remote control is performed using the N5700/N8700 commands made by Agilent Technologies.
GEN	Remote control is performed using the Genesys series commands made by TDKLambda.
PAG	Remote control is performed using the PAG series commands made by Kikusui.
dCS	Remote control is performed using the DCS series commands made by Sorensen.

### CF23 SCPI Communication Error Display Parameter

Selects whether to display communication errors. The errors are only displayed when you are using the SCPI language.

Value	Parameter Description
oFF	SCPI communication errors are not displayed (factory default setting).
on	SCPI communication errors are displayed.

### CF24 Multichannel (VMCB) Domain Number Parameter

Set the multichannel domain number. RMX models that have the same domain number perform multichannel operations. If you do not want to use the multichannel function, set this to 0 (this is the factory default setting).

If 5700 or DCS emulation is selected, you cannot use multichannel. This parameter is applied when you turn the POWER switch off and on or when you execute CF34.

Value	Parameter Description
0	The multichannel function is not used (factory default setting).
1 to 254	The domain number when the multichannel function is used.

### CF25 Multichannel (VMCB) Channel Number

Set the multichannel channel number. Specify a unique number on the network. If you do not want to use the multichannel function, set this to 0 (this is the factory default setting).

If 5700 or DCS emulation is selected, you cannot use multichannel. This parameter is applied when you turn the POWER switch off and on or when you execute CF34.

Value	Parameter Description
0	The RMX is used as a master unit on the multichannel network (factory default setting).
1 to 30	1 to 30 The RMX is used as a slave unit with this channel number on the multichannel network.

### CF30 to CF33 IP Address Display

These parameters display the set IP addresses. These parameters are only displayed when you are using the LAN interface.

To set a fixed IP address use CONFIG parameters CF42 to CF45 and then apply the LAN settings with CF40. You can also set a fixed IP address when you access the power supply through a web browser. When you access the power supply through a web browser, do so under conditions in which a DHCP server or AUTO IP can be used.

Parameter Number	Display	Description
CF30	0 to 255	Displays the first IP address number
CF31	0 to 255	Displays the second IP address number

Parameter Number	Display	Description
CF32	0 to 255	Displays the third IP address number
CF33	0 to 255	Displays the fourth IP address number

### CF34 to CF36 MAC Address Display

These parameters display the set MAC address. The MAC address is just displayed; it cannot be set from the panel. To set a fixed MAC address, access the RMX programmable power supply through a Web browser. When you access the RMX programmable power supply through a Web browser, do so under conditions in which a DHCP server or AUTO IP can be used. By default, the MAC address is set to 00.80.2F.11.xx.xx (where x is a hexadecimal number between 0 and F).

Parameter Number	Display	Description
CF34	00.80	Displays the first and second MAC address numbers (read only).
CF35	2F.11	Displays the third and fourth MAC address numbers (read only).
CF36	xx.xx	Displays the fifth and sixth MAC address numbers (read only).

### CF40 Resetting (LCI/DEF) or applying (APPL) the LAN Interface Settings

Sets whether to reset or apply the LAN interface settings. This parameter is displayed and can be set only when the LAN interface is in use.

Value	Parameter Description
LCI	The LAN interface settings will be reset to their factory default settings.
dEF	Resets the LAN interface and network settings (factory default values).
APPL	Applies the CONFIG settings related to the LAN interface.

### CF41 IP Address Assignment Method

Sets the IP address assignment method. This parameter is displayed and can be set only when the LAN interface is in use.

Set whether to use (on: 1) or not use (off: 0) the following: DHCP server, AUTO IP function (automatic assignment), and MANUAL IP assignment.

If an IP address is not assigned through a DHCP server, AUTO IP is used.

To use the MANUAL IP function, set the DHCP server and AUTO IP function to off. The address that is assigned by the AUTO IP function is 169.254.x.x (where x is a number between 0 and 254).

This parameter is applied when you turn the POWER switch off and on or when you execute APPL with CF40.

If the LAN interface settings are reset (CF40: LCI/dEF) this is set to (110).

Value/Display	Parameter Description
--	DHCP:OFF, AUTO IP: OFF, MANUAL IP: ON
--	DHCP:OFF, AUTO IP: ON, MANUAL IP: OFF
--	DHCP:OFF, AUTO IP: ON, MANUAL IP: ON
--	DHCP:ON, AUTO IP: OFF, MANUAL IP: OFF
--	DHCP:ON, AUTO IP: OFF, MANUAL IP: ON
--	DHCP:ON, AUTO IP: ON, MANUAL IP: OFF (factory default setting)
---	DHCP:ON, AUTO IP: ON, MANUAL IP: ON

### CF42 to CF45 Manual IP Address Setting (Manual IP Function)

If you do not want to or cannot use a DHCP server or if you do not want to or cannot use the AUTO IP function, set the IP address manually. This parameter is displayed and can be set only when the LAN interface is in use.

These parameters are applied when you turn the POWER switch off and on when you execute APPL with CF40.

Parameter Number	Value	Description
CF42	0 to 255	Sets the first IP address number.
CF43	0 to 255	Sets the second IP address number.
CF44	0 to 255	Sets the third IP address number.
CF45	0 to 255	Sets the fourth IP address number.

### CF46 IP Address Subnet Mask Prefix Setting

If you want to set the IP address manually (MANUAL IP function), set the subnet mask prefix. This parameter is displayed and can be set only when the LAN interface is in use.

This parameter is applied when you turn the POWER switch off and on or when you execute APPL with CF40.

Parameter Number	Value	Description
CF46	16 to 31	Sets the subnet mask prefix.
Examples:	Display example when “16” is set	255.255.0.0
	Display example when “24” is set	255.255.255.0
	Display example when “31” is set	255.255.255.254

### CF47 SCPI-RAW Protocol TCP Port Number Setting

Set the TCP port number of the SCPI-RAW protocol for when the LAN interface is in use.

This parameter is applied when you turn the POWER switch off and on or when you execute CF40. TCP port number 4880 cannot be used.

Value	Parameter Description
4000 to 9999 (except 4880, 5024, and 5044)	TCP port number (factory default setting: 5025)

### CF50 Vendor ID Display

Displays the USB Vendor ID.

Display	Description
3923	0x3923

### CF51 Product ID Display

Displays the USB Product ID.

Display	Description
78A3	RMX4121 0x78A3
78A4	RMX4122 0x78A4
78A6	RMX4124 0x78A6
78A7	RMX4125 0x78A7
78A8	RMX4126 0x78A8
78A9	RMX4127 0x78A9

### CF52 RS232C Baud Rate Setting

Sets the RS232C baud rate. This parameter is applied when you restart the RMX programmable power supply.

Value	Parameter Description
1.2	1200 bps
2.4	2400 bps
4.8	4800 bps
9.6	9600 bps
19.2	19200 bps (factory default setting)
38.4	38400 bps
57.6	57600 bps
115.2	115200 bps

# Preset Memory Function

---

RMX programmable power supplies have a preset memory function that allow users to store three sets of the following settings: voltage setpoint, current setpoint, and OVP/OCP/UVL trip points. These settings can be recalled from the preset memory slots whenever they are needed.

To save the current settings into a preset memory slot, hold down the shift key and the key for the slot you'd like to save the settings to (A, B, or C) until the key's LED illuminates.

To recall a set of saved settings, hold the shift key and press the key for the slot you'd like to recall (A, B, or C). The settings will go into effect the moment you press the memory slot key.

The recalling will be effective at the moment when you select the preset memory. To save the present settings, you need to keep holding down the keys (SHIFT+A, B, or C).

## Saving Settings to Preset Memory

1. Press SET.

The SET key will light up, and the present voltage and current settings will be displayed on the panel.

2. While viewing the values displayed on the panel, use the VOLTAGE and CURRENT knobs to program the setpoint values you'd like to write to memory.

3. Press OCP•OVP

The OCP•OVP key will light up, and the OVP trip point and OCP trip point will be displayed in the display area.

4. While viewing the values displayed on the panel, use the VOLTAGE and CURRENT knobs to program the OVP and OCP trip points you'd like to write to memory.

5. Press OCP•OVP again. The present UVL trip point is displayed.

6. While viewing the value displayed on the panel, turn the VOLTAGE knob to program the UVL trip point you want to write to memory.

7. Press SHIFT+ the memory key (A, B, or C) to which you want to save the settings. Hold the keys down until their LEDs turn on.

The PRESET A, PRESET B, or PRESET C LED in the display area—whichever one corresponds to the memory entry that you selected—lights to indicate that the preset memory entry has been saved.

You can save preset memory entries when the output is on and the measured value display is being shown (the SET key LED is off). After you save a preset memory entry, press SET to view the preset memory values.

## Recalling Preset Memory Entries

You can recall preset memory entries from the measured value display (when the SET key LED is off) and from the setting display (when the SET key LED is lit). If the output is on, the values in the preset memory entry are applied to the output the moment that the preset memory entry is recalled.

There are two methods to recall a preset memory entry. One method is to display the saved contents for confirmation and then recall (CF04: on). The other is to recall immediately without displaying the contents (CF04: oFF).

When you recall a preset memory entry, the following items are set to their factory default settings.

- Constant current control using an Vext or Rext (CF05: oFF)
- Constant voltage control using an Vext or Rext (CF06: oFF)
- Output on/off control using an external contact (CF09: oFF)
- Current setting limit (CF14: on)
- Voltage setting limit (CF15: on)

Complete the following steps to display the saved contents for confirmation and recall.

1. Press SHIFT+ the memory key (A, B, or C) from which you want to recall the preset memory entry.

The SET LED and the contents (voltage and current) of the loaded preset memory that are shown in the display area blink. If you press another memory key, the contents of the corresponding memory appear blinking.



**Note** This is convenient when you want to view the contents that have been saved to memory.

2. Check the displayed settings, and then press SET.

The SET LED and the LED that corresponds to the loaded preset memory entry both light, and the set voltage and current are displayed on the panel.



**Note** Press OCP•OVP, CONFIG, or PWR DSPL to cancel the recall operation.

Complete the following steps to recall without displaying the saved contents.

1. Use the CONFIG settings to set the RMX programmable power supply to hide the saved contents of preset memory entries (CF04: oFF).



**Note** This is convenient when you know the contents that have been saved to memory.

2. While holding down the SHIFT key, press the appropriate memory key (A, B, or C).

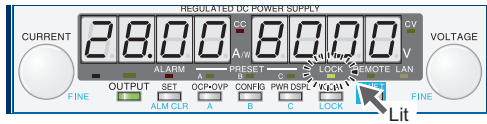
The LED that corresponds to the preset memory entry that you have loaded (PRESET A, B, or C) lights.



## Locking Panel Operations (Key Lock)

The RMX programmable power supply key lock function prevents you from accidentally changing the settings.

**Figure 2-29.** Key Lock Display Example



When the keys are locked (when the LOCK LED is lit), only the OUTPUT key is valid.

1. Configure all the settings, such as the output voltage and output current, as necessary.
2. Hold down LOCK (SHIFT+LOCAL) until the LOCK LED in the display area lights.

When the LOCK LED lights, the keys are locked.

To unlock the keys, hold down LOCK again (SHIFT+LOCAL) until the LOCK LED turns off.

## Bleeder On/Off Feature

You can turn the bleeder circuit on and off. Turn the bleeder circuit off when you do not want the internal bleeder circuit to sink output current. When you connect a battery, you can prevent excessive electrical discharges by turning the bleeder circuit off.

When using master-slave parallel operation or series operation, use the same bleeder circuit settings on all connected units.

Depending on whether the bleeder circuit is on or off, the sink current and the fall time of output voltage when an external voltage source is connected will vary. The sink current or fall time indicated here is a standard value.



**Caution** Risk of electric shock. Set the bleeder on/off setting to “on” before you touch the output terminals. Even if you turn the output off or turn the POWER switch off, if the bleeder on/off setting is set to “oFF” the voltage that was present when the output was on will remain at the output terminals.

**Table 2-4.** Sink Current From an External Source when Bleeder is On/Off

Model	Bleeder Circuit	Sink Current					
		5 $V_{OUT}^1$	10 $V_{OUT}$	15 $V_{OUT}$	20 $V_{OUT}$	25 $V_{OUT}$	30 $V_{OUT}$
RMX-4120/ RMX-4124	ON	704 mA	667 mA	630 mA	593 mA	556 mA	519 mA
	OFF	0.2 mA	0.4 mA	0.6 mA	0.8 mA	1.0 mA	1.2 mA

<sup>1</sup> Even when the bleeder is on, the sink current decreases gradually at output terminal voltages lower than this voltage. If the output terminal voltage is near 0 V, hardly any current will be sunk even when the bleeder is on.



**Note**  $V_{OUT}$  = Output terminal voltage.

**Table 2-5.** Sink Current From an External Source when Bleeder is On/Off

Model	Bleeder Circuit	Sink Current					
		10 $V_{OUT}^1$	20 $V_{OUT}$	50 $V_{OUT}$	100 $V_{OUT}$	200 $V_{OUT}$	230 $V_{OUT}$
RMX-4122	ON	746 mA	549 mA	307 mA	177 mA	96 mA	84 mA
	OFF	0.2 mA	0.3 mA	0.7 mA	1.3 mA	2.5 mA	2.9 mA
RMX-4126	ON	1097 mA	808 mA	451 mA	260 mA	140 mA	123 mA
	OFF	0.3 mA	0.5 mA	1.3 mA	2.5 mA	5.0 mA	5.8 mA

<sup>1</sup> Even when the bleeder is on, the sink current decreases gradually at output terminal voltages lower than this voltage. If the output terminal voltage is near 0 V, hardly any current will be sunk even when the bleeder is on.



**Note**  $V_{OUT}$  = Output terminal voltage.

**Table 2-6.** Sink Current From an External Source when Bleeder is On/Off

Model	Bleeder Circuit	Sink Current								
		5 V <sub>OUT</sub> <sup>1</sup>	10 V <sub>OUT</sub>	20 V <sub>OUT</sub>	30 V <sub>OUT</sub>	40 V <sub>OUT</sub>	50 V <sub>OUT</sub>	60 V <sub>OUT</sub>	70 V <sub>OUT</sub>	80 V <sub>OUT</sub>
RMX-4121/ RMX-4125	ON	704 mA	667 mA	593 mA	519 mA	444 mA	370 mA	296 mA	222 mA	148 mA
	OFF	0.2 mA	0.3 mA	0.5 mA	0.7 mA	0.9 mA	1.1 mA	1.3 mA	1.5 mA	1.7 mA

<sup>1</sup> Even when the bleeder is on, the sink current decreases gradually at output terminal voltages lower than this voltage. If the output terminal voltage is near 0 V, hardly any current will be sunk even when the bleeder is on.



**Note** V<sub>OUT</sub> = Output terminal voltage.

**Table 2-7.** Sink Current From an External Source when Bleeder is On/Off

Model	Bleeder Circuit	Sink Current								
		20 V <sub>OUT</sub> <sup>1</sup>	50 V <sub>OUT</sub>	100 V <sub>OUT</sub>	200 V <sub>OUT</sub>	300 V <sub>OUT</sub>	400 V <sub>OUT</sub>	500 V <sub>OUT</sub>	600 V <sub>OUT</sub>	650 V <sub>OUT</sub>
RMX-4123/ RMX-4127	ON	463 mA	325 mA	217 mA	130 mA	93 mA	73 mA	59 mA	50 mA	47 mA
	OFF	0.2 mA	0.5 mA	0.9 mA	1.7 mA	2.5 mA	3.4 mA	4.2 mA	5.0 mA	5.5 mA

<sup>1</sup> Even when the bleeder is on, the sink current decreases gradually at output terminal voltages lower than this voltage. If the output terminal voltage is near 0 V, hardly any current will be sunk even when the bleeder is on.



**Note** V<sub>OUT</sub> = Output terminal voltage.

## Fall Time

This is the time period for the rated output voltage to fall from 90% to 10% when the output is changed from on to off under no load conditions.

**Table 2-8.** Fall Time of the Output Voltage when the Bleeder is Off

<b>Model</b>	<b>Fall Time</b>
RMX-4120	310 seconds
RMX-4121	280 seconds
RMX-4122	110 seconds
RMX-4123	70 seconds
RMX-4124	490 seconds
RMX-4125	460 seconds
RMX-4126	130 seconds
RMX-4127	100 seconds

## Switching from Remote Mode to Local Mode

---

When the RMX programmable power supply is being controlled remotely, the REMOTE LED in the display area lights.

To switch the RMX programmable power supply to local mode from the front panel, press LOCAL.

# Factory Default Settings (Initialization)

If you hold down SHIFT+LOCAL while you turn the POWER switch on, the RMX programmable power supply will be reset to the factory default settings.

The factory default settings are shown in the following table.

**Table 2-9. Basic Settings**

Basic Item	Parameter Description
Output Voltage	0 V
Output Current	105% of the rated output current
OVP (Overvoltage Protection)	112% of the rated output current
OCP (Overcurrent Protection)	112% of the rated output current
UVL (Undervoltage Limit)	0 V

**Table 2-10. CONFIG Settings**

Parameter Number	CONFIG Parameter	Parameter Description
CF01	Master-slave parallel operation parameter	1 (independent operation)
CF02 <sup>1</sup>	Power-on status parameter	SAFE (panel settings that were in use the last time the power was turned off)
CF03	Method for clearing OHP, FAN, and AC-FAIL alarms	SAFE (do not clear the alarm automatically)
CF04 <sup>1</sup>	Memory content display parameter	ON (displayed)
CF05 <sup>1</sup>	CC control using an Vext or Rext	OFF
CF06 <sup>1</sup>	CV control using an Vext or Rext	OFF
CF07 <sup>1</sup>	CV/CC control range parameter	LO (0 to 5 V)
CF08	Range during voltage and current monitoring	LO (0 to 5 V)
CF09 <sup>1</sup>	External control parameter for turning output on and off	OFF
CF10 <sup>1</sup>	External control logic parameter for turning output on and off	LO (a LOW signal turns output on) <sup>2</sup>
CF11	Bleeder on/off parameter	ON (bleeder circuit is on)

**Table 2-10. CONFIG Settings (Continued)**

<b>Parameter Number</b>	<b>CONFIG Parameter</b>	<b>Parameter Description</b>
CF12 <sup>1</sup>	Output-on startup state parameter	CV (CV is prioritized)
CF13	Detection time of OCP activation	0 ms
CF14 <sup>1</sup>	Current setting limit	ON (the setting is limited)
CF15 <sup>1</sup>	Voltage setting limit	ON (the setting is limited)
CF16	Panel display brightness setting	7
CF17	Communication monitor timer setting	OFF (Communication monitoring timer off)
CF18	Unused	—
CF19 <sup>3</sup>	Display setting on slave units for master-slave parallel operation	OFF (not displayed on slave units)
CF20	LAN interface parameter	LAN (the LAN interface will be used)
CF21	Command language parameter	SCPI
CF22	Emulation parameter during remote control	NONE (RMX programmable power supply commands)
CF23	SCPI communication error display parameter	OFF (not displayed)
CF24	Multichannel (VMCB) domain number	0 (the multichannel function is not used)
CF25	Multichannel (VMCB) channel number	0 (the RMX programmable power supply is used as a master unit on the multichannel network)
CF41	IP address assignment method	DHCP: ON AUTO IP: ON MANUAL IP: OFF
CF47	SCPI-RAW protocol TCP port number	5025
CF52	RS232C baud rate parameter	19.2 (kbit/s)

<sup>1</sup> You can only specify this parameter when the RMX programmable power supply is being used as a master unit.  
<sup>2</sup> 0 to 0.5 V or shorted.  
<sup>3</sup> You can only specify this parameter when the RMX programmable power supply is being used as a slave unit.

---

# External Control

This chapter explains external control and external monitoring using the J1 connector.

## Overview

---

You can use the J1 connector on the rear panel of the RMX programmable power supply to perform the following types of external control.

- Output voltage control (Controlled using an external voltage or external resistance)
- Output current control (Controlled using an external voltage or external resistance)
- Turning output on and off using an external contact
- Output shutdown control using an external contact
- Clearing alarms using an external contact
- Monitoring operation modes

## About the J1 Connector

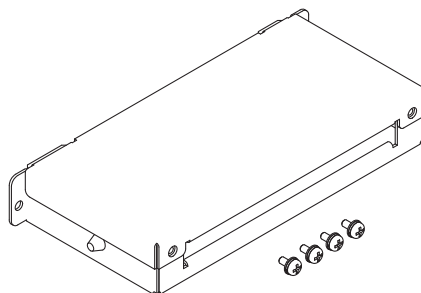
---

Use the included J1 connector plug kit for connecting to the J1 connector. RMX programmable power supplies are supplied with a connector cover that fits over the entire sensing, J1, and J2 connectors. For safety reasons, be sure to attach the connector cover when you use the RMX programmable power supply.

---

**Figure 3-1.** Connector Cover

---



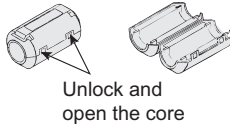
Plug kit 749809-9 DB25 is included for connecting to the J1 connector.

## Attaching the J1 Cable Core

To connect to the J1 connector, requires a core on the cable for connection. The core is not included. Use an appropriate core.

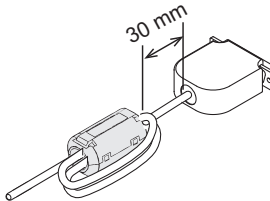
1. Unlock the snap-on core and open to split.

**Figure 3-2. Unlocking the Snap-on Core**



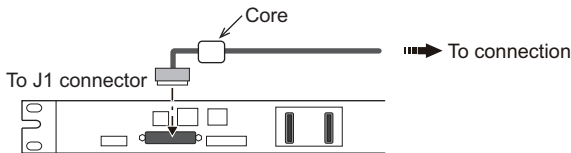
2. Wrap the cable twice around either half of the open core. Wrap the wire so that the distance between the core and the J1 connector is within 30 mm.

**Figure 3-3. Wrapping the Cable Around the Open Core**



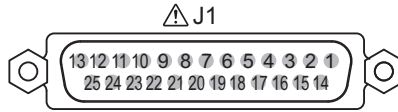
3. Close the core keeping the J1 cable from being wedged in between. Check that the core is securely locked.

**Figure 3-4. Unlocking the Snap-on Core**





**Figure 3-5. J1 Connector Pinout**



**Table 3-1. J1 Connector Signals**

Pin	Signal Name	Description
1	PRL ON COM	Common for pin 16.
2	N.C.	Not connected.
3	N.C.	Not connected.
4	N.C.	Not connected.
5	ALM CLR	Alarm clear terminal Alarms are cleared when a LOW (0 to 5 V) or short-circuit is applied to this terminal.
6	SHUT DOWN	Output shutdown control terminal. The output is turned off when a LOW (0 to 0.5 V) or short-circuit is applied to this terminal.
7	PRL IN-	Negative input terminal for master-slave parallel operation.
8	PRL IN+	Positive input terminal for master-slave parallel operation.
9	PRL COMP IN	Correction signal input terminal for master-slave parallel operation.
10	A COM	External signal common for pins 5 to 9, 11 to 13, 20 to 22, 24, and 25. During remote sensing, this is the negative electrode (-S) of sensing input. When remote sensing is not being performed, this is connected to the negative output.
11	PRL OUT+	Positive electrode output terminal for master-slave parallel operation.
12	PRL COMP OUT	Correction signal output terminal for master-slave parallel operation.
13	I SUM	Current signal terminal for master-slave parallel operation.
14	N.C.	Not connected.
15	N.C.	Not connected.
16	PRL ON	On during master-slave parallel operation (output through an open-collector photocoupler). <sup>1</sup>
17	N.C.	Not connected.

**Table 3-1. J1 Connector Signals (Continued)**

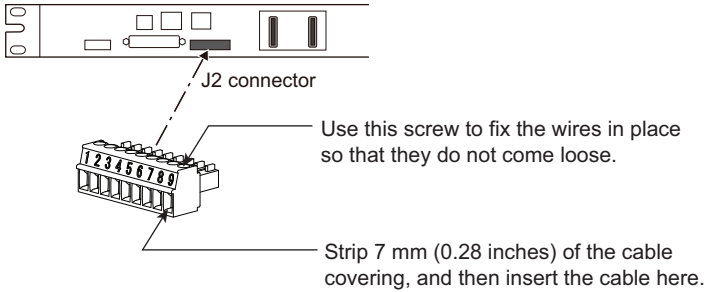
Pin	Signal Name	Description
18	OUT ON/OFF CONT	Output on/off terminal. On when set to LOW (0 to 0.5 V) or shorted (CF10: Lo); Off when set to HIGH (4.5 or 5 V) or open (CF10: Lo) On when set to HIGH (4.5 to 5 V) or open (CF10: Hi); Off when set to LOW (0 or 0.5 V) or shorted (CF10: Hi).
19	A COM	External signal common for pins 5 to 9, 11 to 13, 20 to 22, 24, and 25. During remote sensing, this is the negative electrode (-S) of sensing input. When remote sensing is not being performed, this is connected to the negative output.
20	REF OUT	External resistance control terminal; 5.25 V (CF07: Lo) or 10.5 V (CF07: Hi). The maximum output current 2.5 mA.
21	I PGM	Terminal used to control the output current with an external voltage or external resistance. 0 to 5 V; 0 to 100% of the rated output current (CF07: Lo). 0 to 10 V; 0 to 100% of the rated output current (CF07: Hi).
22	V PGM	Terminal used to control the output voltage with an external voltage or external resistance. 0 to 5 V; 0 to 100% of the rated output voltage (CF07: Lo). 0 to 10 V; 0 to 100% of the rated output voltage (CF07: Hi).
23	A COM	External signal common for pins 5 to 9, 11 to 13, 20 to 22, 24, and 25. During remote sensing, this is the negative electrode (-S) of sensing input. When remote sensing is not being performed, this is connected to the negative output.
24	I MON	Output current monitor. 0 to 100% of the rated output current is generated as a voltage between 0 and 5 V (CF08: Lo) or a voltage between 0 and 10 V (CF08: Hi).
25	V MON	Output voltage monitor. 0 to 100% of the rated output voltage is generated as a voltage between 0 and 5 V (CF08: Lo) or a voltage between 0 and 10 V (CF08: Hi).
<sup>1</sup> Open collector output: Maximum voltage of 30 V and maximum current of 8 mA.		

# About the J2 Connector

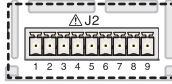
The J2 connector can be split into two parts: the socket and the detachable plug. The plug is attached to the J2 socket when the RMX programmable power supply ships from the factory. If you damage or lose the detachable plug, contact National Instruments for a replacement.

To minimize the influence of noise, NI recommends using shielded twisted pair wires to make connections.

**Figure 3-6. J2 Connector**



**Figure 3-7. J2 Connector Pinout**



**Table 3-2. J2 Connector Signals**

Pin	Signal	Description
1	CV STATUS	On when the RMX programmable power supply is in CV mode. (open-collector output from a photocoupler) <sup>1</sup>
2	CC STATUS	On when the RMX programmable power supply is in CC mode. (open-collector output from a photocoupler) <sup>1</sup>
3	ALM STATUS	On when a protection function (OVP/OVP2/ OCP/ OHP/ OHP2/ FAN/ SEN/ACAC-FAIL) is activated. (output through an open-collector photocoupler) <sup>1</sup>
4	PWR ON STATUS	Outputs a low level signal when power is turned on (output through an open-collector photocoupler) <sup>1</sup>
5	OUT ON STATUS	On when output is on (output through an open-collector photocoupler) <sup>1</sup>
6 to 9	STATUS COM	Status signal common for pins 1 to 5 <sup>2</sup> .
<p>The above signal output circuit is protected with reinforced insulation from the MAINS.</p> <p><sup>1</sup> Open collector output: Maximum voltage of 30 V and maximum current of 8 mA.</p> <p><sup>2</sup> That status common is floating (isolation voltage of 60 V or less), it is isolated from the control circuit.</p>		

# Output Terminal Insulation

---



**Caution** Risk of electric shock. For safety reasons, even if the output terminal is grounded, secure reinforced or double insulation with a capacity greater than or equal to the isolation voltage of the RMX programmable power supply for the output terminals (including sensing terminals) and load cables. Refer to Appendix A, *Specifications*, for the isolation voltage of your model.

If cables with sufficient voltage rating cannot be obtained, use insulation tubes to secure reinforced or double insulation with a capacity greater than or equal to the isolation voltage of the RMX programmable power supply.

Confirm the voltage between any output terminal and ground is lower than the isolation voltage of the RMX power supply.

The signal cable may burn out. If the RMX programmable power supply is to be controlled through an external voltage ( $V_{ext}$ ), do not ground the external voltage (leave it floating).

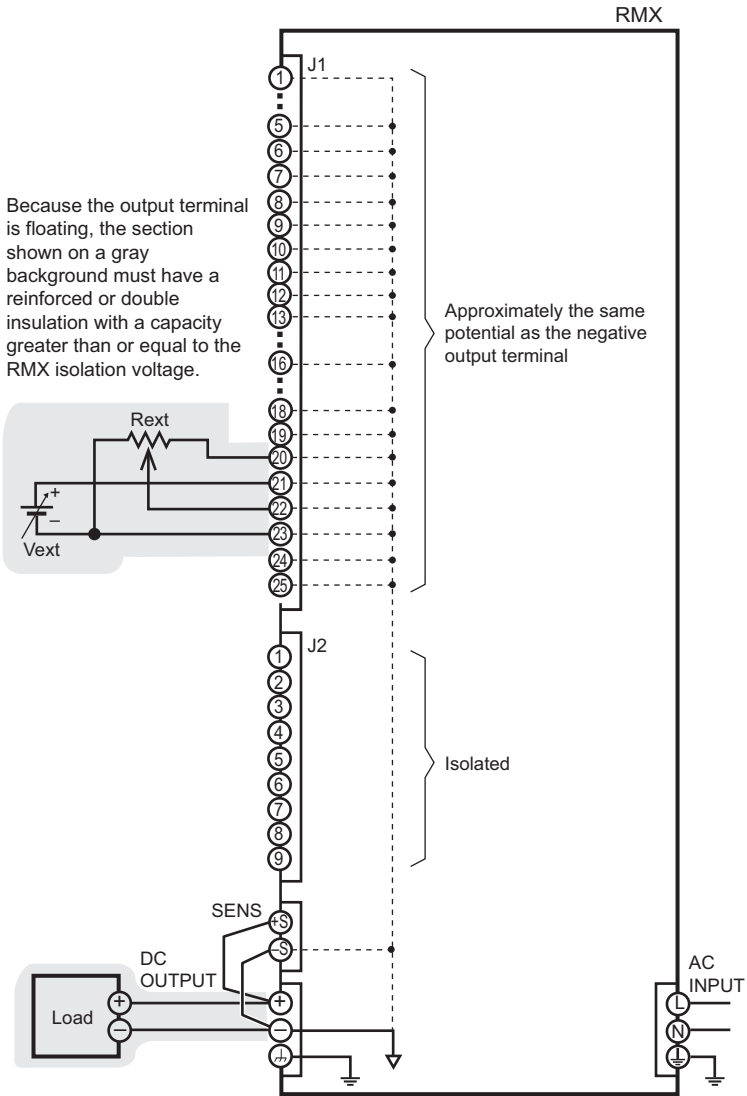
The cable and load that are connected to the output terminal (including the sensing terminal) must have a reinforced or double insulation with a capacity that is greater than or equal to the isolation voltage of the RMX programmable power supply with respect to the chassis. Isolation voltage indicates the maximum allowed voltage that appears across the output terminal of the power supply unit and the protective conductor terminal (chassis terminal).

## When the Output Terminal is Not Grounded (Floating)

The output terminal of the RMX programmable power supply is isolated from the protective conductor terminal. If you connect the GND wire of the power cord to the ground terminal of the switchboard, the chassis of the RMX programmable power supply is set to ground potential.

Pins 5 to 13 (for external control and parallel operation) and 18 to 25 (for external control and output monitoring) of the rear panel J1 connector are at approximately the same electric potential as the RMX programmable power supply negative output terminal. Cables and devices that are connected to these pins must have a reinforced or double insulation with a capacity greater than or equal to the isolation voltage of the RMX programmable power supply.

**Figure 3-8.** Output Terminal is Not Grounded (Floating)



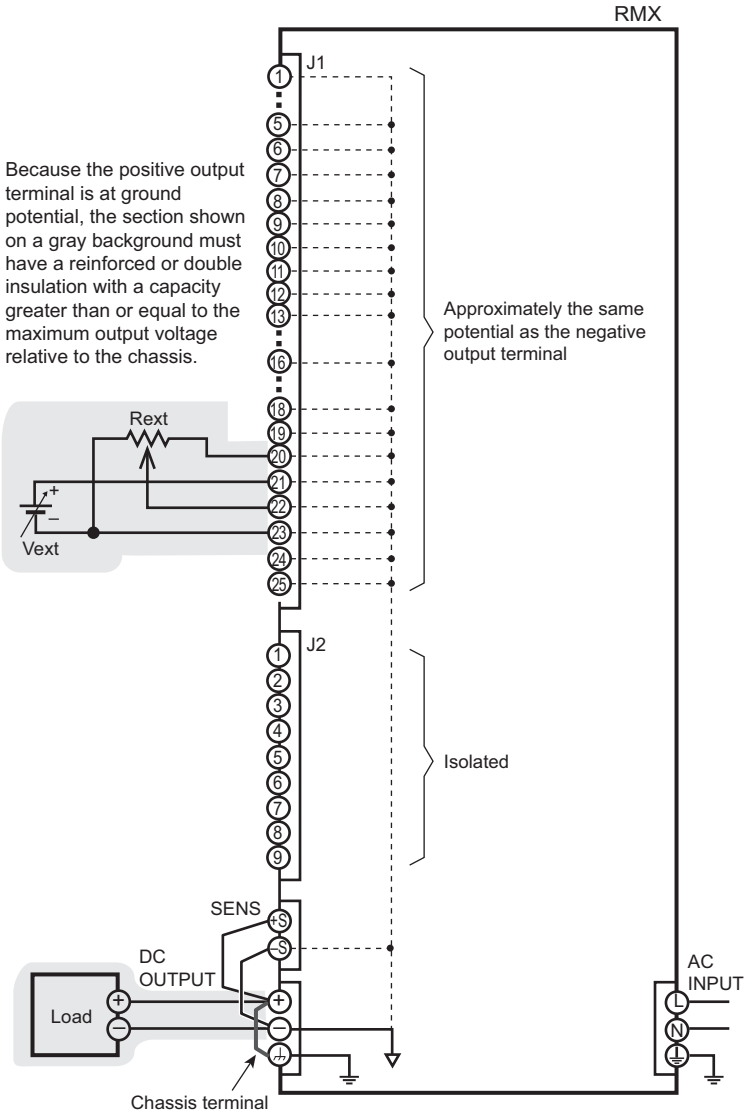
## When the Output Terminal is Grounded

If the positive output terminal is connected to the chassis terminal, the positive output terminal is at ground potential. The cable and load that are connected to the output terminal (including the sensing terminal) will only require an insulation capacity that is greater than or equal to the maximum output voltage of the RMX programmable power supply with respect to the chassis. There is no need to provide insulation that is greater than or equal to the isolation voltage of the RMX programmable power supply.

The same holds true when the negative terminal is connected to the chassis terminal. The cable and load require a reinforced or double insulation with a capacity that is greater than or equal to the maximum output voltage of the RMX programmable power supply.

For safety reasons, connect one of the output terminals to the chassis terminal unless your application requires the output terminals to be floating.

Figure 3-9. Output Terminal is Grounded





# Cautions When Controlling the Output with an External Voltage (Vext)

You must take careful precautions when connecting external equipment to the J1 connector to make sure you do not unknowingly short both output terminals to ground.

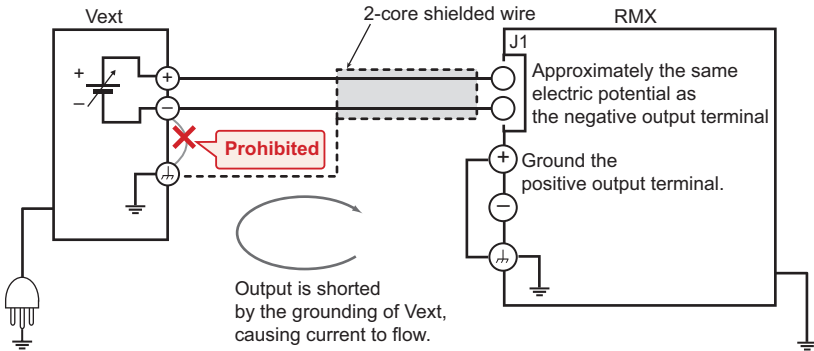
Connect the cables so that output is not shorted. See the following figures for examples of shorted output.



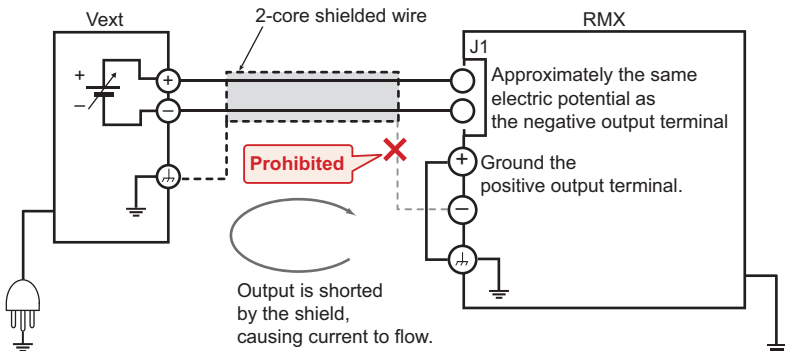
**Caution** The Vext cable must not be referenced/connected to the chassis ground terminal. The signal must be floating relative to ground. Connecting/referencing this signal to ground may cause the cable to be damaged. Refer to Figures 3-10 and 3-11 for more information.

If you are connecting the shield to the Vext side, do not connect the shield to the output terminal of the RMX programmable power supply.

**Figure 3-10.** Connection Where the Output is Shorted by the Grounding of Vext



**Figure 3-11.** Connection Where the Output is Shorted by the Shield



# Controlling the Output Voltage

This section explains how to control the output voltage using an external voltage ( $V_{ext}$ ) or an external variable resistor ( $R_{ext}$ ) of approximately 10 k $\Omega$ .

If no load is connected, it takes some time for the output voltage to decrease. There may be a delay between when you request a new voltage with  $V_{ext}$  or  $R_{ext}$  and when it shows up on the output terminals.



**Caution** Risk of electric shock. If neither output terminal is tied to chassis ground, the reinforced or double insulation of  $V_{ext}$  or  $R_{ext}$  and the connected cable must be greater than or equal to the isolation voltage of the RMX programmable power supply. Refer to Appendix A, *Specifications*, for the isolation voltage of your model.

If one of the output terminals is connected to chassis ground, the insulation of  $V_{ext}$  or  $R_{ext}$  and the connected cable must have a reinforced or double insulation with a capacity greater than or equal to the maximum output voltage relative to the chassis

When using shielded cables for the connection, for uncovered sections of the shielded cables, use insulation tubes to secure reinforced or double insulation with a capacity greater than or equal to the isolation voltage of the RMX programmable power supply.

## Control Using an External Voltage ( $V_{ext}$ )

To use an external voltage ( $V_{ext}$ ) to control the output voltage, set CONFIG setting CF06 to ON to enable control of the output voltage using an external voltage.

The output voltage ( $E_o$ ) varies in the range of 0 to the rated output voltage ( $E_{rtg}$ ) when the external voltage ( $V_{ext}$ ) is changed in the range of 0 to 5 V (CF07: Lo) or in the range of 0 to 10 V (CF07: Hi).

External voltage ( $V_{ext}$ ) 0 to 5 V (CF07: Lo)	External voltage ( $V_{ext}$ ) 0 to 10 V (CF07: Hi)
$E_o = E_{rtg} \times V_{ext}/5$ (in V) $V_{ext} = 5 \times E_o/E_{rtg}$ (in V)	$E_o = E_{rtg} \times V_{ext}/10$ (in V) $V_{ext} = 10 \times E_o/E_{rtg}$ (in V)



**Caution** The  $V_{ext}$  cable must not be referenced/connected to the chassis ground terminal. The signal must be floating relative to ground. Connecting/referencing this signal to ground may cause the cable to be damaged. Refer to Figures 3-10 and 3-11 for more information.

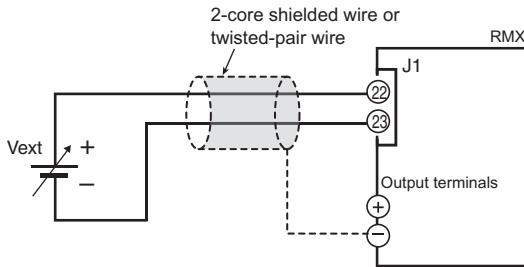
Pay careful attention to the polarity of  $V_{ext}$ . Do not apply a voltage of 10.5 V or greater, or a reverse voltage across the external voltage control pins.

## External Voltage (Vext) Connection

Use a low-noise, stable voltage source for Vext. The noise in Vext is multiplied by the amplification factor of the RMX programmable power supply and appears in the output. A noisy Vext source can cause the output ripple noise of the RMX power supply to not meet its specifications.

To reduce the noise on the output, connect a 2-core shielded wire or a twisted-pair wire, and keep the wire as short as possible. If the wiring between the RMX programmable power supply and the external contact is long, it becomes easy for noise to influence the operation of the RMX programmable power supply. Even if you use cables that are designed to suppress noise, the RMX programmable power supply may not operate properly.

**Figure 3-12. CV Vext Connection.**



If you use a shielded cable, connect the shield to the negative output terminal. Refer to [Cautions When Controlling the Output with an External Voltage \(Vext\)](#) if the shield needs to be connected to the Vext side. Use pins 22 and 23 of the J1 connector.

## Control Using an External Resistance (Rext)

An external variable resistor (Rext) can be used along with the Reference Voltage Output (pin 20 on the J1 connector) to externally control the output voltage of the power supply. You can use this method to set the output voltage (Eo) to a value from 0% to 105% of the rated output voltage (Ertg).

To use an external resistance (Rext) to control the output voltage, set CONFIG setting CF06 to ON to enable control of the output voltage using an external resistor.

The output voltage (Eo) varies in the range of 0 to the rated output voltage (Ertg) when the external voltage (Vext) is changed in the range of 0 to 5 V (CF07: Lo) or in the range of 0 to 10 V (CF07: Hi).

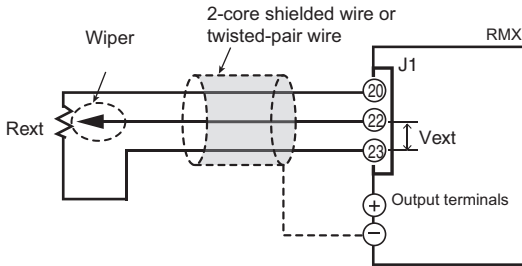
External voltage (Vext) 0 to 5 V (CF07: Lo)	External voltage (Vext) 0 to 10 V (CF07: Hi)
$E_o = E_{rtg} \times V_{ext}/5$ (in V) $V_{ext} = 5 \times E_o/E_{rtg}$ (in V)	$E_o = E_{rtg} \times V_{ext}/10$ (in V) $V_{ext} = 10 \times E_o/E_{rtg}$ (in V)

## External Resistance (R<sub>ext</sub>) Connection

For R<sub>ext</sub>, use a resistor that is rated at approximately 10 k $\Omega$ , 1/2 W or greater, that has a low temperature coefficient, and that will change little over time. Examples of such resistors are metal film or wire wound resistors.

To reduce the noise on the output, connect a 2-core shielded wire or a twisted-pair wire, and keep the wire as short as possible. If the wiring between the RMX programmable power supply and the external contact is long, it becomes easy for noise to influence the operation of the RMX programmable power supply. Even if you use cables that are designed to suppress noise, the RMX programmable power supply may not operate properly.

**Figure 3-13.** CV R<sub>ext</sub> Connection.



If you use a shielded cable, connect the shield to the negative output terminal. Use pins 20, 22, and 23 of the J1 connector.

## Controlling the Output Current

This section explains how to control the output current using an external voltage (V<sub>ext</sub>) or an external variable resistor of approximately 10 k $\Omega$  (R<sub>ext</sub>).



**Caution** Risk of electric shock. If neither output terminal is tied to chassis ground, the reinforced or double insulation of V<sub>ext</sub> or R<sub>ext</sub> and the connected cable must be greater than or equal to the isolation voltage of the RMX programmable power supply. Refer to Appendix A, *Specifications*, for the isolation voltage of your model.

If one of the output terminals is connected to chassis ground, the insulation of V<sub>ext</sub> or R<sub>ext</sub> and the connected cable must have a reinforced or double insulation with a capacity greater than or equal to the maximum output voltage relative to the chassis.

When using shielded cables for the connection, for uncovered sections of the shielded cables, use insulation tubes to secure reinforced or double insulation with a capacity greater than or equal to the isolation voltage of the RMX programmable power supply.

## Control Using an External Voltage (Vext)

To use an external voltage (Vext) to control the output current, set CONFIG setting CF05 to ON to enable control of the output current using an external voltage.

The output current (Io) varies in the range of 0 to the rated output current (Irtg) when the external voltage (Vext) is changed in the range of 0 to 5 V (CF07: Lo) or in the range of 0 to 10 V (CF07: Hi).

External voltage (Vext) 0 to 5 V (CF07: Lo)	External voltage (Vext) 0 to 10 V (CF07: Hi)
$I_o = I_{rtg} \times V_{ext}/5$ (in A) $V_{ext} = 5 \times I_o/I_{rtg}$ (in A)	$I_o = I_{rtg} \times V_{ext}/10$ (in A) $V_{ext} = 10 \times I_o/I_{rtg}$ (in A)



**Caution** The Vext cable must not be referenced/connected to the chassis ground terminal. The signal must be floating relative to ground. Connecting/referencing this signal to ground may cause the cable to be damaged. Refer to Figures 3-10 and 3-11 for more information.

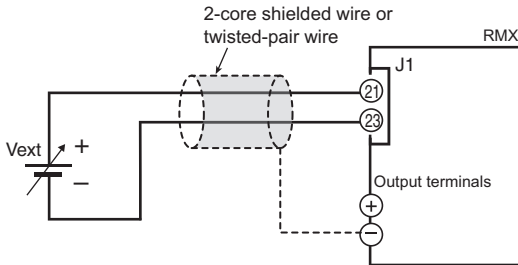
Pay careful attention to the polarity of Vext. Do not apply a voltage of 10.5 V or greater, or a reverse voltage across the external voltage control pins.

### External voltage source (Vext) connection

Connect a low-noise, stable voltage source to Vext. The noise in Vext is multiplied by the amplification factor of the RMX programmable power supply and appears in the output. A noisy Vext source can cause the output ripple noise of the RMX power supply to not meet its specifications.

To reduce the noise on the output, connect a 2-core shielded wire or a twisted-pair wire, and keep the wire as short as possible. If the wiring between the RMX programmable power supply and the external contact is long, it becomes easy for noise to influence the operation of the RMX programmable power supply. Even if you use cables that are designed to suppress noise, the RMX programmable power supply may not operate properly.

**Figure 3-14. CC Vext Connection.**



If you use a shielded cable, connect the shield to the negative output terminal. Refer to [Cautions When Controlling the Output with an External Voltage \(Vext\)](#) if the shield needs to be connected to the Vext side. Use pins 21 and 23 of the J1 connector.

## Control Using an External Resistance (Rext)

An external variable resistor (Rext) can be used along with the Reference Voltage Output (pin 20 on the J1 connector) to externally control the output current of the power supply. You can use this method to set the output current (Io) to a value from 0% to 105% of the rated output current (Irtg).

To use an external resistance (Rext) to control the output current, set CONFIG setting CF05 to ON to enable control of the output current using an external resistor.

The output current (Io) varies in the range of 0 to the rated output current (Irtg) when the external voltage (Vext) is changed in the range of 0 to 5 V (CF07: Lo) or in the range of 0 to 10 V (CF07: Hi).

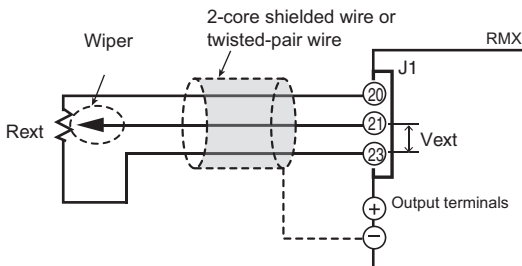
External voltage (Vext) 0 to 5 V (CF07: Lo)	External voltage (Vext) 0 to 10 V (CF07: Hi)
$I_o = I_{rtg} \times V_{ext}/5$ (in A) $V_{ext} = 5 \times I_o/I_{rtg}$ (in A)	$I_o = I_{rtg} \times V_{ext}/10$ (in A) $V_{ext} = 10 \times I_o/I_{rtg}$ (in A)

## External Resistance (Rext) Connection

For Rext, use a resistor that is rated at approximately 10 kΩ, 1/2 W or greater, that has a low temperature coefficient, and that will change little over time. Examples of such resistors are metal film or wire wound resistors.

To reduce the noise on the output, connect a 2-core shielded wire or a twisted-pair wire, and keep the wire as short as possible. If the wiring is long, it becomes easy for noise to influence the operation of the RMX programmable power supply. Even if you use wires that are designed to suppress noise, the RMX programmable power supply may not operate properly.

**Figure 3-15. CC Rext Connection.**



If you use a shielded cable, connect the shield to the negative output terminal. Use pins 20, 21, and 23 of the J1 connector.

# Controlling the Output On and Off States

---

This section explains how to use an external contact to control the output on and off states.



**Caution** Risk of electric shock. If neither output terminal is tied to chassis ground, the reinforced or double insulation of the external contact (S) and the connected cable must be greater than or equal to the isolation voltage of the RMX programmable power supply. Refer to Appendix A, *Specifications*, for the isolation voltage of your model.

If one of the output terminals is connected to chassis ground, the insulation of external contact (S) and the connected cable must have a reinforced or double insulation with a capacity greater than or equal to the maximum output voltage relative to the chassis.

When using shielded cables for the connection, for uncovered sections of the shielded cables, use insulation tubes to secure reinforced or double insulation with a capacity greater than or equal to the isolation voltage of the RMX programmable power supply.

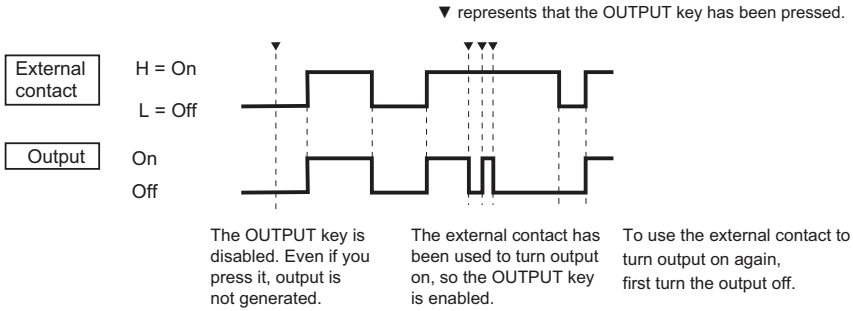
To reduce the noise on the output, connect a 2-core shielded wire or a twisted pair wire, and keep the wire as short as possible. If the wiring is long, it becomes easy for noise to influence the operation of the RMX programmable power supply. Even if you use wires that are designed to suppress noise, the RMX programmable power supply may not operate properly. If you use a shielded cable, connect the shield to the negative output terminal.

Set CONFIG parameter CF09 to ON to use an external contact to control the output on and off state of the device.

- Turn the output on with a low signal (CF10: Lo). Output is turned on when a LOW (0 to 0.5 V) or short-circuit is applied between pin 18 and 19 of the J1 connector.
- Turn the output on with a high signal (CF10: Hi). Output is turned on when a HIGH (4.5 to 5 V) or open-circuit is applied between pin 18 and 19 of the J1 connector.

When the external contact has put the output into the off state, the OUTPUT key on the front panel will not have any effect on the output signal. When the external contact has put the output into the on state, the OUTPUT key on the front panel can still turn the output off and on. Refer to Figure 3-16 for more information about how a high signal is used to turn the output on.

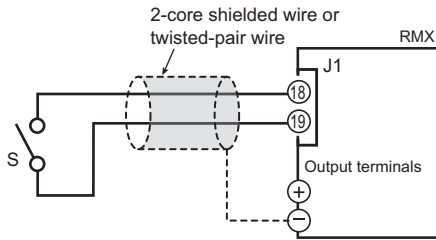
**Figure 3-16. Controlling the Output On and Off States.**



## External Contact Connection

Connect your external contact between pins 18 and 19 of the J1 connector. The open-circuit voltage across pins 18 and 19 is approximately 5 V. The short-circuit current across pins 18 and 19 is approximately 0.5 mA.

**Figure 3-17. External Contact Connection.**

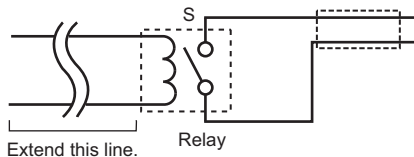


Use external contacts that have a contact rating of 0.5 mA or more at 5 VDC. If two or more units are floating and you are using a single external contact to turn output on and off for all the units, use a relay or similar device for the external contact signal to isolate the signal transmitted to each unit.

## Long-Distance Wiring

When you are wiring over a great distance, use a small relay and extend the coil side of the relay.

**Figure 3-18. Long Distance Wiring.**





# Controlling Output Shutdown

---

This section explains how to use an external contact to turn output off. This functionality differs from the *Controlling the Output On and Off States* external control pin, because recovering from an output shutdown requires the unit to be power cycled.



**Caution** Risk of electric shock. If neither output terminal is tied to chassis ground, the reinforced or double insulation of the external contact (S) and the connected cable must be greater than or equal to the isolation voltage of the RMX programmable power supply. Refer to Appendix A, *Specifications*, for the isolation voltage of your model.

If one of the output terminals is connected to chassis ground, the insulation of the external contact and the connected cable must have a reinforced or double insulation with a capacity greater than or equal to the maximum output voltage relative to the chassis.

When using shielded cables for the connection, for uncovered sections of the shielded cables, use insulation tubes to secure reinforced or double insulation with a capacity greater than or equal to the isolation voltage of the RMX programmable power supply.

To reduce the noise on the output, connect a 2-core shielded wire or a twisted pair wire, and keep the wire as short as possible. If the wiring is long, it becomes easy for noise to influence the operation of the RMX programmable power supply. Even if you use wires that are designed to suppress noise, the RMX programmable power supply may not operate properly.

If you use a shielded cable, connect the shield to the negative output terminal.

If you apply a LOW (0 to 0.5 V) or short-circuit pin 6 to pin 19 of the J1 connector, the output shuts down.

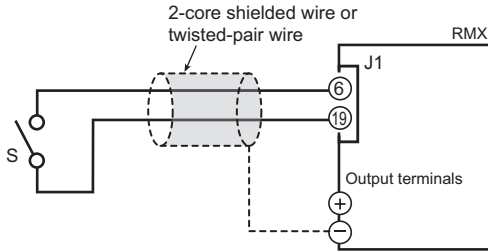
To recover, set pin 6 of the J1 connector to HIGH (4.5 to 5 V) or open the pin, and then turn the POWER switch off and then on.

## Output Shutdown Connection

Connect your external contact between pins 6 and 19 of the J1 connector. The open-circuit voltage across pins 6 and 19 is approximately 5 V. The short-circuit current across pins 6 and 19 is approximately 0.5 mA.

Use external contacts that have a contact rating greater than or equal to 0.5 mA at 5 VDC.

**Figure 3-19.** Output Shutdown Connection.

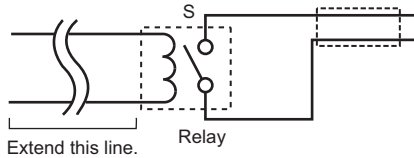


If two or more units are floating, and you are using a single external contact to turn output off for all the units, use a relay or similar device for the external contact signal to isolate the signal transmitted to each unit.

## Long-Distance Wiring

When you are wiring over a great distance, use a small relay and extend the coil side of the relay.

**Figure 3-20.** Long Distance Wiring.



## Controlling the Clearing of Alarms

This section explains how to use an external contact to clear alarms.



**Caution** Risk of electric shock. If neither output terminal is tied to chassis ground, the reinforced or double insulation of the external contact (S) and the connected cable must be greater than or equal to the isolation voltage of the RMX programmable power supply. Refer to Appendix A, *Specifications*, for the isolation voltage of your model.

If one of the output terminals is connected to chassis ground, the insulation of the external contact and the connected cable must have a reinforced or double insulation with a capacity greater than or equal to the maximum output voltage relative to the chassis.

When using shielded cables for the connection, for uncovered sections of the shielded cables, use insulation tubes to secure reinforced or double insulation with a capacity greater than or equal to the isolation voltage of the RMX programmable power supply.

To reduce the noise on the output, connect a 2-core shielded wire or a twisted pair wire, and keep the wire as short as possible. If the wiring is long, it becomes easy for noise to influence the operation of the RMX programmable power supply. Even if you use wires that are designed to suppress noise, the RMX programmable power supply may not operate properly.

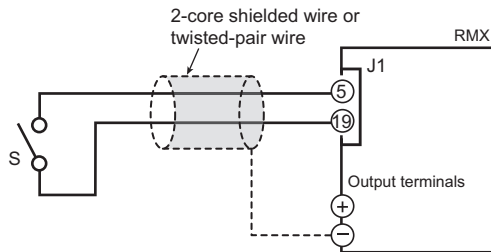
If you use a shielded cable, connect the shield to the negative output terminal. If you apply a LOW (0 to 0.5 V) or short-circuit to pin 5 of the J1 connector, the alarms will be cleared.

## Alarm Clear Connection

Connect your external contact between pins 5 and 19 of the J1 connector. The open-circuit voltage across pins 5 and 19 is approximately 5 V. The short-circuit current across pins 5 and 19 is approximately 0.5 mA.

Use external contacts that have a contact rating greater than or equal to 0.5 mA at 5 VDC.

**Figure 3-21. Alarm Clear Connection.**

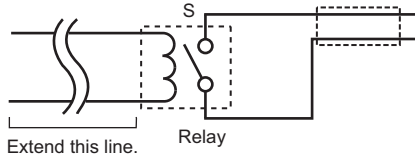


If two or more units are floating, and you are using a single external contact to clear alarms, use a relay or similar device for the external contact signal to isolate the signal transmitted to each unit.

## Long-Distance Wiring

When you are wiring over a great distance, use a small relay and extend the coil side of the relay.

**Figure 3-22.** Long Distance Wiring.



## External Monitoring

The J1 connector has monitor outputs for the output voltage and the output current.

**Table 3-3.** External Monitoring of J1 Connector Output Voltage and Output Current

Pin	Signal Name	Description
10, 19, 23,	A COM	Remote control input common Output monitor common
25	V MON	Monitor output of output voltage 0 to approximately 5 V (CF08: Lo) or 0 to approximately 10 V (CF08: Hi) for 0 to the rated output voltage
24	I MON	Monitor output of output current 0 to approximately 5 V (CF08: Lo) or 0 to approximately 10 V (CF08: Hi) for 0 to the rated output current



**Caution** Shorting V MON and I MON to A COM may damage the RMX programmable power supply.

## Monitor Output Rating

- Output impedance: 1 kΩ or less. Maximum output current: Approximately 10 mA.

The monitor output signals are used to monitor the DC voltage (mean value). They cannot be used to accurately monitor the AC components (such as ripple and transient response waveform) of the actual output voltage or current.

## External Monitoring of the Operation Status

The J2 connector has status outputs that can be used to externally monitor the operation status of the RMX programmable power supply. The following five items make up the status outputs.

The outputs are open collector outputs of photocouplers; they are isolated from the internal circuits of the RMX programmable power supply. The status common is floating (that is, it has an isolation voltage of less than or equal to 60 V).

The above signal output circuit is protected with reinforced insulation from the MAINS.

The maximum ratings of the signal terminals are as follows:

- Maximum voltage: 30 V.
- Maximum current (sink): 8 mA.

**Table 3-4.** External Monitoring of the J2 Connector Signal Terminals Operation Status

Pin	Signal	Description	Circuit
6-9	STATUS COM	This is the status output common. This is the photocoupler emitter output.	
1	CV STATUS	This is set to low level when the RMX programmable power supply is in constant voltage mode. This is the photocoupler open collector output.	
2	CC STATUS	This is set to low level when the RMX programmable power supply is in constant current mode. This is the photocoupler open collector output.	
3	ALM STATUS	This is set to low level when a protection function (OVP/OVP2/ OCP/ OHP/ OHP2/ FAN/ SEN/ AC-FAIL/ SD) is activated. This is the photocoupler open collector output.	
4	PWRONSTATUS	This is set to low level when the RMX programmable power supply is turned on (PWR ON STATUS). This is the photocoupler open collector output.	
5	OUTONSTATUS	This is set to low level when the output is turned on. This is the photocoupler open collector output	

---

# Parallel/Series Operation

This chapter describes the functions of series and master-slave parallel operations as well as the connection, setup, and operation procedures.

## Master-Slave Parallel Operation

---

In master-slave parallel operation, one unit is the master unit, and all other units connected in parallel are slave units. The master and slave units must all be the same model. You can control the whole system by operating the master.

You can use master-slave parallel operation to expand the output current (maximum output current: the rated output current of one unit  $\times$  the number of units connected in parallel).

You can connect up to four units, including the master, in parallel. The difference in the output voltage and output current between the master unit and the slave units is within approximately 5% of the rating.



**Caution** When using the RMX programmable power supply independently or when there are units not using parallel operation, disconnect the parallel operation connections. Otherwise, the RMX programmable power supply may not operate properly.

## Features of the RMX Programmable Power Supplies During Master-Slave Parallel Operation

The features of the RMX programmable power supplies during master-slave parallel operation are as follows:

### Voltage Display and Current Display

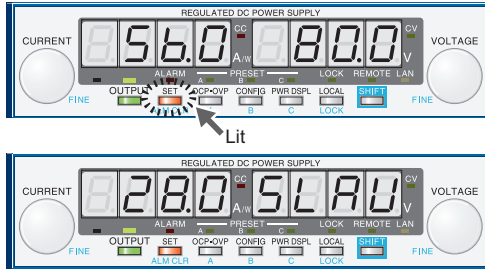
The voltmeter on the master unit displays the voltage. The last voltage that was set on the master unit is displayed. The voltmeters on the slave units display **SLAV**. The master unit's ammeter displays the total of the currents of all the units connected in parallel. Each slave unit displays its own current.

If the maximum output current exceeds 99.99, the maximum current is displayed as 999.9.

You can switch the display so that it shows power. The master unit's ammeter displays the sum of the power output of all the units connected in parallel. Each slave unit displays its own power.

If the number of units during master-slave parallel operation that has been specified in the CONFIG settings (CF01) does not match the actual number of units connected in parallel, the correct current will not be displayed.

**Figure 4-1. Master Unit and Slave Unit**



### External Control

This is only available on the master unit.

### External Monitoring



**Caution** During master-slave parallel operation, do not connect the monitor common cable of the master unit to the monitor common cables of the slave units. If the cables connected to the load are disconnected, the common cables will be damaged.

- **External monitoring of the output voltage (V MON)**—This can be monitored from the master unit.
- **External monitoring of the output current (I MON)**—You can monitor the output current of the master unit and each slave unit. Use the master unit to monitor the total output current.
- **Status monitors**—You can monitor the status of the following items from the master unit and from each slave unit: constant-voltage mode (CV STATUS), constant-current mode (CC STATUS), output on, POWER switch on, and alarms. However, slave units always output the status of constant-current mode.

### Remote Sensing

This is only available on the master unit.

### Alarm

If an alarm is detected, the units behave as follows:

- **Master Unit**—If an alarm is detected on the master unit, output of each slave unit is turned off, and then the output of the entire system is turned off.
- **Slave Unit**—The slave unit independently enters the alarm state and turns its output off. The output does not turn off on the master and other slave units.

You can use the CONFIG settings to specify what happens when the output is turned off because an alarm is detected. You can select to turn the output on automatically when the problem that caused the alarm is fixed (CF03: Auto) or to leave the output turned off when the problem is fixed (CF03: SAFE). (This parameter only applies to the OHP, FAN, and AC-FAIL errors.)

### Clearing Alarms

To clear alarms, (1) press ALM CLR (SHIFT+SET); (2) set pin 5 of the J1 connector to LOW (0 to 0.5 V) or shorted; or (3) turn off the slave units, turn off the master unit, fix the problem that caused the alarm, turn on the slave units, and then turn on the master unit.

## Connection (Master-Slave Parallel Operation)

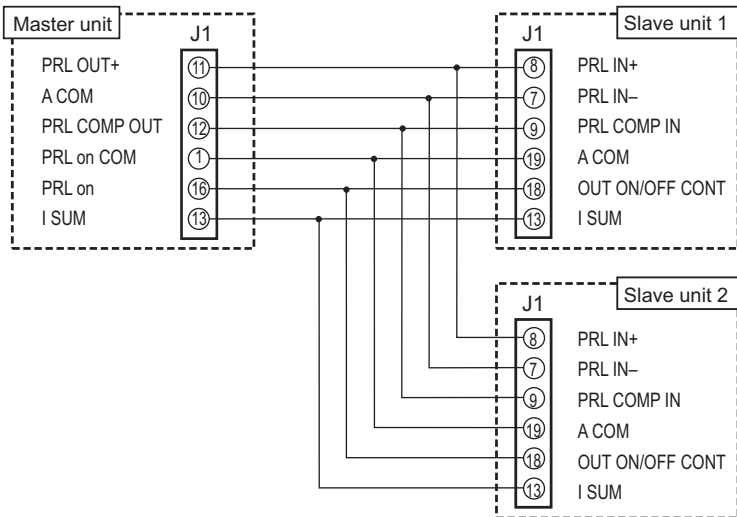
You can connect up to four units, including the master unit.

### Connecting the Signal Cables (Parallel Operation)

Use the J1 connector to make the connections for parallel operation. The cables that are required to make the connection are not included. Refer to the *About the J1 Connector* section of Chapter 3, *External Control*, for details about the connector.

If you are using the optional parallel operation signal cable (PC01, PC02, or PC03-RMX), the connector is already assembled, so you can use it as is.

**Figure 4-2. Connecting Two Slave Units**





1. Decide which RMX programmable power supply to use as the master unit.
2. Connect the J1 connector on the rear panel of the master unit to the J1 connector on the rear panel of the first slave unit.

If you are using the optional parallel operation signal cable (PC01, PC02, or PC03-RMX), the connector is already assembled, so you can use it as is.

3. Connect the J1 connector on the rear panel of the first slave unit to the J1 connector on the rear panel of the second slave unit. If you are using the optional parallel operation signal cable (PC01, PC02, or PC03-RMX), the connector is already assembled, so you can use it as is.

If you have a third slave unit, connect it in the same manner.

## Connecting the Load (Parallel Operation)



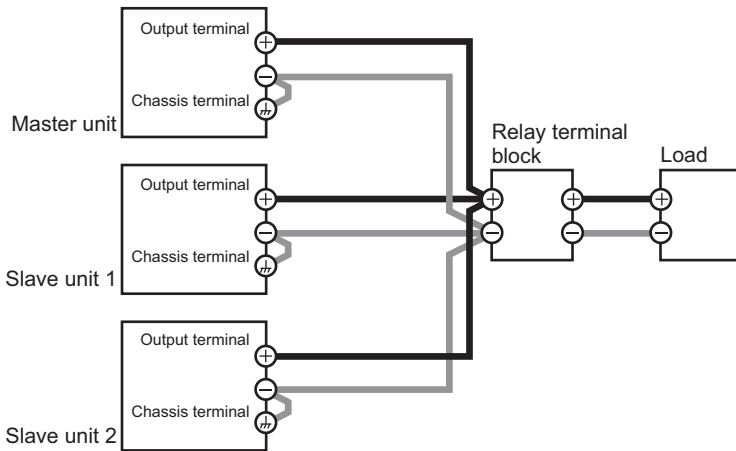
**Caution** Risk of electric shock. Turn the POWER switch off before you touch the OUTPUT terminals. Attach the OUTPUT terminal cover after you finish wiring the load.

- When you connect the output terminals to the chassis terminals, be sure to connect the same polarity output terminals (positive or negative) of the master unit and the slave units to the chassis terminals. If you connect different polarity output terminals of the master unit and the slave units to the chassis terminal, the output will be grounded through the power cable's GND wire. Not only will this make the output incorrect, it will also cause the chassis terminal cable to burn out.
- When the load cables are distributed over longer distance, the phase shifting due to wiring inductance and capacitance may go beyond the limit and result in oscillation. To prevent such oscillation, connect an electrolytic capacitor with several hundreds to several tens of thousands  $\mu\text{F}$  across the load.

Use an electrolytic capacitor that has a withstand voltage that is at least 120% of the product's rated output voltage.

- Twist the positive and negative cables together, and make the connection to the load as short as possible. Oscillation may occur as a result of wiring inductance.

**Figure 4-3. Load Connections for Parallel Operation**



Complete the following steps to connect the load for parallel operation.

1. Turn off all the RMX programmable power supplies that you want to connect in parallel.
2. Remove the OUTPUT terminal covers.
3. Connect the load cables to the output terminals of the master unit and the slave units.
4. Connect the load cables of the master unit and slave units to the load through a relay terminal block.

Use load cables that have sufficient current capacity. Use load cables of equivalent length and cross-sectional area to connect each power supply to the relay terminal block, and wire the cables so that they are as short as possible (50 cm or less). Also, make the connection from the relay terminal block to the load block as short as possible.

Wire the J1 connector signal cables and the load cables as far apart as possible.

5. Connect the output terminals (positive or negative) of the master unit and the slave units to the chassis terminals.

Connect the same polarity output terminals on the master unit and slave units. If you are using the units under floating conditions, do not connect the terminals.

6. Attach the OUTPUT terminal covers.

If you have a third and fourth slave unit, connect them in the same manner.

## Settings (Master-Slave Parallel Operation)

### Setting the Master Unit, the Slave Units, and the Number of Units in Parallel Operation (Including the Master Unit)

Turn the output off, and then configure the master unit (CF01: 2 to 4) and the slave units (CF01: SLAV) in master-slave parallel operation. On the master unit, set the number of units in master-slave parallel operation (CF01: 2 to 4). By factory default, the RMX programmable power supply is set to independent operation (CF01: 1).

Turn the POWER switch off and on to enable the setting. Be sure to set the number of units in master-slave parallel operation (CF01) to the actual number of units that are connected. If this parameter is incorrect, settings such as those for the current and the overcurrent protection (OCP) cannot be set correctly, and the measured current will not be displayed correctly.

### Setting the Voltage and Current

Use the master unit to set the voltage and current. The current that is output is the sum of the currents of the master unit and the slave units. When you set the number of units in master-slave parallel operation (CF01), the maximum output current (105% of the rated output current of a single unit  $\times$  the number of units in parallel) is set. If you switch to the setting display (when the SET key is lit), this value is displayed. The last voltage that was set on the master unit is used. When you press OUTPUT, the set voltage and current are output. You can set the voltage and current to any values.

### Setting the Overvoltage Protection (OVP) and Overcurrent Protection (OCP) of the Master Unit

When you are performing master-slave parallel operation, set the overvoltage protection (OVP) and overcurrent protection (OCP) of the master unit. When you set the number of units in master-slave parallel operation (CF01), the maximum overcurrent protection value (112% of the rated output current of a single unit  $\times$  the number of units in parallel) is set. If you switch to the OVP/OCP setting display (when the OCP•OVP key is lit), this value is displayed. The last overvoltage protection value that was set on the master unit is used.

**Table 4-1.** CONFIG Parameters for Master Units

Parameter	Description
CF00	Resets the panel settings
CF02	Power-on status parameter
CF04	Memory content display parameter
CF05	CC control using an Vext or Rext
CF06	CV control using an Vext or Rext

**Table 4-1.** CONFIG Parameters for Master Units (Continued)

Parameter	Description
CF07	CV/CC control range parameter
CF09	External control parameter for turning output on and off
CF10	External control logic parameter for turning output on and off
CF12	Output-on startup state parameter
CF14	Current setting limit
CF15	Voltage setting limit

## Starting Master-Slave Parallel Operation

### Turning Power On

1. Turn the master unit’s POWER switch on.
2. Turn the POWER switch of each slave unit on.
3. Operate the master unit normally. You cannot perform panel operations on the slave units. Turn output on and off from the master unit.

### Turning Power Off

1. Turn the slave unit’s POWER switch off.
2. Turn the master unit’s POWER switch off.



**Caution** After you turn the POWER switch off, wait at least 10 seconds after the panel display turns off before you turn the POWER switch back on. Repeatedly turning the POWER switch on and off at short intervals can cause damage to the inrush current limiter. In turn, this will shorten the service life of the POWER switch, internal input fuse, and other components.

# Series Operation



**Caution** The RMX-4123 and RMX-4127 cannot be used in series operation. If you do, the output will exceed the isolation voltage resulting in a dangerous condition.

Except for the RMX-4123 and RMX-4127, you can connect up to two units in series. You cannot perform master-slave series operation. The total of the output voltages of the two units is applied to the load. The voltage setting accuracy is the same as the accuracy of an individual unit.

## Features of the RMX Programmable Power Supplies During Series Operation

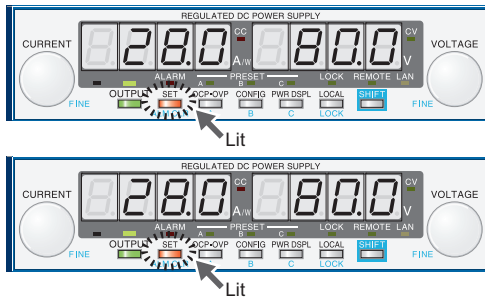
The features of the RMX programmable power supplies during series operation are as follows:

### Voltage Display and Current Display

The voltage and current are displayed on unit 1 and unit 2. To calculate the total output voltage, add the voltages of unit 1 and unit 2.

You can switch the display so that it shows power. The power is displayed on unit 1 and unit 2.

**Figure 4-4.** Panel Display During Series Operation



### External Control

External control is available when connecting two units together in series.

### External Monitoring



**Caution** During monitoring, be careful of shorts and electric shocks. When monitoring the output voltage or output current during master-slave series operation, the electric potential of the commons of the master unit's monitor signal and the slave unit's monitor signal are different.

- **External monitoring of the output voltage (V MON)**—You can monitor the output voltage of each unit from pin 25 of the J1 connector. To calculate the total output voltage, add the monitor values of the master unit and the slave unit.
- **External monitoring of the output current (I MON)**—This can only be monitored from pin 25 on the master unit's J1 connector.
- **Status Monitors**—You can monitor the status of the following items from the J2 connector on the master unit and from the slave unit: constant-voltage mode (CV STATUS), constant-current mode (CC STATUS), output on, POWER switch on, and alarms.

## Remote Sensing

To perform remote sensing, connect the RMX programmable power supplies in series, and then connect the sensing cables to them as shown in the following figure.

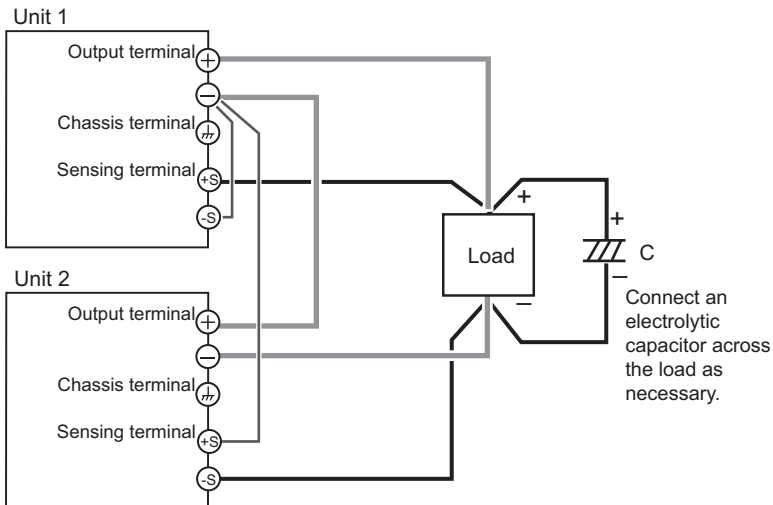


**Caution** If the sensing cables are not connected properly, the load may be exposed to excessive voltage, and the RMX programmable power supplies may be damaged.

When the load cables are distributed over longer distance, the phase shifting due to wiring inductance and capacitance may go beyond the limit and result in oscillation. To prevent such oscillation, connect an electrolytic capacitor with several hundreds to several tens of thousands  $\mu\text{F}$  across the load.

Use an electrolytic capacitor with a withstand voltage that is 120% or more of the total of the rated output voltages of the RMX programmable power supplies that are connected in series.

**Figure 4-5. Connecting the Sensing Cables During Series Operation**



## Alarm

All the alarms that are detected on a single unit are also detected during series operation.

You can use the CONFIG settings to specify what happens when the output is turned off because an alarm is detected. You can select to turn the output on automatically when the problem that caused the alarm is fixed (CF03: Auto) or to leave the output turned off when the problem is fixed (CF03: SAFE).

## Clearing Alarms

To clear alarms, (1) press ALM CLR (SHIFT+SET); (2) set pin 5 of the J1 connector to LOW (0 to 0.5 V) or shorted; or (3) turn off unit 1 and unit 2, fix the problem that caused the alarm, and then turn on unit 1 and unit 2.

## Connection (Series Operation)

You can connect up to two units.

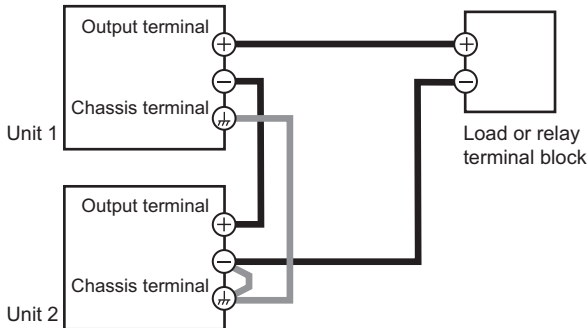


**Caution** Risk of electric shock. Turn the POWER switch off before you touch the OUTPUT terminals. Attach the OUTPUT terminal cover after you finish wiring the load.

When the load cables are distributed over longer distance, the phase shifting due to wiring inductance and capacitance may go beyond the limit and result in oscillation. To prevent such oscillation, connect an electrolytic capacitor with several hundreds to several tens of thousands  $\mu\text{F}$  across the load. Use an electrolytic capacitor with a withstand voltage that is 120% or more of the total of the rated output voltages of the RMX programmable power supplies that are connected in series.

## Connecting the Load (Series Operation)

**Figure 4-6.** Load Connection in Series Operation



Complete the following steps to connect the load.

1. Turn off all the RMX programmable power supplies that you want to connect in series.
2. Remove the OUTPUT terminal covers.
3. Use load cables to connect unit 1 and unit 2 to the load or relay terminal block.  
Use load cables that have sufficient current capacity. Wire the load cables so that they are as short as possible. If the voltage drop in the load cable is large, the difference in electric potential between power supply units and the load effect become large.
4. Connect the cables to the output terminals of unit 1 and unit 2.
5. Connect the output terminal (positive or negative) of unit 1 or unit 2 to the chassis terminal.
6. Attach the OUTPUT terminal cover.

## Settings (Series Operation)

### Setting the Voltage and Current

Set the voltage and current on each unit. The voltage that is output is the total of the voltages of the two units. Set the current to the same value on the two units.

### Setting the Overvoltage Protection (OVP) and Overcurrent Protection (OCP)

In series operation, you have to set the overvoltage protection (OVP) and overcurrent protection (OCP) on both units. Specify the same values on the two units.

## Starting (Series Operation)

### Turning the Power On and Off

Turn the POWER switch on unit 1 and unit 2 on or off.



**Caution** After you turn the POWER switch off, wait at least 10 seconds after the fan stops before you turn the POWER switch back on. Repeatedly turning the POWER switch on and off at short intervals can cause damage to the inrush current limiter. In turn, this will shorten the service life of the POWER switch, internal input fuse, and other components.

### Turning the Output On and Off

Press OUTPUT on unit 1 and unit 2 to turn the output on or off.



---

# Maintenance

This chapter explains how to perform calibration.

## Calibration Overview

---

The RMX power supply is calibrated before shipment and a factory calibration certificate can be obtained at <https://sine.ni.com/apps/utf8/nical.main>. To maintain long-term performance, NI recommends annual calibration. For calibration services, contact NI.

If you are going to calibrate RMX programmable power supplies yourself, follow the procedures below. All of the calibration items of the RMX programmable power supplies are described.

## Calibration Procedure

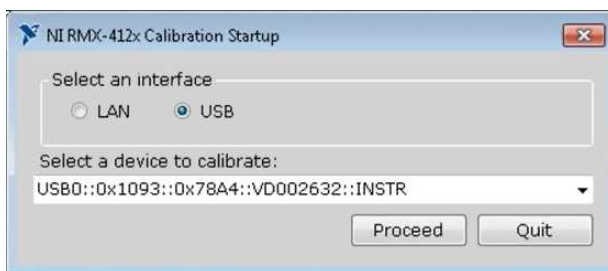
---

### Installation

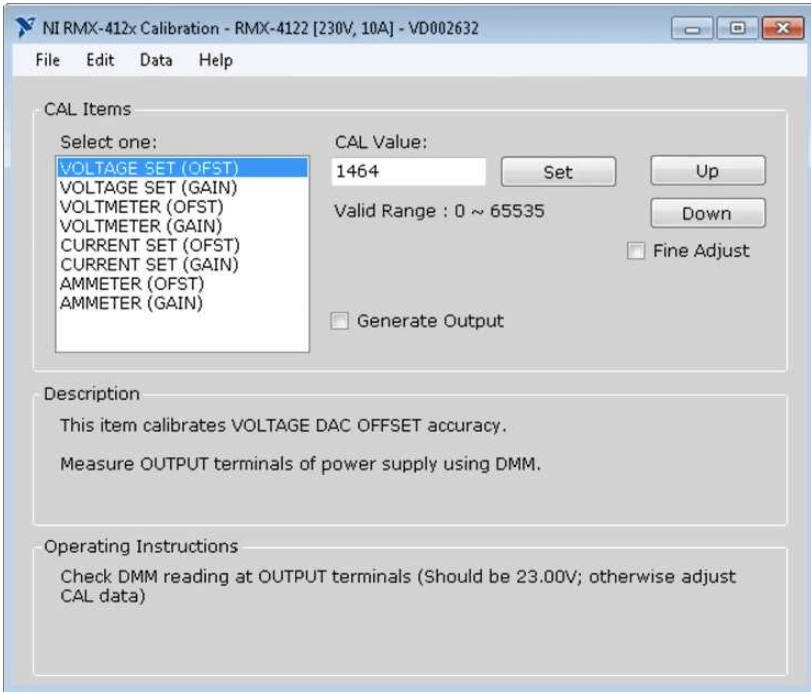
Launch `pxs_cal.exe` from the RMX Series zip folder.

### Launch

Turn on the instrument to be calibrated first, then launch the calibration program. What you see first is the application startup screen. You can select an I/O interface from LAN and USB.



Select one of interfaces, and an available VISA address string will be shown. Select it, and then click **Proceed**. The following main screen will appear:



## Calibration Items

There are eight calibration items where you should do in the specified order:

- VOLTAGE SET (OFST)
- VOLTAGE SET (GAIN)
- VOLTMETER SET (OFST)
- VOLTMETER SET (GAIN)
- CURRENT SET (OFST)
- CURRENT SET (GAIN)
- AMMETER SET (OFST)
- AMMETER SET (GAIN)

## Basic Instructions

- Select an item from the list, for instance VOLTAGE SET (OFST). Then, the existing CAL data (an integer value) will be shown at CAL Value area.
- At this point of time, the power supply output is off. Check the **Generate Output** checkbox to toggle the output.
- Check multimeter or instrument display (depending on the calibration item), then adjust calibration state by clicking **UP** or **DOWN** button.
- The **UP** and **DOWN** buttons increase or decrease the calibration value by 10 (coarse adjustment). You can check **Fine Adjust** for fine adjustment.
- You can also type a new calibration value in the text box and immediately set it by clicking the **SET** button.

## Save Calibration

- After calibration work is complete, the new calibration state is not yet saved in the instrument EEPROM. So you need commit EEPROM data.
- Select **Data»Commit EEPROM** menu. This operation immediately commits the EEPROM so that the new data is persistent after next power on.



**Note** If you do not commit EEPROM, the calibration will be restored to the previous state at the next power on.

## Backup Calibration Data to a XML File

- Select **File»Backup CAL Data to XML File**. Click the **Save As** dialog to save a new XML file.
- Click **OK** to save the existing calibration state to the specified XML file.

## Send Calibration Data from a XML File

- Select **File»Send CAL Data from XML File**. Click the **Open File** dialog to select an existing XML file with calibration data.
- Click **OK** to send the calibration data to the instrument.
- At this point of time, the calibration data is applied to the instrument, but not yet committed. So you need commit EEPROM for persistence.

## Revision History

### VER 1.0.0 (30 JULY 2016)

- The first public edition

### VER 0.9.0 BETA (23 MAY 2011)

- Evaluation Edition (developer use)

# System Requirements

## OS and Third Party Runtime

- Windows7 (x86/x64) is recommended. Vista (x86/x64) and XP-SP2 (x86) are also supported.
- Microsoft Visual C++ 2008 Run-Time Engine
- .NET Framework 2.0 or newer
- NI-VISA 15.0 or newer.

## Hardware Requirements

- A digital multimeter that has voltmeter function with 5.5 digits precision or higher.
- A shunt resistance that can flow the maximum DC current of your RMX power supply's current capacity.
- Load wires that can flow the maximum DC current.

**Table 5-1. Recommended Shunt Resistor**

Model	Rating	Tolerance
RMX-4120	100 A/50 mV (0.50 mΩ)	< ±0.1%
RMX-4121	30 A/50 mV (1.67 mΩ)	< ±0.1%
RMX-4122	10 A/50 mV (5 mΩ)	< ±0.1%
RMX-4123	5 A/50 mV (10 mΩ)	< ±0.1%
RMX-4124	150 A/50 mV (0.50 mΩ)	< ±0.1%
RMX-4125	100 A/50 mV (0.50 mΩ)	< ±0.1%
RMX-4126	20 A/50 mV (2.5 mΩ)	< ±0.1%
RMX-4127	10 A/50 mV (2.5 mΩ)	< ±0.1%

## Environment

Perform calibration in the following environment:

- Temperature: 23 °C ± 5 °C
- Humidity: 80% rh or less

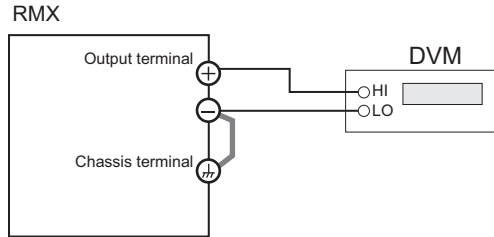
Warm up the RMX programmable power supply for at least 30 minutes before calibration. Also, ensure to warm up the DVM and shunt resistor for the duration listed in their documentation.

## Cleaning

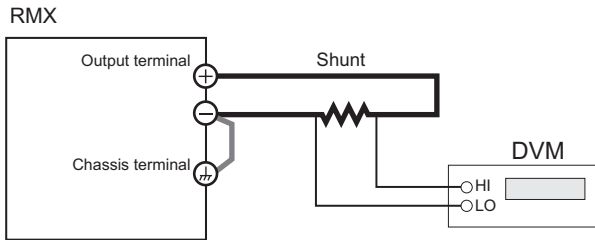
If the panel needs cleaning, gently wipe it using a soft cloth with water-diluted neutral detergent. Do not use volatile chemicals such as benzene or thinner.

# Connection

**Figure 5-1. Voltage Calibration**



**Figure 5-2. Current Calibration**



---

# Specifications

This appendix contains the specifications and dimensions for RMX programmable power supplies.

Unless specified otherwise, the specifications are for the following settings and conditions.

- Loads are pure resistive loads.
- The warm-up time is 30 minutes (with current flowing).
- After the RMX device has been warmed up, it must be calibrated correctly in a  $23\text{ }^{\circ}\text{C} \pm 5\text{ }^{\circ}\text{C}$  environment according to the procedures given in the operation manual.
- Values indicated by “TYP” are typical values. They are not guaranteed performance values.
- Values indicated by “rtg” are rated values.
- Values indicated by “rdng” are readout values.
- The RMX operates over a wide range of output voltage and output current within rated output power. However, the current that can be output with rated output voltage and the voltage that can be output with rated output current are limited by the rated output power.
- The current that can be output with rated output voltage and the voltage that can be output with rated output current are as follows.
  - Maximum output current with rated output voltage = Rated output power/rated output voltage.
  - Maximum output voltage with rated output current = Rated output power/rated output current.
- Rated load and no load are defined as follows:

In constant-voltage mode (when the output current is set to a value greater than or equal to the maximum output current with rated output voltage)

- **Rated load**—Refers to a resistive load that results in 95% to 100% of the maximum output current flowing when the output is set to the rated voltage level.
- **No load**—Refers to a load through which no output current flows. In other words, no load is connected.

In constant-current mode (when the output voltage is set to a value greater than or equal to the maximum output voltage with rated output current).

- **Rated load**—Refers to a resistive load that results in 95% to 100% of the maximum output voltage across the output terminals when the output is set to the rated current level. Including the voltage drop in the load cables, the RMX output voltage must not exceed the maximum output voltage with rated output current.

- **No load**—Refers to a resistive load that, when the rated output current flows, makes the voltage drop to 10% of the maximum output voltage with rated output current or 1 V whichever is higher.
- The specifications of the RMX programmable power supply apply to the rear panel output terminals.

## RMX-4120/4121/4122/4123

---

### AC Input

Nominal input rating .....	100 to 240 VAC, 50 to 60 Hz, single phase
Input voltage range .....	85 to 265 VAC
Input frequency .....	47 to 63 Hz
Current (MAX) <sup>1</sup>	
100 VAC .....	10.5 A
200 VAC .....	5.25 A
Inrush Current (MAX) <sup>2</sup> .....	70 A peak or less
Power (MAX) <sup>3</sup> .....	1100 VA
Power factor (TYP) <sup>1</sup> .....	0.99 (input voltage: 100 V), 0.97 (input voltage: 200 V)
Efficiency (MIN) <sup>1</sup> .....	74% or more
Hold-up time for power interruption (MIN) <sup>3</sup> .....	20 ms or greater

### DC Output

#### Rating

Output voltage <sup>4</sup>	
RMX-4120 .....	30 V
RMX-4121 .....	80 V
RMX-4122 .....	230 V
RMX-4123 .....	650 V
Output current <sup>4</sup>	
RMX-4120 .....	75 A
RMX-4121 .....	28 A
RMX-4122 .....	10 A
RMX-4123 .....	3.5 A

---

<sup>1</sup> With the rated load.

<sup>2</sup> Excludes the charge current component that flows through the capacitor of the internal EMC filter circuit immediately after the POWER switch is turned on (for approximately 1 ms).

<sup>3</sup> For all loads, with 100 VAC input.

<sup>4</sup> The maximum output voltage and current are limited by the maximum output power.

Output power .....	750 W
Voltage	
Setting range	
RMX-4120 .....	0 to 31.5 V
RMX-4121 .....	0 to 84 V
RMX-4122 .....	0 to 241.5 V
RMX-4123 .....	0 to 682.5 V
Setting accuracy .....	$\pm(0.05\%$ of setting $+0.05\%$ of rtg)
Line regulation <sup>1</sup>	
RMX-4120 .....	$\pm 5$ mV
RMX-4121 .....	$\pm 10$ mV
RMX-4122 .....	$\pm 25$ mV
RMX-4123 .....	$\pm 67$ mV
Load regulation <sup>2</sup>	
RMX-4120 .....	$\pm 5$ mV
RMX-4121 .....	$\pm 10$ mV
RMX-4122 .....	$\pm 25$ mV
RMX-4123 .....	$\pm 67$ mV
Transient response <sup>3</sup>	
RMX-4120/4121 .....	1 ms or less
RMX-4122/4123 .....	7 ms or less
Ripple noise	
(p-p) <sup>4</sup>	
RMX-4120 .....	60 mV
RMX-4121 .....	80 mV
RMX-4122 .....	120 mV
RMX-4123 .....	330 mV
(rms) <sup>5</sup>	
RMX-4120/4121 .....	8 mV
RMX-4122 .....	25 mV
RMX-4123 .....	60 mV
Rise time	
Rated load .....	100 ms
No load .....	100 ms

<sup>1</sup> 85 VAC to 135 VAC or 170 VAC to 265 VAC, fixed load.

<sup>2</sup> The amount of change that occurs when the load is changed from no load to rated load (rated output power/rated output voltage) with rated output voltage. The value is measured at the sensing point.

<sup>3</sup> The amount of time required for the output voltage to return to a value within “rated output voltage  $\pm$  (0.1% +10 mV).” The load current fluctuation is 50% to 100% of the maximum current with the set output voltage.

<sup>4</sup> When the measurement frequency bandwidth is 10 Hz to 20 MHz.

<sup>5</sup> When the measurement frequency bandwidth is 10 Hz to 1 MHz.



Fall time<sup>1</sup>

Rated load

RMX-4120/4121 .....	100 ms
RMX-4122 .....	150 ms
RMX-4123 .....	250 ms

No load

RMX-4120/4121 .....	450 ms
RMX-4122 .....	1500 ms
RMX-4123 .....	3000 ms

Maximum remote sensing compensation voltage (single line)

RMX-4120 .....	1.5 V
RMX-4121 .....	4 V
RMX-4122/RMX-4123 .....	5 V

Temperature coefficient (MAX)<sup>2</sup>..... 100 ppm/°C (during external control)

Current

Setting range

RMX-4120 .....	0 to 78.75 A
RMX-4121 .....	0 to 29.4 A
RMX-4122 .....	0 to 10.5 A
RMX-4123 .....	0 to 3.675 A

Setting accuracy.....±(0.5% of setting +0.1% of rtg)

Line regulation

RMX-4120 .....	± 9.5 mA
RMX-4121 .....	± 4.8 mA
RMX-4122 .....	±3 mA
RMX-4123 .....	±2.35 mA

Load regulation

RMX-4120 .....	± 20 mA
RMX-4121 .....	±10.6 mA
RMX-4122 .....	±7 mA
RMX-4123 .....	±5.7 mA

Ripple noise<sup>3</sup>

(rms)<sup>4</sup>

RMX-4120 .....	150 mA
RMX-4122 .....	65 mA
RMX-4122 .....	30 mA
RMX-4123 .....	15 mA

Temperature coefficient (TYP)<sup>1</sup>..... 100 ppm/°C

<sup>1</sup> When the bleeder circuit is on.

<sup>2</sup> When the ambient temperature is within 0 to 50 °C.

<sup>3</sup> When the output voltage is 10% to 100% of the rating. At the rated output current.

<sup>4</sup> When the measurement frequency bandwidth is 10 Hz to 1 MHz.

## Display Function

### Voltage display

#### Maximum display

RMX-4120/4121 ..... 99.99 (fixed decimal point)

RMX-4122/4123 ..... 999.9 (fixed decimal point)

Display accuracy .....  $\pm(0.2\%$  of rdng +5 digits)

### Current display

#### Maximum display

RMX-4120/4121/4122 ..... 99.99 (fixed decimal point)

RMX-4123 ..... 9.999 (fixed decimal point)

Display accuracy .....  $\pm(0.5\%$  of rdng +5 digits)

Power display<sup>1</sup> ..... The PWR DSPL key lights in red.

Maximum display ..... 9999

### Operation display

OUTPUT ON/OFF ..... Output on: OUTPUT LED lights green.  
 Output off: OUTPUT LED turns off.  
 The output is on and a protection function has been activated: OUTPUT LED blinks orange.

CV operation ..... CV LED lights green

CC operation ..... CC LED lights red

Alarm operation ..... ALM LED lights red when a protection function has been activated.

ALM LED blinks red when the power limit (POWER LIMIT) has been activated.

Remote operation ..... REMOTE LED lights green during remote control.

LAN operation ..... LAN LED lights or blinks depending on the LAN communication status.

No fault status: Lights green.

Fault status: Lights red.

Standby status: Lights orange.

WEB identify status: Blinks green.

Key lock operation ..... LOCK LED lights green when the keys are locked.

Preset memory ..... When a preset memory entry is being used, the PRESET A, B, or C LED lights green.

---

<sup>1</sup> Press PWR DSPL to display the power on the ammeter. Each time you press this key, the display switches between power and current.

## Protection Functions

Overvoltage protection (OVP).....	Turns the output off, displays OVP, and lights ALARM
Setting range <sup>1</sup>	
RMX-4120 .....	3 to 33.6 V
RMX-4121 .....	8 to 89.6 V
RMX-4122 .....	23 to 257.6 V
RMX-4123 .....	65 to 728.0 V
Setting accuracy .....	±(1.5% of rtg)
Overvoltage protection 2 (OVP2).....	Turns the output off, displays OVP2, and lights ALARM
Value (fixed)	
RMX-4120 .....	36 V (120% of the rated output voltage)
RMX-4121 .....	96 V (120% of the rated output voltage)
RMX-4122 .....	276 V (120% of the rated output voltage)
RMX-4121 .....	780 V (120% of the rated output voltage)
Overcurrent protection (OCP) <sup>2</sup> .....	Turns the output off, displays OCP, and lights ALARM
Setting range <sup>3</sup>	
RMX-4120 .....	7.5 to 84 A
RMX-4121 .....	2.8 to 31.36 A
RMX-4122 .....	1 to 11.2 A
RMX-4123 .....	0.35 to 3.92 A
Setting accuracy .....	±(3% of rtg)
Undervoltage limit (UVL) .....	Output voltage cannot be set to a value less than or equal to the UVL voltage
Setting range <sup>4</sup>	
RMX-4120 .....	0 to 31.5 V
RMX-4121 .....	0 to 84 V
RMX-4122 .....	0 to 241.5 V
RMX-4123 .....	0 to 682.5 V

---

<sup>1</sup> (10% to 112% of the rated output voltage)

<sup>2</sup> This does not protect against the discharge current peak that is generated from the capacitors inside the RMX output section when the load is changed suddenly.

<sup>3</sup> (10% to 112% of the rated output current)

<sup>4</sup> (0 to 105% of the rated output voltage)

Overheat protection (OHP).....	Turns the output off <sup>1</sup> , displays OHP, and lights ALARM
Overheat protection2 (OHP2).....	Turns the output off, displays OHP2, and lights ALARM
Fan failure protection (FAN).....	Turns the output off <sup>1</sup> , displays FAN, and lights ALARM
Incorrect sensing connection protection (SENSE).....	Turns the output off, displays SENS, and lights ALARM
Low AC input protection (AC-FAIL) .....	Turns the output off <sup>1</sup> , displays AC, and lights ALARM
Shutdown (SD).....	Turns the output off, displays SD, and lights ALARM
Power limit (POWER LIMIT).....	Blinks ALARM
Value (fixed) .....	787.5 (approximately 105% of the rated output power)
Communication monitoring (WATCHDOG)...	Turns the output off, displays DOG, and lights ALARM

## Signal Output

### Monitor signal output<sup>2</sup>

Voltage monitor (VMON).....	Selectable monitor voltage range: 0 to 5 V or 0 to 10 V
Setting accuracy.....	2.5% of rtg
Current monitor (IMON).....	Selectable monitor voltage range: 0 to 5 V or 0 to 10 V
Setting accuracy.....	2.5% of rtg

### Status signal output<sup>3</sup>

OUTON STATUS .....	Turns on when the output is on
CV STATUS.....	Turns on during CV operation
CC STATUS.....	Turns on during CC operation
ALM STATUS .....	Turns on when an alarm has been activated
PWR ON STATUS.....	Turns on when the power is turned on

---

<sup>1</sup> Use the CONFIG settings to specify what happens when a protection function is activated and the output is turned off. You can select to turn the output on automatically when the problem that caused the alarm is fixed (CF03: Auto) or to leave the output turned off when the problem that caused the alarm is fixed (CF03:SAFE). The specified protection operation is the same for the OHP, FAN, and AC-FAIL alarms. You cannot make separate settings for the OHP, FAN, and AC-FAIL alarms.

<sup>2</sup> J1 connector on the rear panel.

<sup>3</sup> J2 connector on the rear panel. Photocoupler open collector output; maximum voltage 30 V, maximum current (sink) 8 mA; isolated from the output and control circuits; status commons are floating (withstand voltage of less than or equal to 60 V); and status signals are not mutually isolated.

## Control Features

### External control<sup>1</sup>

Output voltage control (VPGM) .....	0 to 100% of the rated output voltage. Selectable control voltage range: 0 to 5 V or 0 to 10 V
Accuracy .....	5% of rtg
Output current control (IPGM) .....	0 to 100% of the rated output current. Selectable control voltage range: 0 to 5 V or 0 to 10 V
Accuracy .....	5% of rtg
Output on/off control	
OUTPUT ON/OFF CONT .....	Possible logic selections: Turn the output on using a LOW (0 to 0.5 V) or short-circuit, turn the output off using a HIGH (4.5 to 5 V) or open-circuit. Turn the output on using a HIGH (4.5 to 5 V) or open-circuit, turn the output off using a LOW (0 to 0.5 V) or short-circuit.
Output shutdown control	
SHUT DOWN .....	Turns the output off with a LOW (0 to 0.5 V) or short-circuit.
Alarm clear control ALM CLR .....	Clears alarms with a LOW (0 to 0.5 V) or short-circuit.

## Other Features

Master-slave parallel operation .....	Including the master unit, up to four units (all the same model) can be connected (excluding the RMX-4123).
Series operation <sup>2</sup> .....	Up to two units (all the same model) can be connected.
Preset memory .....	Up to three sets of the following settings can be saved: the set voltage, the set current, the set OVP, the set OCP, and the set UVL.
Key lock .....	Locks the operation of all keys other than the OUTPUT key.
Multichannel (VMCB)	
Between master unit and PC .....	LAN, USB, RS232C
Slave unit .....	LAN

---

<sup>1</sup> J1 connector on the rear panel.

<sup>2</sup> Excluding the RMX-4123.

## Interface

### Common specifications

Software protocol .....	IEEE Std 488.2-1992
Command language .....	Complies with SCPI Specification 1999.0 Has a compatibility mode (switchable) <sup>1</sup> . Genesys series made by TDK-Lambda. N5700 and N8700 made by Agilent Technologies. DSC series made by Sorensen. PAG series made by Kikusui.

### RS232C

Hardware .....	Complies with the EIA232D specifications (excluding the connector) RJ-45 connector <sup>2</sup> Baud rate: 1200, 2400, 4800, 9600, 19200, 38400, 57600, and 115200 bps Data length: 8 bits, Stop bits: 1 bit, Parity bit: None No flow control
Program message terminator .....	LF during reception, CR/LF during transmission

### USB

Hardware .....	Complies with the USB 2.0 specifications. Baud rate: 480 Mbps (high speed). Socket B type
Program message terminator .....	LF or EOM during reception, LF + EOM during transmission
Device class .....	Complies with the USBTMC-USB488 device class specifications

### LAN

Hardware .....	IEEE 802.3 100Base-TX or 10Base-T Ethernet IPv4, RJ-45 connector <sup>2</sup>
Communication protocol .....	VXI-11, HiSLIP, or SCPI-RAW
Program message terminator .....	VXI-11 and HiSLIP: LF or END during reception, LF + END during transmission SCPI-RAW: LF during reception, LF during transmission

---

<sup>1</sup> This setting does not guarantee compatibility with all measuring instrument application software and drivers.

<sup>2</sup> Category 5; use a straight cable.

## General

### Weight

RMX-4120/4121 .....	Approximately 8 kg (17.64 lb)
RMX-4122/4123 .....	Approximately 7.5 kg (16.53 lb)

Cooling method..... Forced air cooling using fan

### Environmental conditions

Operating environment .....	Indoor use, overvoltage category II
Operating temperature .....	0 to 50 °C (32 to 122 °F)
Operating humidity .....	20 to 85% rh (no condensation)
Storage temperature .....	-10 to 60 °C (14 to 140 °F)
Storage humidity .....	90% rh or less (no condensation)
Altitude .....	Up to 2,000 m
Pollution degree .....	2 <sup>1</sup>

Grounding polarity..... Negative grounding or positive grounding possible<sup>2</sup>

### Isolation voltage

RMX-4120/4121 .....	±250 Vmax
RMX-4122 .....	±500 Vmax
RMX-4123 .....	±600 Vmax

### Withstand voltage

Between input and FG .....	No abnormalities at 1500 VAC for 1 minute
Between input and output	
RMX-4120/4121/4122 .....	No abnormalities at 2000 VAC for 1 minute
RMX-4123 .....	No abnormalities at 2250 VAC for 1 minute
Between output and FG	
RMX-4120/4121 .....	No abnormalities at 1500 VDC for 1 minute
RMX-4122 .....	No abnormalities at 1600 VDC for 1 minute
RMX-4123 .....	No abnormalities at 2000 VDC for 1 minute

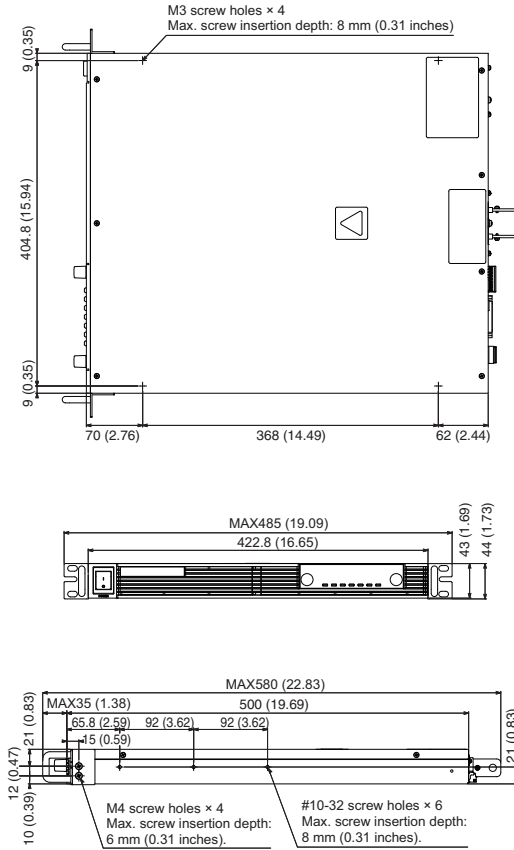
### Insulation resistance

Between input and FG .....	±500 Vdc, 100 MΩ or more (70% or less)
Between input and output	
RMX-4120/4121/4122 .....	±500 VDC, 100 MΩ or more (70% or less)
RMX-4123 .....	±1000 VDC, 100 MΩ or more (70% or less)
Between output and FG	
RMX-4120/4121/4122 .....	±500 VDC, 40 MΩ or more (70% or less)
RMX-4123 .....	±1000 VDC, 40 MΩ or more (70% or less)

<sup>1</sup> Pollution is addition of foreign matter (solid, liquid or gaseous) that may produce a reduction of dielectric strength or surface resistivity. Pollution Degree 2 assumes that only non-conductive pollution will occur except for an occasional temporary conductivity caused by condensation.

<sup>2</sup> Confirm the RMX-4123 is not grounded when it generates greater than 600 V.

**Figure A-1. RMX-4120/4121/4122/4123 Dimensions**





# RMX-4124/4125/4126/4127

---

## AC Input

Nominal input rating .....	100 to 240 VAC, 50 to 60 Hz, single phase
Input voltage range .....	85 to 265 VAC
Input frequency .....	47 to 63 Hz
Current (MAX) <sup>1</sup>	
100 VAC .....	21 A
200 VAC .....	10.5 A
Inrush Current (MAX) <sup>2</sup> .....	70 A peak or less
Power (MAX) <sup>3</sup> .....	2200 VA
Power factor (TYP) <sup>1</sup> .....	0.99 (input voltage: 100 V), 0.97 (input voltage: 200 V)
Efficiency (MIN) <sup>1</sup> .....	74% or more
Hold-up time for power interruption (MIN) <sup>3</sup> .....	20 ms or greater

## DC Output

### Rating

Output voltage <sup>4</sup>	
RMX-4124 .....	0 to 30 V
RMX-4125 .....	0 to 80 V
RMX-4126 .....	0 to 230 V
RMX-4127 .....	0 to 650 V
Output current <sup>4</sup>	
RMX-4124 .....	150 A
RMX-4125 .....	56 A
RMX-4126 .....	20 A
RMX-4127 .....	7 A
Output power .....	1500 W

### Voltage

Setting range	
RMX-4124 .....	0 to 31.5 V
RMX-4125 .....	0 to 84 V

---

<sup>1</sup> With the rated load.

<sup>2</sup> Excludes the charge current component that flows through the capacitor of the internal EMC filter circuit immediately after the POWER switch is turned on (for approximately 1 ms).

<sup>3</sup> For all loads, with 100 VAC input.

<sup>4</sup> The maximum output voltage and current are limited by the maximum output power.

RMX-4126.....	0 to 241.5 V
RMX-4127.....	0 to 682.5 V
Setting accuracy.....	±(0.05% of set +0.05% of rtg)
Line regulation <sup>1</sup>	
RMX-4124.....	±5 mV
RMX-4125.....	±10 mV
RMX-4126.....	±25 mV
RMX-4127.....	±67 mV
Load regulation <sup>2</sup>	
RMX-4124.....	±5 mV
RMX-4125.....	±10 mV
RMX-4126.....	±25 mV
RMX-4127.....	±67 mV
Transient response <sup>3</sup>	
RMX-4124/4125.....	1 ms or less
RMX-4126/4127.....	7 ms or less
Ripple noise	
(p-p) <sup>4</sup>	
RMX-4124.....	60 mV
RMX-4125.....	80 mV
RMX-4126.....	120 mV
RMX-4127.....	330 mV
(rms) <sup>5</sup>	
RMX-4124/4125.....	8 mV
RMX-4126.....	25 mV
RMX-4127.....	60 mV
Rise time	
Rated load.....	100 ms
No load.....	100 ms
Fall time <sup>6</sup>	
Rated load	
RMX-4124/4125.....	100 ms

<sup>1</sup> 85 VAC to 135 VAC or 170 VAC to 265 VAC, fixed load.

<sup>2</sup> The amount of change that occurs when the load is changed from no load to rated load (rated output power/rated output voltage) with rated output voltage. The value is measured at the sensing point.

<sup>3</sup> The amount of time required for the output voltage to return to a value within “rated output voltage ± (0.1% +10 mV).” The load current fluctuation is 50% to 100% of the maximum current with the set output voltage.

<sup>4</sup> When the measurement frequency bandwidth is 10 Hz to 20 MHz.

<sup>5</sup> When the measurement frequency bandwidth is 10 Hz to 1 MHz.

<sup>6</sup> When the bleeder circuit on/off setting is on.

RMX-4126 .....	150 ms
RMX-4127 .....	250 ms

No load

RMX-4124/4125 .....	800 ms
RMX-4126 .....	1500 ms
RMX-4127 .....	3000 ms

Maximum remote sensing compensation voltage (single line)

RMX-4124 .....	1.5 V
RMX-4125 .....	4 V
RMX-4126/4127 .....	5 V

Temperature coefficient (MAX)<sup>1</sup> ..... 100 ppm/°C (during external control)

Current

Setting range

RMX-4124 .....	0 to 157.5 A
RMX-4125 .....	0 to 58.8 A
RMX-4126 .....	0 to 21 A
RMX-4127 .....	0 to 7.35 A

Setting accuracy<sup>2</sup> ..... ±(0.5% of set +0.1% of rtg)

Line regulation

RMX-4124 .....	±17 mA
RMX-4125 .....	±7.6 mA
RMX-4126 .....	±4 mA
RMX-4127 .....	±2.7 mA

Load regulation

RMX-4124 .....	±35 mA
RMX-4125 .....	±16.2 mA
RMX-4126 .....	±9 mA
RMX-4127 .....	±6.4 mA

Ripple noise<sup>3</sup>(rms)<sup>4</sup>

RMX-4124 .....	300 mA
RMX-4125 .....	130 mA
RMX-4126 .....	60 mA
RMX-4127 .....	30 mA

Temperature coefficient (TYP)<sup>1</sup> ..... 100 ppm/°C

<sup>1</sup> When the ambient temperature is within 0 and 50°C.

<sup>2</sup> For the RMX-4124 and RMX-4125, in the range of 1% to 100% of the rated current.  
For the RMX-4127, in the range of 0.2% to 100% of the rated current.

<sup>3</sup> When the output voltage is 10% to 100% of the rating. At the rated output current.

<sup>4</sup> When the measurement frequency bandwidth is 10 Hz to 1 MHz.

## Display Function

### Voltage display

#### Maximum display

RMX-4124.....	99.99 (fixed decimal point)
RMX-4125.....	99.99 (fixed decimal point)
RMX-4126.....	999.9 (fixed decimal point)
RMX-4127.....	999.9 (fixed decimal point)

Display accuracy.....  $\pm(0.2\%$  of rdng +5 digits)

### Current display

#### Maximum display

RMX-4124.....	999.9 (fixed decimal point)
RMX-4125.....	99.99 (fixed decimal point)
RMX-4126.....	99.99 (fixed decimal point)
RMX-4127.....	9.999 (fixed decimal point)

Display accuracy.....  $\pm(0.5\%$  of rdng +5 digits)

Power display<sup>1</sup>..... The PWR DSPL key lights red.

Maximum display..... 9999

### Operation display

OUTPUT ON/OFF .....	Output on: OUTPUT LED lights green. Output off: OUTPUT LED turns off. The output is on and a protection function has been activated: OUTPUT LED blinks orange.
CV operation.....	CV LED lights green
CC operation.....	CC LED lights red
Alarm operation.....	ALM LED lights red when a protection function has been activated. ALM LED blinks red when the power limit (POWER LIMIT) has been activated.
Remote operation.....	REMOTE LED lights green during remote control.
LAN operation.....	LAN LED lights or blinks depending on the LAN communication status. No fault status: Lights green. Fault status: Lights red. Standby status: Lights orange. WEB identify status: Blinks green.
Key lock operation.....	LOCK LED lights in green when the keys are locked.
Preset memory .....	When a preset memory entry is being used, the PRESET A, B, or C LED lights in green.

---

<sup>1</sup> Press PWR DSPL to display the power on the ammeter. Each time you press this key, the display switches between power and current.

## Protection Functions

Overvoltage protection (OVP).....	Turns the output off, displays OVP, and lights ALARM
Setting range	
RMX-4124 .....	3 to 33.6 V (10% to 112% of the rated output voltage)
RMX-4125 .....	8 to 89.6 V (10% to 112% of the rated output voltage)
RMX-4126 .....	23 to 257.6 V (10% to 112% of the rated output voltage)
RMX-4127 .....	65 to 782 V (10% to 112% of the rated output voltage)
Setting accuracy .....	±(1.5% of rtg)
Overvoltage protection 2 (OVP2).....	Turns the output off, displays OVP2, and lights ALARM
Value (fixed)	
RMX-4124 .....	36 V (120% of the rated output current)
RMX-4125 .....	96 V (120% of the rated output current)
RMX-4126 .....	276 V (120% of the rated output current)
RMX-4127 .....	780 V (120% of the rated output current)
Overcurrent protection (OCP) <sup>1</sup> .....	Turns the output off, displays OCP, and lights ALARM
Setting range	
RMX-4124 .....	15 to 168 A (10% to 112% of the rated output current)
RMX-4125 .....	5.6 to 62.72 A (10% to 112% of the rated output current)
RMX-4126 .....	2 to 22.4 A (10% to 112% of the rated output current)
RMX-4127 .....	0.7 to 7.84 A (10% to 112% of the rated output current)
Setting accuracy .....	±(3% of rtg)
Undervoltage limit (UVL) .....	Output voltage cannot be set to a value less than or equal to the UVL voltage
Setting range	
RMX-4124 .....	0 to 31.5 V (0 to 105% of the rated output voltage)
RMX-4125 .....	0 to 84 V (0 to 105% of the rated output voltage)
RMX-4126 .....	0 to 241.5 V (0 to 105% of the rated output voltage)
RMX-4127 .....	0 to 682.5 V (0 to 105% of the rated output voltage)

---

<sup>1</sup> This does not protect against the discharge current peak that is generated from the capacitors inside the RMX output section when the load is changed suddenly.

Overheat protection (OHP).....	Turns the output off <sup>1</sup> , displays OHP, and lights ALARM
Overheat protection2 (OHP2).....	Turns the output off, displays OHP2, and lights ALARM
Fan failure protection (FAN).....	Turns the output off <sup>1</sup> , displays FAN, and lights ALARM
Incorrect sensing connection protection (SENSE).....	Turns the output off, displays SENS, and lights ALARM
Low AC input protection (AC-FAIL) .....	Turns the output off <sup>1</sup> , displays AC, and lights ALARM
Shutdown (SD) .....	Turns the output off, displays SD, and lights ALARM
Power limit (POWER LIMIT).....	Blinks ALARM
Value (fixed).....	1575.0 (approximately 105% of the rated output power)
Communication monitoring (WATCHDOG)...	Turns the output off, displays DOG, and lights ALARM

## Signal Output

### Monitor signal output<sup>2</sup>

Voltage monitor (VMON).....	Selectable monitor voltage range: 0 to 5 V or 0 to 10 V
Setting accuracy.....	2.5% of rtg
Current monitor (IMON).....	Selectable monitor voltage range: 0 to 5 V or 0 to 10 V
Setting accuracy.....	2.5% of rtg

### Status signal output<sup>3</sup>

OUTON STATUS .....	Turns on when the output is on
CV STATUS.....	Turns on during CV operation
CC STATUS.....	Turns on during CC operation
ALM STATUS .....	Turns on when an alarm has been activated
PWR ON STATUS.....	Turns on when the power is turned on

---

<sup>1</sup> Use the CONFIG settings to specify what happens when a protection function is activated and the output is turned off. You can select to turn the output on automatically when the problem that caused the alarm is fixed (CF03: Auto) or to leave the output turned off when the problem that caused the alarm is fixed (CF03:SAFE). The specified protection operation is the same for the OHP, FAN, and AC-FAIL alarms. You cannot make separate settings for the OHP, FAN, and AC-FAIL alarms.

<sup>2</sup> J1 connector on the rear panel.

<sup>3</sup> J2 connector on the rear panel. Photocoupler open collector output; maximum voltage 30 V, maximum current (sink) 8 mA; isolated from the output and control circuits; status commons are floating (withstand voltage of less than or equal to 60 V); and status signals are not mutually isolated.

## Control Features

### External control<sup>1</sup>

Output voltage control (VPGM) .....	0 to 100% of the rated output voltage. Selectable control voltage range: 0 to 5 V or 0 to 10 V
Accuracy .....	5% of rtg
Output current control (IPGM) .....	0 to 100% of the rated output current. Selectable control voltage range: 0 to 5 V or 0 to 10 V
Accuracy .....	5% of rtg
Output on/off control	
OUTPUT ON/OFF CONT .....	Possible logic selections: Turn the output on using a LOW (0 to 0.5 V) or short-circuit, turn the output off using a HIGH (4.5 to 5 V) or open-circuit. Turn the output on using a HIGH (4.5 to 5 V) or open-circuit, turn the output off using a LOW (0 V to 0.5 V) or short-circuit.
Output shutdown control	
SHUT DOWN .....	Turns the output off with a LOW (0 to 0.5 V) or short-circuit.
Alarm clear control ALM CLR .....	Clears alarms with a LOW (0 to 0.5 V) or short-circuit.

## Other Features

Master-slave parallel operation .....	Including the master unit, up to four units (all the same model) can be connected.
Series operation <sup>2</sup> .....	Up to two units (all the same model) can be connected.
Preset memory .....	Up to three sets of the following settings can be saved: the set voltage, the set current, the set OVP, the set OCP, and the set UVL.
Key lock .....	Locks the operation of all keys other than the OUTPUT key.
Multichannel (VMCB)	
Between master unit and PC .....	LAN, USB, RS232C
Slave unit .....	LAN

---

<sup>1</sup> J1 connector on the rear panel

<sup>2</sup> Excluding the RMX-4127

## Interface

### Common specifications

Software protocol .....	IEEE Std 488.2-1992
Command language .....	Complies with SCPI Specification 1999.0 Has a compatibility mode (switchable) <sup>1</sup> . Genesys series made by TDK-Lambda. N5700 and N8700 made by Agilent Technologies. DSC series made by Sorensen. PAG series made by Kikusui.

### RS232C

Hardware .....	Complies with the EIA232D specifications (excluding the connector) RJ-45 connector <sup>2</sup> Baud rate: 1200, 2400, 4800, 9600, 19200, 38400, 57600, and 115200 bps Data length: 8 bits, Stop bits: 1 bit, Parity bit: None No flow control
Program message terminator .....	LF during reception, CR/LF during transmission

### USB

Hardware .....	Complies with the USB 2.0 specifications. Baud rate: 480 Mbps (high speed). Socket B type
Program message terminator .....	LF or EOM during reception, LF + EOM during transmission
Device class .....	Complies with the USBTMC-USB488 device class specifications

### LAN

Hardware .....	IEEE 802.3 100Base-TX or 10Base-T Ethernet IPv4, RJ-45 connector
Communication protocol .....	VXI-11, HiSLIP, or SCPI-RAW
Program message terminator .....	VXI-11 and HiSLIP: LF or END during reception, LF + END during transmission SCPI-RAW: LF during reception, LF during transmission

---

<sup>1</sup> This setting does not guarantee compatibility with all measuring instrument application software and drivers.

<sup>2</sup> Category 5; use a straight cable.



## General

### Weight

RMX-4124/4125 .....	Approximately 9.5 kg (20.94 lb)
RMX-4126/4127 .....	Approximately 9.0 kg (19.84 lb)

### Environmental conditions

Operating environment .....	Indoor use, overvoltage category II
Operating temperature .....	0 to 50 °C (32 to 122 °F)
Operating humidity .....	20 to 85% rh (no condensation)
Storage temperature .....	-10 to 60 °C (14 to 140 °F)
Storage humidity .....	90% rh or less (no condensation)
Altitude .....	Up to 2,000 m
Pollution degree .....	2

Cooling method..... Forced air cooling using fan

Grounding polarity..... Negative grounding or positive grounding possible<sup>1</sup>

### Isolation voltage

RMX-4124/4125 .....	±250 Vmax
RMX-4126 .....	±500 Vmax
RMX-4127 .....	±600 Vmax

### Withstand voltage

Between input and FG .....	No abnormalities at 1500 Vac for 1 minute
Between input and output	
RMX-4124/4125/4126 .....	No abnormalities at 2000 Vac for 1 minute
RMX-4127 .....	No abnormalities at 2250 Vac for 1 minute
Between output and FG	
RMX-4124/4125 .....	No abnormalities at 1500 Vdc for 1 minute
RMX-4126 .....	No abnormalities at 1600 Vdc for 1 minute
RMX-4127 .....	No abnormalities at 2000 Vdc for 1 minute

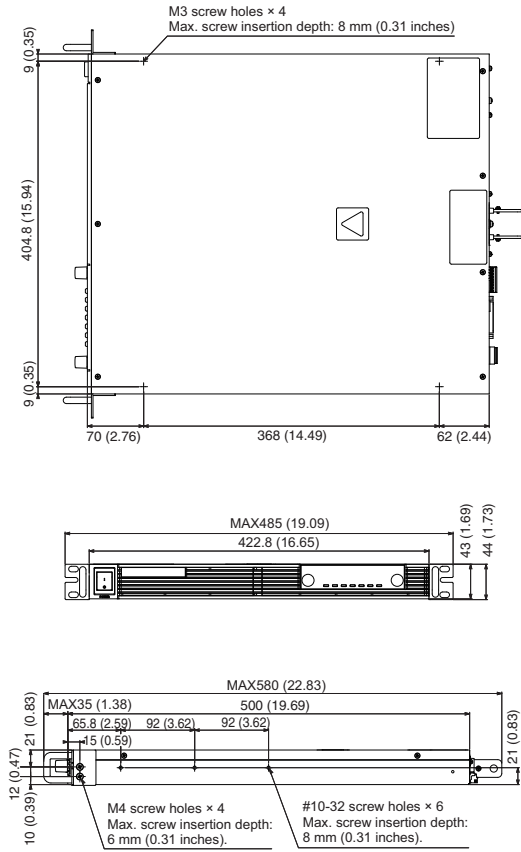
### Insulation resistance

Between input and FG .....	±500 Vdc, 100 MΩ or more (70% or less)
Between input and output	
RMX-4124/4125/4126 .....	±500 Vdc, 100 MΩ or more (70% or less)
RMX-4127 .....	±1000 Vdc, 100 MΩ or more (70% or less)
Between output and FG	
RMX-4124/4125/4126 .....	±500 Vdc, 40 MΩ or more (70% or less)
RMX-4127 .....	±1000 Vdc, 40 MΩ or more (70% or less)

---

<sup>1</sup> Confirm the RMX-4127 is not grounded when it generates greater than 600 V.

**Figure A-2. RMX-4124/4125/4126/4127 Dimensions**



## Safety

This product is designed to meet the requirements of the following standards of safety for electrical equipment for measurement, control, and laboratory use:

- IEC/EN 61010-1
- UL 61010-1
- CSA C22.2 No. 61010-1



**Note** For safety certifications, refer to the product label or the [Online Product Certification](#) section.

## Electromagnetic Compatibility

This product meets the requirements of the following EMC standards for electrical equipment for measurement, control, and laboratory use:

- EN 61326-1 (IEC 61326-1): Class A emissions; Basic immunity
- EN 55011 (CISPR 11): Group 1, Class A emissions

## AS/NZS CISPR 11: Group 1, Class A emissions

---

- FCC 47 CFR Part 15B: Class A emissions
- ICES-001: Class A emissions



**Note** In the United States (per FCC 47 CFR), Class A equipment is intended for use in commercial, light industrial, and heavy industrial locations. In Europe, Canada, Australia, and New Zealand (per CISPR 11), Class A equipment is intended for use only in heavy industrial locations.



**Note** Group 1 equipment (per CISPR 11) is any industrial, scientific, or medical equipment that does not intentionally generate radio frequency energy for the treatment of material or inspection/analysis purposes.



**Note** For EMC declarations and certifications and additional information, refer to the [Online Product Certification](#) section.

## CE Compliance

This product meets the essential requirements of applicable European Directives as follows:

- 2014/35/EU; Low-Voltage Directive (safety)
- 2014/30/EU; Electromagnetic Compatibility Directive (EMC)
- 2011/65/EU; RoHS

## Online Product Certification

Refer to the product Declaration of Conformity (DoC) for additional regulatory compliance information. To obtain product certifications and the DoC for this product, visit [ni.com/certification](http://ni.com/certification), search by model number or product line, and click the appropriate link in the Certification column.

## Environmental Management

NI is committed to designing and manufacturing products in an environmentally responsible manner. NI recognizes that eliminating certain hazardous substances from our products is beneficial to the environment and to NI customers.

For additional environmental information, refer to the *Minimize Our Environmental Impact* web page at [ni.com/environment](http://ni.com/environment). This page contains the environmental regulations and directives with which NI complies, as well as other environmental information not included in this document.

## Waste Electrical and Electronic Equipment (WEEE)



**EU Customers** At the end of the product life cycle, all products *must* be sent to a WEEE recycling center. For more information about WEEE recycling centers, National Instruments WEEE initiatives, and compliance with WEEE Directive 2002/96/EC on Waste and Electronic Equipment, visit [ni.com/environment/weee](http://ni.com/environment/weee).

## 电子信息产品污染控制管理办法（中国 RoHS）



**中国客户** National Instruments 符合中国电子信息产品中限制使用某些有害物质指令 (RoHS)。关于 National Instruments 中国 RoHS 合规性信息, 请登录 [ni.com/environment/rohs\\_china](http://ni.com/environment/rohs_china)。(For information about China RoHS compliance, go to [ni.com/environment/rohs\\_china](http://ni.com/environment/rohs_china).)

---

# Troubleshooting

This appendix lists a few troubleshooting situations and their corresponding solutions.

If none of the items apply to your case, we recommend that you initialize the RMX programmable power supply to its factory default settings by holding down the SHIFT + LOCAL keys while turning the power switch on. If this does not correct the problem, contact National Instruments.

## The Power Does Not Turn On

---

**The RMX programmable power supply does not operate when the POWER switch is turned on.**

Is the power cord broken? Exchange the power cord with a new one.

Is the power cord connected correctly? Connect the power cord correctly.

## No Output is Generated

---

**No output is generated even when the OUTPUT switch is turned on.**

Is the output voltage set to 0 V and the output current set to 0 A? Turn the knobs to set the output voltage and output current to the required values.

Are you using an external contact to turn output on and off? Use the external contact to turn output on. If not, set the external control parameter for turning output on and off to “off” (CF09: oFF).

**Even when the RMX programmable power supply is configured so that output is turned on at power on, the output is turned off immediately after the power is turned on.**

Has the overvoltage protection (OVP) function been activated? Limit the set output voltage (CF15: on). If you do not limit the set output voltage (CF15: oFF), set the OVP to a value that is higher than the set voltage.

Has the overvoltage protection2 (OVP2) function been activated? A voltage that is greater than or equal to the rated output may be being applied to the RMX programmable power supply. Check the voltage that is being applied.

Has the overheat protection (OHP/ OHP2) function been activated? The internal temperature is abnormally high. Check the operating conditions. After you have removed the cause of the

abnormal temperature, turn the power switch on. The air inlet may be clogged, or the fan may be broken. Check them.

Is a shutdown (SD) signal being applied? Set pin 6 of the J1 connector to HIGH (4.5 to 5 V) or open the pin, or eliminate the shutdown (SD) signal.

## Unable to Set the Output Voltage or Output Current Correctly

---

### **The output voltage cannot be set correctly.**

Have you tried to specify a value that is higher than the OVP trip point? You cannot set the output voltage to a value that is 95% of the OVP trip point or higher. Check the OVP trip point.

Have you tried to set a voltage value that is lower than the voltage value that is specified by UVL? You cannot set the output voltage to a value that is lower than the voltage that is specified by UVL. Check the voltage that is specified by UVL.

### **The output current cannot be set correctly.**

Have you tried to specify a value that is higher than the OCP trip point? You cannot set the output current to a value that is 95% of the OCP trip point or higher. Check the OCP trip point.

## Output is Unstable

---

### **When the output is on, turning the VOLTAGE knob or CURRENT knob results in unstable output.**

Is the operation mode switching from CV to CC or CC to CV? Change the setting (output voltage or output current) that is limiting the output to a value greater than the present setting. If the setting is at maximum, you must use a power supply that has a larger output voltage or current.

**The output voltage or output current fluctuates.**

Are you using master-slave parallel operation? Compared to independent operation, the performance degrades slightly during master-slave parallel operation.

Are the remote sensing cables and the sensing connectors connected? When you are not using remote sensing, connect the sensing connectors in local sensing mode.

Are both the CV and CC LEDs turned on? If the output is oscillating when you are using remote sensing, insert a capacitor across the load.

The circuit may be malfunctioning. Immediately stop using the RMX programmable power supply, and have it repaired.

Do the sensing cables or load cables have poor contact, or are the cables broken? Turn the POWER switch off, and check the wiring.

Does the load current have peaks, or is it pulse shaped? The peak values may be exceeding the set constant current. Increase the set constant current or increase the current capacity.

**The output voltage is offset from the voltage that the RMX programmable power supply was generating when it was turned on.**

Has 30 minutes passed since the power was turned on? Warm up the RMX programmable power supply for at least 30 minutes.

**Is the bleeder circuit set to oFF?**

Is the bleeder circuit set to oFF? If the bleeder circuit is set to oFF, the voltage that was present when the output was on will remain. Set the bleeder circuit to on.

## Output Ripple is Large

---

**The ripple sometimes becomes large.**

Is the input voltage outside the range? Apply a voltage that is within the input voltage range.

**The ripple increased when the RMX programmable power supply was installed in a different location.**

Is something nearby generating a strong magnetic or electrical field? Take measures such as moving the RMX programmable power supply away from the field sources or twisting the cables connected to the RMX programmable power supply.

**The output ripple is large during external control.**

Is there a large amount of external voltage noise? Take measures against noise.

**The ripple increased when the load cable was changed.**

Are the remote sensing cables connected? When you are not using remote sensing, disconnect the remote sensing cables.

# ALARM LED Lights When the OUTPUT Switch is On

---

## **The ALARM LED lights when the OUTPUT switch is turned on.**

Are the remote sensing cables and the sensing connectors connected? When you are not using remote sensing, connect the sensing connectors in local sensing mode.

Are the polarities of the remote sensing cables connected in reverse? The polarities of the remote sensing cables may be connected in reverse, or the ends of the cables may be shorted. Check the load cables.

Are you using remote sensing with long load cables? Set up the environment so that the voltage drop in each load cable is within the compensation voltage range. Refer to Appendix A, [Specifications](#), for details about how much voltage remote sense can compensate for.

Are you using external control with a loose control cable? Connect the cable correctly. Is the external voltage excessive during external control? Apply the correct voltage.

Is the internal temperature too high? The overheat protection function has been activated. Check the operating environment. The inlet may be clogged, or the fan may be broken.

## **The ALARM LED lights when the load is changed.**

Is a large external voltage—such as that of a battery load—being applied? Is the actual output voltage higher than the set voltage that is displayed on the panel? Is a special load connected?

The overvoltage protection function or the overcurrent protection function may have been activated. Check them. The RMX programmable power supply may be overloaded. Check the load.

# Unable to Perform Panel Operations

---

## **Unable to perform panel operations.**

Is the LOCK LED lit? Release the panel operation lock.

Is the REMOTE LED lit? Or is the RMX programmable power supply being controlled via the RS232C, USB, or LAN interface? To control the RMX programmable power supply from the panel, press the LOCAL switch to switch to local mode.

## **The RMX programmable power supply does not switch to local mode even when the LOCAL switch is pressed.**

Was a local lockout (llo) command sent through the communication interface? Send the “SYST:LOC” communication command to clear the local lockout (llo) status.



## Unable to Perform Remote Control

---

### **Remote control through the communication interface cannot be performed.**

Have you enabled the LAN interface in the CONFIG settings? Set the LAN interface parameter (CF20) to "on". Also make sure that the Command language parameter (CF21) is set to "SCPi".

### **When the LAN interface is in use, the IP address cannot be obtained from the DHCP server.**

Is the LAN LED lit in orange or red? If it is lit in orange, the RMX programmable power supply is waiting for a response from the DHCP server. If it turns red afterward, the RMX programmable power supply may have timed out. Consult your network administrator.

## Unable to Control Functions Properly

---

### **The bleeder on/off function does not work.**

Are you using master-slave parallel operation or series operation? When using master-slave parallel operation or series operation, set the bleeder on/off settings (CF11) of all connected units to the same value.

---

# NI Services

NI provides global services and support as part of our commitment to your success. Take advantage of product services in addition to training and certification programs that meet your needs during each phase of the application life cycle; from planning and development through deployment and ongoing maintenance.

To get started, register your product at [ni.com/myproducts](https://ni.com/myproducts).

As a registered NI product user, you are entitled to the following benefits:

- Access to applicable product services.
- Easier product management with an online account.
- Receive critical part notifications, software updates, and service expirations.

Log in to your MyNI user profile to get personalized access to your services.

---

## Services and Resources

- **Maintenance and Hardware Services**—NI helps you identify your systems' accuracy and reliability requirements and provides warranty, sparing, and calibration services to help you maintain accuracy and minimize downtime over the life of your system. Visit [ni.com/services](https://ni.com/services) for more information.
  - **Warranty and Repair**—All NI hardware features a one-year standard warranty that is extendable up to five years. NI offers repair services performed in a timely manner by highly trained factory technicians using only original parts at a NI service center.
  - **Calibration**—Through regular calibration, you can quantify and improve the measurement performance of an instrument. NI provides state-of-the-art calibration services. If your product supports calibration, you can obtain the calibration certificate for your product at [ni.com/calibration](https://ni.com/calibration).
- **System Integration**—If you have time constraints, limited in-house technical resources, or other project challenges, National Instruments Alliance Partner members can help. To learn more, call your local NI office or visit [ni.com/alliance](https://ni.com/alliance).

- **Training and Certification**—The NI training and certification program is the most effective way to increase application development proficiency and productivity. Visit [ni.com/training](https://ni.com/training) for more information.
  - The Skills Guide assists you in identifying the proficiency requirements of your current application and gives you options for obtaining those skills consistent with your time and budget constraints and personal learning preferences. Visit [ni.com/skills-guide](https://ni.com/skills-guide) to see these custom paths.
  - NI offers courses in several languages and formats including instructor-led classes at facilities worldwide, courses on-site at your facility, and online courses to serve your individual needs.
- **Technical Support**—Support at [ni.com/support](https://ni.com/support) includes the following resources:
  - **Self-Help Technical Resources**—Visit [ni.com/support](https://ni.com/support) for software drivers and updates, a searchable KnowledgeBase, product manuals, step-by-step troubleshooting wizards, thousands of example programs, tutorials, application notes, instrument drivers, and so on. Registered users also receive access to the NI Discussion Forums at [ni.com/forums](https://ni.com/forums). NI Applications Engineers make sure every question submitted online receives an answer.
  - **Software Support Service Membership**—The Standard Service Program (SSP) is a renewable one-year subscription included with almost every NI software product, including NI Developer Suite. This program entitles members to direct access to NI Applications Engineers through phone and email for one-to-one technical support, as well as exclusive access to online training modules at [ni.com/self-paced-training](https://ni.com/self-paced-training). NI also offers flexible extended contract options that guarantee your SSP benefits are available without interruption for as long as you need them. Visit [ni.com/ssp](https://ni.com/ssp) for more information.
- **Declaration of Conformity (DoC)**—A DoC is our claim of compliance with the Council of the European Communities using the manufacturer’s declaration of conformity. This system affords the user protection for electromagnetic compatibility (EMC) and product safety. You can obtain the DoC for your product by visiting [ni.com/certification](https://ni.com/certification).

For information about other technical support options in your area, visit [ni.com/services](https://ni.com/services), or contact your local office at [ni.com/contact](https://ni.com/contact).

You also can visit the Worldwide Offices section of [ni.com/niglobal](https://ni.com/niglobal) to access the branch office websites, which provide up-to-date contact information, support phone numbers, email addresses, and current events.

# Index

---

## A

alarm, 2-12  
    clearing, 2-13  
    occurrence, 2-12  
alarms, 2-11

## B

bleeder  
    on/off feature, 2-41

## C

calibration  
    calibration procedure  
        connection, 5-5  
    environment, 5-4  
    hardware requirements, 5-4  
    items, 5-2  
    overview, 5-1  
    system requirements, 5-4  
CC power supply, 2-7  
CE compliance specifications, A-22  
clearing alarms, 2-13  
CONFIG  
    parameters, 2-25  
    settings, 2-20  
    settings (table), 2-21  
crossover point, 2-8  
CV power supply, 2-7

## D

display  
    measured value, 2-1  
    power, 2-1  
    setting, 2-2

## E

electromagnetic compatibility, A-22  
external control, 3-1

## F

factory default settings, 2-45

fall time, 2-44  
fine adjustment, 2-3

## H

Hardware, 5-4

## J

J1 connector, 3-1  
J2 connector, 3-5

## K

key lock, 2-41

## L

local sensing, 1-19

## M

maintenance, 5-1

## O

options  
    signal cable, 1-23  
output operations, 2-3

## P

panel operations, 2-3  
parallel operation, 4-1  
power supply  
    CC, 2-7  
    CV, 2-7  
preset memory, 2-39  
protection functions, 2-11

## R

remote sensing, 1-19  
RMX-4120  
    dimensions, A-11  
    specifications, A-2  
RMX-4121  
    dimensions, A-11

## Index

- specifications, A-2
- RMX-4122
  - dimensions, A-11
  - specifications, A-2
- RMX-4123
  - dimensions, A-11
  - specifications, A-2
- RMX-4124
  - dimensions, A-21
  - specifications, A-12
- RMX-4125
  - dimensions, A-21
  - specifications, A-12
- RMX-4126
  - dimensions, A-21
  - specifications, A-12
- RMX-4127
  - dimensions, A-21
  - specifications, A-12

## S

- safety specifications, A-22
- sensing
  - cable connections, 1-18
  - local, 1-19
  - remote, 1-19
  - terminals and functions (table), 1-18
- series
  - alarm, 4-10
  - connection, 4-10
  - external monitoring, 4-8
  - operation, 4-8
  - remote sensing, 4-9
  - settings, 4-11
  - starting, 4-11
- series operation, 4-1
- specifications, A-1
  - CE compliance, A-22
  - electromagnetic compatibility, A-22
  - safety, A-22
- switching
  - from Remote Mode to Local Mode, 2-44

## T

- troubleshooting, B-1