

COMPREHENSIVE SERVICES

We offer competitive repair and calibration services, as well as easily accessible documentation and free downloadable resources.

SELL YOUR SURPLUS

We buy new, used, decommissioned, and surplus parts from every NI series. We work out the best solution to suit your individual needs.

 Sell For Cash  Get Credit  Receive a Trade-In Deal

OBSOLETE NI HARDWARE IN STOCK & READY TO SHIP

We stock **New**, **New Surplus**, **Refurbished**, and **Reconditioned** NI Hardware.



Bridging the gap between the manufacturer and your legacy test system.

 1-800-915-6216

 www.apexwaves.com

 sales@apexwaves.com

All trademarks, brands, and brand names are the property of their respective owners.

Request a Quote

 **CLICK HERE**

SCB-68A

NI PXIe-7846R

R Series Reconfigurable I/O Module (AI, AO, DIO) for PXI Express, 8 AI, 8 AO, 48 DIO, 500 kS/s AI, Kintex-7 160T FPGA

This document provides compliance, pinout, connectivity, mounting, and power information for the NI PXIe-7846R.

Hardware Overview

The following high-level block diagram represents the NI PXIe-7846R.

Figure 1. NI PXIe-7846R Block Diagram

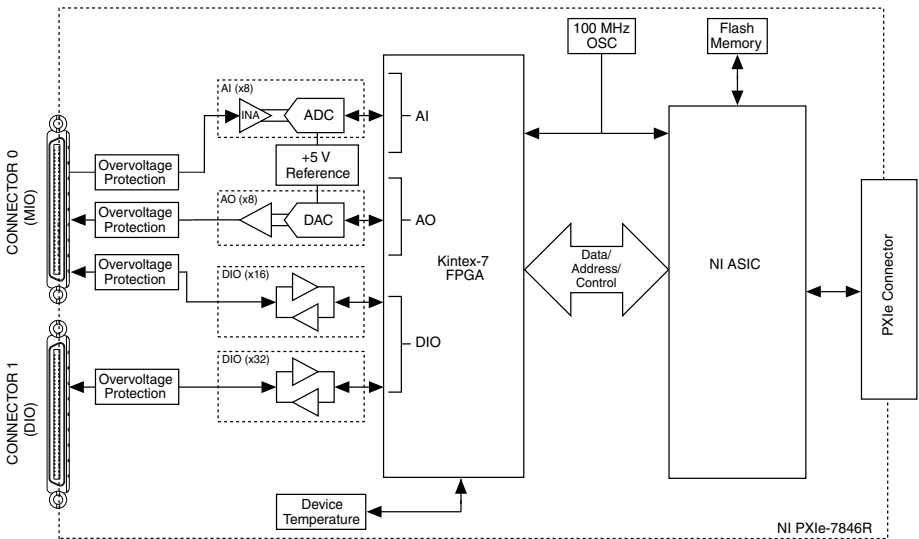

Pinout

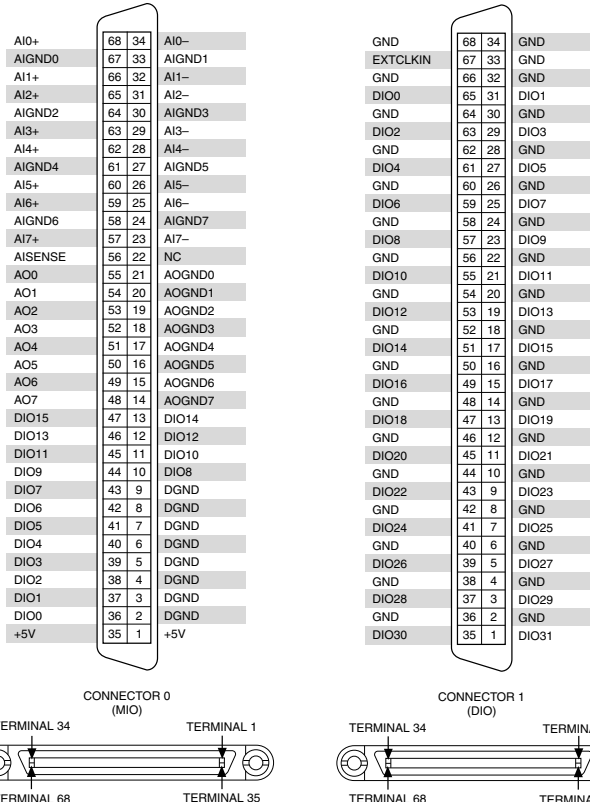

Table 1. NI PXIe-7846R Signal Descriptions

Signal	Description
AI+	Positive analog input signal connection
AI-	Negative analog input signal connection
AISENSE	Reference connection for NRSE measurements
AIGND	Ground reference for the analog input signal
AO	Analog output signal connection
AOGND	Ground reference for the analog output signal

Table 1. NI PXIe-7846R Signal Descriptions (Continued)

Signal	Description
DIO	Digital input/output signal connection
DGND	Ground reference for the digital signal
EXTCLKIN	External clock input source that can be used for source synchronous acquisitions. The provided clock source must be stable and glitch-free.
GND	Ground connection
Supply (+5 Vout)	5 V power output connection for external devices
NC	No connection

The NI PXIe-7846R is protected from overvoltage and overcurrent conditions.



Note Refer to the device specifications, available at ni.com/manuals for more information.

Connectivity Options

Use the following connection accessories and cables to access the signals on the I/O connectors.

Table 2. Connection Accessories and Cables

Connector Type	Accessory	Description	NI Part Number
DIO	NI SCB-68 HSDIO	Shielded 68-Pin Connector Block for R Series DIO and HSDIO Products	782914-01
	NI SHC68-C68-RDIO2	Shielded R Series High Speed Digital Cable (1 m)	156166-01
		Shielded R Series High Speed Digital Cable (2 m)	156166-02
MIO	NI SCB-68A	Noise Rejecting, Shielded I/O Connector Block	782536-01
	NI SHC68-68-RMIO	RMIO Shielded Cable, 68 pin D-Type to 68 pin VHDCI (1 m)	189588-01
		RMIO Shielded Cable, 68 pin D-Type to 68 pin VHDCI (2 m)	189588-02

Analog Input

The NI PXIe-7846R provides connections for eight AI channels. Each channel has an AI+ pin, AI- pin, and AIGND pin to which you can connect both single-ended or differential voltage signals. Use the AISENSE pin to connect non-referenced single-ended signals.

Connecting Single-Ended Voltage Signals

To connect referenced single-ended voltage signals to the NI PXIe-7846R, you must connect the voltage ground signal to AI GND in order to keep the common-mode voltage in the specified range.

Figure 2. Connecting Referenced Single-Ended Signals to the NI PXIe-7846R

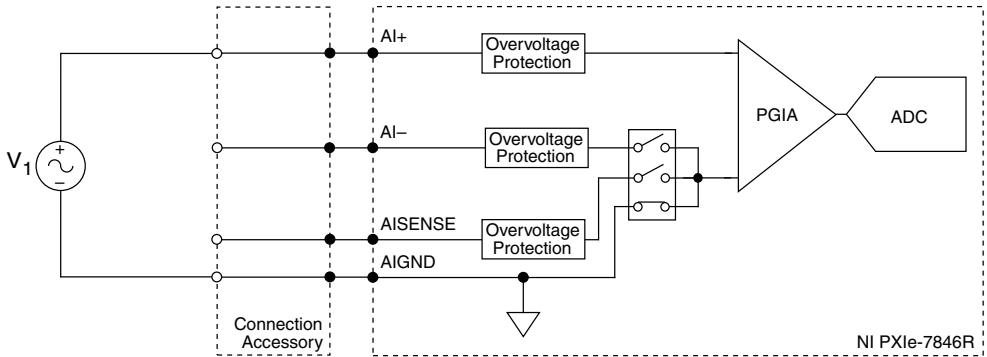

To connect non-referenced single-ended voltage signals to the NI PXIe-7846R, you must connect the voltage ground signal to AI SENSE in order to keep the common-mode voltage in the specified range.

Figure 3. Connecting Non-Referenced Single-Ended Signals to the NI PXIe-7846R

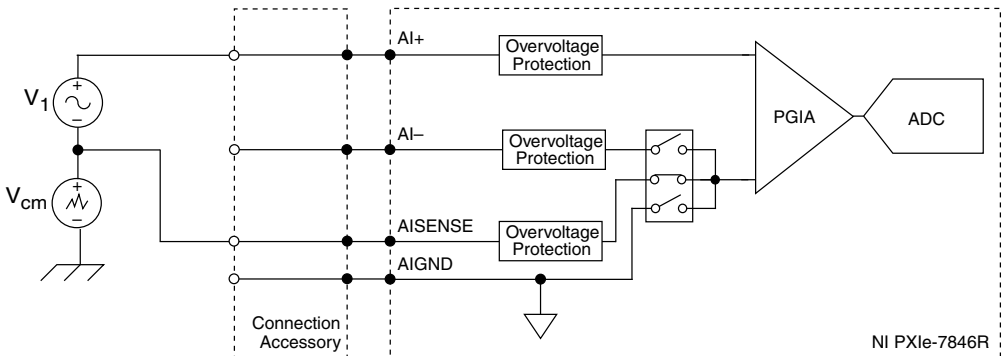

Connecting Differential Voltage Signals

You can connect grounded or floating differential signal sources to the NI PXIe-7846R. Connect the positive voltage signal to the AI+ and the negative voltage signal to AI-. To connect grounded differential signals to the NI PXIe-7846R, you must also connect the signal reference to AI GND.

Figure 4. Connecting Grounded Differential Signals to the NI PXIe-7846R

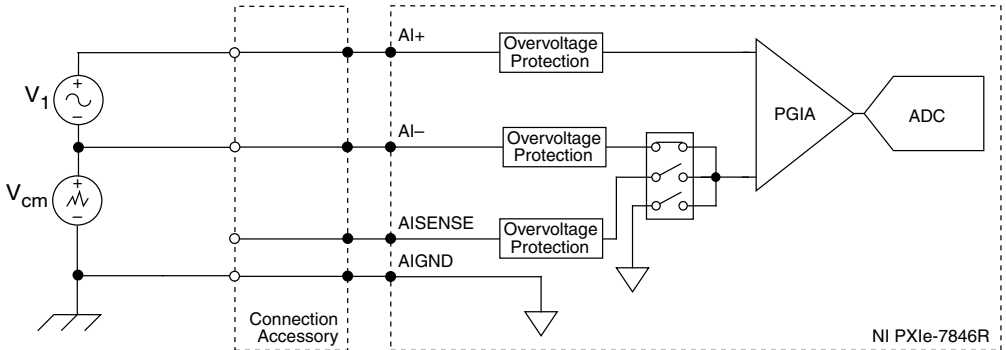

To connect floating differential signals to the NI PXIe-7846R, you must connect the negative and positive signals to AI GND through 1 M Ω resistors to keep the voltage within the common-mode voltage range. If the voltage source is outside the common-mode voltage range, the NI PXIe-7846R does not read data accurately.

Figure 5. Connecting Floating Differential Signals to the NI PXIe-7846R

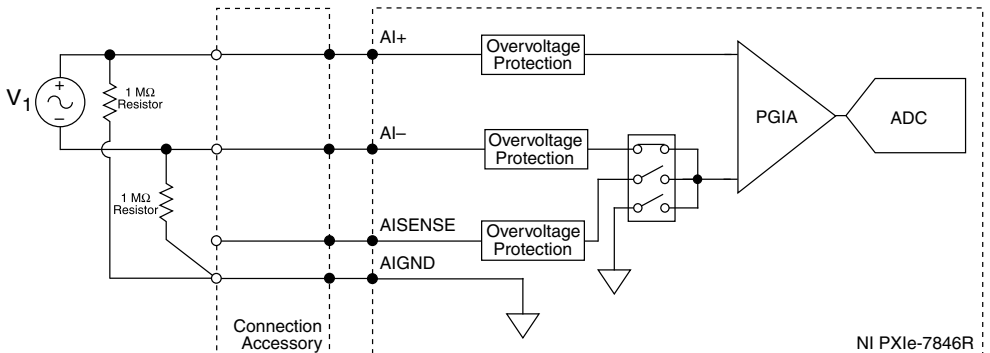

Analog Output

The NI PXIe-7846R provides connections for eight analog output channels. Each channel has an AO pin and AOGND pin to which you can connect a load.

Figure 6. Connecting a Load

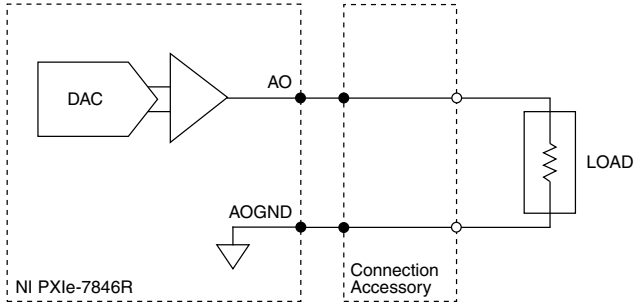

Digital I/O

The NI PXIe-7846R provides connections for 48 digital input/output (DIO) channels. Connector 0 contains 16 low-speed channels that can run up to 10 MHz signal frequencies and Connector 1 contains 32 high-speed DIO channels that can run up to 80 MHz signal frequencies. Each connector has selectable logic levels that you can configure as 1.2 V, 1.5 V, 1.8 V, 2.5 V, or 3.3 V. You can configure each channel as input or output.

Figure 7. Connecting to the DIO Channels

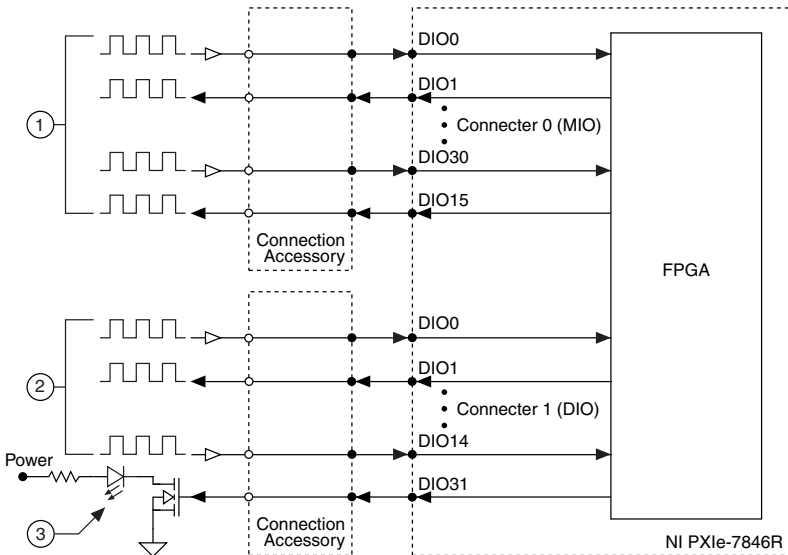

1. Low-speed signal frequencies up to 10 MHz with logic levels configured as 1.2 V, 1.5 V, 1.8 V, 2.5 V, or 3.3 V.
2. High-speed signal frequencies up to 80 MHz with logic levels configured as 1.2 V, 1.5 V, 1.8 V, 2.5 V, or 3.3 V.
3. LED

The DIO channels connect to the FPGA through buffers, which have overvoltage and undervoltage protection as well as over current protection. Refer to the device specifications on ni.com/manuals for more information about the maximum voltage and current.

When the system powers on, the DIO channels are set as input low with pull-down resistors. To set another power-on state, you can configure the NI PXIe-7846R to load a VI when the system powers on. The VI can then set the DIO lines to any power-on state.

All the high-speed DIO channels on Connector 1 are routed with a 50 Ω characteristic trace impedance. Route all external circuitry with a similar impedance to ensure best signal quality. NI recommends performing signal integrity measurements to test the affect of signal routing with the cable and connection accessory for your application.

Field Wiring Considerations

Environmental noise can seriously affect the measurement accuracy of the device if you do not take proper care when running signal wire between signal sources and the device. The following recommendations mainly apply to AI signal routing to the device, as well as signal routing in general.

Take the following precautions to minimize noise pickup and maximize measurement accuracy:

- Use differential AI connections to reject common-mode noise.
- Use individually shielded, twisted-pair wires to connect AI signals to the device. With this type of wire, the signal attached to the positive and negative inputs are twisted together and then covered with a shield. You then connect this shield only at one point to the signal source ground. This kind of connection is required for signals traveling through areas with large magnetic fields or high electromagnetic interference.
- Route signals to the device carefully. Keep cabling away from noise sources, such as video monitors and analog signals.

Use the following recommendations for all signal connections to the NI PXIe-7846R:

- Separate NI PXIe-7846R signal lines from high-current or high-voltage lines. These lines can induce currents in or voltages on the NI PXIe-7846R signal lines if they run in parallel paths at a close distance. To reduce the magnetic coupling between lines, separate them by a reasonable distance if they run in parallel or run the lines at right angles to each other.
- Do not run signal lines through conduits that also contain power lines.
- Protect signal lines from magnetic fields caused by electric motors, welding equipment, breakers, or transformers by running them through special metal conduits.

+5 V Power Source

Use the +5 V terminals on the I/O connector supply +5 V referenced to DGND to power external circuitry.



Caution Never connect the +5 V power terminals to analog or digital ground or any other voltage source on the NI PXIe-7846R or any other device. Doing so can

damage the device and the computer. National Instruments is not liable for damage resulting from such a connection.

The power rating is 4.75 to 5.1 VDC at 0.5 A.

Worldwide Support and Services

The NI website is your complete resource for technical support. At ni.com/support, you have access to everything from troubleshooting and application development self-help resources to email and phone assistance from NI Application Engineers.

Visit ni.com/services for NI Factory Installation Services, repairs, extended warranty, and other services.

Visit ni.com/register to register your NI product. Product registration facilitates technical support and ensures that you receive important information updates from NI.

A Declaration of Conformity (DoC) is our claim of compliance with the Council of the European Communities using the manufacturer's declaration of conformity. This system affords the user protection for electromagnetic compatibility (EMC) and product safety. You can obtain the DoC for your product by visiting ni.com/certification. If your product supports calibration, you can obtain the calibration certificate for your product at ni.com/calibration.

NI corporate headquarters is located at 11500 North Mopac Expressway, Austin, Texas, 78759-3504. NI also has offices located around the world. For telephone support in the United States, create your service request at ni.com/support or dial 1 866 ASK MYNI (275 6964). For telephone support outside the United States, visit the *Worldwide Offices* section of ni.com/niglobal to access the branch office websites, which provide up-to-date contact information, support phone numbers, email addresses, and current events.

Refer to the *NI Trademarks and Logo Guidelines* at ni.com/trademarks for information on NI trademarks. Other product and company names mentioned herein are trademarks or trade names of their respective companies. For patents covering NI products/technology, refer to the appropriate location: **Help»Patents** in your software, the `patents.txt` file on your media, or the *National Instruments Patent Notice* at ni.com/patents. You can find information about end-user license agreements (EULAs) and third-party legal notices in the readme file for your NI product. Refer to the *Export Compliance Information* at ni.com/legal/export-compliance for the NI global trade compliance policy and how to obtain relevant HTS codes, ECCNs, and other import/export data. NI MAKES NO EXPRESS OR IMPLIED WARRANTIES AS TO THE ACCURACY OF THE INFORMATION CONTAINED HEREIN AND SHALL NOT BE LIABLE FOR ANY ERRORS. U.S. Government Customers: The data contained in this manual was developed at private expense and is subject to the applicable limited rights and restricted data rights as set forth in FAR 52.227-14, DFAR 252.227-7014, and DFAR 252.227-7015.

© 2016 National Instruments. All rights reserved.

375944A-03 May16