

COMPREHENSIVE SERVICES

We offer competitive repair and calibration services, as well as easily accessible documentation and free downloadable resources.

SELL YOUR SURPLUS

We buy new, used, decommissioned, and surplus parts from every NI series. We work out the best solution to suit your individual needs.

 Sell For Cash  Get Credit  Receive a Trade-In Deal

OBSOLETE NI HARDWARE IN STOCK & READY TO SHIP

We stock **New**, **New Surplus**, **Refurbished**, and **Reconditioned** NI Hardware.



Bridging the gap between the manufacturer and your legacy test system.

 1-800-915-6216

 www.apexwaves.com

 sales@apexwaves.com

All trademarks, brands, and brand names are the property of their respective owners.

Request a Quote

 **CLICK HERE**

SCC-68

USER GUIDE

SCC-RTD01 Resistance Temperature Detector

The SCC-RTD01 resistance temperature detector (RTD) input module accepts up to two RTD input signals from 2-, 3-, or 4-wire RTDs. Each module consists of two RTD input channels, a 30 Hz Butterworth lowpass filter for each channel, and a 1 mA excitation current source. Each input channel includes an instrumentation amplifier with differential inputs and a fixed gain of 25.

The SCC-RTD01 filters RTD inputs and passes them through a differential amplifier with a fixed gain of 25 resulting in a maximum input voltage of 400 mVDC. The output of the amplifier passes through a three-pole, 30 Hz Butterworth lowpass filter. The SCC-RTD01 provides a 1 mA excitation current source for RTDs.

Conventions

The following conventions are used in this guide:

»

The » symbol leads you through nested menu items and dialog box options to a final action. The sequence **File»Page Setup»Options** directs you to pull down the **File** menu, select the **Page Setup** item, and select **Options** from the last dialog box.



This icon denotes a note, which alerts you to important information.



This icon denotes a caution, which advises you of precautions to take to avoid injury, data loss, or a system crash. When this symbol is marked on the product, refer to the *Read Me First: Safety and Radio-Frequency Interference* document, shipped with the product, for precautions to take.



When symbol is marked on a product, it denotes a warning advising you to take precautions to avoid electrical shock.



When symbol is marked on a product, it denotes a component that may be hot. Touching this component may result in bodily injury.

ADE	Application Development Environment
bold	Bold text denotes items that you must select in software, such as menu items and dialog box options. Bold text also denotes parameter names.
<i>italic</i>	Italic text denotes variables, emphasis, a cross-reference, or an introduction to a key concept. Italic text also denotes text that is a placeholder for a word or value that you must supply.
monospace	Text in this font denotes text or characters that you should enter from the keyboard, sections of code, programming examples, and syntax examples. This font is also used for the proper names of disk drives, paths, directories, programs, subprograms, subroutines, device names, functions, operations, variables, filenames, and extensions.
SC-2345	SC-2345 refers to both the SC-2345 connector block and the SC-2345 with configurable connectors.
SCC	SCC refers to any SCC Series signal conditioning module.

What You Need to Get Started

To set up and use the SCC-RTD01, you need the following items:

- Hardware
 - SCC-68
 - or
 - SC-2345/2350 with one of the following:
 - SCC-PWR01
 - SCC-PWR02 and the PS01 power supply
 - SCC-PWR03 (requires a 7 to 42 VDC power supply, not included)
 - One or more SCC-RTD01 modules
 - 68-pin E/M Series DAQ device
 - 68-pin cable
 - Quick Reference Label
- Software
 - The latest version of NI-DAQmx

- Documentation
 - One of the following:
 - *SC-2345/2350 User Manual*
 - *SCC-68 User Guide*
 - *SCC-RTD01 Resistance Temperature Detector User Guide*
 - *Read Me First: Safety and Radio-Frequency Interference*
 - *SCC Quick Start Guide*
- Tools
 - 1/8 in. flathead screwdriver
 - Numbers 1 and 2 Phillips screwdrivers
 - Wire insulation strippers



Note If you do not have the current version of NI-DAQmx or one of the documents, you can download them from the National Instruments Web site at ni.com or contact an NI sales representative. Software scaling of measurements is not supported on the Macintosh operating system. Refer to the [Specifications](#) section for information about software scaling.

Device Specific Information



Note For general SCC module installation and signal connection information, and information about the SC-2345 or SC-2350 carrier, refer to the *SCC Quick Start Guide*, available for download at ni.com/manuals.

Installing the Module



Caution Refer to the *Read Me First: Safety and Radio-Frequency Interference* document before removing equipment covers or connecting/disconnecting any signal wires.

You can plug the SCC-RTD01 into any AI socket on the SCC. The SCC-RTD01 can function as a single-stage module or as the first stage of a dual-stage signal conditioning configuration. The socket you choose determines which E/M Series DAQ device channels receive the SCC-RTD01 signals, as explained in the *SCC Quick Start Guide*.

For single-stage input conditioning, plug the SCC-RTD01 into any socket J(X+1), where X is 0 to 7, and connect the input signals to the module as described in the *SCC Quick Start Guide*.

If you use the SCC-RTD01 in a dual-stage configuration, the SCC-RTD01 must be the first stage. Plug the SCC-RTD01 into any socket J(X+9) and plug the second-stage SCC into socket J(X+1), where X is 0 to 7. Connect the input signals to the SCC-RTD01 as described in the *SCC Quick Start Guide*. The SC-2345 connects the output signals of the first-stage SCC to the inputs of the second-stage SCC. An example of dual-stage conditioning is an SCC-AIXX isolated analog input module followed by an SCC-LPXX lowpass filter module.



Note Refer to the *SC-2345/2350 User Manual* for more information on single-stage and dual-stage signal conditioning and configuration.

Connecting the Input Signals



Note The signal names have changed. Refer to ni.com/info and enter `rdtntg` to confirm the signal names.

The SCC-RTD01 has six pins and provides two differential AI channels for measuring the voltage across RTDs. Pins 1 and 2 form a differential channel routed to E/M Series DAQ device channel X+8, and pins 3 and 4 form a second differential channel routed to E/M Series DAQ device channel X, where X is 0 to 7 depending on the socket of the SCC-RTD01. Pins 5 and 6 carry the 1 mA constant-current excitation source.

For information on how the I/O pins on the bottom of the SCC-RTD01 correspond to signals on the E/M Series DAQ device, refer to the [I/O Connector Pin Assignments](#) section.

Signal sources can be floating or ground-referenced. The SCC-RTD01 has high-impedance bias resistors typically required for floating sources. Therefore, floating signal sources do not require external bias resistors connected to ground.



Note For floating signal sources in high-noise environments, connect the negative terminal of the signal source to the AI SENSE terminal on the SC-2345/2350 screw-terminal block to reduce common-mode noise.

You can connect one or two RTDs to the SCC-RTD01 in 2-, 3-, and 4-wire configurations. Figure 1 contains wiring diagrams for connecting one 2-, 3-, or 4-wire RTD to the SCC-RTD01.

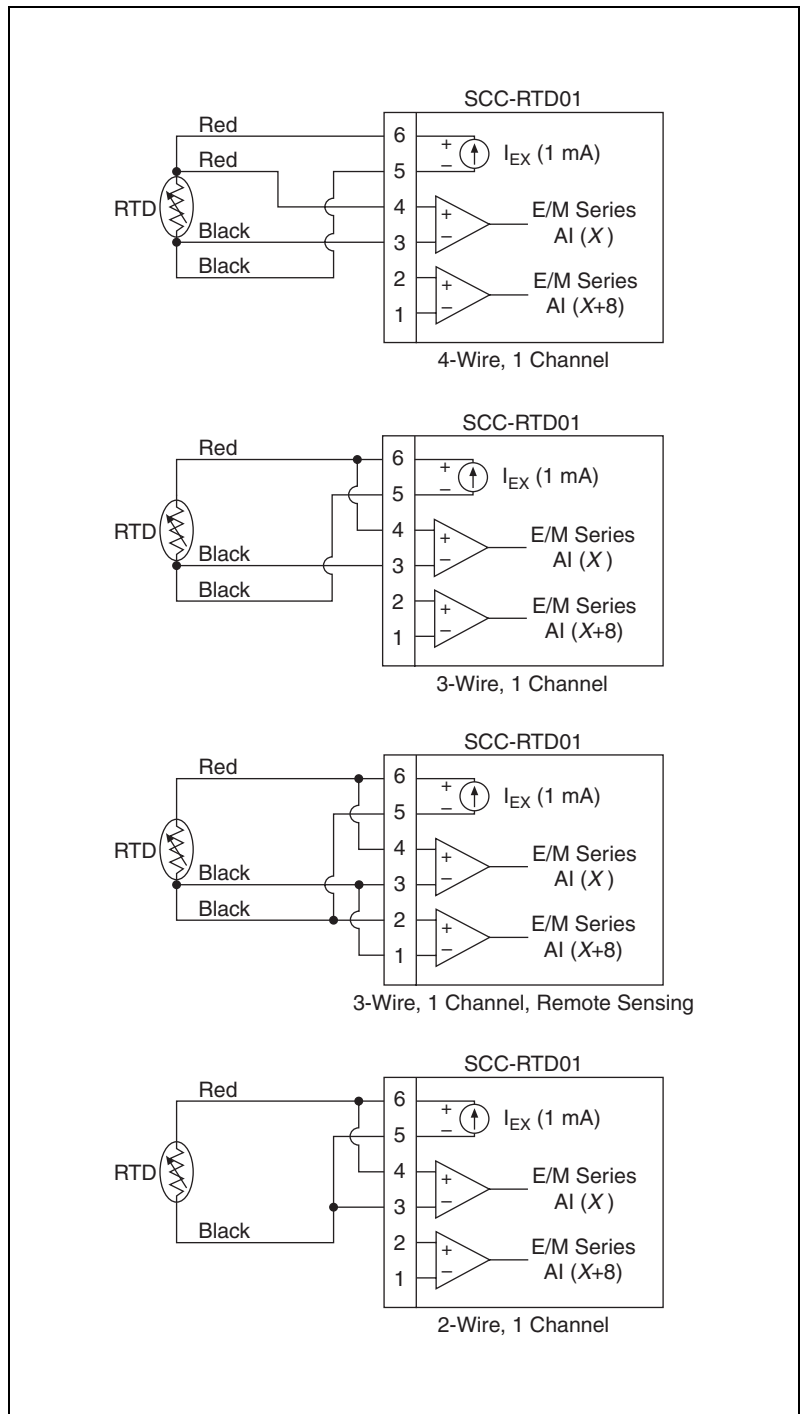

Figure 1. SCC-RTD01 Single-Channel Wiring Diagrams

Figure 2 contains wiring diagrams for connecting two 2-, 3-, or 4-wire RTDs to the SCC-RTD01.

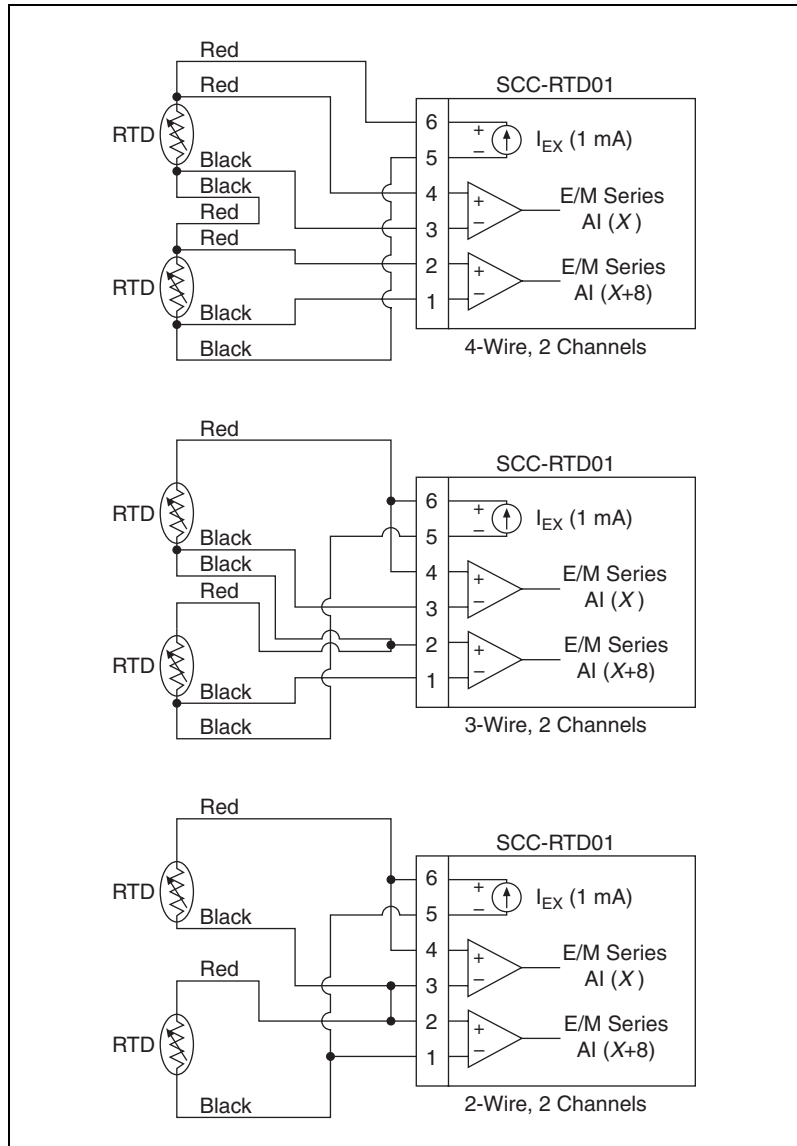

Figure 2. SCC-RTD01 Two-Channel Wiring Diagrams



Note Use 4-wire transducer connections for a more accurate measurement. Lead resistance in 2- and 3-wire connections can introduce measurement errors.

For information about configuring the SCC-RTD01 module using NI-DAQmx, refer to the *SCC Quick Start Guide*.

Using the SCC-RTD01



Note If you have an RTD that is not supported in Measurement & Automation Explorer (MAX), Read Voltage Data and scale it in your ADE.

Converting Voltage Measurements to Temperature Measurements

If you use MAX to configure the SCC-RTD01, the reading you get from the E/M Series DAQ device is properly scaled. Otherwise, you must scale the readings and convert the voltage measurement to temperature by performing the following steps to use the standard equations for platinum RTDs:

1. Measure the RTD voltage.
 - a. Read the RTD channel on the E/M Series DAQ device and call the value $V_{ESERIES}[CH(X)]$.
 - b. Calculate the RTD voltage using the following formula:

$$V_{RTD} = \frac{V_{ESERIES}}{25}$$

where

V_{RTD} is the SCC-RTD01 input voltage.

$V_{ESERIES}$ is the E/M Series DAQ device voltage.

2. Use polynomial expressions or a conversion table provided by the RTD vendor to convert the RTD voltage to temperature.



Note NI programming environments include RTD conversion utilities that implement the voltage-to-temperature conversions. Refer to the ADE documentation for more information on these utilities.

Although the RTD resistance-versus-temperature curve is relatively linear, accurately converting resistance to temperature requires curve fitting. The Callendar-Van Dusen equation is commonly used to approximate the RTD curve:

$$R_t = R_0[1 + At + Bt^2 + C(t - 100)^3]$$

where

R_t is the resistance of the RTD at temperature t .

R_0 is the resistance of the RTD at 0 °C.

A, B, and C are the Callendar-Van Dusen coefficients shown in Table 1.

t is the temperature in °C.

Table 1. Callendar-Van Dusen Coefficients for Platinum RTDs

Standard	Temperature Coefficient	A	B	C
DIN 43760	0.003850	3.9080×10^{-3}	-5.8019×10^{-7}	-4.2735×10^{-12}
American	0.003911	3.9692×10^{-3}	-5.8495×10^{-7}	-4.3235×10^{-12}
ITS-90	0.003926	3.9848×10^{-3}	-5.870×10^{-7}	-4.0000×10^{-12}

For temperatures above 0 °C, the C coefficient equals 0. Therefore, for temperatures above 0 °C, this equation reduces to a quadratic. If you pass a known current, I_{EX} , through the RTD and measure the voltage developed across the RTD, V_0 , you can use the following formula to solve for t :

$$t = \frac{2(V_0 - I_{EX}R_0)}{I_{EX}R_0[A + \sqrt{A^2 + (4B(V_0 - I_{EX}R_0)) / (I_{EX}R_0)}}]$$

where

V_0 is the measured RTD voltage.

I_{EX} is the excitation current.

Most platinum RTD curves conform to one of the following three standardized curves:

- DIN 43760 standard
- U.S. Industrial or American standard
- International Temperature Scale (ITS)–90 (for use with wire-wound RTDs)

Specifications

These ratings are typical at 25 °C unless otherwise stated.

Analog Input

Number of input channels	2 DIFF
Input range	± 400 mVDC (fixed gain of 25 on each channel)
Overvoltage protection.....	± 42 VDC powered on ± 25 VDC powered off
Input impedance	
Normal powered on	2 M Ω in parallel with 4.7 nF
Powered off	20 k Ω min
Overload.....	20 k Ω min
Filter type	3-pole Butterworth lowpass filter
-3 dB cutoff frequency	30 Hz
System noise	4.5 μ V _{rms} (referred to the input [RTI] ¹)

Transfer Characteristics

Gain	25
Gain error	$\pm 1.2\%$
Gain-error temperature coefficient.....	± 10 ppm/ $^{\circ}$ C
Offset error	± 250 μ V (RTI)
Offset-error temperature coefficient	± 1.6 μ V/ $^{\circ}$ C
Nonlinearity	10 ppm of full scale
Recommended warm-up time	5 min

Amplifier Characteristics

Common-mode rejection ratio	110 dB at 60 Hz
Output range.....	± 10 V

¹ Calculated relative to the input range of the module.

Excitation

Number of channels	1
Constant-current source	1 mA, $\pm 0.4 \mu\text{A}$ or 0.04%
Maximum voltage level without regulation loss.....	24 V
Drift	$\pm 127 \text{ ppm}/^\circ\text{C}$

Power Requirement

Analog power	135 mW max
+15 V	4.5 mA max
-15 V	4.5 mA max
Digital power	153 mW max
+5 V	30.6 mA max

Physical

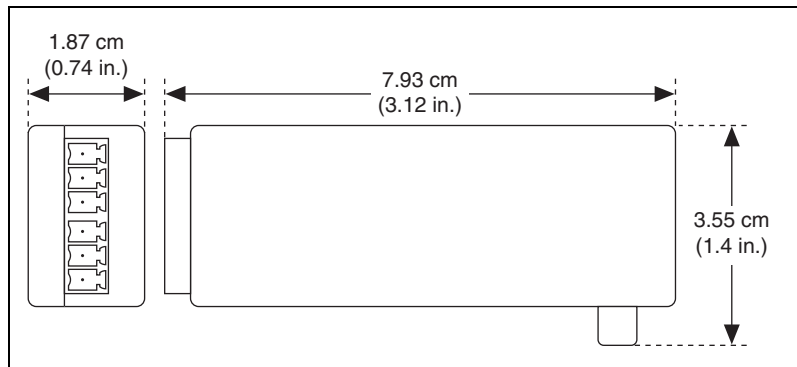

Figure 3. SCC-RTD01 Dimensions

Weight	24 g (0.8 oz)
I/O connectors.....	20-pin right-angle male connector, 6-pin screw terminal
Field-wiring diameter	28 to 16 AWG

Maximum Working Voltage

Maximum working voltage
(signal plus common mode)..... Each input should remain within
 ± 12 V of ground

Measurement Category I

Environmental

Operating temperature..... 0 to 50 °C

Storage temperature -20 to 70 °C

Humidity 5 to 90% relative humidity,
noncondensing

Maximum altitude 2,000 m

Pollution Degree (indoor use only)..... 2

Safety

This product is designed to meet the requirements of the following standards of safety for electrical equipment for measurement, control, and laboratory use:

- IEC 61010-1, EN-61010-1
- UL 61010-1, CAN/CSA-C22.2 No. 61010-1



Note For UL and other safety certifications, refer to the product label or visit ni.com/certification, search by model number or product line, and click the appropriate link in the Certification column.

Electromagnetic Compatibility

This product is designed to meet the requirements of the following standards of EMC for electrical equipment for measurement, control, and laboratory use:

- EN 61326 EMC requirements; Minimum Immunity
- EN 55011 Emissions; Group 1, Class A
- CE, C-Tick, ICES, and FCC Part 15 Emissions; Class A



Note For EMC compliance, operate this device according to product documentation.

CE Compliance

This product meets the essential requirements of applicable European Directives, as amended for CE marking, as follows:

- 73/23/EEC; Low-Voltage Directive (safety)
- 89/336/EEC; Electromagnetic Compatibility Directive (EMC)



Note Refer to the Declaration of Conformity (DoC) for this product for any additional regulatory compliance information. To obtain the DoC for this product, visit ni.com/certification, search by model number or product line, and click the appropriate link in the Certification column.

Waste Electrical and Electronic Equipment (WEEE)



EU Customers At the end of their life cycle, all products *must* be sent to a WEEE recycling center. For more information about WEEE recycling centers and National Instruments WEEE initiatives, visit ni.com/environment/weee.htm.

I/O Connector Pin Assignments

Figure 4 shows the I/O connector pins on the bottom of the module.

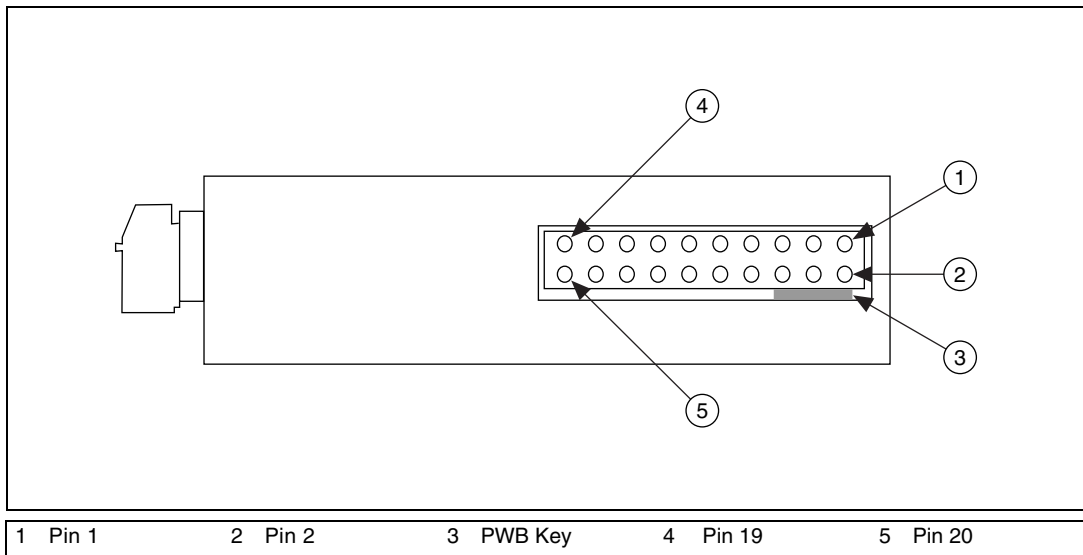

Figure 4. SCC Module Bottom View

Table 2 lists the signal connection corresponding to each pin. AI (X) and AI (X+8) are the AI signal channels of the E/M Series DAQ device. AI GND is the AI ground signal and is the reference for AI (X) and

AI (X+8). A GND is the reference for the ± 15 V supplies and REF 5 V. AI GND and A GND connect to the SC-2345/2350 at the SCC-PWR connector. GND is the reference for the +5 V supply.

Table 2. SCC-RTD01 Pin Signal Connections

Pin Number	Signal
1	DAQ Device AI (X)
2	DAQ Device AI GND
3	—
4	DAQ Device AI (X+8)
5	—
6	DAQ Device AI GND
7	—
8	DAQ Device AI GND
9	+5 V
10	GND
11	A GND
12	—
13	+15 V
14	-15 V
15	—
16	—
17	—
18	—
19	—
20	—

National Instruments, NI, ni.com, and LabVIEW are trademarks of National Instruments Corporation. Refer to the *Terms of Use* section on ni.com/legal for more information about National Instruments trademarks. Other product and company names mentioned herein are trademarks or trade names of their respective companies. For patents covering National Instruments products, refer to the appropriate location: **Help»Patents** in your software, the `patents.txt` file on your CD, or ni.com/patents.