

SCXI™-1320 HIGH-VOLTAGE TERMINAL BLOCK

This guide describes how to install and use the SCXI-1320 terminal block with your SCXI-1120, SCXI-1120D, SCXI-1121, SCXI-1125, or SCXI-1126 module.

Introduction

The SCXI-1320 terminal block is a shielded terminal block with screw terminals that connect to the SCXI-1120, SCXI-1120D, SCXI-1125, SCXI-1126, or SCXI-1121 input connector. The SCXI-1320 has a temperature sensor for precise cold-junction compensation when you make measurements with thermocouples. The SCXI-1320 can easily accommodate thermocouples, RTDs, strain gauges, thermistors, millivolt sources, and volt sources.

The terminal block has 18 screw terminals for easy connection. One pair of screw terminals connects to the SCXI module chassis ground. With the SCXI-1120/D, SCXI-1125, or SCXI-1126, the remaining eight pairs of screw terminals are for signal connection to the eight module inputs. With the SCXI-1121, four pairs of screw terminals are for the four module inputs and four pairs are for the module excitation outputs.

What You Need to Get Started

To set up and use your SCXI-1320 terminal block, you need the following items:

- SCXI-1320 terminal block
- SCXI-1320 High-Voltage Terminal Block Installation Guide*
- SCXI chassis
- One of the following modules:
 - SCXI-1120
 - SCXI-1120D

- SCXI-1121
- SCXI-1125
- SCXI-1126

- Number 1 and 2 Phillips-head screwdrivers
- 1/8 in. flathead screwdriver
- Long-nose pliers
- Wire cutter
- Wire insulation stripper

Conventions

The following conventions are used in this guide:



This icon denotes a note, which alerts you to important information.



This icon denotes a caution, which advises you of precautions to take to avoid injury, data loss, or a system crash.

italic

Italic text denotes variables, emphasis, a cross reference, or an introduction to a key concept. This font also denotes text that is a placeholder for a word or value that you must supply.

monospace

Text in this font denotes text or characters that you should enter from the keyboard, sections of code, programming examples, and syntax examples. This font is also used for the proper names of disk drives, paths, directories, programs, subprograms, subroutines, device names, functions, operations, variables, filenames and extensions, and code excerpts.

Safety Information



Caution Do *not* operate the device in an explosive atmosphere or where there may be flammable gases or fumes.

Keep away from live circuits. Do *not* remove equipment covers or shields unless you are trained to do so. If signal wires are connected to the device, hazardous voltages can exist even when the equipment is turned off. To avoid a shock hazard, do *not* perform procedures involving cover or shield removal unless you are qualified to do so and disconnect all field power prior to removing covers or shields.

Equipment described in this document must be used in an Installation Category II¹ environment per IEC 60664-1. This category requires local level supply mains-connected installation.

Do *not* operate damaged equipment. The safety protection features built into this device can become impaired if the device becomes damaged in any way. If the device is damaged, turn the device off and do *not* use it until service-trained personnel can check its safety. If necessary, return the device to National Instruments for service and repair to ensure that its safety is not compromised.

Do *not* operate this equipment in a manner that contradicts the information specified in this document. Misuse of this equipment could result in a shock hazard.

Do *not* substitute parts or modify equipment. Because of the danger of introducing additional hazards, do *not* install unauthorized parts or modify the device. Return the device to National Instruments for service and repair to ensure that its safety features are not compromised.

You *must* insulate all of your signal connections to the highest voltage with which the SCXI-1320 can come in contact.

When using the device with high common-mode voltages, you *must* insulate your signal wires for the highest input voltage. National Instruments is *not* liable for any damages or injuries resulting from inadequate signal wire insulation. Use only 26-14 AWG wire with a minimum voltage rating of 300 V and a temperature value of 60 °C for measuring up to 300 V.

When connecting or disconnecting signal lines to the SCXI terminal block screw terminals, make sure the lines are powered off. Potential differences between the lines and the SCXI ground can create a shock hazard while you connect the lines.

Connections, including power signals to ground and vice versa, that exceed any of the maximum signal ratings on the SCXI device can create a shock or fire hazard, or can damage any or all of the boards connected to the SCXI chassis, the host computer, and the SCXI device. National Instruments is *not* liable for any damages or injuries resulting from incorrect signal connections.

If hazardous voltages ($\geq 30 V_{\text{rms}}$ and $42.4 V_{\text{peak}}$ or 60 VDC) are present, you *must* connect a safety earth-ground wire to the terminal block safety-ground lug, shown in Figure 2. This complies with safety agency requirements and protects against electric shock when the terminal block is not connected to the chassis. To connect the safety earth-ground to the safety-ground lug, run an earth-ground wire from the signal source to the terminal block. National Instruments is *not* liable for any damages or injuries resulting from inadequate safety earth-ground connections.

¹ Category II refers to local-level power distribution, such as that provided by a standard wall outlet.

Do *not* loosen or re-orient the safety-ground lug hardware when connecting the safety-ground wire; to do so reduces the safety isolation between the high voltage and safety ground.

Clean the module and accessories by brushing off light dust with a soft non-metallic brush. Remove other contaminants with a stiff non-metallic brush. The unit *must* be completely dry and free from contaminants before returning it to service.

The terminal block *must* be used with a UL-listed SCXI chassis.

Temperature Sensor Output and Accuracy

The temperature sensor outputs 10 mV/°C and has an accuracy of ± 0.9 °C over the 0 to 50 °C temperature range. If your application software does not provide voltage-to-temperature conversion for the cold-junction reference (CJR) of the SCXI-1320, you can determine the CJR temperature using the following formulas:

$$T(^{\circ}\text{C}) = 100(V_{\text{TEMPOUT}})$$

$$T(^{\circ}\text{F}) = \frac{[T(^{\circ}\text{C})]9}{5} + 32$$

where V_{TEMPOUT} is the temperature sensor output voltage, and $T(^{\circ}\text{F})$ and $T(^{\circ}\text{C})$ are the temperature readings in degrees Fahrenheit and degrees Celsius, respectively.



Note Use the average of a large number of samples to obtain the most accurate reading. Electrically noisy environments require averaging for greater accuracy.

Connecting the Signals



Note Refer to the [Safety Information](#) section before removing equipment covers or connecting or disconnecting any signal wires.

When connecting your signals to the SCXI-1320, follow the labeling on the SCXI-1320 for the appropriate module, as indicated in Figure 1. For the SCXI-1120D, SCXI-1125, and SCXI-1126, follow the labeling for the SCXI-1120.

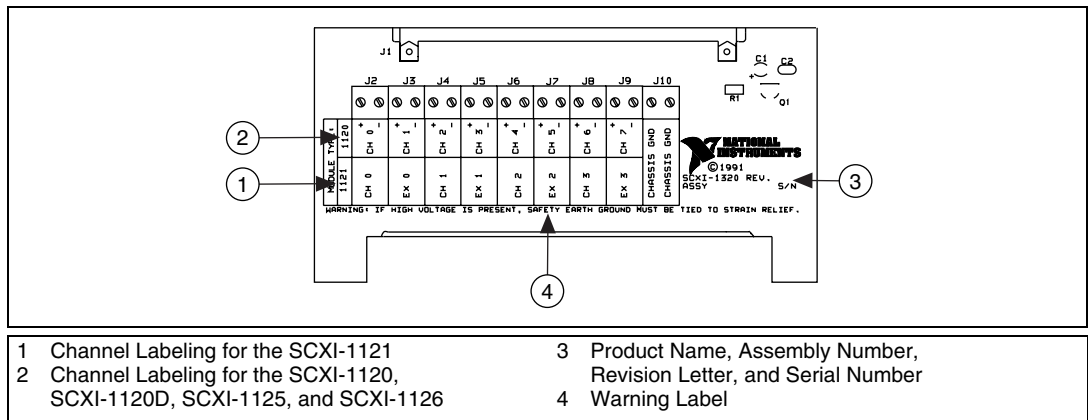

Figure 1. SCXI-1320 Signal Connections

To connect the signal to the terminal block, perform the following steps, referring to Figures 1 and 2 as necessary:

1. Unscrew the top cover screws and remove the top cover.
2. Loosen the strain-relief screws and remove the strain-relief bar.
3. Run the signal wires through the strain-relief opening. You can add insulation or padding, if necessary.
4. Prepare your signal wire by stripping the insulation no more than 7 mm.
5. Connect the wires to the screw terminals by inserting the stripped end of the wire fully into the terminal. No bare wire should extend past the screw terminal. Exposed wire increases the risk of shorting and causing a failure.
6. Tighten the screws to a torque of 5–7 in.-lb.
7. Connect safety earth ground to the safety ground lug. Refer to the [Safety Information](#) section for connection information.
8. Reinstall the strain-relief bar and tighten the strain-relief screws.
9. Reinstall the top cover and tighten the top cover screws.

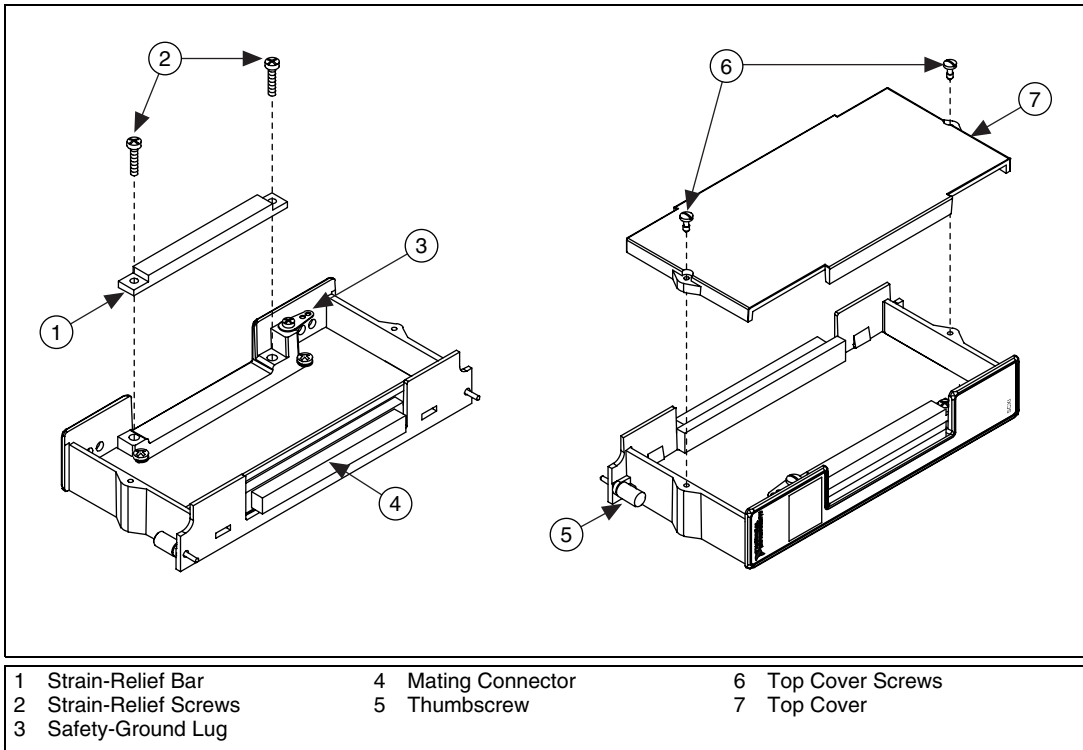

Figure 2. SCXI-1320 Parts Locator Diagram

Installing the Terminal Block

To connect the terminal block to the SCXI module front connector, perform the following steps:

1. Connect the module front connector to its mating connector on the terminal block.
2. Tighten the top and bottom thumbscrews on the back of the terminal block to hold it securely in place.



Note For accurate cold-junction compensation, place the SCXI chassis away from an extreme temperature differential.

Specifications

All specifications are typical at 25 °C unless otherwise specified.

Electrical

Compatible modules

SCXI-1120/D	8 input channels
SCXI-1121	4 input channels and 4 excitation output channels
SCXI-1125	8 input channels
SCXI-1126	8 input channels

Cold-junction temperature-sensor circuitry

Sensor type	Integrated circuit (LM35CAZ)
Output range	0 to 0.5 VDC from 0 to 50 °C (10 mV/°C)
Accuracy ¹	±1.3 °C from 0 to 50 °C
Repeatability	±0.5 °C from 35 to 50 °C
Max temperature gradient between sensor and any terminal	±0.4 °C (non-isothermal)

Coupling..... DC²

Current-receiver resistors

Resistors not included
Resistor sockets not provided

Maximum working voltage

(signal voltage plus common-mode voltage)

Channel to ground.....	Each channel must remain within 300 V _{rms} or ±300 VDC of ground
Channel to channel.....	Each channel must remain within 300 V _{rms} or ±300 VDC of the voltage applied to any other channel

¹ This includes the accuracy of the temperature sensor itself (±0.9 °C) and the temperature difference between the temperature sensor and any screw terminal (can be as large as ±0.4 °C).

² In instrumentation terminology, *DC coupling* means that both the DC and AC signals are passed.

Field-wiring connectivity	
Screw terminals for signals	16 (8 pairs)
Functional-ground terminals	2
Maximum wire gauge.....	16 AWG
Terminal spacing	0.5 cm (0.2 in.) center-to-center
Dimensions of front entrance	1.2 by 7.3 cm (0.47 by 2.87 in.)
Solder pads for additional components	
	none
Safety earth-ground lugs.....	1
Strain relief	Strain-relief bar at terminal-block entrance

Mechanical

Dimensions	17.8 by 7.94 by 3.0 cm (7.0 by 3.125 by 1.2 in.)
Weight	200 gm (7 oz.)

Environmental

Operating temperature	0 to 50 °C
Storage temperature	-20 to 70 °C
Relative humidity	10 to 90% noncondensing
Altitude (maximum)	2000 m

Safety

Designed in accordance with IEC 61010-1, UL 3111-1, and CAN/CSA C22.2 No. 1010.1 for electrical measuring and test equipment

Installation Category II

Pollution degree 2

Electromagnetic Compatibility

EMC/EMI.....	CE, C-Tick and FCC Part 15 (Class A) Compliant
Electrical emissions.....	EN 55011 Class A at 10 m, FCC Part 15A above 1 GHz
Electrical immunity.....	Evaluated to EN 61326:1998, Table 1



Note This device should only be operated with shielded cabling for full EMC and EMI compliance. See the Declaration of Conformity for this product for any additional regulatory compliance information.

Technical Support Resources

NI Web Support

National Instruments Web support is your first stop for help in solving installation, configuration, and application problems and questions. Online problem-solving and diagnostic resources include frequently asked questions, knowledge bases, product-specific troubleshooting wizards, manuals, drivers, software updates, and more. Web support is available through the Technical Support section of ni.com

Worldwide Support

National Instruments has offices located around the world to help address your support needs. You can access our branch office Web sites from the Worldwide Offices section of ni.com. Branch office Web sites provide up-to-date contact information, support phone numbers, e-mail addresses, and current events.

If you have searched the technical support resources on our Web site and still cannot find the answers you need, contact your local office or National Instruments corporate. For telephone support in the United States, dial 512 795 8248. For telephone support outside the United States, contact your local branch office:

Australia 03 9879 5166, Austria 0662 45 79 90 0, Belgium 02 757 00 20,
Brazil 011 284 5011, Canada (Calgary) 403 274 9391,
Canada (Ottawa) 613 233 5949, Canada (Québec) 514 694 8521,
China (Shanghai) 021 6555 7838, China (ShenZhen) 0755 3904939,
Denmark 45 76 26 00, Finland 09 725 725 11, France 01 48 14 24 24,
Germany 089 741 31 30, Greece 30 1 42 96 427, Hong Kong 2645 3186,
India 91805275406, Israel 03 6120092, Italy 02 413091,

Japan 03 5472 2970, Korea 02 596 7456, Mexico 5 280 7625,
Netherlands 0348 433466, New Zealand 09 914 0488,
Norway 32 27 73 00, Poland 0 22 528 94 06, Portugal 351 1 726 9011,
Singapore 2265886, Spain 91 640 0085, Sweden 08 587 895 00,
Switzerland 056 200 51 51, Taiwan 02 2528 7227,
United Kingdom 01635 523545