

## COMPREHENSIVE SERVICES

We offer competitive repair and calibration services, as well as easily accessible documentation and free downloadable resources.

## SELL YOUR SURPLUS

We buy new, used, decommissioned, and surplus parts from every NI series. We work out the best solution to suit your individual needs.

 Sell For Cash    Get Credit    Receive a Trade-In Deal

## OBSOLETE NI HARDWARE IN STOCK & READY TO SHIP

We stock **New**, **New Surplus**, **Refurbished**, and **Reconditioned** NI Hardware.



*Bridging the gap between the manufacturer and your legacy test system.*

 1-800-915-6216

 [www.apexwaves.com](http://www.apexwaves.com)

 [sales@apexwaves.com](mailto:sales@apexwaves.com)

*All trademarks, brands, and brand names are the property of their respective owners.*

**Request a Quote**

 **CLICK HERE**

**SCXI-1120D**

# TBX-1329 AC/DC COUPLING TERMINAL BLOCK

This guide describes how to install and use the TBX-1329 AC/DC coupling terminal block with the SCXI-1120, SCXI-1120D, SCXI-1121, SCXI-1125, and SCXI-1126 modules.

## Introduction

---

The TBX-1329 is a shielded, DIN-rail mountable terminal block with screw terminals to connect to the SCXI-1120, SCXI-1120D, SCXI-1121, SCXI-1125, or SCXI-1126 front connector. The TBX-1329 mounts on most European standard DIN EN mounting rails.

The terminal block has 16 screw terminals for easy connection. Two screws are provided to connect to the SCXI functional earth terminal through the SH32-32-A cable shield. With the SCXI-1120, SCXI-1120D, SCXI-1125, or SCXI-1126, the remaining eight pairs of screw terminals connect signals to the eight SCXI module input channels. With the SCXI-1121, four pairs of screw terminals connect signals to the four SCXI module input channels and four pairs connect to the SCXI module excitation channels.

## What You Need to Get Started

---

To set up and use your TBX-1329, you need the following:

- TBX-1329 AC/DC coupling terminal block
- TBX-1329 AC/DC Coupling Terminal Block Installation Guide*
- 1/8 in. flathead screwdriver (included in kit)
- SCXI chassis and documentation

- One of the following modules and its documentation:
  - SCXI-1120
  - SCXI-1120D
  - SCXI-1121
  - SCXI-1125
  - SCXI-1126
- SH32-32-A shielded cable assembly that includes the TBX cable adapter
- Long-nose pliers
- 3/16 in. wrench
- Number 1 Phillips-head screwdriver

## Conventions

---

The following conventions are used in this guide:



This icon denotes a note, which alerts you to important information.



This icon denotes a caution, which advises you of precautions to take to avoid injury, data loss, or a system crash.

*italic*

Italic text denotes variables, emphasis, a cross reference, or an introduction to a key concept. This font also denotes text that is a placeholder for a word or value that you must supply.

monospace

Text in this font denotes text or characters that you should enter from the keyboard, sections of code, programming examples, and syntax examples. This font is also used for the proper names of disk drives, paths, directories, programs, subprograms, subroutines, device names, functions, operations, variables, filenames and extensions, and code excerpts.

## Safety Information

---



**Caution** Do *not* operate the device in an explosive atmosphere or where there may be flammable gases or fumes.

Keep away from live circuits. Do *not* remove equipment covers or shields unless you are trained to do so. If signal wires are connected to the device, hazardous voltages can exist even when the equipment is turned off. To avoid a shock hazard, do *not* perform procedures involving cover or shield removal unless you are qualified to do so and disconnect all field

power prior to removing covers or shields.

Equipment described in this document must be used in an Installation Category II<sup>1</sup> environment per IEC 60664-1. This category requires local level supply mains-connected installation.

Do *not* operate damaged equipment. The safety protection features built into this device can become impaired if the device becomes damaged in any way. If the device is damaged, turn the device off and do *not* use it until service-trained personnel can check its safety. If necessary, return the device to National Instruments for service and repair to ensure that its safety is not compromised.

Do *not* operate this equipment in a manner that contradicts the information specified in this document. Misuse of this equipment could result in a shock hazard.

Do *not* substitute parts or modify equipment. Because of the danger of introducing additional hazards, do *not* install unauthorized parts or modify the device. Return the device to National Instruments for service and repair to ensure that its safety features are not compromised.

You *must* insulate all of your signal connections to the highest voltage with which the SCXI-1329 can come in contact.

When using the device with high common-mode voltages, you *must* insulate your signal wires for the highest input voltage. National Instruments is *not* liable for any damages or injuries resulting from inadequate signal wire insulation. Use only 26-14 AWG wire with a minimum voltage rating of 300 V and a temperature value of 60 °C for measuring up to 300 V.

When connecting or disconnecting signal lines to the SCXI terminal block screw terminals, make sure the lines are powered off. Potential differences between the lines and the SCXI ground can create a shock hazard while you connect the lines.

Connections, including power signals to ground and vice versa, that exceed any of the maximum signal ratings on the SCXI device can create a shock or fire hazard, or can damage any or all of the boards connected to the SCXI chassis, the host computer, and the SCXI device. National Instruments is *not* liable for any damages or injuries resulting from incorrect signal connections.

If hazardous voltages ( $\geq 30 V_{\text{rms}}$  and  $42.4 V_{\text{peak}}$  or 60 VDC) are present, you *must* connect a safety earth-ground wire to the terminal block safety-ground lug, shown in Figure 2. This complies with safety agency requirements and protects against electric shock when the terminal block is not connected to the chassis. To connect the safety earth-ground to the safety-ground lug, run an earth-ground wire from the signal source to the terminal block.

---

<sup>1</sup> Category II refers to local-level power distribution, such as that provided by a standard wall outlet.

National Instruments is *not* liable for any damages or injuries resulting from inadequate safety earth-ground connections.

Do *not* loosen or re-orient the safety-ground lug hardware when connecting the safety-ground wire; to do so reduces the safety isolation between the high voltage and safety ground.

Clean the module and accessories by brushing off light dust with a soft non-metallic brush. Remove other contaminants with a stiff non-metallic brush. The unit *must* be completely dry and free from contaminants before returning it to service.

The terminal block *must* be used with a UL-listed SCXI chassis.

## Strain-Gauge Voltage Drops When Using the SCXI-1121

---

When you use the SCXI-1121 with the TBX-1329 to measure strain, a small amount of voltage drop develops across the excitation wires in the SH32-32-A cable. This voltage drop is due to the wire resistance and the current flow in these leads when a strain gauge is connected at the TBX-1329 across the excitation outputs provided on the SCXI-1121.

To reduce errors in your output voltage, first you need to calculate the voltage drop across the SH32-32-A cable. This voltage drop, which results in an error in your measurement, depends on the cable length and on the strain gauge value and configuration. The SH32-32-A cable has a resistance of 0.21  $\Omega$ /m.

To determine the amount of error introduced by the cable, do the following:

1. Calculate the total resistance ( $R_{TL}$ ) of the cable based on the cable length.
2. Refer to your strain-gauge data sheet for the bridge resistance of the strain gauge ( $R_{SG}$ ) connected at the TBX-1329.
3. Use the following formula to determine the total voltage drop ( $V_{drop}$ ) in the SH32-32-A cable excitation leads:

$$V_{drop} = [R_{TL}/(R_{TL} + R_{SG})] \times V_{ex}$$

where  $V_{ex}$  = excitation voltage.

For example, if you have a 1 m SH32-32-A cable, 120  $\Omega$  full-bridge strain gauge, and  $V_{ex} = 3.333$  V, your calculations from Steps 1 through 3 would be:

1.  $R_{TL} = 2 \times 0.21 \text{ } \Omega/\text{m} \times 1 \text{ m} = 0.42 \text{ } \Omega$ ; you multiply the cable length by two to take into consideration both the  $V_{ex+}$  and  $V_{ex-}$  lead resistances.
2.  $R_{SG} = 120 \text{ } \Omega$  is the total equivalent bridge resistance as seen from the  $V_{ex\pm}$  terminals of the TBX-1329.

3.  $V_{drop} = 11.6 \text{ mV} \Leftrightarrow 0.3\%$  of 3.333 V excitation.

You then need to calculate the voltage drop across the field signal wires you are connecting to the TBX-1329. Perform similar calculations for your field wires as you did for your cable. Resistance can vary depending on your cable and field wires. Add this error amount to the voltage drop across the SH32-32-A cable to get a total voltage drop.

You can compensate for this error along with any additional cable lead resistance introduced by the strain-gauge connection wires. One simple way of compensating is to calculate the lead resistance as shown in Steps 1 through 3, then input it along with your other strain-gauge parameters into the conversion formula in your National Instruments data acquisition software packages. In order to minimize resistive compensation, locate the load closer to your SCXI module by using shorter cable lengths, or use heavy-gauge wire to connect to the TBX-1329.

## Measuring Current

---

To measure current with the TBX-1329, you can place a current loop receiver resistor in the sockets on the TBX-1329. Table 1 shows the TBX-1329 socket assignment per channel.



**Caution** Use only National Instruments SCXI process current resistor kits for current measurements.

**Table 1.** Socket Assignments per Channel

Channel Number	Resistor Designator
0	R0
1	R1
2	R2
3	R3
4	R4
5	R5
6	R6
7	R7

# Configuring AC/DC Coupling

Each channel of the TBX-1329 has two switches you can use to switch from AC to DC; thus, you can configure each channel individually. The factory-default setting for the switches is the DC position so that the terminal block passes all signals, DC and AC, to the SCXI module. In the AC position, the switches switch in a capacitor and, depending on which module you use, a referencing resistor. This blocks the DC components of the input signal and provides a true AC signal to the SCXI module. Each switch is uniquely marked to make switch identification easier. Each switch that switches the capacitor into the circuit is labeled with SCX. Each switch that switches the resistor into the circuit is labeled with SRX. The X symbol represents the channel number; for example, SC2 is the capacitor switch for channel 2 and SR2 is the resistor switch for channel 2. Table 2 shows the TBX-1329 terminal block switch settings.

**Table 2.** TBX-1329 Terminal Block Switch Settings

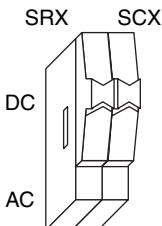
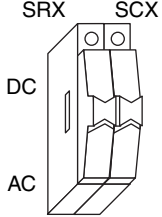
Switch Settings for Each Channel	Description	Switch Configuration	
		SCXI-1120, SCXI-1121, SCXI-1125, and SCXI-1126	SCXI-1120D
	DC coupling selected; removes capacitor and resistor from the circuit. Signals go straight through.	Switch both <i>SCX</i> and <i>SRX</i> switches for DC coupling.	Switch both <i>SCX</i> and <i>SRX</i> switches for DC coupling.
	AC coupling selected; <i>SCX</i> connects the capacitor to the circuit. <i>SRX</i> connects the resistor to the circuit.	Switch both <i>SCX</i> and <i>SRX</i> switches for AC coupling.	Switch <b>ONLY</b> <i>SCX</i> switch for AC coupling. <i>SRX</i> must be in the DC position.

# Connecting the Signals



**Note** Refer to *Safety Information* before removing equipment covers or connecting or disconnecting any signal wires.

When connecting your signals to the TBX-1329, follow the labeling on the TBX-1329 for the appropriate module, as indicated in Figure 1. When using the TBX-1329 with the SCXI-1125 or SCXI-1126, follow the SCXI-1120/1120D labeling.

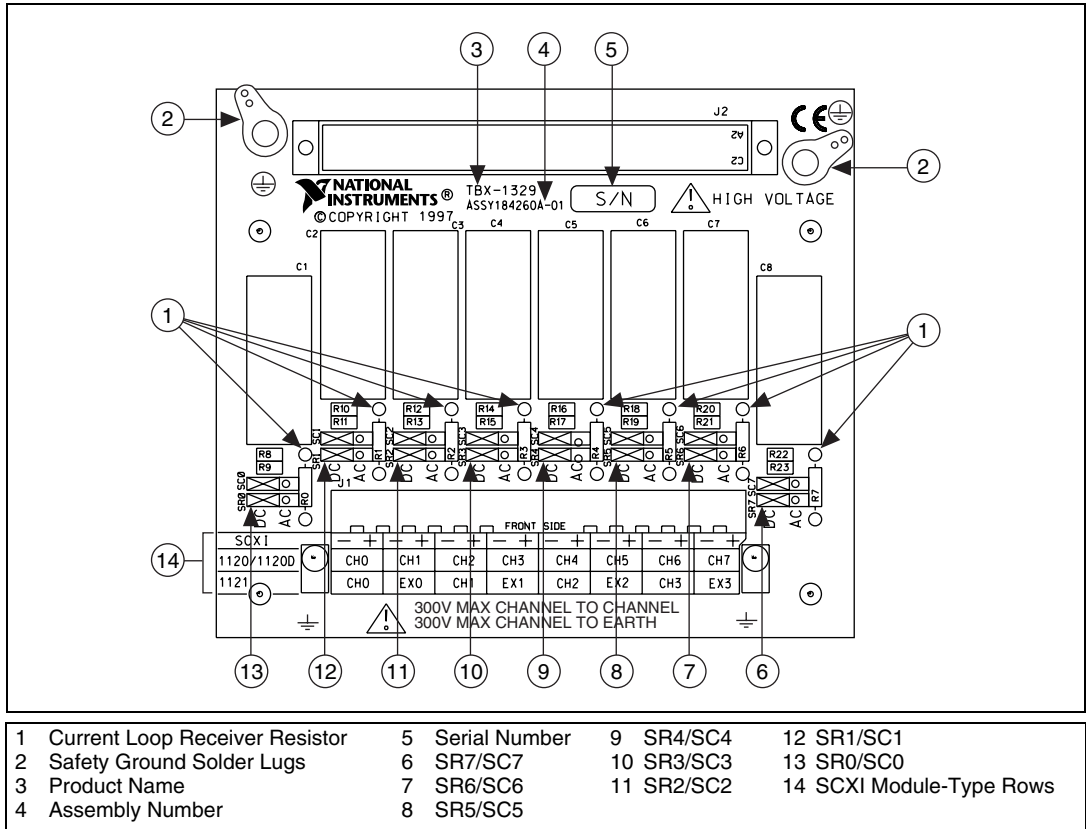

**Figure 1.** TBX-1329 Parts Locator Diagram

To connect the signal to the terminal block, perform the following steps while referring to Figure 2:

1. Remove the TBX-1329 terminal block cover by unscrewing the four captive cover screws in the cover corners. These screws stay attached to the cover without falling out.



2. Prepare your signal wire by stripping the insulation no more than 7 mm.
3. Connect the signal wires to the screw terminals by inserting the stripped end of the wire fully into the terminals.
4. Tighten the terminals to a torque of 5-7 in.-lb (56-79 Newton cm).
5. Relieve strain on your signal wires by tie-wrapping them to the mounting rails of your rack.
6. Replace the TBX-1329 terminal block cover and tighten the captive cover screws.

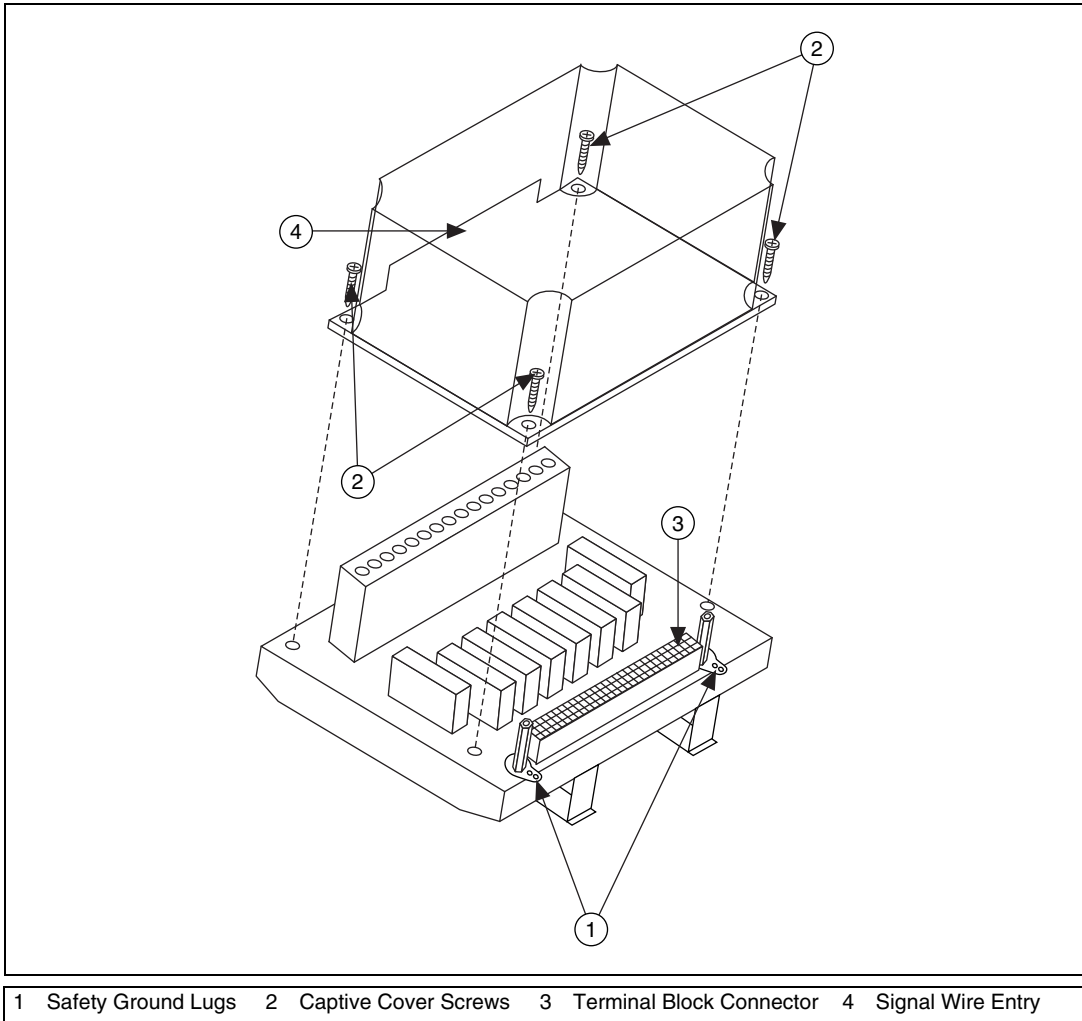

**Figure 2.** TBX-1329 Parts Locator Diagram

Refer to your SCXI module user manual for examples of how to connect to field signals and loads. The functional earth terminals are connected to the SCXI chassis through the cable shield. This is not shown in your SCXI module user manual. Allow your signal wires to exit through the TBX-1329 cover opening.

The signal connection is now complete.

## Installing the Cable and Terminal Block

---

Perform the following steps to mount the SH32-32-A cable assembly and connect the TBX-1329 to your SCXI module. Refer to Figures 3 through 5 as needed.

1. Turn off your SCXI chassis.
2. Turn off the computer that contains your data acquisition (DAQ) device or disconnect the device from your SCXI chassis.
3. Connect the TBX cable adapter to the appropriate SCXI module and secure it by tightening both thumb screws.
4. Verify that the four backshell mounting ears on the cable assembly are in the position shown in Figure 3 and Figure 4. If not, remove the backshell mounting ears and install them in the position shown.

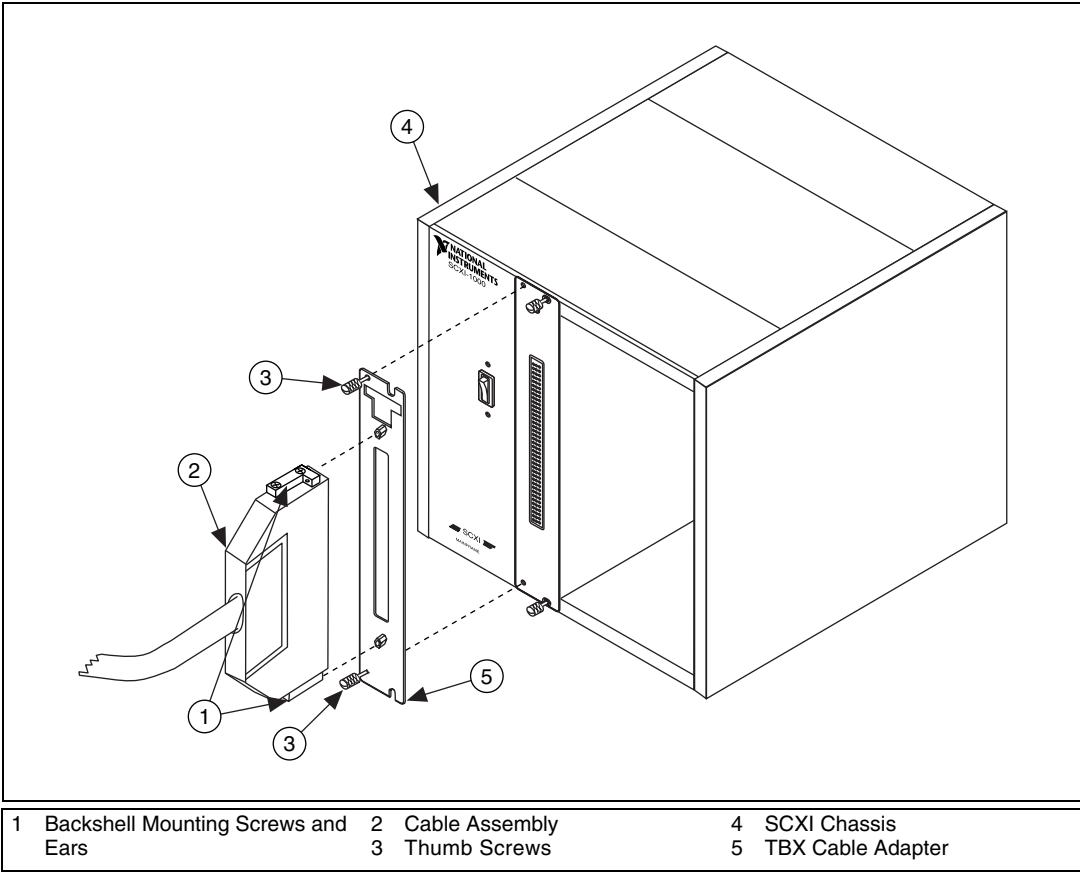

**Figure 3.** Connecting the SH32-32-A Cable to the SCXI Module

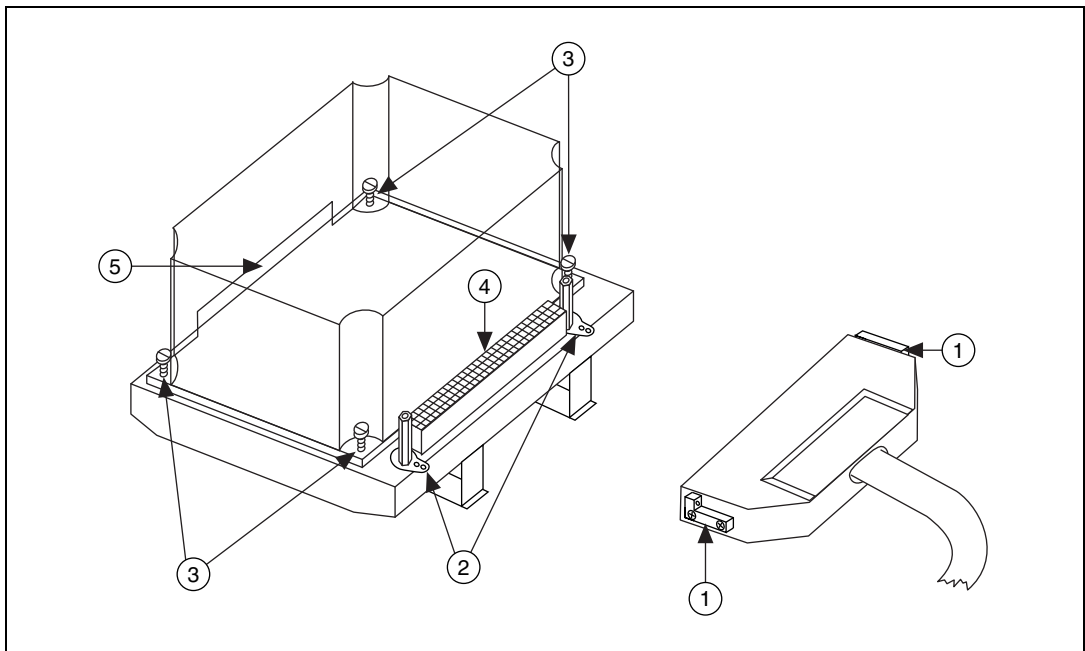

- |                                      |                            |                     |
|--------------------------------------|----------------------------|---------------------|
| 1 Backshell Mounting Screws and Ears | 3 Captive Cover Screws     | 5 Signal Wire Entry |
| 2 Safety Ground Lugs                 | 4 Terminal Block Connector |                     |

**Note:** The SH32-32-A cable is not shown in the exact position for proper connection to the terminal block connector. See Figure 5 for the completed connection.

**Figure 4.** Connecting the SH32-32-A Cable to the TBX-1329 Terminal Block

5. Connect one end of the cable assembly to your SCXI module front connector and secure the SH32-32-A cable by tightening both backshell mounting screws.
6. Connect the other end of the cable assembly to your TBX-1329 terminal block connector and secure the SH32-32-A cable by tightening both backshell mounting screws.
7. Reconnect the DAQ device to your SCXI chassis.

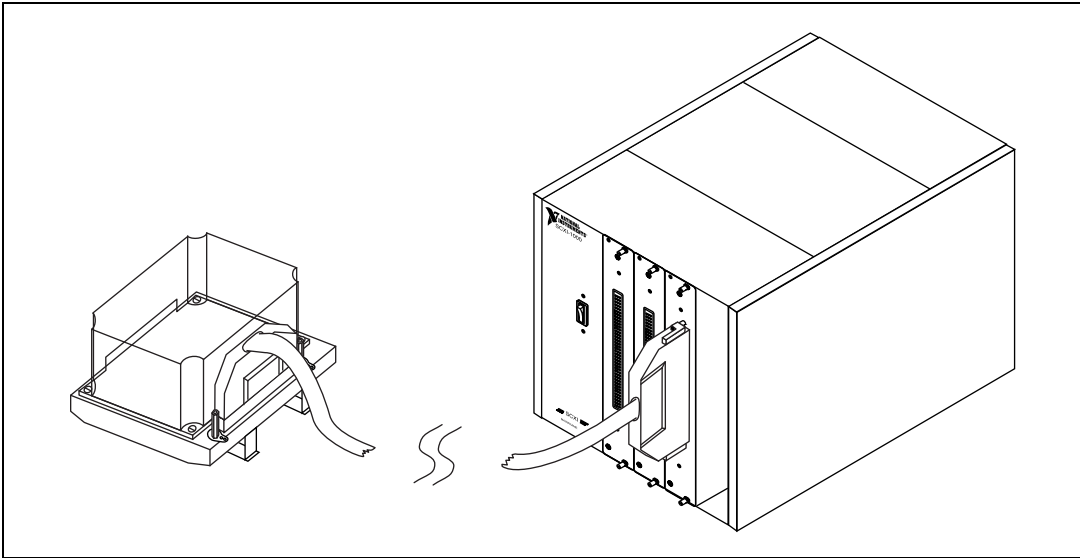

**Figure 5.** The Completed Installation

## Rack Mounting

When you have completed the installation, you are ready to mount the TBX assembly in your rack. If you are using the National Instruments TBX Rack-Mount Assembly, refer to the *TBX Rack-Mount Installation Guide* for instructions. If you are not using this rack-mount assembly, perform the following steps to mount the TBX assembly directly onto your DIN rail:

1. Snap the TBX terminal block onto the DIN rail with a firm push.
2. Install the SCXI chassis using the appropriate chassis rack-mount kit.



**Note** To remove the TBX terminal block from the DIN rail, place a flathead screwdriver into the slot above the terminal block base and pry it from the rail.

# Specifications

---

All specifications are typical at 25 °C unless otherwise specified.

## Electrical

### Compatible modules

SCXI-1120/D .....	8 input channels
SCXI-1121 .....	4 input channels and 4 excitation output channels <sup>1</sup>
SCXI-1125 .....	8 input channels
SCXI-1126 .....	8 input channels

### Coupling

DC or AC (selectable on a per-channel basis using slide switches)<sup>2</sup>

#### AC coupling circuitry

Corner frequency (–3 dB) .....	0.072 Hz
DC-blocking capacity .....	±250 VDC
Input impedance (minimum)	
Between CH+ or CH– terminals .....	2 MΩ
Between CH+ or CH– terminal and ground .....	1 MΩ

### Current-receiver resistors

Resistors included .....	none
Resistor sockets .....	8 pairs
Maximum current .....	±20 mA

### Maximum working voltage (signal + common – mode)

Channel to ground .....	Each channel must remain within 300 V <sub>rms</sub> or ±300 VDC of ground
Channel to channel .....	Each channel must remain within 300 V <sub>rms</sub> or ±300 VDC of the voltage applied to any other channel

---

<sup>1</sup> You must configure the excitation output channels for DC coupling.

<sup>2</sup> In instrumentation terminology, *DC coupling* means that both DC and AC signals are passed. *AC coupling* means that DC signals are blocked and AC signals are passed.

## Field-wiring connectors

Screw terminals (for input signals) .....	16 (8 pairs)
Terminal spacing .....	0.5 cm (0.2 in.) center-to-center
Dimensions of front entrance .....	1.2 by 7.3 cm (0.47 by 2.87 in.)
Maximum wire gauge.....	16 AWG
Strain relief .....	none
Safety earth ground.....	2 lugs

## Mechanical

Dimensions .....	12.7 by 7.62 by 11.16 cm (5 by 3 by 4.4 in.)
Weight .....	100 gm (3.5 oz.)
Compatible DIN rails.....	DIN EN 50 022 DIN EN 50 035

## Environmental

Operating temperature .....	0 to 50 °C
Storage temperature .....	-20 to 70 °C
Relative humidity .....	10 to 90% noncondensing
Altitude (maximum) .....	2000 m

## Safety

Designed in accordance with IEC 61010-1, UL 3111-1, and CAN/CSA C22.2 No. 1010.1 for electrical measuring and test equipment

Installation Category II

Pollution degree 2

# Electromagnetic Compatibility

EMC/EMI.....	CE, C-Tick and FCC Part 15 (Class A) Compliant
Electrical emissions.....	EN 55011 Class A at 10 m, FCC Part 15A above 1 GHz
Electrical immunity.....	Evaluated to EN 61326:1998, Table 1



**Note** This device should only be operated with shielded cabling for full EMC and EMI compliance. See the Declaration of Conformity for this product for any additional regulatory compliance information.

## Technical Support Resources

---

### NI Web Support

National Instruments Web support is your first stop for help in solving installation, configuration, and application problems and questions. Online problem-solving and diagnostic resources include frequently asked questions, knowledge bases, product-specific troubleshooting wizards, manuals, drivers, software updates, and more. Web support is available through the Technical Support section of [ni.com](http://ni.com)

### Worldwide Support

National Instruments has offices located around the world to help address your support needs. You can access our branch office Web sites from the Worldwide Offices section of [ni.com](http://ni.com). Branch office Web sites provide up-to-date contact information, support phone numbers, e-mail addresses, and current events.

If you have searched the technical support resources on our Web site and still cannot find the answers you need, contact your local office or National Instruments corporate. For telephone support in the United States, dial 512 795 8248. For telephone support outside the United States, contact your local branch office:

Australia 03 9879 5166, Austria 0662 45 79 90 0, Belgium 02 757 00 20,  
Brazil 011 284 5011, Canada (Calgary) 403 274 9391,  
Canada (Ottawa) 613 233 5949, Canada (Québec) 514 694 8521,  
China (Shanghai) 021 6555 7838, China (ShenZhen) 0755 3904939,  
Denmark 45 76 26 00, Finland 09 725 725 11, France 01 48 14 24 24,  
Germany 089 741 31 30, Greece 30 1 42 96 427, Hong Kong 2645 3186,  
India 91805275406, Israel 03 6120092, Italy 02 413091,



Japan 03 5472 2970, Korea 02 596 7456, Mexico 5 280 7625,  
Netherlands 0348 433466, New Zealand 09 914 0488,  
Norway 32 27 73 00, Poland 0 22 528 94 06, Portugal 351 1 726 9011,  
Singapore 2265886, Spain 91 640 0085, Sweden 08 587 895 00,  
Switzerland 056 200 51 51, Taiwan 02 2528 7227,  
United Kingdom 01635 523545