

## COMPREHENSIVE SERVICES

We offer competitive repair and calibration services, as well as easily accessible documentation and free downloadable resources.

## SELL YOUR SURPLUS

We buy new, used, decommissioned, and surplus parts from every NI series. We work out the best solution to suit your individual needs.

 Sell For Cash    Get Credit    Receive a Trade-In Deal

## OBSOLETE NI HARDWARE IN STOCK & READY TO SHIP

We stock **New, New Surplus, Refurbished, and Reconditioned** NI Hardware.



*Bridging the gap between the manufacturer and your legacy test system.*

 1-800-915-6216

 [www.apexwaves.com](http://www.apexwaves.com)

 [sales@apexwaves.com](mailto:sales@apexwaves.com)

*All trademarks, brands, and brand names are the property of their respective owners.*

**Request a Quote**

 **CLICK HERE**

**SCXI-1175**

# NI SCXI™-1175 Specifications

## 196 × 1 Relay Multiplexer

このドキュメントには、日本語ページも含まれています。

This document lists specifications for the NI SCXI-1175 196 × 1 multiplexer relay module. All specifications are subject to change without notice. Visit [ni.com/manuals](http://ni.com/manuals) for the most current specifications.

Topologies .....	1-wire 196 × 1 multiplexer
	2-wire 95 × 1 multiplexer
	2-wire 98 × 1 multiplexer

Refer to the *NI Switches Help* for detailed topology and pinout information.

### Input Characteristics



**Caution** All input characteristics are DC,  $AC_{rms}$ , or a combination unless otherwise specified.

Maximum switching voltage

Channel-to-channel .....	100 V
Channel-to-ground.....	100 V, CAT I



**Caution** This module is rated for Measurement Category I and is intended to carry signal voltages no greater than 100 V. This module can withstand up to 500 V impulse voltage. Do not use this module for connection to signals or for measurements within Categories II, III, or IV. Do not connect to MAINS supply circuits (for example, wall outlets) of 115 or 230 VAC. Refer to the *Read Me First: Safety and Electromagnetic Compatibility* document for more information about measurement categories.



**Caution** When hazardous voltages ( $>42.4 V_{pk}/60 VDC$ ) are present on any relay terminal, safety low-voltage ( $\leq 42.4 V_{pk}/60 VDC$ ) cannot be connected to any other relay terminal.



**Caution** Modules that can connect to a common high-voltage analog backplane derate to their lowest common voltage rating. Refer to the *NI Switches Getting Started Guide* for more information.



**Caution** The switching power is limited by the maximum switching current, the maximum voltage, and must not exceed 30 W, 37.5 VA.

Maximum switching power (per channel).....	30 W, 37.5 VA (DC to 60 Hz)
--	-----------------------------

DC isolation resistance..... $>1 G\Omega$ , typical at 25 °C (between channel and COM terminals)

Maximum total current.....1 A (switching or carry)

Minimum switching capacity.....10 mV/10  $\mu$ A



**Note** When routing signals through the SCXI High-Voltage Analog Backplane (HVAB), the maximum total current is 0.5 A.



**Note** Switching inductive loads (for example, motors and solenoids) can produce high voltage transients in excess of the module's rated voltage. Without additional protection, these transients can interfere with module operation and impact relay life. For more information about transient suppression, visit [ni.com/info](http://ni.com/info) and enter the Info Code `induct`.

DC path resistance	
Initial	
Through front panel.....	<0.5 Ω
Through HVAB.....	<0.8 Ω
End-of-life.....	≥1 Ω

DC path resistance typically remains low for the life of the relay. At the end of relay life, the path resistance rapidly rises above 1 Ω. Load ratings apply to relays used within the specification before the end of relay life.

Differential thermal EMF	
Typical <sup>1</sup> .....	3 μV
Maximum.....	<12 μV

Bandwidth (–3 dB, 50 Ω termination)	
1-wire.....	>20 MHz
2-wire.....	>8 MHz

Channel-to-channel isolation (50 Ω termination)

Each relay in the NI SCXI-1175 is shared by two channels. Refer to Table 4 for a list of channel pairings.

1-wire channels in different relays	
10 kHz.....	>90 dB
100 kHz.....	>70 dB
1 MHz.....	>50 dB
1-wire channels in the same relay	
10 kHz.....	>75 dB
100 kHz.....	>55 dB
1 MHz.....	>35 dB
2-wire channels	
10 kHz.....	>95 dB
100 kHz.....	>75 dB
1 MHz.....	>55 dB

Open channel isolation (50 Ω termination)	
10 kHz.....	≥85 dB
100 kHz.....	≥65 dB
1 MHz.....	≥48 dB

## Dynamic Characteristics

Relay operate time	
Typical.....	1 ms
Maximum.....	3.4 ms



**Note** Certain applications may require additional time for proper settling. For information about

including additional settling time, refer to the *NI Switches Help*.

Maximum scan rate.....	120 channels/s
------------------------	----------------

Expected relay life

Mechanical.....	5 × 10 <sup>7</sup> cycles
Electrical	
10 VDC,	
100 mADC resistive.....	1 × 10 <sup>6</sup> cycles
10 VDC, 1 ADC resistive.....	5 × 10 <sup>5</sup> cycles
30 VDC, 1 ADC resistive.....	1 × 10 <sup>6</sup> cycles
60 VDC, 1 ADC resistive.....	1 × 10 <sup>5</sup> cycles



**Note** The relays used in the NI SCXI-1175 are field replaceable. Refer to the *NI Switches Help* for information about replacing a failed relay.

## Trigger Characteristics

Input trigger

Sources.....	SCXI trigger lines 0–7, Rear connector
Minimum pulse width.....	150 ns

Output trigger

Destinations.....	SCXI trigger lines 0–7, Rear connector
Pulse width.....	Programmable (1 μs to 62 μs)

## Physical Characteristics

Relay type.....	Electromechanical, latching
Relay contact material.....	Silver, gold covered
I/O connector.....	200 POS LFH Matrix 50, receptacle
SCXI power requirement	
+5 VDC.....	50 mA
+18.5 VDC to +25 VDC.....	170 mA
–18.5 VDC to –25 VDC.....	170 mA
Dimensions (L × W × H).....	19.8 × 3.0 × 17.3 cm (7.8 × 1.2 × 6.7 in.)
Weight.....	755 g (1 lb 11 oz)

<sup>1</sup> To ensure the typical thermal EMF, power down all relays and avoid pulsing high currents near the channels you are measuring. For more information about powering down latching relays, refer to the Power Down Latching Relays After Debounce property in NI-SWITCH or the Power Down Latching Relays After Settling property in NI-DAQmx.

## Environment

Operating temperature ..... 0 °C to 50 °C  
 Storage temperature ..... -20 °C to 70 °C  
 Relative humidity ..... 5% to 85%,  
 noncondensing  
 Pollution Degree ..... 2  
 Maximum altitude ..... 2,000 m  
 Indoor use only.

## Accessories

Visit [ni.com](http://ni.com) for more information about the following accessories.

**Table 1.** NI Accessories for the NI SCXI-1175

Accessory	Part Number
LFH200 connector to bare wire switch cable, 2 m	779038-01
LFH200 to 50-pin D-SUB switch cable (CH-CH twisted), 1m	779038-03
NI TBX-50, 50-pin DSUB screw terminal block	779305-01
Relay replacement kit for G6KU-2F-Y relays	780386-01



**Note** When using either the SH200LFH-4xDB50F-S or SH200LFH-BARE WIRE cable with the NI SCXI-1175 in the 2-wire 98 × 1 topology, CH95, CH96, and CH97 will have lower RF performance than the other 95 channels because they are not in twisted pairs in the cable. To avoid using these channels, NI-SWITCH has support for a 2-wire 95 × 1 topology that does not include CH95, CH96, and CH97.



**Caution** You *must* install mating connectors according to local safety codes and standards and according to the specifications provided by the connector manufacturer. You are responsible for verifying safety compliance of third-party connectors and their usage according to the relevant standard(s), including UL and CSA in North America and IEC and VDE in Europe.

**Table 2.** Third Party Accessories for the NI SCXI-1175

Accessory	Manufacturer	Part Number
Terminal sticks (four required per module)	Molex	71715-4002
Plug connector subassembly	Molex	71719-3000
Backshell only	Jevons	JDC200B-832
Mass interconnect cable assembly, 20 in.	Virginia Panel	540105010105
Mass interconnect cable assembly, 36 in.	Virginia Panel	540105010205
Mating ITA module* (one required per module)	Virginia Panel	510108131
Mating ITA PC* (198 required per module)	Virginia Panel	720101101
* Additional cover or enclosure required. See the previous safety caution.		

**Table 3.** Third-Party Accessories for the SH200LFH-4xDB50F-S Cable

Accessory	Manufacturer	Part Number
VARIOFACE module, with screw connection and 50 position D-Subminiature pin strip	Phoenix Contact	FLK-D50 SUB/S
VARIOFACE module, with screw connection and 50 position D-Subminiature pin strip	Phoenix Contact	FLKM-D50 SUB/S
VARIOFACE module, with screw connection and 50 position D-Subminiature pin strip	Phoenix Contact	FLKMS-D50 SUB/S
VARIOFACE module, with screw connection and 50 position D-Subminiature pin strip, with LED indicators	Phoenix Contact	FLKM-D50 SUB/S/LA

**Table 4.** NI SCXI-1175 Channel Pairs

Channel Pair	Channel Pair	Channel Pair
CH0, CH95	CH33, CH128	CH66, CH161
CH1, CH96	CH34, CH129	CH67, CH162
CH2, CH97	CH35, CH130	CH68, CH163
CH3, CH98	CH36, CH131	CH69, CH164
CH4, CH99	CH37, CH132	CH70, CH165
CH5, CH100	CH38, CH133	CH71, CH166
CH6, CH101	CH39, CH134	CH72, CH167
CH7, CH102	CH40, CH135	CH73, CH168
CH8, CH103	CH41, CH136	CH74, CH169
CH9, CH104	CH42, CH137	CH75, CH170
CH10, CH105	CH43, CH138	CH76, CH171
CH11, CH106	CH44, CH139	CH77, CH172
CH12, CH107	CH45, CH140	CH78, CH173
CH13, CH108	CH46, CH141	CH79, CH174
CH14, CH109	CH47, CH142	CH80, CH175
CH15, CH110	CH48, CH143	CH81, CH176
CH16, CH111	CH49, CH144	CH82, CH177
CH17, CH112	CH50, CH145	CH83, CH178
CH18, CH113	CH51, CH146	CH84, CH179
CH19, CH114	CH52, CH147	CH85, CH180
CH20, CH115	CH53, CH148	CH86, CH181
CH21, CH116	CH54, CH149	CH87, CH182
CH22, CH117	CH55, CH150	CH88, CH183
CH23, CH118	CH56, CH151	CH89, CH184
CH24, CH119	CH57, CH152	CH90, CH185
CH25, CH120	CH58, CH153	CH91, CH186
CH26, CH121	CH59, CH154	CH92, CH187
CH27, CH122	CH60, CH155	CH93, CH188
CH28, CH123	CH61, CH156	CH94, CH189
CH29, CH124	CH62, CH157	CH190, CH193
CH30, CH125	CH63, CH158	CH191, CH194
CH31, CH126	CH64, CH159	CH192, CH195
CH32, CH127	CH65, CH160	—

Figure 1 shows the NI SCXI-1175 power-on state.

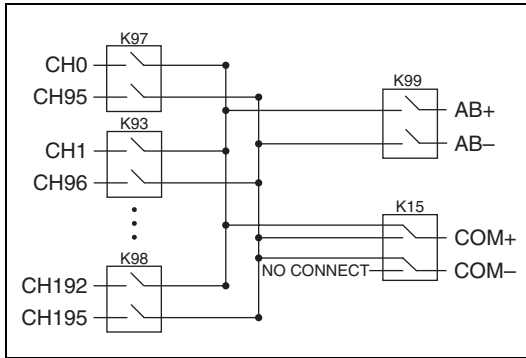

Figure 1. NI SCXI-1175 Power-On State



**Note** For EMC compliance, operate this device with shielded cables.

## CE Compliance

This product meets the essential requirements of applicable European Directives as follows:

- 2006/95/EC; Low-Voltage Directive (safety)
- 2004/108/EC; Electromagnetic Compatibility Directive (EMC)

## Online Product Certification

Refer to the product Declaration of Conformity (DoC) for additional regulatory compliance information. To obtain product certifications and the DoC for this product, visit [ni.com/certification](http://ni.com/certification), search by model number or product line, and click the appropriate link in the Certification column.

## Compliance and Certifications

### Safety

This product meets the requirements of the following standards of safety for electrical equipment for measurement, control, and laboratory use:

- IEC 61010-1, EN 61010-1
- UL 61010-1, CSA 61010-1



**Note** For UL and other safety certifications, refer to the product label or the *Online Product Certification* section.

### Electromagnetic Compatibility

This product meets the requirements of the following EMC standards for electrical equipment for measurement, control, and laboratory use:

- EN 61326 (IEC 61326): Class A emissions; Basic immunity
- EN 55011 (CISPR 11): Group 1, Class A emissions
- AS/NZS CISPR 11: Group 1, Class A emissions
- FCC 47 CFR Part 15B: Class A emissions
- ICES-001: Class A emissions



**Note** For the standards applied to assess the EMC of this product, refer to the *Online Product Certification* section.

## Environmental Management

National Instruments is committed to designing and manufacturing products in an environmentally responsible manner. NI recognizes that eliminating certain hazardous substances from our products is beneficial not only to the environment but also to NI customers.

For additional environmental information, refer to the *NI and the Environment* Web page at [ni.com/environment](http://ni.com/environment). This page contains the environmental regulations and directives with which NI complies, as well as other environmental information not included in this document.

## Waste Electrical and Electronic Equipment (WEEE)



**EU Customers** At the end of their life cycle, all products *must* be sent to a WEEE recycling center. For more information about WEEE recycling centers and National Instruments WEEE initiatives, visit [ni.com/environment/weee.htm](http://ni.com/environment/weee.htm).

## 电子信息产品污染控制管理办法（中国 RoHS）



**中国客户** National Instruments 符合中国电子信息产品中限制使用某些有害物质指令 (RoHS)。关于 National Instruments 中国 RoHS 合规性信息, 请登录 [ni.com/environment/rohs\\_china](http://ni.com/environment/rohs_china)。(For information about China RoHS compliance, go to [ni.com/environment/rohs\\_china](http://ni.com/environment/rohs_china).)

National Instruments, NI, ni.com, and LabVIEW are trademarks of National Instruments Corporation. Refer to the *Terms of Use* section on [ni.com/legal](http://ni.com/legal) for more information about National Instruments trademarks. Other product and company names mentioned herein are trademarks or trade names of their respective companies. For patents covering National Instruments products/technology, refer to the appropriate location: **Help»Patents** in your software, the `patents.txt` file on your media, or the *National Instruments Patent Notice* at [ni.com/patents](http://ni.com/patents).