

COMPREHENSIVE SERVICES

We offer competitive repair and calibration services, as well as easily accessible documentation and free downloadable resources.

SELL YOUR SURPLUS

We buy new, used, decommissioned, and surplus parts from every NI series. We work out the best solution to suit your individual needs.

 Sell For Cash  Get Credit  Receive a Trade-In Deal

OBSOLETE NI HARDWARE IN STOCK & READY TO SHIP

We stock **New**, **New Surplus**, **Refurbished**, and **Reconditioned** NI Hardware.



Bridging the gap between the manufacturer and your legacy test system.

 1-800-915-6216

 www.apexwaves.com

 sales@apexwaves.com

All trademarks, brands, and brand names are the property of their respective owners.

Request a Quote

 **CLICK HERE**

SCXI-1192

Specifications for the NI SCXI™-1192

18 GHz 8-SPDT 50 Ω Relay Module

This document lists specifications for the NI SCXI-1192 relay module. All specifications are subject to change without notice. Visit ni.com/manuals for the most current specifications.

Configuration 8-channel SPDT

RF Performance Characteristics

Characteristic impedance (Z_0)..... 50 Ω nominal

Insertion loss

≤4 GHz..... <0.2 dB
≤8 GHz..... <0.3 dB
≤12.4 GHz..... <0.4 dB
≤18 GHz..... <0.5 dB

VSWR

≤1 GHz..... <1.10
≤4 GHz..... <1.15
≤8 GHz..... <1.25
≤12.4 GHz..... <1.35
≤18 GHz..... <1.50

Open channel isolation

≤1 GHz..... >85 dB
≤4 GHz..... >80 dB
≤8 GHz..... >70 dB
≤12.4 GHz..... >65 dB
≤18 GHz..... >60 dB

National Instruments™, NI™, ni.com™, and SCXI™ are trademarks of National Instruments Corporation. Product and company names mentioned herein are trademarks or trade names of their respective companies. For patents covering National Instruments products, refer to the appropriate location: **Help»Patents** in your software, the `patents.txt` file on your CD, or ni.com/patents.

April 2003
323482A-01

Input Characteristics

All input characteristics are DC, AC_{rms}, or a combination unless otherwise specified.

Maximum switching voltage30 V
(channel-to-channel and channel-to-ground)

Maximum carry current2 A
(per channel)



Note National Instruments recommends against switching active RF signals. As a relay actuates, the channel is momentarily unterminated. Some RF sources can be damaged by reflections if their outputs are not properly terminated. Consult your RF source documentation for more information.

Maximum RF carry power120 W up to 3 GHz
(per channel) 80 W up to 8 GHz
60 W up to 12.4 GHz
50 W up to 18 GHz

The input power for each channel should not exceed the preceding specifications. When carrying active signals on multiple channels, refer to Table 1 for adjusted maximum input power.

Table 1. Maximum Carry Power Per Channel (No Switching)

Active Channels	1 GHz to 3 GHz	3 GHz to 8 GHz	8 GHz to 12.4 GHz	12.4 GHz to 18 GHz
1	120 W	80 W	60 W	50 W
2	60 W	40 W	30 W	25 W
4	30 W	20 W	15 W	12.5 W
8	15 W	10 W	7.5 W	6.25 W

DC path resistance

Initial.....<0.1 Ω

End of life>1 Ω

Path resistance is a combination of relay contact resistance and trace resistance. Contact resistance typically remains low for the life of a relay. At the end of relay life, the contact resistance rises rapidly above 1.0 Ω.

Dynamic Characteristics

Maximum cycle speed	2 cycles/s
Relay operate time (at 20 °C).....	15 ms
Expected relay life	
Mechanical	5,000,000 cycles
Electrical	5,000,000 cycles
(5 W, 3 GHz, 50 Ω, VSWR maximum 1.2)	

Physical Characteristics

Relay type	Electromechanical, latching
I/O connectors	24 SMA jacks
Contact material	Gold plate
Dimensions (W × H × D).....	3.0 cm × 17.3 cm × 19.6 cm (1.2 in. × 6.7 in. × 7.6 in.)
Weight.....	1090 g (2 lb 7 oz)

Environment

Operating temperature.....	0 °C to 50 °C
Storage temperature	-20 °C to 70 °C
Relative humidity	5% to 85% noncondensing
Pollution Degree	2

Compliance and Certifications

Safety

This product is designed to meet the requirements of the following standards of safety for electrical equipment for measurement, control, and laboratory use:

- IEC 61010-1, EN 61010-1
- UL 3111-1, UL 61010B-1
- CAN/CSA C22.2 No. 1010.1



Note For UL and other safety certifications refer to the product label or visit ni.com.

Electromagnetic Compatibility

Emissions	EN 55011 Class A at 10 m FCC Part 15A above 1 GHz
Immunity	EN 61326:1997 + A2:2001, Table 1
EMC/EMI	CE, C-Tick and FCC Part 15 (Class A) Compliant



Note For EMC compliance, you *must* operate this device with shielded cabling.

CE Compliance

This product meets the essential requirements of applicable European Directives, as amended for CE Marking, as follows:

Low-Voltage Directive (safety).....73/23/EEC

Electromagnetic Compatibility
Directive (EMC).....89/336/EEC



Note Refer to the Declaration of Conformity (DoC) for this product for any additional regulatory compliance information. To obtain the DoC for this product, click **Declarations of Conformity Information** at ni.com/hardref.nsf/.

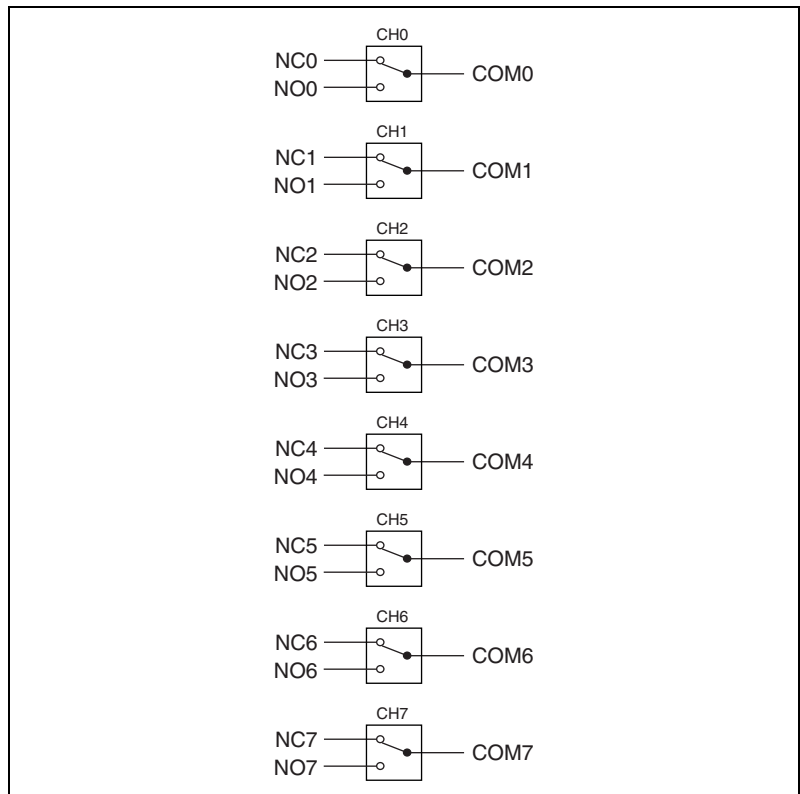

Figure 1. NI SCXI-1192 8-SPDT