

COMPREHENSIVE SERVICES

We offer competitive repair and calibration services, as well as easily accessible documentation and free downloadable resources.

SELL YOUR SURPLUS

We buy new, used, decommissioned, and surplus parts from every NI series. We work out the best solution to suit your individual needs.

 Sell For Cash  Get Credit  Receive a Trade-In Deal

OBSOLETE NI HARDWARE IN STOCK & READY TO SHIP

We stock **New**, **New Surplus**, **Refurbished**, and **Reconditioned** NI Hardware.



Bridging the gap between the manufacturer and your legacy test system.

 1-800-915-6216

 www.apexwaves.com

 sales@apexwaves.com

All trademarks, brands, and brand names are the property of their respective owners.

Request a Quote

 **CLICK HERE**

SCXI-1304

SCXI™-1304 AC/DC COUPLING TERMINAL BLOCK INSTALLATION GUIDE

This guide describes how to install and use the National Instruments SCXI-1304 AC/DC coupling terminal block with the SCXI-1140, SCXI-1141/1142/1143, SCXI-1120/D, SCXI-1125, and SCXI-1126 modules.

The SCXI-1304 AC/DC is a shielded terminal block with screw terminals that you can connect to the SCXI-1140, SCXI-1141/1142/1143, SCXI-1120/D, SCXI-1125, or SCXI-1126 input connector. You can configure each SCXI-1304 channel to provide AC or DC coupling of a signal to the SCXI module, and each channel can ground reference a floating signal with a bias resistor.

The terminal block has 22 screw terminals for easy signal connection. You can use eight pairs of screw terminals for signal connections to the eight module inputs and one pair to connect to the module analog ground. The remaining four screw terminals provide access to the digital ground and digital signals of the module. These signals are HOLDTRIG for the SCXI-1140, and OUTCLK and EXTCLK for the SCXI-1141/1142/1143.

Conventions

The following conventions are used in this manual:

»

The » symbol leads you through nested menu items and dialog box options to a final action. The sequence **File»Page Setup»Options** directs you to pull down the **File** menu, select the **Page Setup** item, and select **Options** from the last dialog box.



This icon denotes a note, which alerts you to important information.



This icon denotes a caution, which advises you of precautions to take to avoid injury, data loss, or a system crash. When this symbol is marked on the product, refer to the *Read Me First: Safety and Radio-Frequency Interference* document, shipped with the product, for precautions to take.

National Instruments™, NI™, ni.com™, and SCXI™ are trademarks of National Instruments Corporation. Product and company names mentioned herein are trademarks or trade names of their respective companies. For patents covering National Instruments products, refer to the appropriate location: **Help»Patents** in your software, the `patents.txt` file on your CD, or ni.com/patents.

January 2003
321922B-01

bold	Bold text denotes items that you must select or click in the software, such as menu items and dialog box options. Bold text also denotes parameter names.
<i>italic</i>	Italic text denotes variables, emphasis, a cross reference, or an introduction to a key concept. This font also denotes text that is a placeholder for a word or value that you must supply.
monospace	Text in this font denotes text or characters that you should enter from the keyboard, sections of code, programming examples, and syntax examples. This font is also used for the proper names of disk drives, paths, directories, programs, subprograms, subroutines, device names, functions, operations, variables, filenames and extensions, and code excerpts.

What You Need to Get Started

To set up and use the SCXI-1304 terminal block, you need the following items:

- SCXI-1304 AC/DC coupling terminal block
- SCXI-1304 AC/DC Coupling Terminal Block Installation Guide*
- Read Me First: Safety and Radio-Frequency Interference*
- SCXI chassis and documentation
- One of the following modules and its associated documentation:
 - SCXI-1140
 - SCXI-1141/1142/1143
 - SCXI-1120/D
 - SCXI-1125
 - SCXI-1126
- Numbers 1 and 2 Phillips screwdrivers
- 1/8 in. flathead screwdriver
- Long-nose pliers
- Wire cutter
- Wire insulation stripper

Configuring Floating and Ground-Referenced Signals



Note You can use the SCXI-1304 terminal block with SCXI-1120/D, SCXI-1125, and SCXI-1126 modules. However, when using these modules, the channel isolation specification is invalid if the bias resistors are in the engaged position. You must leave the resistor switches in the open or G grounded position to keep the isolation valid.

Signal sources are either floating sources or ground-referenced sources.



- **Floating signal source**—does not connect in any way to the building ground system and therefore has an isolated ground-reference point that you cannot assume to be at the same potential as any other ground. Examples of this source type include transformers, insulated thermocouples, optical isolators, isolation amplifiers, and battery-powered devices.
- **Ground-referenced signal source**—connects to the building ground and thus shares a common ground with the E Series data acquisition (DAQ) device, assuming that the computer is also connected to the building power supply and there are no ground loops. Examples of ground-referenced signals are the nonisolated outputs of any devices that plug into the building power supply, such as signal/function generators and power supplies. Isolated outputs do not constitute ground-referenced sources; treat them as floating sources.

In general, you should reference an input signal to ground at only one point. Therefore, do not reference the input of a differential amplifier module to ground if the signal source is already ground referenced. If you are measuring a floating source, reference the input to ground.

You can ground reference a floating signal for each channel by using the switch settings shown in Table 1. Refer to Figure 2 for switch locations. Each channel has one switch with two positions as follows:

- **Floating signal sources**—Use position F. Setting one of these switches to position F connects a 100 k Ω resistor between the negative input screw terminal for the channel and analog ground. This resistor provides the necessary reference to ground for the channel.
- **Ground-referenced sources**—Use position G. Setting the switch to position G disconnects the resistor from the signal path.

Table 1. Floating and Ground-Referenced Signal Configuration

Switch Position	Description
	Use this setting to provide a reference to ground for floating signals.
	Use this setting for signals that are already ground referenced (factory setting).

Configuring AC/DC Coupling

You can configure each channel for either AC or DC coupling using the switch settings shown in Table 2. Refer to Figure 2 for switch locations. Each channel requires two switches that must be in the same position for the coupling circuitry to properly operate. Configure the channels as follows:

- **AC coupling**—Set both switches to the AC position. This position places single-pole highpass filters in the paths of both the positive and negative channel inputs. Each filter consists of a 1 μ F DC blocking capacitor and a 1 M Ω resistor to analog ground, giving a -3 dB cutoff frequency of 0.16 Hz. The capacitors can block up to 50 VDC.
- **DC coupling**—Set both switches to the DC position. DC coupling removes the filters from the signal paths and connects the screw terminals directly to the module inputs.

Table 2. AC/DC Coupling Configuration

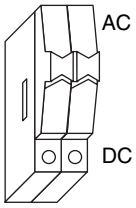
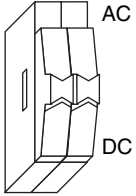
Switch Position	Description
	Use this setting to AC couple the input signal.
	Use this setting to DC couple the input signal (factory setting).

Connecting the Signals

When connecting the signals to the SCXI-1304, follow the labeling on the SCXI-1304 for the appropriate module, as indicated in Figure 2.

To connect the signal to the terminal block, complete the following steps, referring to Figures 1 and 2 as necessary:

1. Unscrew the top cover screws and remove the cover.
2. Configure each of the AC/DC coupling and ground-referencing switches, depending on the signal you are measuring. The top set of switches (S1, S2, and S3) corresponds to input channel 0, the next set down (S4, S5, and S6) corresponds to input channel 1, and so on. The bottom set of switches (S22, S23, and S24) corresponds to input channel 7. Refer to Figure 2 for the switch locations.
3. Loosen the strain-relief screws and remove the strain-relief bar.
4. Run the signal wires through the strain-relief opening. You can add insulation or padding if necessary.
5. Prepare the signal wire by stripping the insulation no more than 7 mm (0.28 in.).
6. Connect the wires to the screw terminals by fully inserting the stripped end of the wire into the terminal. No bare wire should extend past the screw terminal. Exposed wire increases the risk of shorting and causing a failure.
7. Tighten the screw terminal to a torque of 0.57 to 0.79 N · m (5–7 lb.-in.).

8. Connect the shield or earth ground to the earth-ground lug.
9. Reinstall the strain-relief bar and tighten the strain-relief screws.
10. Reinstall the top cover and tighten the top cover screws.
11. Connect the terminal block to the module front connector as explained in the *Installing the Terminal Block* section.

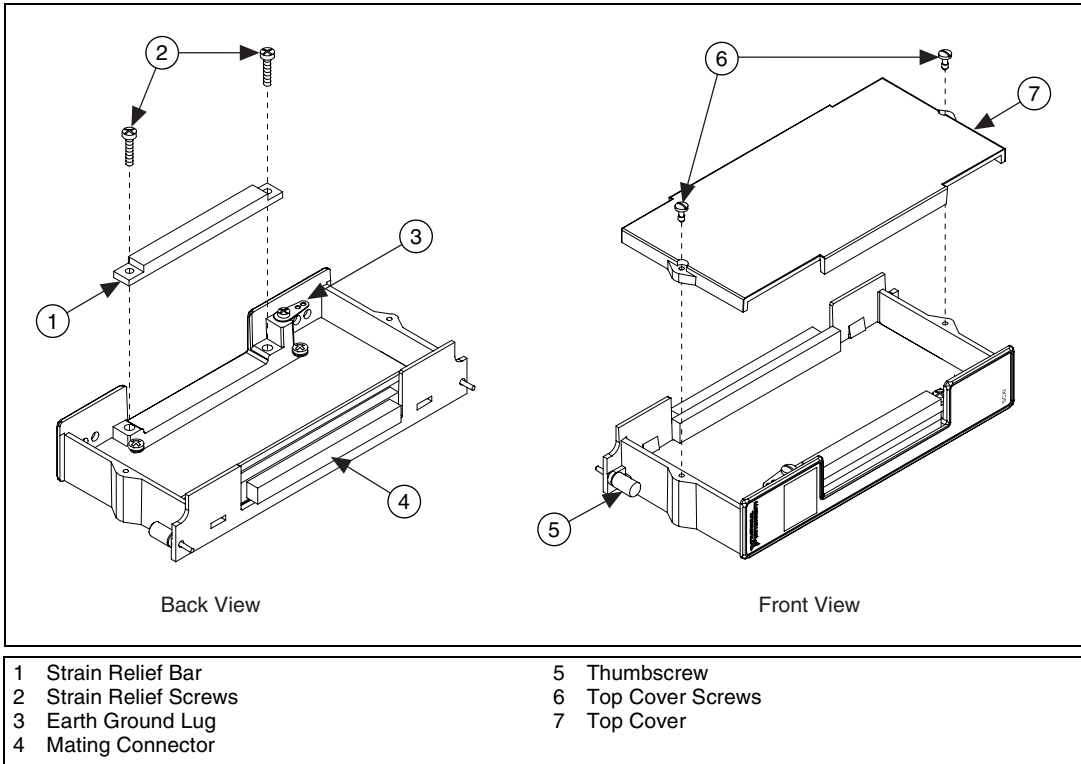
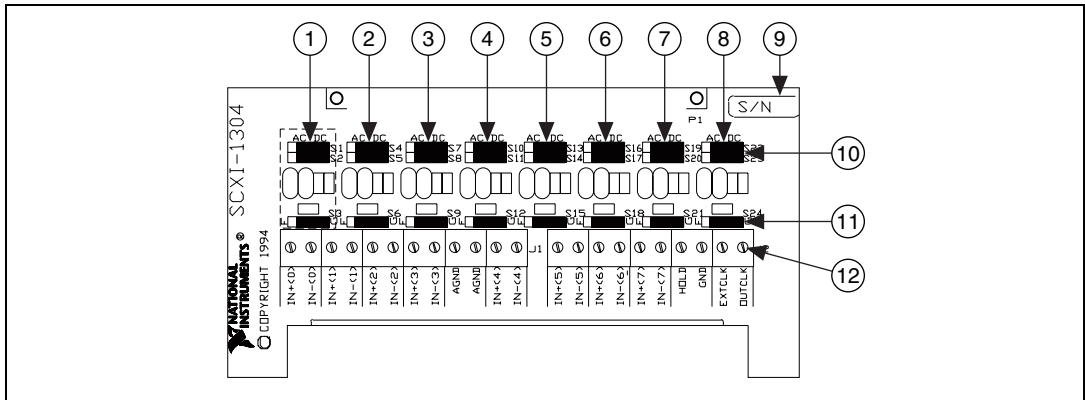

Figure 1. SCXI-1304 Parts Locator Diagram



1 Channel 0 Switches	5 Channel 4 Switches	9 Serial Number
2 Channel 1 Switches	6 Channel 5 Switches	10 Eight AC/DC Coupling Switches
3 Channel 2 Switches	7 Channel 6 Switches	11 Eight Floating/Ground-Reference Switches
4 Channel 3 Switches	8 Channel 7 Switches	12 Screw Terminals

Figure 2. SCXI-1304 Terminal Block Parts Locator Diagram

Installing the Terminal Block

To connect the terminal block to the SCXI module front connector, complete the following steps:

1. Connect the module front connector to its mating connector on the terminal block.
2. Tighten the top and bottom thumbscrews on the back of the terminal block to hold it securely in place.

Specifications

All specifications are typical at 25 °C unless otherwise specified.

Analog Input

Input coupling AC (1-pole highpass filter)
 -3 dB cutoff frequency 0.16 Hz¹

¹ The capacitors can block up to 50 VDC.

Maximum Working Voltage

Maximum working voltage refers to the signal voltage plus the common-mode voltage.

Channel-to-earth60 V, Installation Category I

Channel-to-channel.....60 V, Installation Category I



Note The maximum working voltage of non-isolated modules is found in the specifications of the module.

Environmental

Operating temperature0 to 50 °C

Storage temperature-20 to 70 °C

Humidity10 to 90% RH, noncondensing

Maximum altitude.....2,000 m

Pollution Degree (indoor use only)2

Safety

The SCXI-1304 is designed to meet the requirements of the following standards of safety for electrical equipment for measurement, control, and laboratory use:

- IEC 61010-1, EN 61010-1
- UL 3111-1, UL 61010B-1
- CAN/CSA C22.2 No. 1010.1



Note For UL and other safety certifications refer to the product label or to ni.com.

Electromagnetic Compatibility

EmissionsEN 55011 Class A at 10 meters.
FCC Part 15A above 1 GHz

ImmunityEN 61326:1997 + A21:2001,
Table 1

EMC/EMICE, C-Tick and FCC Part 15
(Class A) Compliant



Note For EMC compliance, operate this device with shielded cabling.

CE Compliance

The SCXI-1304 meets the essential requirements of applicable European Directives, as amended for CE Marking, as follows:

Low-Voltage Directive (safety) 73/23/EEC

Electromagnetic Compatibility
Directive (EMC) 89/336/EEC



Note Refer to the Declaration of Conformity (DoC) for this product for any additional regulatory compliance information. To obtain the DoC for this product, click **Declarations of Conformity Information** at ni.com/hardref.nsf/.

Circuit Diagram

You do not need to read this section to operate the SCXI-1304. The circuit diagram in Figure 3 is optional information that you can use if you want more details about the SCXI-1304 circuitry. Figure 3 shows the circuitry for one of the eight analog channels.

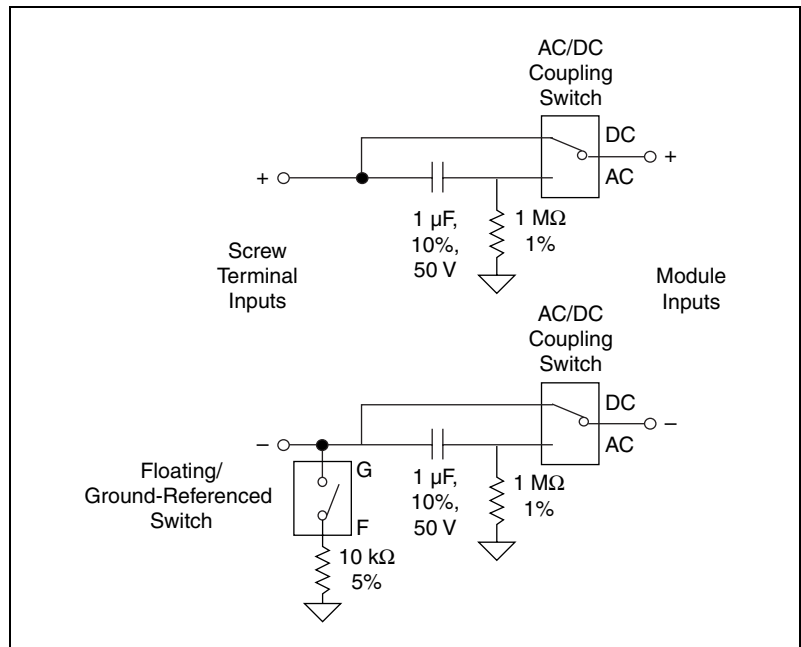

Figure 3. SCXI-1304 Circuit Diagram