

COMPREHENSIVE SERVICES

We offer competitive repair and calibration services, as well as easily accessible documentation and free downloadable resources.

SELL YOUR SURPLUS

We buy new, used, decommissioned, and surplus parts from every NI series. We work out the best solution to suit your individual needs.

 Sell For Cash  Get Credit  Receive a Trade-In Deal

OBSOLETE NI HARDWARE IN STOCK & READY TO SHIP

We stock **New**, **New Surplus**, **Refurbished**, and **Reconditioned** NI Hardware.



Bridging the gap between the manufacturer and your legacy test system.

 1-800-915-6216

 www.apexwaves.com

 sales@apexwaves.com

All trademarks, brands, and brand names are the property of their respective owners.

Request a Quote

 **CLICK HERE**

SH68-68-EP

INSTALLATION GUIDE

BNC-2110

BNC Adapter for E/M/S Series and Analog Output Series Devices

This installation guide describes how to install and configure your BNC-2110 accessory with 68-pin or 100-pin E/M/S Series or 68-pin NI 671x/672x/673x Analog Output (AO) Series multifunction data acquisition (DAQ) devices. This document also contains accessory specifications.

The BNC-2110 is ideal for simplifying connections between your measurement apparatus and your DAQ device in laboratory, test, and production environments. The BNC-2110 has the following features:



- 15 BNC connectors for analog input, analog output, trigger/counter functions, and user-defined signals
- A spring terminal block with 30 pins for digital and timing I/O signal connections
- A 68-pin I/O connector that connects to multifunction DAQ devices
- Can be used on a desktop or mounted on a DIN rail

Contents

Conventions	1
What You Need to Get Started	2
Installing the BNC-2110	3
Connecting Differential Analog Input Signals (E/M/S Series Devices Only).....	5
Measuring Floating Signals	5
Measuring Ground-Referenced Signals.....	5
Connecting Analog Output Signals	6
Connecting APFI 0/AO EXT REF Signals.....	6
Connecting Trigger/Counter Signals	7
Connecting Digital and Timing I/O Signals	7
Using the USER 1 and USER 2 BNC Connectors	9
Specifications.....	10

Conventions

The following conventions are used in this document:

- <> Angle brackets that contain numbers separated by an ellipsis represent a range of values associated with a bit or signal name—for example, AO <3..0>.
- » The » symbol leads you through nested menu items and dialog box options to a final action. The sequence **File»Page Setup»Options** directs you to pull down the **File** menu, select the **Page Setup** item, and select **Options** from the last dialog box.
-  This icon denotes a note, which alerts you to important information.
-  This icon denotes a caution, which advises you of precautions to take to avoid injury, data loss, or a system crash. When this symbol is marked on a product, refer to the *Read Me First: Safety and Radio-Frequency Interference* document for information about precautions to take.

bold	Bold text denotes items that you must select or click in the software, such as menu items and dialog box options. Bold text also denotes parameter names.
<i>italic</i>	Italic text denotes variables, emphasis, a cross-reference, or an introduction to a key concept. Italic text also denotes text that is a placeholder for a word or value that you must supply.
monospace	Text in this font denotes text or characters that you should enter from the keyboard, sections of code, programming examples, and syntax examples. This font is also used for the proper names of disk drives, paths, directories, programs, subprograms, subroutines, device names, functions, operations, variables, filenames, and extensions.
Platform	Text in this font denotes a specific platform and indicates that the text following it applies only to that platform.

What You Need to Get Started

To set up and use your BNC-2110 accessory, you need the following:

- BNC-2110 BNC adapter(s)¹
- BNC-2110 Installation Guide*
- One of the following DAQ devices:
 - 68-pin AO/E/M/S Series device (with one or two I/O connectors)²
 - 100-pin E Series device
- Cable(s) for DAQ device(s), as listed in Table 1
- The *Analog Output Series User Manual*, the *E Series User Manual*, the *M Series User Manual*, or the *S Series User Manual*
- BNC cables
- Small flathead screwdriver
- 28–16 AWG wire
- Wire strippers

¹ You can use two BNC-2110 accessories with both connectors of NI 6224/6229/6254/6259/6284/6289 M Series devices.

² On two-connector AO Series and NI 6225/6255 devices, you cannot use the device's second connector with the BNC-2110.

Installing the BNC-2110

Figure 2 shows the front panel of the BNC-2110.

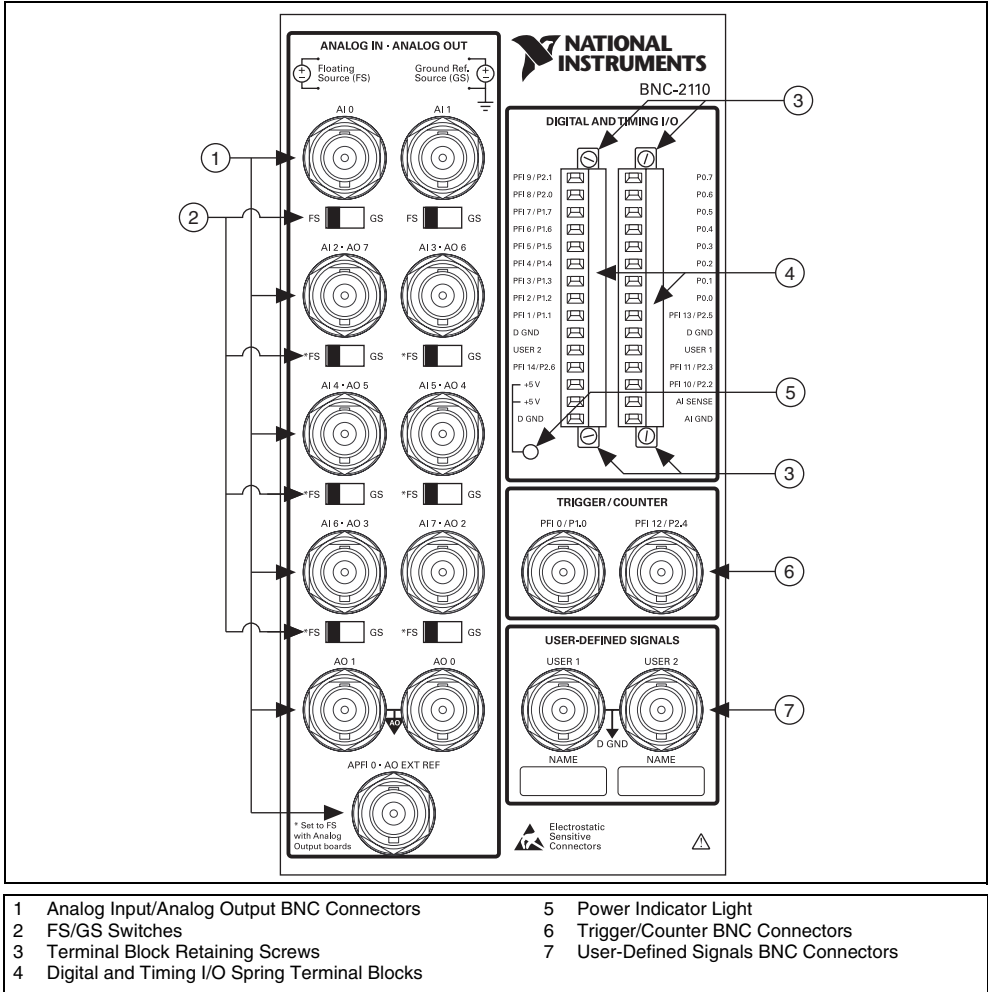

Figure 1. BNC-2110 Front Panel

To connect the BNC-2110 to your DAQ device, complete the following steps. Consult your computer or PXI/PXI Express chassis user manual for specific instructions and warnings.



Note If you have not already installed your DAQ device, refer to the *DAQ Getting Started Guide* for instructions.



Caution Do not connect the BNC-2110 to any device other than National Instruments AO/E/M/S Series multifunction DAQ devices. Doing so can damage the BNC-2110, the DAQ device, or the host computer. National Instruments is *not* liable for damage resulting from these connections.

1. Place the BNC-2110 near the host computer or PXI/PXI Express chassis or use the optional DIN Rail Mounting kit for UMI-FLEX-6 and BNC boxes (part number 777972-01), which you can order from National Instruments at ni.com.



Caution Do *not* connect input voltages greater than $42.4 V_{pk}/60$ VDC to the BNC-2110. The BNC-2110 is not designed for any input voltages greater than $42.4 V_{pk}/60$ VDC, even if a user-installed voltage divider reduces the voltage to within the input range of the DAQ device. Input voltages greater than $42.4 V_{pk}/60$ VDC can damage the BNC-2110, all devices connected to it, and the host computer. Overvoltage can also cause an electric shock hazard for the operator. National Instruments is *not* liable for damage or injury resulting from such misuse.

2. Connect the BNC-2110 to the DAQ device using the appropriate cable for your DAQ device, as listed in Table 1.

Table 1. BNC-2110 Cabling Options

Number of Pins	DAQ Device	Recommended Cable(s)
68-pin	NI 6715 AO Series DAQCard E Series NI PCI/PCIe/PXI/PXIe M Series* NI 6143 S Series	SHC68-68-EPM or RC68-68
	NI 672x AO Series†	SH68-C68-S
	NI 6711/673x AO Series PCI/PXI E Series USB Mass Termination M Series* NI 6110/6111/612x/613x S Series	SH68-68-EP or R6868
	NI 6713 AO Series NI 6115/6120 S Series	SH68-68-EP
100-pin	PCI/PXI E Series	SH1006868
* You cannot connect the BNC-2110 to Connector 1 of NI 6225/6255 devices.		
† You cannot connect the BNC-2110 to the AO 8–31 Connector of NI 6723 devices.		

The power indicator light, shown in Figure 1, lights. If it does not light, check the cable and wiring connections.

3. Launch Measurement & Automation Explorer (MAX), confirm that your DAQ device is recognized, and configure your device settings. Refer to the *DAQ Getting Started Guide* for more information.
4. Connect signals to the BNC connectors and spring terminal block as described in the following sections.



Note With NI-DAQmx, National Instruments has revised its terminal names so they are easier to understand and more consistent among NI hardware and software products. The revised terminal names used in this document are usually similar to the names they replace. For a complete list of Traditional NI-DAQ (Legacy) terminal names and their NI-DAQmx equivalents, refer to the *Terminal Name Equivalents* table in the *NI-DAQmx Help*.

5. Test specific device functionality, such as the ability to send and receive data with MAX test panels. Refer to the *DAQ Getting Started Guide* for more detailed information about running test panels in MAX.

When you have finished using the BNC-2110, power off any external signals connected to the BNC-2110 before you power off your computer.

Connecting Differential Analog Input Signals (E/M/S Series Devices Only)

Use the BNC-2110 BNC connectors on the front panel to connect AI <0..7> signals to E/M/S Series DAQ devices. The BNC-2110 is *only* intended for differential analog input signals. The number of connectors you use depends on your DAQ device and application. Complete the following steps to measure a differential (DIFF) analog input signal.

1. Connect the BNC cable to one of the AI <0..7> BNC connectors on the front panel.¹
2. Configure your software to measure this channel differentially.
3. Move the FS/GS switch to the applicable position, depending on whether you are measuring a floating source (FS) or ground-referenced source (GS) analog input signal. Refer to the *Measuring Floating Signals* and *Measuring Ground-Referenced Signals* sections for more information about these signal sources.

Measuring Floating Signals

To measure floating signal sources, move the corresponding switch below the BNC connector to the FS position. In the floating source switch position, the DAQ device's amplifier negative terminal connects to ground through a 5 k Ω resistor in parallel with a 0.1 μ F capacitor, as shown in Figure 2. Refer to your DAQ device documentation for more information about measuring floating signals.

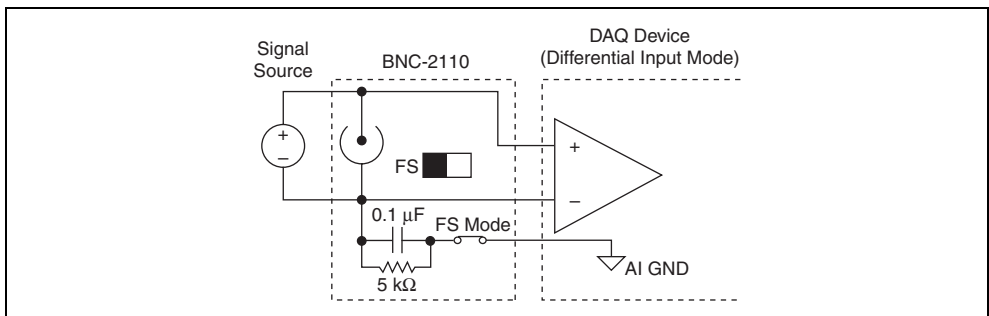

Figure 2. Measuring a Floating Signal Source

Measuring Ground-Referenced Signals

To measure ground-referenced signals, move the switch below the BNC connector for the AI channel you are using to the GS position. Using the ground-referenced source switch position avoids ground loops, as shown in Figure 3. Refer to your DAQ device documentation for more information about measuring ground-referenced signals.

¹ When using the BNC-2110 with Connector 1 of NI 6224/6229/6254/6259/6284/6289 devices, the AI <0..7> BNCs on the BNC-2110 map to the AI <16..23> channels on the M Series device.

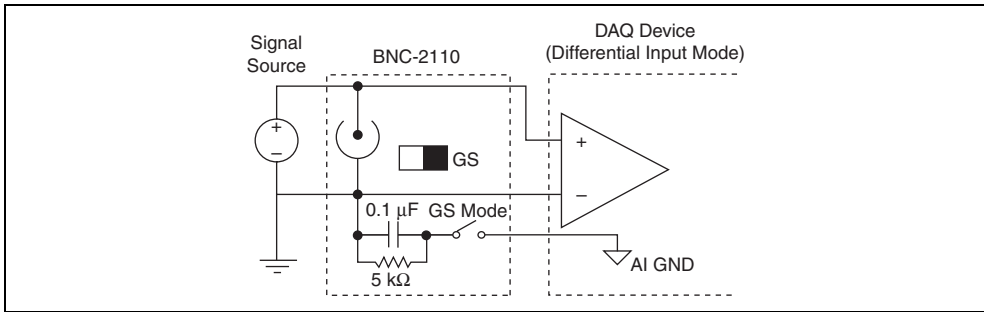

Figure 3. Measuring a Ground-Referenced Signal Source

Connecting Analog Output Signals

Use the BNC-2110 BNC connectors on the front panel to connect AO <0..7> signals to your DAQ device. The number of connectors you use depends on your DAQ device and application. E/M/S Series DAQ devices can only use the AO <0..1> BNCs.¹ AO Series DAQ devices can use the AO <0..1> and the AO <2..7> BNCs. Refer to your DAQ device documentation for information about the use of these signals.



Note (AO Series Devices Only) When using connectors AO <2..7>, you *must* move the associated FS/GS switch(es) to the FS position.

Connecting APFI 0/AO EXT REF Signals

Use the BNC-2110 BNC connectors on the front panel to connect the analog programmable function interface channel, APFI 0, to your M Series DAQ device or analog output external reference, AO EXT REF, to your AO/E/S Series device.² The AO EXT REF BNC is the external reference input for the AO circuitry. With some M Series devices, the APFI 0 channel can be used as the external reference input for the AO circuitry, the external offset for the AO circuitry, or the analog trigger input. These functions are not available on all devices. Whether you can use this BNC depends on your DAQ device and application. Refer to your DAQ device documentation for information about the use of these signals.

¹ When using the BNC-2110 with Connector 1 of NI 6229/6259/6289 devices, the AO <0..1> BNCs on the BNC-2110 map to the AO <2..3> channels on the M Series device.

² When using the BNC-2110 with Connector 1 of NI 6254/6259/6284/6289 devices, the APFI 0 BNC on the BNC-2110 maps to the APFI 1 channel on the M Series device.

Connecting Trigger/Counter Signals

Use the BNC-2110 BNC connectors on the front panel to connect PFI 0/P1.0 (AI START TRIG) and PFI 12/P2.4 (CTR 0 OUT) signals to your DAQ device. The number of connectors you use depends on your DAQ device and application. Refer to your DAQ device documentation for information about the use of these signals. Table 2 describes the trigger/counter BNCs.

Table 2. Trigger/Counter Signal Descriptions

BNC	Description
PFI 0/P1.0	Programmable Function Input channel 0 or Port 1 Digital Input/Output channel 0
	AI START TRIG (AI Start Trigger Signal)—As an output, this pin is the ai/StartTrigger signal. In post-trigger DAQ sequences, a low-to-high transition indicates the initiation of the acquisition sequence. In applications with pre-trigger samples, a low-to-high transition indicates the initiation of the pre-trigger samples.
PFI 12/P2.4	Programmable Function Input channel 12 or Port 2 Digital Input/Output channel 4
	CTR 0 OUT (Counter 0 Output Signal)—As an input, this pin can be used to route signals directly to the RTSI bus. As an output, this pin emits the Ctr0InternalOutput signal.

Connecting Digital and Timing I/O Signals

Use the BNC-2110 spring terminal block on the front panel to connect digital and timing I/O signals to your DAQ device. Refer to your DAQ device documentation for information about the use of these signals.

When connecting signals to the spring terminals, you can use 28–16 AWG wire with the insulation stripped to 0.28 in.

Table 3 describes the digital terminals on the front panel of the BNC-2110.

Table 3. Digital and Timing I/O Terminal Descriptions

Terminal	Description
PFI <1..7>/ P1.<1..7>	Programmable Function Input channels 1 through 7 or Port 1 Digital Input/Output channels 1 through 7
PFI <8..9>/ P2.<0..1>	Programmable Function Input channels 8 through 9 or Port 2 Digital Input/Output channels 0 through 1
PFI 10/P2.2	Programmable Function Input channel 10 or Port 2 Digital Input/Output channel 2
	EXT STROBE (External Strobe Signal)—You can toggle this output with software controls to latch signals or trigger events on external devices
PFI 11/P2.3*	Programmable Function Input channel 11 or Port 2 Digital Input/Output channel 3
	AI HOLD COMP (AI Hold Complete Event Signal)—When enabled, this signal pulses once for each A/D conversion in sampling mode. The low-to-high edge indicates when the input signal can be removed from the input or switched to another signal.
PFI 13/P2.5	Programmable Function Input channel 13 or Port 2 Digital Input/Output channel 5
	CTR 1 OUT (Counter 1 Output Signal)—As an input, this pin can be used to route signals directly to the RTSI bus. As an output, this pin emits the Ctr1InternalOutput signal.
PFI 14/P2.6	Programmable Function Input channel 14 or Port 2 Digital Input/Output channel 6
	FREQ OUT (Frequency Output)—This output is from the frequency generator
P0.<0..7>	Port 0 Digital Input/Output channels 0 through 7—You can individually configure each signal as an input or output. P0.6 and P0.7 can control the up/down signal of general-purpose Counters 0 and 1, respectively
D GND	Digital Ground—This terminal supplies the reference for the digital signals at the I/O connector as well as the +5 VDC supply
USER <1..2>	User-Defined 1 and 2—Internally routed to USER 1 or USER 2 BNC, this terminal provides a user-definable BNC terminal. Refer to the Using the USER 1 and USER 2 BNC Connectors section for more information about using these signals.
+5 V	+5 V Power Source—These terminals are fused on the DAQ device; the current available depends on the device to which it is connected. Refer to your DAQ device specifications for more information.
AI GND*	Analog Input Ground—The analog input voltages are referenced to this node
AI SENSE*†	Analog Input Sense—This terminal is the reference node for channels AI <0..15> in non-referenced single-ended (NRSE) configurations
* E/M/S Series devices only.	
† Single-ended mode is <i>not</i> recommended on the BNC-2110.	

Using the USER 1 and USER 2 BNC Connectors

The USER 1 and USER 2 BNC connectors allow you to use a BNC connector for a digital or timing I/O signal of your choice. The USER 1 and USER 2 BNC connectors are routed (internal to the BNC-2110) to the USER 1 and USER 2 spring terminals, as shown in Figure 4.

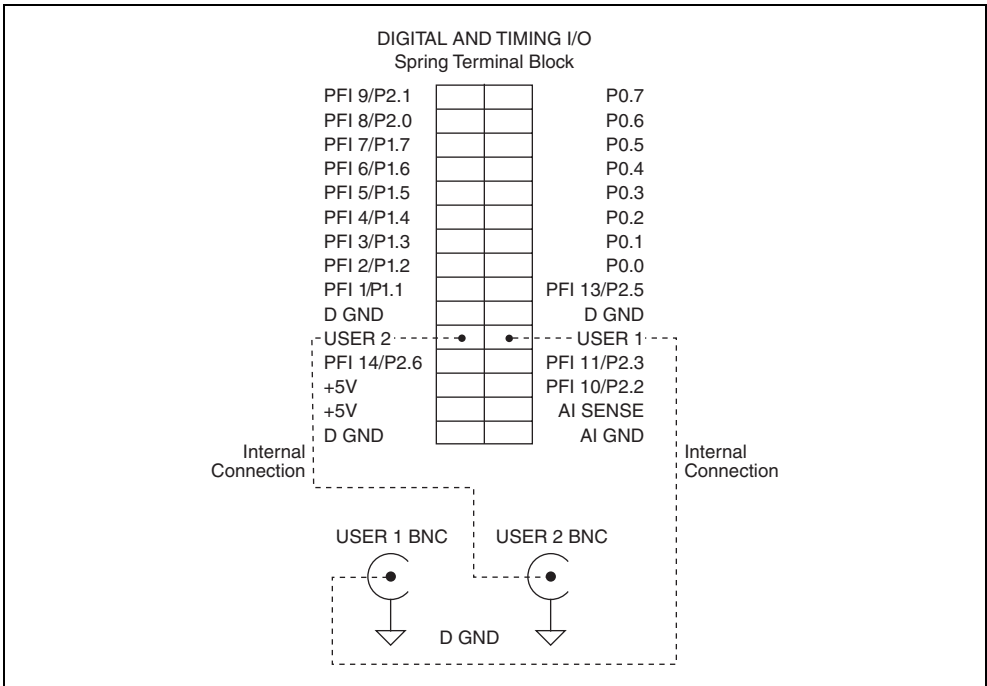

Figure 4. USER <1..2> BNC Connections

Figure 5 shows an example of how to use the USER 1 and USER 2 BNCs. To access the PFI 8 signal from a BNC, connect USER 2 on the spring terminal block to PFI 8/P2.0 with a wire.

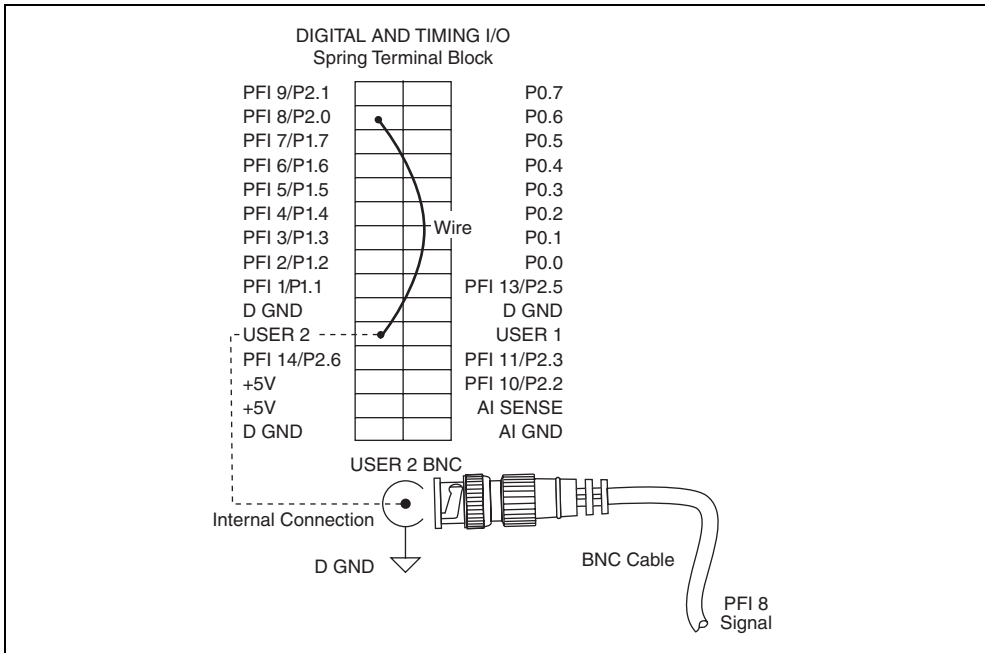

Figure 5. Connecting PFI 8 to USER 2 BNC

The designated space below each USER <1..2> BNC is for marking or labeling signal names.

Specifications

This section lists the specifications of the BNC-2110. These specifications are typical at 25 °C unless otherwise specified.



Note Refer to your DAQ device documentation for specifications about analog input, analog output, trigger/counter, and digital and timing I/O signals.

Physical

Dimensions	19.05 cm × 10.48 cm × 3.51 cm (7.5 in. × 4.125 in. × 1.38 in.)
Weight	798 g (1 lb 12.1 oz)
BNC connectors	15
Spring terminal block.....	30 positions
Wire gauge	28–16 AWG wire
I/O connector	68-pin SCSI male connector

Environment

Operating temperature	0 to 70 °C
Storage temperature	–55 to 125 °C
Relative humidity	5 to 90%, noncondensing

Pollution Degree (indoor use only).....	2
Maximum altitude.....	2,000 m

Safety

This product is designed to meet the requirements of the following standards of safety for electrical equipment for measurement, control, and laboratory use:

- IEC 61010-1, EN 61010-1
- UL 61010-1, CSA 61010-1



Note For UL and other safety certifications, refer to the product label or visit ni.com/certification, search by model number or product line, and click the appropriate link in the Certification column.

Electromagnetic Compatibility

This product is designed to meet the requirements of the following standards of EMC for electrical equipment for measurement, control, and laboratory use:

- EN 61326 EMC requirements; Minimum Immunity
- EN 55011 Emissions; Group 1, Class A
- CE, C-Tick, ICES, and FCC Part 15 Emissions; Class A



Note For EMC compliance, operate this device according to product documentation.

CE Compliance

This product meets the essential requirements of applicable European Directives, as amended for CE marking, as follows:

- 2006/95/EC; Low-Voltage Directive (safety)
- 2004/108/EC; Electromagnetic Compatibility Directive (EMC)



Note Refer to the Declaration of Conformity (DoC) for this product for any additional regulatory compliance information. To obtain the DoC for this product, visit ni.com/certification, search by model number or product line, and click the appropriate link in the Certification column.

Environmental Management

National Instruments is committed to designing and manufacturing products in an environmentally responsible manner. NI recognizes that eliminating certain hazardous substances from our products is beneficial not only to the environment but also to NI customers.

For additional environmental information, refer to the *NI and the Environment* Web page at ni.com/environment. This page contains the environmental regulations and directives with which NI complies, as well as other environmental information not included in this document.

Waste Electrical and Electronic Equipment (WEEE)



EU Customers At the end of their life cycle, all products *must* be sent to a WEEE recycling center. For more information about WEEE recycling centers and National Instruments WEEE initiatives, visit ni.com/environment/weee.htm.

电子信息产品污染控制管理办法（中国 RoHS）



中国客户 National Instruments 符合中国电子信息产品中限制使用某些有害物质指令 (RoHS)。关于 National Instruments 中国 RoHS 合规性信息, 请登录 ni.com/environment/rohs_china。(For information about China RoHS compliance, go to ni.com/environment/rohs_china.)

National Instruments, NI, ni.com, and LabVIEW are trademarks of National Instruments Corporation. Refer to the *Terms of Use* section on ni.com/legal for more information about National Instruments trademarks. Other product and company names mentioned herein are trademarks or trade names of their respective companies. For patents covering National Instruments products, refer to the appropriate location: **Help»Patents** in your software, the `patents.txt` file on your CD, or ni.com/patents.